

*HEWLETT*  *PACKARD*

**INSTRUMENTATION**

ELECTRONICS • MEDICINE • CHEMISTRY

**1967**



Instruments in this catalog are arranged by function and are preceded by technical information pages which summarize measuring techniques and provide information helpful for selecting instruments best suited for specific tasks.

Suggestions for communicating with Hewlett-Packard and for ordering is provided on the next page; information about Hewlett-Packard and available Services is on pages 1 through 14.

Gas Chromatographs; Preparative Gas Chromatographs; Carbon-Hydrogen-Nitrogen Analyzer; Microwave Spectrometer; Molecular Weight Determination; Osmometers, Auto-Viscometer

## Chemical Instrumentation

Diagnostic, Clinical Instruments; Patient Monitoring, intensive care; Patient Monitoring, operating room; Research Instruments; ECG Accessories

## Medical Instrumentation

Digital System Elements; Data Acquisition Systems; Digital Recorders; X-Y Recorders; Strip Chart Recorders; Oscillographic Recorders; Magnetic Tape Recorders

## Data Acquisition Systems and Recorders

Solid-State Devices; Working Standards; Voltage, Current, Resistance; Impedance; Coaxial, Waveguide; Communications Test Equipment; Signal Sources; Mixers, Modulators, Attenuators; Power; Noise Figure; Wave, Distortion, Spectrum Analyzers; Amplifiers; Oscilloscopes; DC Power Supplies; Electronic Counters; Frequency-Time Standards; Frequency Synthesizers; Nuclear; Temperature; Physical; Leak, Friction Detectors; Cabinets, Hardware

## Electronic Instrumentation and Components

Functional Index  
Model Number Index  
Sales and Service Office Index

## Indexes



## ABOUT HEWLETT-PACKARD



## HOW TO COMMUNICATE WITH HEWLETT-PACKARD

Hewlett-Packard products are manufactured in factories located throughout the free world. The Hewlett-Packard field sales office, representative, or distributor in your area is equipped to handle all your needs for information on any HP product, and for parts or service on HP products you are already using. A listing of field offices, representatives and distributors is at the back of this catalog. If none is listed for your area, please contact:

### United States of America

Hewlett-Packard  
1501 Page Mill Road  
Palo Alto, California 94304  
Telephone: (415) 326-7000  
TWX: 910-373-1267  
Telex: 34-8461

### Canada and Latin America

Hewlett-Packard  
Inter-Americas  
1501 Page Mill Road  
Palo Alto, California 94304, USA  
Telephone: (415) 326-7000  
Telex: 034-8461  
Cable: HEWPACK

### Europe

Hewlett-Packard S.A.  
54 Route des Acacias  
Geneva, Switzerland  
Telephone: (022) 42 81 50  
Telex: 2.24.86  
Cable: HEWPACKSA

### Africa, Asia, Australia

Hewlett-Packard  
Export Marketing  
1501 Page Mill Road  
Palo Alto, California 94304, USA  
Telephone: (415) 326-7000  
Telex: 034-8461  
Cable: HEWPACK

### Order by model number

When you order, please specify the catalog model number and name of instrument desired. For example, "Model 180A Oscilloscope." To prevent misunderstanding, include significant specifications. Whenever you want special options or features such as special color, non-standard power line voltage, etc., include specific instructions.

Many Hewlett-Packard instruments are supplied in cabinets along with easily attached hardware for direct mounting in 19" equipment racks. Other HP instruments are available in cabinets for bench use or with 19" panels (for example, "180AR") for rack mounting. Catalog listings indicate the availability of cabinet or rack mounting arrangements. Please be sure your order indicates which you desire.

### Price and delivery information

The illustrations and product information herein were current at the time this catalog was approved for printing. However, in order to continue to offer the finest instrumentation available, Hewlett-Packard Company reserves the right to change specifications, designs, models or prices without notice and without liability for such changes. Prices listed are F.O.B. USA factory or warehouse. Consult your nearest field sales office to confirm prices and to obtain current delivery information.

### Local technical assistance

Technical assistance in selecting equipment and preparing orders is available, without charge, from field engineers at sales offices in the USA and in principle areas throughout the world.

## FOR CUSTOMERS IN THE USA

### Where to send your order

Your order should be made out to the Hewlett-Packard Company and sent to the HP field office nearest you. Each field office has special communication channels to the Hewlett-Packard factories to assure prompt and efficient handling of your order.

### Shipping methods

Shipments to destinations in the USA are made directly from local factories or warehouses. Unless specifically requested otherwise, express or truck transportation is used, whichever is less expensive and most serviceable to you. Small items are sent parcel post. If rapid delivery is needed we will gladly ship by the more expensive methods of air freight, air express, or air parcel post when specified on your order. In many parts of the USA a consolidated air freight service provides the speed of air transport at surface rates. Ask your field engineer for details.

### Terms

Terms in the USA are 30 days net. Unless credit has already been established, shipments will be made C.O.D., or on receipt of cash in advance.

### Quotations

Upon request, quotations including destination prices, will be furnished to you by your local Hewlett-Packard sales office.

## FOR CUSTOMERS OUTSIDE THE USA

### Where to send your order

In many countries, your order can be placed directly on your local Hewlett-Packard distributor or representative (listed at the back of this catalog). If there is none, as yet, in your area, your order should be placed directly on one of the offices listed on this page.

### Shipping methods

Shipments to customers outside the USA or Western Europe are made from the appropriate Hewlett-Packard facility by either surface or air, as requested. Sea shipments usually require commercial export packaging at a nominal extra charge.

### Terms

Terms for orders from countries outside the United States of America which are placed on the Hewlett-Packard Company, Hewlett-Packard S.A., or Hewlett-Packard Inter-Americas, are irrevocable letter of credit or cash in advance, unless other terms have been arranged previously. Terms for orders placed on authorized Hewlett-Packard distributors are mutually determined between the customer and the distributor.

### Quotations and pro forma invoices

FAS, CIF, C&F, etc. quotations or pro forma invoices, as well as exportation and importation assistance, are available on request from local authorized Hewlett-Packard sales office or representative and from the offices listed on this page.

## MANUFACTURING OPERATIONS



## ABOUT HEWLETT-PACKARD

*"I often say that when you can measure what you are speaking about, and express it in numbers, you know something about it; but when you cannot measure it, when you cannot express it in numbers, your knowledge is of a meager and unsatisfactory kind . . ."*

Lord Kelvin (1824-1907)

Instruments for measurement are Hewlett-Packard's business. Electronic, chemical, and medical instrumentation products in the HP family now number more than 1500.

Since its founding in Palo Alto, California, in 1939, Hewlett-Packard has grown from a two-man operation into a world-wide organization of more than 11,000 people, with annual sales volume exceeding \$200,000,000.

The company and its affiliates now have more than a dozen manufacturing plants, including two in Western Europe and one in Japan. Sales and service offices are located in nearly every major city in the free world.

The original Hewlett-Packard products were electronic measuring instruments. With growth, the company's product family has expanded, and now it includes instruments for chemical and biomedical measurement and analysis. The development of new techniques for temperature measurement led Hewlett-Packard into the scientific instrument field; broadening involvement in that area is expected, through additional contributions. Hewlett-Packard believes that, in the future, the use of high-speed data handling and electronic computational techniques in instrumentation will lead it to more complex application opportunities for contribution in the instrument field.

The key to prospective involvement by Hewlett-Packard in any field of interest is *contribution*. Its philosophy of diversification and expansion is founded upon the concept of building on present strength.

At Corporate headquarters, in Palo Alto, California, are located the executive and administrative offices, and Hewlett-Packard Laboratories, the advanced research and development arm of the corporation.

### Hewlett-Packard manufacturing operations

Hewlett-Packard is organized into the product-centered divisions and affiliates listed below to assure concentrated effort in developing true state-of-the-art measuring tools, and to provide the specialized manufacturing experience and know-how that results in instrument quality and reliability.

#### Colorado Springs Division

Colorado Springs, Colorado — Oscilloscopes (dc through X-band, including storage), time domain reflectometers, pulse generators.

#### Delcon Division

Mountain View, California — Ultrasonic translator detectors for telephone and industrial applications, telephone speech scrambling equipment, buried cable fault locators, open fault locators.

#### Dymec Division

Palo Alto, California — Data acquisition instruments and systems, instrumentation computers, digital voltmeters, quartz thermometers, data amplifiers, signal-conditioning equipment.

#### F & M Scientific Division

Avondale, Pennsylvania — Gas chromatographs, accessories and services, osmometers, CHN analyzers.

#### Frequency and Time Division

Palo Alto, California — Electronic counters, quartz and atomic frequency standards, frequency synthesizers, digital printers, nuclear instrumentation.



Hewlett-Packard corporate headquarters, Palo Alto, California

## ABOUT HEWLETT-PACKARD



## MANUFACTURING OPERATIONS

### Harrison Division

Berkeley Heights, New Jersey — Regulated dc power supplies and related equipment.

### Hewlett-Packard G.m.b.H

Böblingen, West Germany — Audio analysis equipment and pulsers for world-wide distribution; also some of Hewlett-Packard's most widely used instruments for the European Common Market.

### Hewlett-Packard Ltd.

South Queensferry, Scotland — Communications test equipment for world-wide distribution; also Hewlett-Packard's more popular instruments for the British, EFTA, and Commonwealth markets.

### HP Associates (a subsidiary)

Palo Alto, California — Solid-state devices including hot-carrier, step-recovery and PIN diodes, microwave switches, optoelectronic detectors and sources.

### Loveland Division

Loveland, Colorado — Analog and digital voltmeters, oscillators and signal generators, ammeters, ohmmeters, working standards for voltage and resistance, distortion analyzers, communications test equipment.

### Microwave Division

Palo Alto, California — Microwave instruments, sweep and signal generators, signal sources, wave, phase and spec-

trum analyzers for microwave and high frequencies, analog instrumentation magnetic tape recorders.

### Moseley Division

Pasadena, California — X-Y plotters, laboratory and industrial potentiometric strip-chart recorders and accessories.

### Rockaway Division

Rockaway, New Jersey — Impedance and Q meters, inductance standards, high-frequency signal sources and signal generators, air navigation test sets.

### Sanborn Division

Waltham, Massachusetts — Medical and biophysical instrumentation, oscillographs, transducers, signal-conditioning equipment, instrumentation amplifiers.

### Yokogawa-Hewlett-Packard Ltd. (a joint venture)

Tokyo, Japan — Impedance measuring instruments, oscillators, power supplies for world-wide distribution; also more popular Hewlett-Packard instruments for the Japanese market.

### Applications assistance

Hewlett-Packard provides complete applications assistance and after-sale back-up through more than 170 sales and service offices situated around the world. Contact the office nearest you (listed at the back of this catalog) next time you have a measurement need.

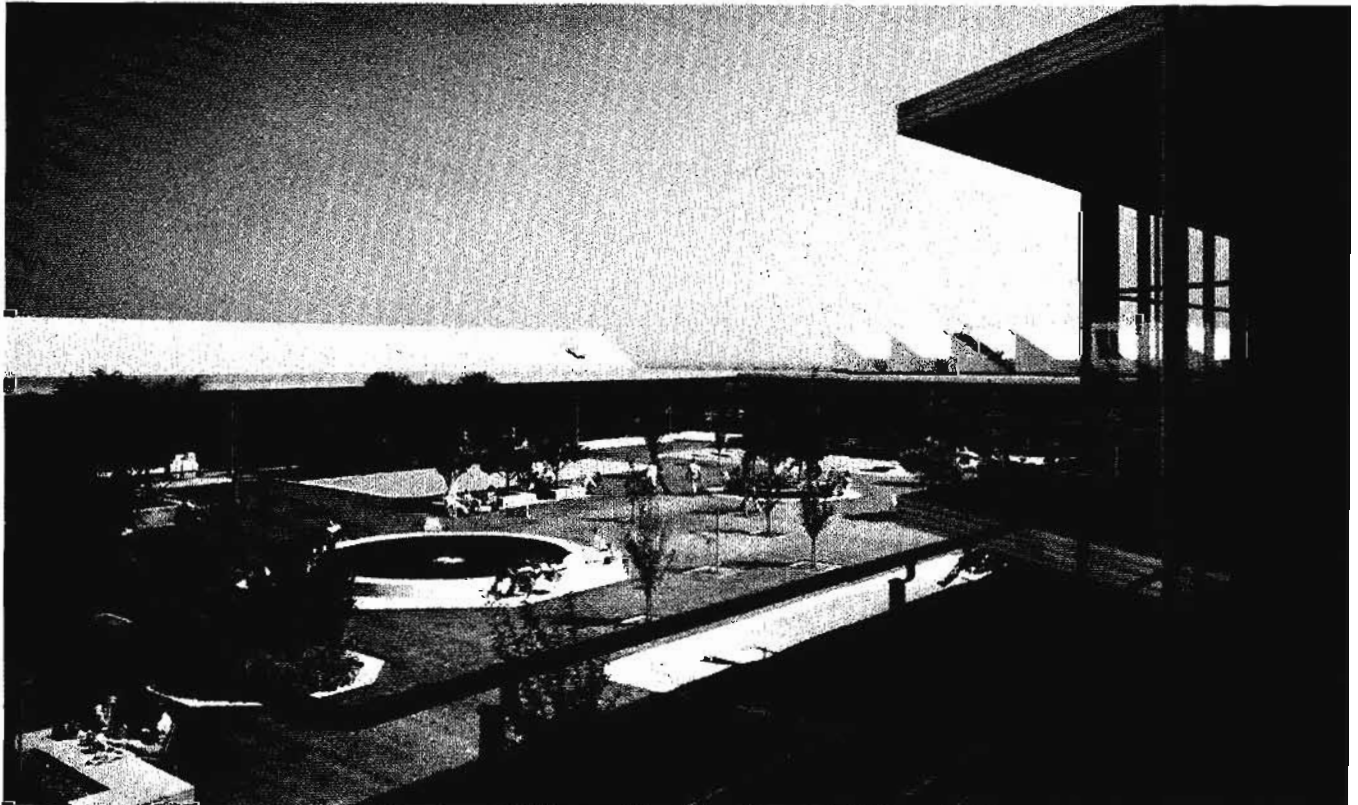

Hewlett-Packard has fifteen product-centered manufacturing operations.

## TOTAL SERVICE--PROVIDED WITH EVERY HEWLETT-PACKARD INSTRUMENT



## SERVICES

For nearly three decades, users of measuring instrumentation have found that they can rely on the integrity of Hewlett-Packard. This customer confidence has built Hewlett-Packard into one of the world's foremost manufacturers of electronic and scientific measuring instruments.

Companies making sophisticated measuring instruments have a special responsibility to their customers because of the highly critical ways in which instruments of this kind are often used. Whether the use is found in the maintenance of international communications, in the control laboratory of a petroleum refinery, or in a hospital operating room, it is essential that the equipment's performance meet its advertised specifications.

In recognition of this responsibility, Hewlett-Packard firmly adheres to the philosophy that its obligation to you as a customer does not end when your new instrument is delivered. In purchasing an HP measuring instrument, you are purchasing a way to do a job. You have the right to expect that your instrument will continue to do this job today, tomorrow, next week, and for a reasonable number of months and years in the future.

Hewlett-Packard implements this philosophy in two ways: (1) by initially making sure that it designs and builds for HP customers the finest, most reliable instruments possible, and (2) by backing up those instruments with a customer service program which can respond with speed and completeness to HP customers' needs.

This customer service program is one of the most important facets of Hewlett-Packard's worldwide operations. Directly involved in it at present are some 600 people located throughout the company.

... HP's customer service begins during the instrument design phase. Service engineers in each manufacturing division work closely with design and manufacturing engineers to assure that every instrument is as easily serviceable as possible.

... More than 100 HP field sales offices located in North America and abroad provide rapid and convenient service for Hewlett-Packard instruments. You need not correspond with a factory several thousand miles away for repair service, replacement parts, and technical assistance.

... Backing up these local offices are major service centers equipped with extensive replacement parts inventories and facilities for major overhauls and large calibration and repair operations. Presently serving HP's customers are two service centers in the U.S. and one in Europe, with more planned for the future.

Listed below are the elements of Hewlett-Packard's customer service program. The following pages briefly describe some of the benefits available to you as an HP customer under each of these headings:

- THE HEWLETT-PACKARD WARRANTY
- PRE-SALE PRODUCT INFORMATION
- TECHNICAL PUBLICATIONS
- TECHNICAL TRAINING PROGRAMS
- REPLACEMENT PARTS
- REPAIR SERVICE
- CUSTOMER SERVICE AGREEMENTS
- RECALIBRATION AND STANDARDS CALIBRATION

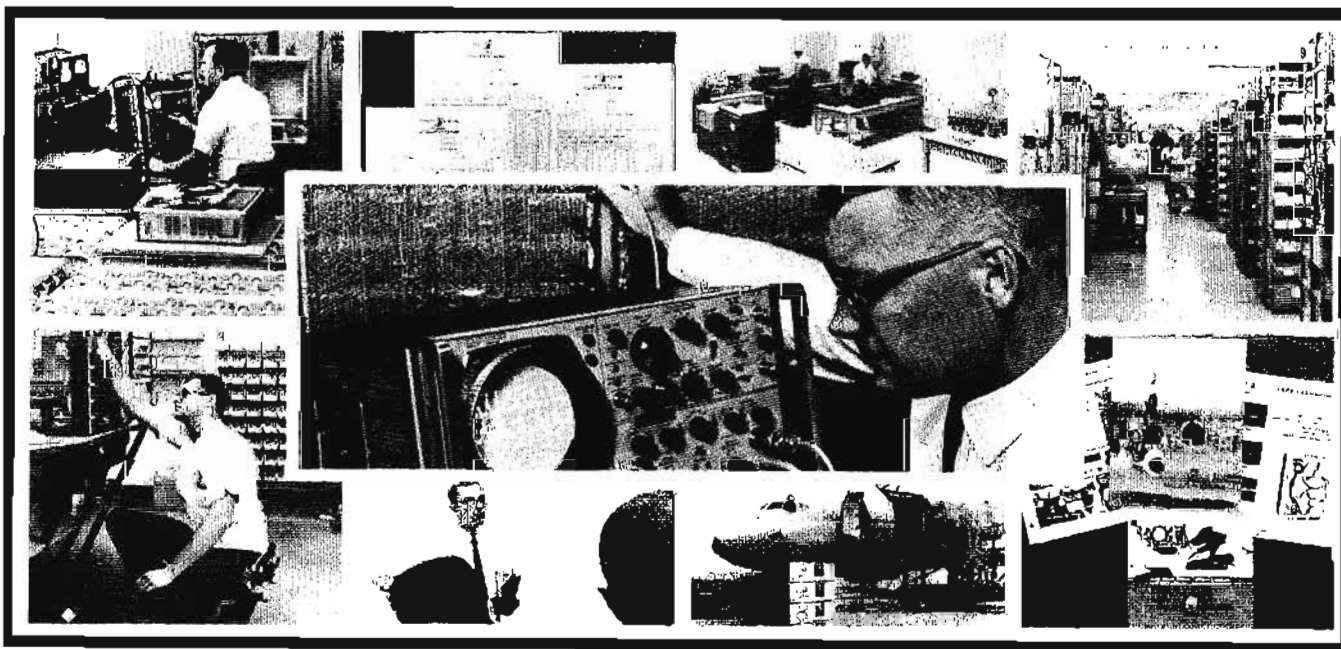

Hewlett-Packard gears its entire operation to one goal—the satisfied customer.

## SERVICES



## THE HEWLETT-PACKARD WARRANTY

When you buy a Hewlett-Packard instrument, you can count on receiving an instrument built with quality materials and workmanship. You can be sure that this instrument will perform as reliably and consistently as possible for a sophisticated piece of equipment.

The Hewlett-Packard warranty is an expression of confidence in the ability of HP instruments to measure up to this standard of performance.

The following warranty is the heart of an important and enduring Hewlett-Packard aim—to satisfy you initially and to keep you satisfied. It guarantees you an instrument which will perform the way you expect it to perform. It is backed by nearly 30 years of experience in the manufacture of precision measuring instruments:

### Certification

*Hewlett-Packard certifies that this instrument was thoroughly tested and inspected and found to meet its published specifications when it was shipped from the factory. Hewlett-Packard further certifies that its calibration measurements are traceable to the U.S. National Bureau of Standards to the extent allowed by the Bureau's calibration facility.*

### Warranty

*All Hewlett-Packard products are warranted against defects in materials and workmanship. This warranty applies for one year from the date of delivery, or, in the case of certain major components listed in the operating manual, for the specified period. We will repair or replace products which prove to be defective during the warranty period. No other warranty is expressed or implied. We are not liable for consequential damages.*



Ease of service is an important consideration during the various instrument design stages.



Production lines are designed to provide optimum worker accuracy and efficiency.



Every instrument manufactured is subjected to a thorough mechanical test.



A complete electrical test is also made to ensure that each instrument meets its published specifications.



Modern packing procedures minimize damage in transit.

## PRE-SALE PRODUCT INFORMATION



## SERVICES

To help you as a prospective buyer of measuring instrumentation make the best possible purchasing decision, Hewlett-Packard devotes a considerable amount of attention to making available accurate and complete product information.

### Technical Data Sheets

When you need information about a specific Hewlett-Packard instrument or system, HP's technical data sheets are a convenient and informative source of detailed data and specifications. These data sheets are well-written and amply illustrated with photographs, diagrams, and charts.

### A Highly Qualified Field Sales Force

Hewlett-Packard is proud of the members of its sales organization located throughout the world. These men are carefully selected and well trained in the capabilities of HP products and the needs of instrumentation users. You can rely on your local HP field instrumentation specialist for sound technical information and for accurate, concise answers to your questions.

### Staff Engineers

When you need technical assistance in a hurry, the quickest, most efficient source of information is your field sales office staff engineer. He's as near as your telephone — always available and ready to answer your call.

As the in-office counterpart of your HP field specialist, the HP staff engineer works together with him in providing you with the finest possible technical assistance. If you need applications information or technical data on HP products, be sure to give your local staff engineer a call.

### Demonstration Instruments

To make it possible for you to get a close look at the capabilities of Hewlett-Packard instruments, HP demonstration vans travel around the U. S. and other parts of the world making frequent demonstration stops. These vans offer you a chance to see and evaluate HP instruments in working displays.

### Special Instrument Modifications

With Hewlett-Packard's broad product base, standard instruments may often be modified to meet a wide variety of special applications. HP's divisionalization of product groups permits flexibility in manufacturing methods, and provides almost unlimited potential for special modifications. If you have a unique application and cannot find a standard instrument to do the job, check with your local HP field specialist. He is always ready to help you solve your measurement problems.

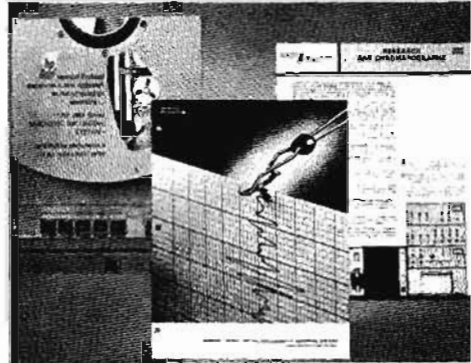





Sophisticated measuring instruments are very often rather intricate pieces of hardware. To take full advantage of the capabilities of these instruments, users generally have to familiarize themselves with a considerable amount of highly technical information. The primary source of this information for a particular instrument is the written material supplied by the manufacturer of that instrument.

Recognizing this responsibility, Hewlett-Packard devotes unusual attention to developing and distributing to its customers the most informative, readable, and generally useful written material of any manufacturer of measuring instrumentation.

### Operating and Service Manuals

The most important publication of all to a customer is the Operating and Service Manual for his instrument.

Hewlett-Packard's Operating and Service Manuals are outstanding technical publications—logically organized, well written, containing ample photographs, diagrams, and illustrations, and compatible with several publications standards. Included in each manual are sections covering the theory of operation, operating instructions, maintenance and calibration information, and a table of replacement parts.

A manual is supplied with each new instrument. As a further service, extra manuals for all current Hewlett-Packard instruments, as well as for many older instruments, are also available at reasonable cost.

### Service Notes

This series of technical publications is intended primarily as a vehicle for disseminating repair and maintenance information on Hewlett-Packard instruments. Acting as a convenient means of updating customers' Operating and Service Manuals, Service Notes cover such topics as new or special calibration techniques, instrument modifications, and special repair procedures—all written in a detailed manner. Ask your local field specialist for a copy of the Service Note Index so you can order those Service Notes of interest to you.

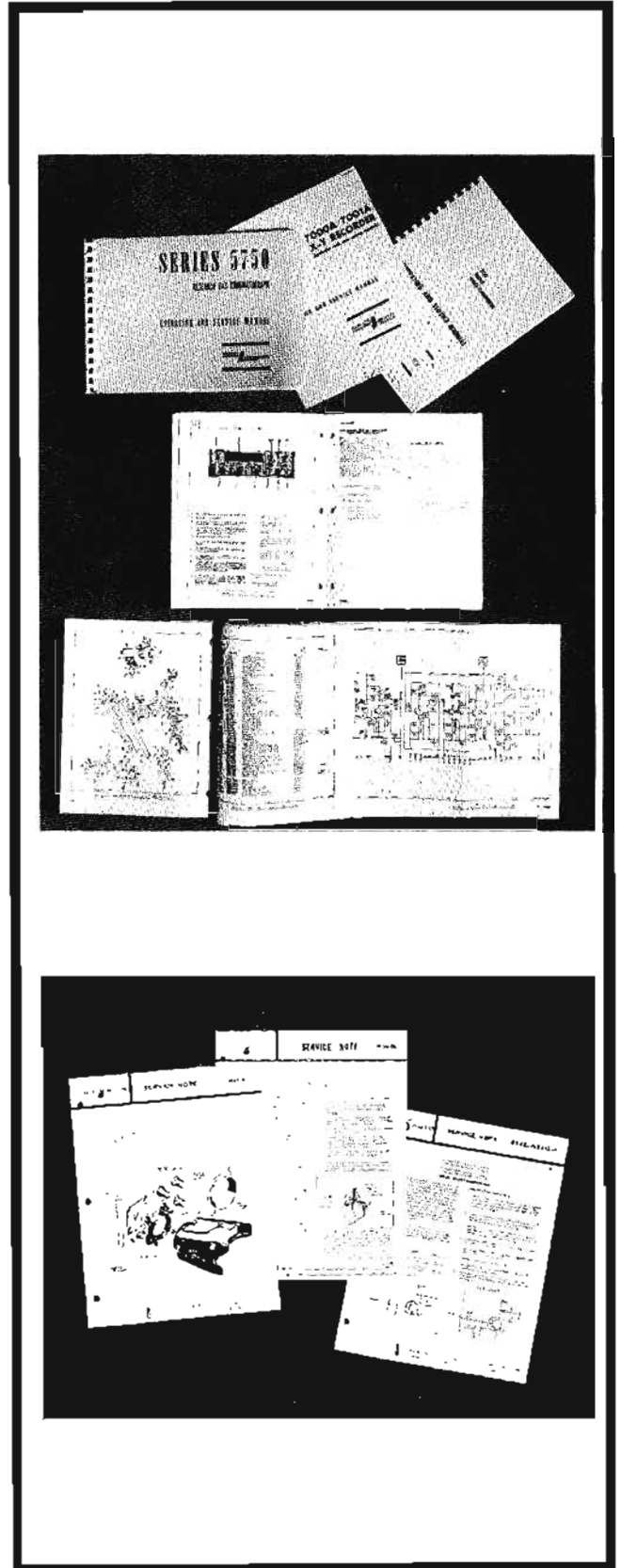

## TECHNICAL PUBLICATIONS



## SERVICES

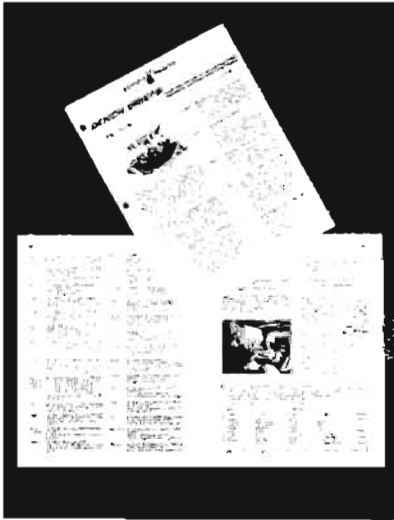

### Bench Briefs

This newsletter briefly describes new Service Notes and other service publications as they become available. Servicing tips and suggestions which may be helpful to you are also included. Your local Hewlett-Packard field sales office will be happy to place your name on the regular Bench Briefs mailing list.



### Application Publications

Hewlett-Packard application publications generally deal with individual measurement problems and offer suggestions and guidelines for developing analytical systems to meet these problems. Hewlett-Packard's two main application publications are Application Notes, primarily directed at the electronic discipline, and Applications Lab Report, intended mainly for chemical instrumentation users.

Because of their specialized nature, Hewlett-Packard's application publications are distributed by individual request. Your local field sales office will be glad to provide a list of application publications available.



### Measurement News

Announcements of new electronic instruments and articles of local interest are brought to you by your local field office in this bi-monthly publication. Also included are descriptions of new application publications as they become available. Ask your HP field sales office to place you on the regular mailing list.



**SERVICES**

**TECHNICAL PERIODICALS  
FROM HEWLETT-PACKARD**

### The Hewlett-Packard Journal

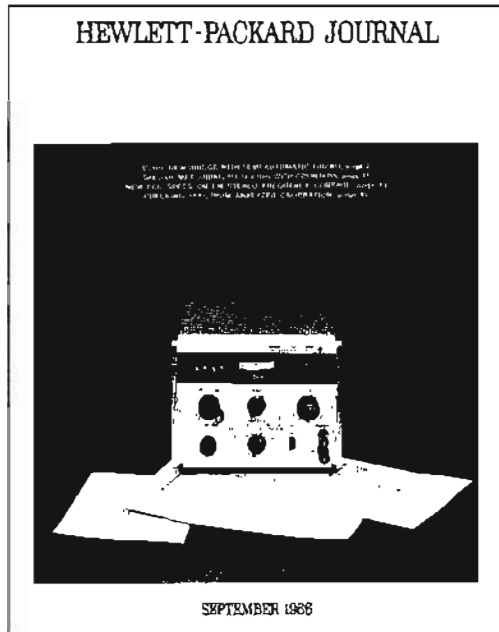

The *Hewlett-Packard Journal* is recognized as one of the most widely read engineering magazines in the electronics field. A monthly publication, the *Journal* contains authoritative articles by HP electronics engineers and scientists on the subjects of new instrumentation, measuring techniques, and related topics.

To be added to the circulation records, contact any HP field office or write: Editor, *Hewlett-Packard Journal*, 1501 Page Mill Road, Palo Alto, California, 94304.

### Facts and Methods for Scientific Research



**Facts and Methods for Scientific Research**—published bi-monthly by the HP Chemical Applications Laboratory—is devoted to reporting the results of applications work and new technological developments in the field of chemical instrumentation.

To receive future issues of *Facts and Methods*, send your name and address to any HP field sales office or 1501 Page Mill Rd., Palo Alto, California 94304.

### Measuring for Medicine and the Life Sciences



**Measuring for Medicine and the Life Sciences**, a quarterly publication from Hewlett-Packard's Sanborn Division, demonstrates by reports of actual applications how Sanborn and other HP instrumentation helps medicine and the life sciences obtain information on living processes—accurately, rapidly, and in the most meaningful form.

If you are interested in receiving *Measuring for Medicine*, contact your HP field sales office or 1501 Page Mill Rd., Palo Alto, California 94304.

## TECHNICAL TRAINING PROGRAMS



## SERVICES

To help assure that Hewlett-Packard customers are satisfied customers, HP makes available an extensive schedule of training courses, or training "seminars", that are designed to help users of measuring instruments maximize the efficiency of their equipment.

### Seminar Content

The seminars available to you from HP can be classified in two types. The first has to do with *using* equipment effectively. Subject matter generally includes the theory and application of a particular measuring technique, and the approach that HP has followed in developing an instrument to make use of this technique. This type of training session is called an "Applications Seminar".

The second type of seminar has to do with ways and means of *maintaining* equipment—in terms of both repair and calibration. This program is intended primarily for service technicians, and is called a "Service Seminar". By taking advantage of it, you can have factory trained technicians in your own facility.

### Training Locations

Both of these seminars are available to you in two locations—at HP field sales offices and at HP manufacturing

plants. Seminars conducted in field sales offices generally cover a given product area, such as oscilloscopes, nuclear instruments, gas chromatographs, etc., and last for 1-3 days.

Seminars conducted at manufacturing plants offer broader and deeper product coverage and generally last for one or two weeks. Portions of this training are tailored to individual needs where possible. Practical user experience in operation, repair, and calibration is emphasized.

### Seminar Arrangements

All sessions are conducted by technically competent instructors who are experienced in instructional techniques.

Your local HP field sales office will be glad to provide you with the schedule of seminars coming up in future months. In the case of field seminars (both applications and service), scheduling depends largely on the preferences expressed by customers. So if you would like to see a particular seminar offered in your area, be sure to mention it to your local field sales office.

Of course, there is no charge for any Hewlett-Packard training seminar. Your only cost is for your own transportation, lodging, and meals. If you wish, HP will be happy to help you arrange for lodging.

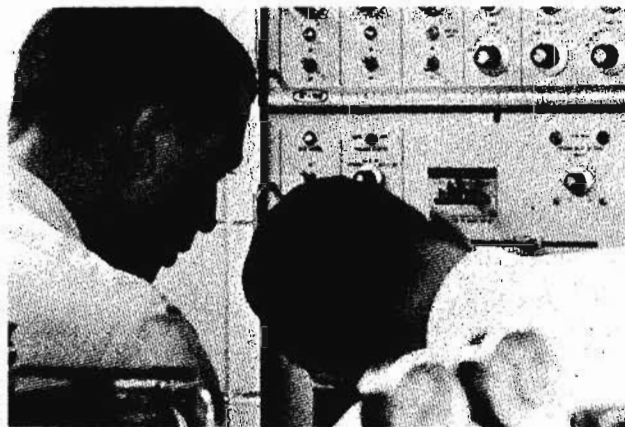

## SERVICES



## REPLACEMENT PARTS

### Inventories

Prompt instrument maintenance, done either in your facility or by Hewlett-Packard, depends on the immediate availability of replacement parts. For this reason, HP maintains extensive parts inventories at its field sales offices in many locations. These field sales offices are backed up by service centers, which maintain full factory level inventories, including many parts for older HP instruments.

### Parts Identification

As mentioned earlier, every HP instrument manual has a "Table of Replacement Parts" to make it easy for you to identify parts you wish to replace.

If you need further help in identifying replacement parts, be sure to call your Hewlett-Packard field sales office. Each office maintains extensive technical files to help identify parts rapidly, and further support is given each office by the service centers, which have complete microfiles including many of the older products. This capability provides complete information in a matter of seconds.

### Delivery Time

When it comes to replacement parts, customers have a right to expect product quality and fair value from their supplier. From Hewlett-Packard, this is exactly what they receive. Customers also have a right to expect fast delivery. With its extensive distribution of field sales offices and convenient local inventories, HP is uniquely qualified to provide fast delivery.

Normally, a replacement part order received by a USA field sales office will be filled and shipped the same day. Even if the office does not have the part in stock, this speed is not lost thanks to a computerized dataphone communications system linking each field office and service center.

In the USA if a field sales office receives an order for a part which it cannot supply, the order will be instantly relayed to a service center via the dataphone link. The order is then filled and shipped directly to the customer by the service center.

Hewlett-Packard can in this way offer unusual speed in the delivery of replacement parts.

**AT LEAST 90% OF THE ORDERS FOR REPLACEMENT PARTS RECEIVED BY AN HP FIELD SALES OFFICE WILL BE SHIPPED THE SAME DAY — EITHER FROM THE SALES OFFICE ITSELF OR FROM A SERVICE CENTER.**

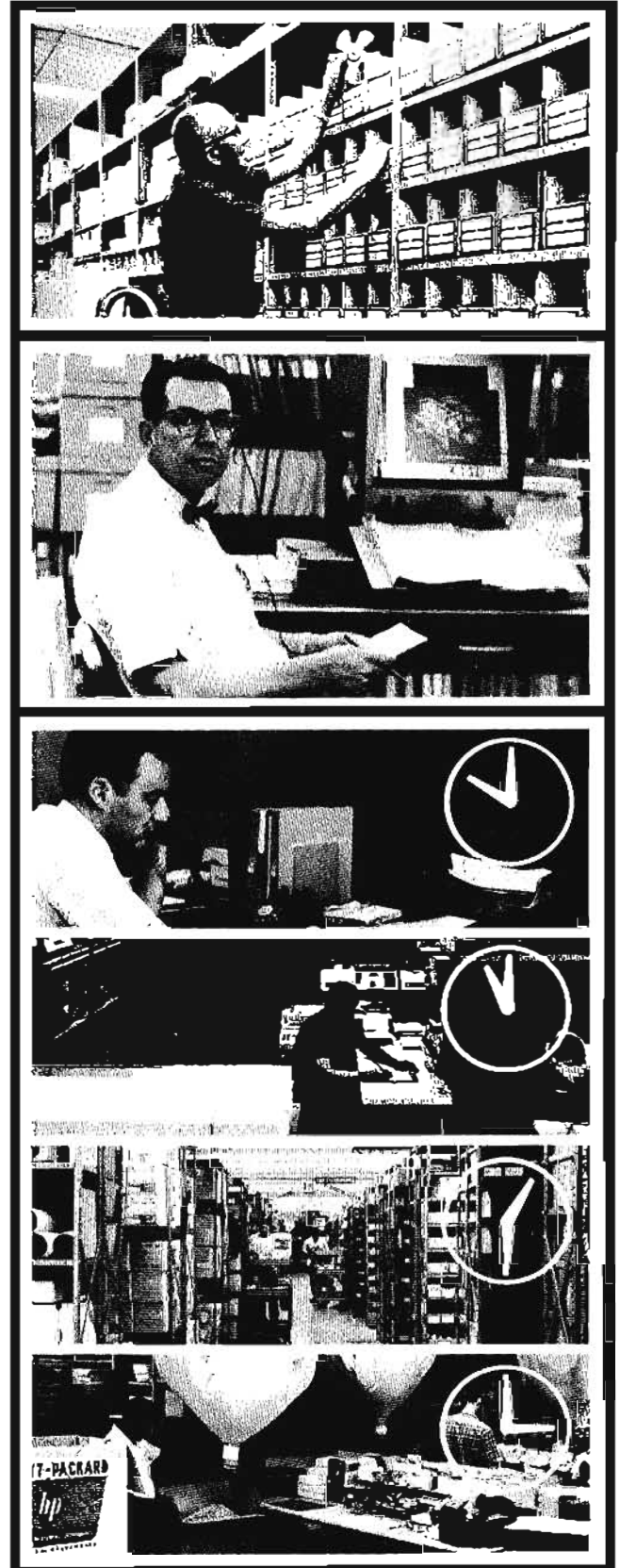

## REPLACEMENT PARTS



## SERVICES

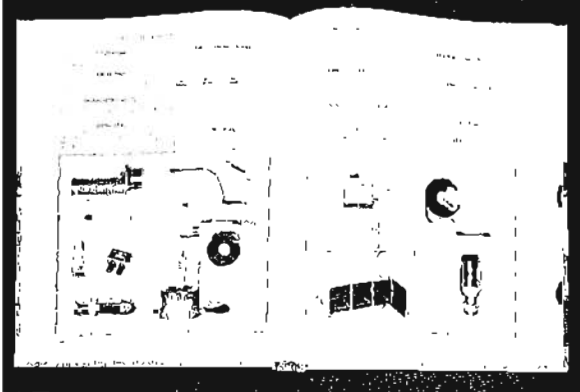

A wide variety of instrument accessories are always available for Hewlett-Packard Products.

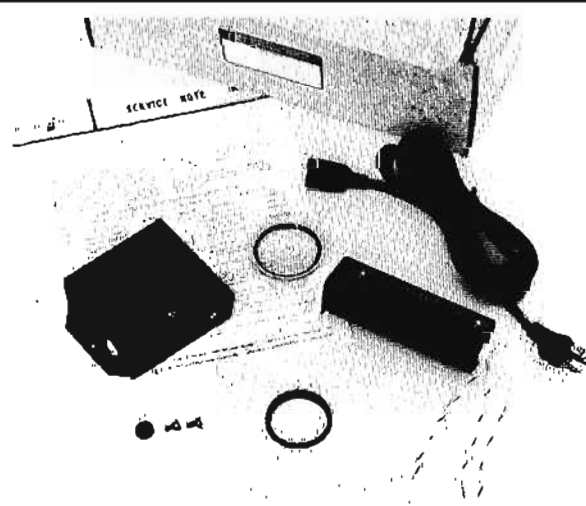

Shown here is the modification kit for the internal light source of the model 196A oscilloscope camera.



These items make up a spare parts kit for the model 417A VHF detector.

### Other Supplies

In addition to the usual replacement parts, *Accessories and Operating Supplies* are also in stock ready for immediate delivery.

*Modification Kits* may also be ordered from your nearby field sales office. Two publications from HP Customer Service, "Service Notes" and "Bench Briefs" (referred to earlier under TECHNICAL PUBLICATIONS), keep you abreast of modifications which are available.

Several types of *Spare Parts Kits* are available to sustain continuous operation from your HP instruments when they are being used in an isolated area, or where loss of the instrument's use would be extremely critical. "Running Spares" and "Isolated Service Kits" offer varying degrees of completeness, and you can choose the kit that most nearly satisfies your requirements.

### Ordering Procedure

When ordering a replacement part or supply item, please specify: (1) the HP stock number for the part, and (2) its complete name as indicated in the "Table of Replacement Parts" in your Operating and Service Manual. Since the characteristics of a given component may have been altered in subsequent production changes, you should be sure to take this information from the Operating and Service Manual you originally received with the instrument.

As indicated above, your local field sales office can also provide help in parts identification. If you do place an order for a part without a stock number, please include the instrument model number, its serial number, a complete description of the part, its function, and its location within the instrument.

## SERVICES



## REPAIR SERVICE

Hewlett-Packard is always prepared to back its products with the best possible repair service at a fair price.

To this end, most HP field sales offices throughout the world have repair and maintenance groups. These offices are backed by service centers which have complete maintenance facilities, sophisticated test equipment, factory trained specialists, and a full line of replacement parts. You are thus able to deal with one local HP sales office for all your instrumentation needs.

Service is always provided at a price which reflects a fair value for the work actually done and is consistent with what

customers reasonably expect to pay for the benefits received. In addition to needed repairs, HP performs calibration, preventive maintenance, and both mechanical and electrical inspection to ensure satisfactory operation and a prolonged life for your HP instruments.

HP also offers extensive overhaul services for older instruments. These models can often be rebuilt to meet the specifications of the current production models. If a model is no longer manufactured, an overhaul will restore the instrument to its original usefulness.

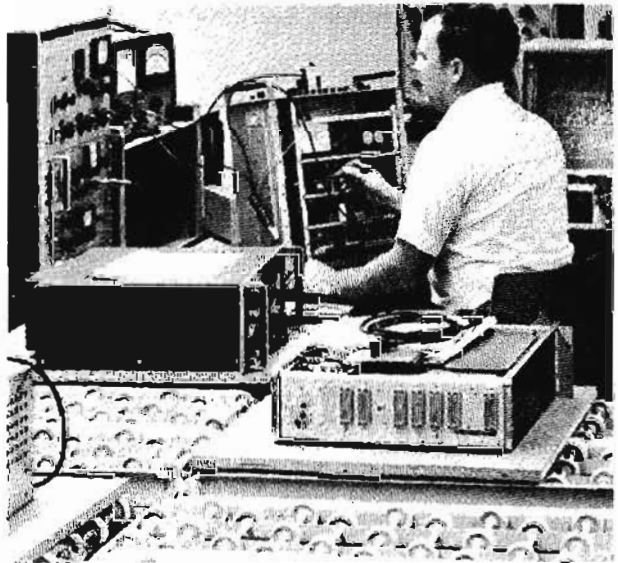
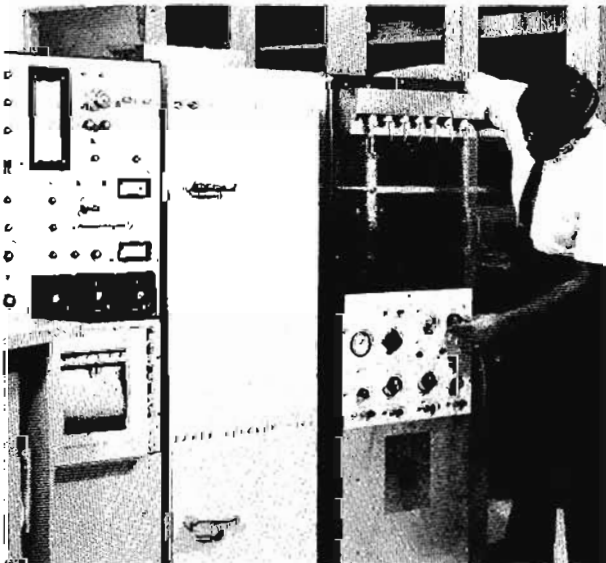
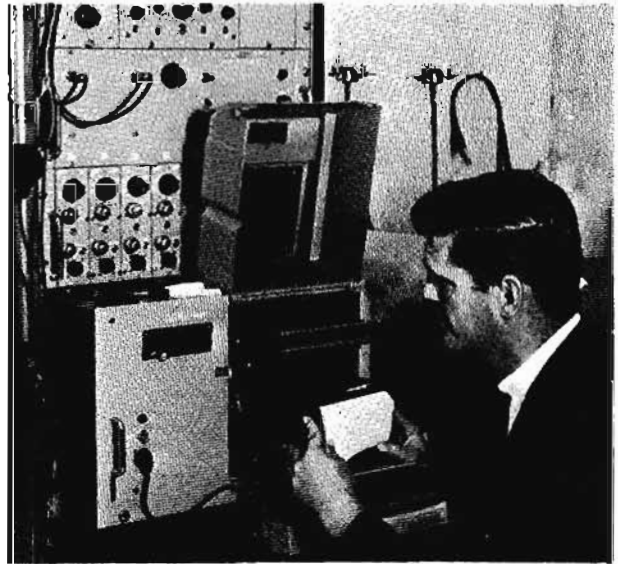
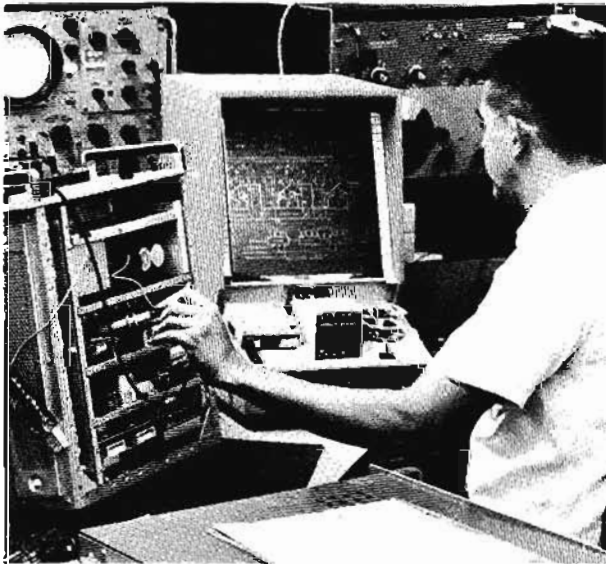

# CUSTOMER SERVICE AGREEMENTS



# SERVICES

Many Hewlett-Packard customers have found that they can eliminate guesswork from their instrument maintenance program and save money at the same time by joining HP in a Customer Service Agreement.

This is a well defined service program that can reduce your costs by making sure that your instruments are operating properly, by minimizing instrument downtime, and by extending the useful life of your instruments. For a basic annual cost agreed upon by you and Hewlett-Packard, you can let HP assume your maintenance responsibilities and, in so doing, reduce your own resources tied up in maintenance.

Three types of Customer Service Agreements are available. The first is an *instrument* maintenance agreement, with either on-site or in-shop service available. The second is a *systems* service program, with the work usually done at your location. The third is a *resident* service agreement, in which a factory-trained HP service specialist is stationed at your location to handle maintenance for your HP equipment.

The services available include (1) calibration and preventive maintenance, (2) emergency repair service, (3) free parts replacement (except for parts valued at more than \$100, and except in the case of resident agreements), and (4) additional features as follows... your choice of either in-shop (in HP facilities) or on-site (at your location) service... pick-up and delivery for in-shop service... the addition of new HP instruments to the contract at no charge... a discount of 10% for new systems installations... standards lab capabilities for special requirements.

Hewlett-Packard's Customer Service Agreement program is based on the extensive histories of service and repair information which have been collected on each HP instrument. By taking advantage of this information in the context of an HP Customer Service Agreement, you can improve the usefulness and efficiency of each of your instruments, and do it at a fair price.

Contact your HP field sales office for more information.

The collage consists of 12 individual photographs, each with a caption below it:

- Maximum equipment use:** A technician in a white lab coat works on a piece of HP equipment.
- Minimized downtime:** A technician is shown working on a complex piece of electronic equipment.
- Trained repair specialists:** A technician is focused on repairing a device.
- Known annual cost:** Two men in suits are seated at a desk, reviewing documents.
- New instruments added free:** A close-up of a technician's hands adjusting a control knob on a device.
- On-site service:** A technician is performing maintenance on a piece of equipment in a field setting.
- 10% discount on systems:** A technician is working on a large rack-mounted system.
- Day and night service:** A technician is working in a dark environment, possibly a control room or lab.
- Defective parts replaced free:** A technician is handling a component in a parts bin.
- Standards lab calibration:** A technician is working on a piece of equipment in a laboratory setting.



## SERVICES



## RECALIBRATION AND STANDARDS CALIBRATION

To insure that an electronic instrument continues to perform reliably, its operation should be routinely verified from time to time. Each Hewlett-Packard operating and Service Manual provides the information you need to recalibrate instruments in your own facility. If you prefer, the local HP sales office will be happy to arrange your recalibration for you.

In addition to this normal recalibration service, Hewlett-Packard also offers a standards calibration service for a wide variety of components, instruments and systems.

A standards calibration generally consists of obtaining the necessary corrections to be applied so that an instrument can be used with improved accuracy. In other cases, the standards calibration report is evidence of compliance with requirements for traceability to the National Bureau of Standards, important in government contracts.

The calibration report issued on every calibration gives the measurement conditions, a brief description of the technique used, the measurement uncertainty, the statement of traceability, and the actual test data, expressed in the most useful form. HP's standards capabilities cover almost all of the usual electronic quantities, at frequencies from dc to 40 GHz. An instrument of any manufacture can be calibrated, provided only that it is in good condition and shows the requisite stability.

Most customer standards calibrations are done by the Measurement Standards Laboratory at HP's headquarters in Palo Alto, California. As a further service, however, many of the HP field sales offices have been equipped with standards calibration capabilities for selected types of measurements.

Contact your local Hewlett-Packard field sales office for more information on the recalibration and standards calibration services available to you from HP.

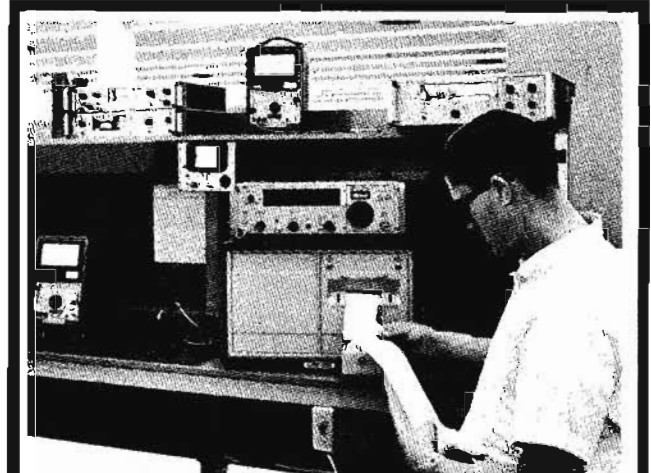

Recalibrations are performed by factory trained technicians at local field service facilities



HP's flying clocks are used by major world time keeping centers to calibrate their time standards.



The DC Room in HP's Palo Alto Standards Laboratory has temperature controlled within  $\pm 0.03^{\circ}\text{C}$ .

# Analytical Instruments for Chemistry

<b>Technical Information</b> . . . . .	<b>16</b>	<b>Specialized Analyzers</b> . . . . .	<b>31</b>
<b>Gas Chromatographs</b> . . . . .	<b>18</b>	Microwave Spectrometer	
Research		Carbon, Hydrogen, Nitrogen Analyzer	
High Efficiency		<b>Molecular Weight Determination</b> . . . . .	<b>34</b>
Laboratory		Vapor Pressure Osmometer	
<b>Preparative Gas Chromatographs</b> . . . . .	<b>27</b>	Membrane Osmometer	
Automatic		Automatic Viscometer	
Manual		Constant-Temperature Bath	
		Programmable Printer	
		<b>Chemical Accessories</b> . . . . .	<b>40</b>





Long recognized as the foremost supplier of electronic instruments for the engineer, Hewlett-Packard has more recently become an important source of laboratory instrumentation for the chemist. Chemical instrumentation from Hewlett-Packard reaches into four distinct areas:

### 1—Analytical gas chromatography

Although less than 15 years old, gas chromatography has taken over from classical and other instrumental methods the bulk of analytical work performed in chemical laboratories around the world. There is an excellent reason for the revolutionary effect of the gas chromatograph on analytical chemistry: no other method gets more accurate results, at greater speed and for less cost.

The F&M Scientific Division was a pioneer in gc development. Currently, it offers as complete a line gas chromatographs for all types of general and special applications as any manufacturer anywhere in the world. Its standard catalog includes more than 50 models.

### 2—Preparative gas chromatography

A natural outgrowth of analytical gas chromatography, the preparative gc is used not to analyze, but to isolate and collect quantities of pure chemicals.

For many types of chemicals, preparative gas chromatography is the fastest and most economical way to collect pure fractions. Its application is growing rapidly, especially as the result of technological improvements such as the F&M Scientific Division's 2½ and 4 inch OD preparative columns. The latter are capable of collecting in a few hours as much pure chemical as can be collected in several days by classical methods such as distillation.

### 3—Molecular weight determination

The special skills of the polymer chemist are needed in practically every scientific field today, whether food technology, bio-medical science, petroleum chemistry, etc. The F&M Scientific Division serves the polymer chemist with a line of instruments that help him make fast and

accurate molecular weight determinations of all sizes of molecules from 100 to several million.

### 4—Special analysis

In this category of Hewlett-Packard chemical instrumentation, there are currently two members. One is the HP Model 8400A Microwave Spectrometer, a new kind of instrument that gives information about a sample's molecular structure through measurement of absorption frequencies in the X-band. The other is the F&M Model 185 Carbon Hydrogen Nitrogen Analyzer which performs a complete elemental analysis of organic materials simultaneously and automatically.

### Analytical gas chromatographs

There are basically three types of analytical gas chromatographs currently being manufactured: a "research" instrument that incorporates all the state-of-the-art advances for high performance; a "laboratory" instrument which can be ordered with only basic equipment for routine analyses; and a "high-efficiency" instrument whose primary advantage is a large oven to accommodate U-tube glass

columns for analyzing sensitive materials.

F&M Scientific Division manufactures all three types. The choice should be based along functional lines as outlined in Table 1.

Besides the choice of instruments, the key to a good separation by gas chromatography is the selection of a proper column. This is a rather involved procedure since there are literally hundreds of available column materials. Much of the needed information for a correct choice is contained in F&M Scientific Division's Accessories Catalog No. 2.

### Preparative gas chromatographs

Most manufacturers classify preparative gas chromatographs by capacity, with general agreement that there are two types: those that accommodate small-capacity columns up to ¾ inch OD, and those that have larger capacity. This classification scheme does not apply to Hewlett-Packard preparative gc's, however, because they all accommodate, with equal ease, both the low-capacity and the high-capacity columns. The two Hewlett-Packard instruments differ principally in the degree of automation (see Table 2).

TABLE 1 — Analytical gas chromatographs

Type	Description	Detectors	Model No.	Price
Research	Highest quality; performance equal to the strictest research requirements; simultaneous installation of any three detectors and simultaneous operation of any two with dual column compensation; fully versatile and automated. With model 5756A, Three detectors can be operated simultaneously.	Dual flame (Df)	5751A	\$3300.00
		Dual thermal conductivity (Dtc)	5752A	3200.00
		Electron capture (Ec)	5753A	3500.00
		Df and Dtc	5754A	4300.00
		Df and Ec	5755A	4350.00
		Df and Dtc and Ec	5756A	5300.00
Laboratory GC	Low-cost dual-column instrument with modular design that permits easy addition of functional accessories.	Dual thermal conductivity	700-00	1095.00
		Dual flame	700-1099F	1700.00
		Electron capture	700-3099F	1845.00
		Micro cross section	700-4099F	1660.00
High-Efficiency GC	Dual U-tube glass columns, high-efficiency gc system, multiple detector options . . . for the analysis of hard-to-chromatograph materials.	Df	402	3700.00
		Df and Ec	402	
		(tritium)	+ opt. 02	4295.00
		Df and Ec (Ni63)	402	4550.00
			+ opt. 03	

Table 2 — Preparative gas chromatographs

Type	Description	Function	Model No.	Price
Preparative GC	True prep-scale instruments accommodate various sizes of prep columns between ½ and 4" OD, with built-in analytical capability.	Automatic	775	\$8800.00 (including recorder)
		Manual	776	3500.00



### Molecular weight instruments

In this area of analysis, Hewlett-Packard offers three different types of instruments, each intended for the determination of a particular kind of molecular weight, much faster and more accurately than is possible with the older classical methods. At one time or another, polymer chemists need the kind of information that each of these instruments is capable of producing for him. Once again, the choice between the various types of Hewlett-Packard instruments should be based on functional considerations, as outlined in Table 3.

### Special analyzers

The HP Model 8400A Microwave Spectrometer is an entirely new kind of instrument that looks into the molecular structure of a chemical compound through measurement of absorption frequencies in the X-band. Determination of bond angles, internuclear bond distances, dipole moments of molecules, intra-molecular effects such as nuclear quadrupole interactions and hindered rotations: all can be studied with the 8400A. Precise measurements of the intensity coefficient of the absorption curve and, consequently, of the amount of sample in a Stark cell can also be made.

The F&M Model 185 Carbon Hydrogen Nitrogen Analyzer has gained considerable acceptance among microchem-

ists in the three years since its introduction. The reason is its ability to perform, even under difficult circumstances, elemental analyses whose accuracy is well within the accepted allowable error of  $\pm 0.3\%$ , at a speed advantage of 4 to 8 times over classical methods.

### Hewlett-Packard services

The chemical instrumentation described in this section is backed by the quarter-century-old Hewlett-Packard tradition that "service starts before the sale and extends through the life of the instrument."

In implementing this policy, Hewlett-Packard offers a complete service for the analytical chemist.

*Technical Assistance*—Technically trained and qualified Chemical Instrumentation Sales Representatives are available in all major cities of the U.S., Canada and Europe to assist you in the selection, application and use of Hewlett-Packard instruments.

*Instrument Service*—Qualified and experienced service personnel, located in Hewlett-Packard Sales Offices and Service Centers, are on call to perform routine instrument maintenance or emergency repair.

*Training Courses*—Training courses in the application of the techniques of gas chromatography to bio-chemical and in-

dustrial analysis are held regularly at various Hewlett-Packard sales offices, as are courses on preparative chromatography.

Field workshops are also sponsored periodically by the F&M Scientific Division in cooperation with local institutions.

*Applications Research*—Corporate Applications Laboratory personnel at the Hewlett-Packard Chemical Instrumentation Division are constantly investigating new techniques and improving existing methods. The result of their applications work is made available to you through papers presented at technical meetings, in scientific journals and by comprehensive articles in Hewlett-Packard publications. Their services are also available to anyone with a question about the application of gas chromatography to specific analytical problems.

*Technical Publications*—Hewlett-Packard maintains constant communication with its Chemical Instrumentation customers about the use, maintenance and general upkeep of their instruments. This is accomplished through a variety of technical publications such as the Corporate Applications Laboratory's "Facts & Methods," a bimonthly publication that contains comprehensive papers and technical articles on chemical instrumentation.

Table 3—Molecular weight Instruments

Type	Description	Temperature	Model No.	Price
Vapor pressure osmometer	For number-average molecular weight determinations between 100 and 25,000; consecutive readings every 2-3 minutes; aqueous or non-aqueous operation.	25° to 130°C	302	\$2800.00
Membrane osmometer	For number-average molecular weight determinations between 10,000 and 1,000,000; automatic readings in 3 to 10 minutes; for aqueous or non-aqueous operation.	Ambient to 65°C Ambient to 130°C 5° to 65°C	501 502 503	4225.00 4975.00 5550.00
Auto-viscometer (5901B) (constant temp. bath 5910A)	For viscosity-average molecular weight determinations to precision of 0.005%; completely automated; optional printer-programmer.	Ambient to 150°C	5901B-5910A (incl. 4 detectors and constant temperature bath)	4140.00

# GAS CHROMATOGRAPH



## RESEARCH GC

Automated, multiple-detector for top performance  
Series 5750

Series 5750 Gas Chromatographs are automated yet fully versatile instruments whose performance is equal to the strictest research requirements. They are a second-generation 'top-of-the-line' instrument incorporating improvements that are available in no other gas chromatograph. Behind these improvements stand some quiet but important advances in the state-of-the-art that have made gas chromatography an even more useful tool than it was just two years ago when the 5750's predecessor was introduced. Parallel advances in F & M design make the 5750 still the most useful gas chromatograph around. We know of no other GC, regardless of price, that is capable of better qualitative and quantitative precision. Some of the most useful of the new design features of the Series 5750 GC are discussed below.

### Three detector positions

The Series 5750 permits the simultaneous installation and operation of any three detectors, from a choice of five interchangeable types: flame ionization, thermal conductivity, electron capture ( $H^2$ ), electron capture ( $Ni^{63}$ ) and micro cross-section.

Each of these detectors has been significantly redesigned to increase

its performance to the highest level possible on the basis of current technology.

### High-linearity dual flame detector

Tenfold better than the best previously reported, the 5750's new dual flame ionization detector is linear up to 2 ml of propane with a peak width at base of 7 seconds, peak current of  $2 \times 10^{-8}$  amp, equivalent to  $3.7 \times 10^{-4}$  grams C/sec.

Performance of the new detector was carefully evaluated on a 4-foot column with constant 30 ml/min carrier gas flow. Injections of propane gas in sample sizes from 10 to 2000 microliters were made with a calibrated syringe capable of  $\pm 1\%$  accuracy. Results indicate a deviation in detector response of less than  $\pm 10\%$  from theoretical at 2000 microliters, and much better at the smaller sample sizes.

The improvement in linearity is accompanied by a 30% increase in sensitivity with no increase in noise level and by a much greater tolerance to variations in gas flow. End result is that the 5750 flame detector permits the determination of trace components at much lower concentration levels . . . and better qualitative and quantitative reproducibility with large sample sizes.

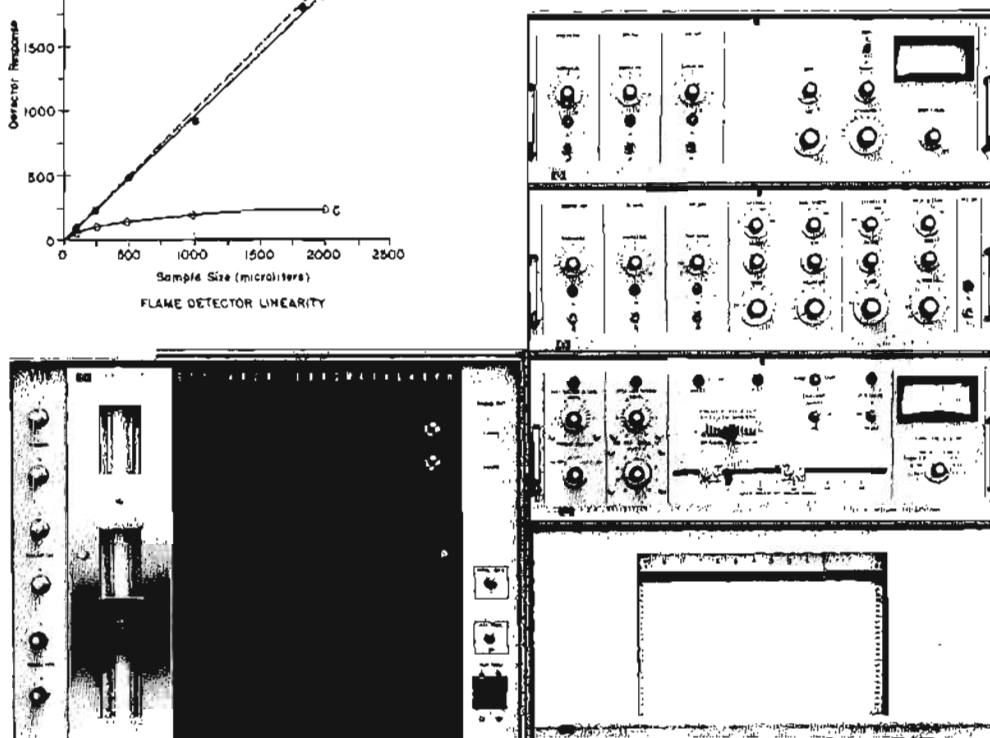
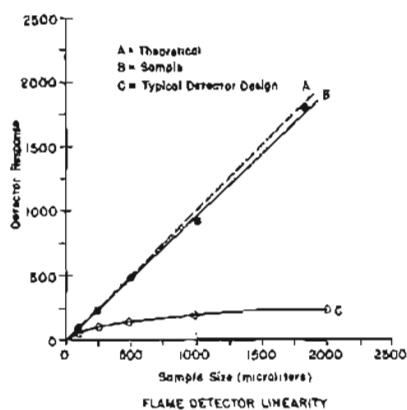

## RESEARCH GC

Automated, multiple-detector for top performance  
Series 5750



## GAS CHROMATOGRAPH

### High-stability dual thermal conductivity detector

A significantly improved baseline stability characterizes the new exclusive F & M dual thermal conductivity detector. In isothermal operation at any temperature up to 400°C, the new detector maintains a steady baseline within  $\pm 1\%$  per hour; in temperature-programmed dual-column operations, baseline drift is reduced to  $\pm 2\%$  from an equivalent 100% drift in the single-column mode (when using a 10% W-98 column).

There are four distinct reasons for the improvement in performance. The new cell geometry (1) isolates the cell from external temperature changes through a well-insulated and controlled buffer zone, (2) optimizes the length of transfer lines between column and detector, (3) eliminates thermal gradients within the cell through four symmetrically distributed heaters and (4) insures a high degree of flow insensitivity and systematic sweep-out of the cell even at low flows.

### High and low-temperature electron capture detectors

The 5750 offers a choice of two electron capture detectors: the standard tritium cell for operation up to 225°C and a new nickel cell for temperatures up to 360°C. Both feature the F & M variable pulsed voltage design for optimum sensitivity and linearity of response. The new Ni<sup>63</sup> cell is especially useful for the analysis of high-boiling components. Since it can be operated at higher temperatures than the column oven, deposition of column substrate and high-boilers on the cell is not likely.

The new cell has a useful life expectancy better than twice that of tritium cells (up to 5 years under moderate operating conditions) and a sensitivity of  $5 \times 10^{-22}$  gram of Lindane. Its thermal stability, built-in-over-heat protection and efficient shielding eliminate all possibility of health hazard from radioactivity.

### Versatile detector controls

Now available with either a single-channel or dual-channel electrometer — both with dual input capability for each channel — the 5750 offers the analyst a choice of three compact detector controls, one of which is suited exactly to his need and budget:

(1) *Single-channel electrometer* accommodates any one of the ionization detectors. Because it has dual-input capability, it operates the dual flame ionization detector either as a differential input (dual

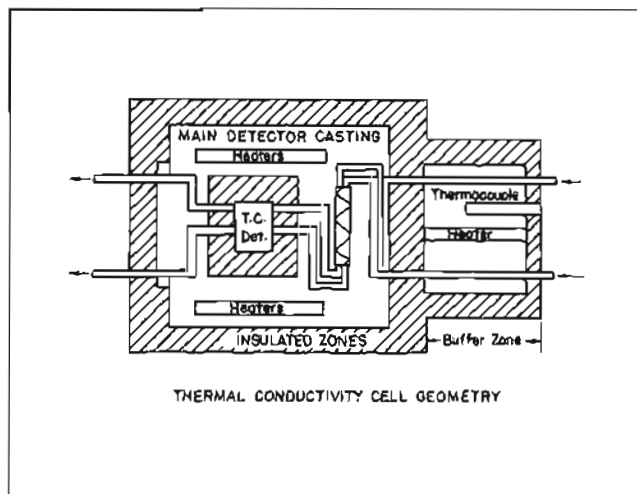

column compensation) or as a single input (single column operation). In either case, the electrometer provides a single output to the recorder.

(2) *Dual-channel electrometer* is also compatible with any of the ionization detectors. Since each channel has dual-input capability, this electrometer can be used for simultaneous operation of two detectors while permitting dual column compensation... as well as for independent operation of the two sides of the dual flame detector.

(3) *Thermal conductivity detector bridge* is designed specifically for use with the improved 5750 thermal conductivity detector. Noise has been reduced and integration capability has been improved.

### State-of-the-art oven and flow systems

This section of the 5750 has been completely redesigned in the light of recent state-of-the-art advances and a better understanding of its importance to the precision of gas chromatography.

**OVEN** — The 5750 oven possesses the best combination of fast response and excellent temperature uniformity of any commercially available GC. In the matter of response, it heats from 50°C to 400°C in ten minutes, cools from 400°C to 50°C in 8 minutes. Concerning temperature uniformity during isothermal operation, the gradient of the air around the columns does not exceed  $\pm 0.5\%$  at any temperature up to 400°C; in programmed operation, it does not exceed  $\pm 1.0\%$ . If column packing temperature is measured rather than the air surrounding the column, the gradient is considerably less (about  $\pm 0.25\%$  isothermally), as shown in the diagram.

**INJECTION PORT** — Entirely new in design, the 5750's injection port permits true on-column injection, eliminates dead volume, minimizes thermal gradients, allows minimum sample backflash, and provides for the use of inserts.

**FLOW CONTROLLER** — A newly designed flow controller maintains flow rates with a precision about five to ten times better than that obtainable with presently available commercial flow controllers.

### Automated operation

The Series 5750 oven temperature control system is designed to give the analyst complete versatility of operation, from manual isothermal to fully automatic programmed runs.

When in automatic operation, the 5750 is capable of repeating all the conditions of analysis without manual resetting of any kind. The entire cycle is automatic, from temperature programming, through variable time delays, to automatic cooling and re-equilibration at the starting temperature.

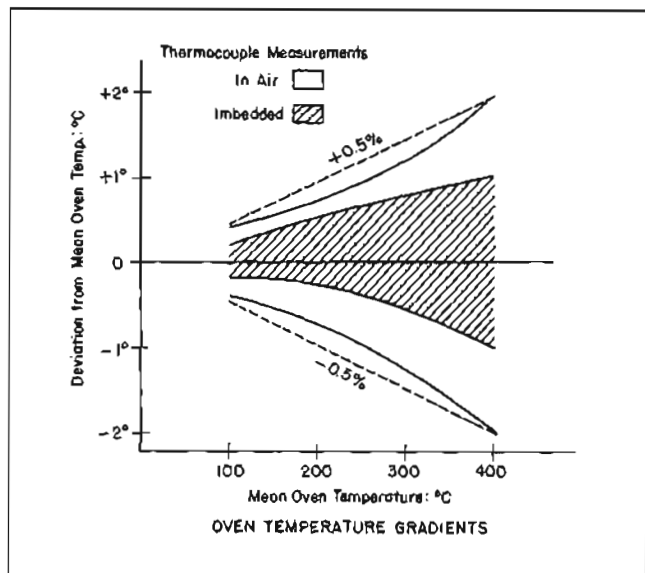

**GAS CHROMATOGRAPH****RESEARCH**

Automated multiple-detector for top performance  
Series 5750

**Specifications, Series 5750****Detectors****Flame ionization**

Dual detector unit.  
Extended linear operating range of over  $10^7$  with hydrocarbon sample.  
Operating temp.: ambient to  $500^\circ\text{C}$ .  
Voltage-stabilized power regulator.  
Flame igniter.

**Thermal conductivity**

Dual detector unit.  
Operating temp.: ambient to  $450^\circ\text{C}$ .  
Carrier gas: helium, 5-200 ml/minute.  
High-sensitivity, spiral flow-thru tungsten-rhenium filament.  
Power-proportioning temp. controller.  
Relatively insensitive to flow changes.  
"Detector protector": carrier gas pressure reduction automatically cuts off filament current.

**Electron capture\***

Pulsed voltage: 5, 15, 50 and 150 microsecond intervals.

**Electron source:**

- (1) 200 millicuries tritium.  
operating temp.: ambient to  $225^\circ\text{C}$ .
  - (2) 2 millicuries  $\text{Ni}^{63}$   
operating temp.: ambient to  $360^\circ\text{C}$ .
- Integral overheat protection.  
Carrier gas: argon-methane or helium.  
Purge gas: argon-methane.  
Voltage-stabilized power regulator.

**Micro cross-section\***

Electron source: 200 millicuries tritium.  
Operating temp.: ambient to  $225^\circ\text{C}$ .  
Integral overheat protection.  
Carrier gas: hydrogen or helium.  
Purge gas: none required.  
Voltage-stabilized power regulator.

**Injection port**

Dual unit.  
Flash vaporizer.  
Operating temp.: ambient to  $500^\circ\text{C}$ .  
On-column injection.  
Accepts replaceable inserts and special sampling devices.  
Splitter system (optional)  
Voltage-stabilized power regulator.

**Oven**

Temperature range: ambient to  $500^\circ\text{C}$  with detectors and injection port at  $100^\circ\text{C}$ .  $80^\circ\text{C}$  is minimum oven temperature possible with detectors and injection port at  $275^\circ\text{C}$  to  $300^\circ\text{C}$ .  
Isothermal gradients:  $\pm 0.5\%$  max. (measured in air).  
Programmed gradients:  $\pm 1.0\%$  at  $10^\circ\text{C}$  per minute.  
Max. heating rate:  $50^\circ\text{C}$  to  $400^\circ$  in 10 minutes with 120 Vac across the heaters.  
Cooling rate:  $400^\circ\text{C}$  to  $50^\circ\text{C}$  per minute.  
Linear programmer: 10 rates from  $1^\circ$  to  $60^\circ\text{C}/\text{minute}$ .  
Simultaneous installation of up to 3 detectors.  
Capacity: up to 150 feet of  $1/4$  inch OD column and proportional lengths of  $1/16$ ",  $1/8$ " and  $1/2$ " OD columns.  
Power-proportioning temperature controller.  
Automated programming cycle including cooling.

**Columns**

Packed: glass (limited to 2-10' columns or 1-20' column); metal.  
Analytical or preparative.  
Outside diameter:  $1/16$ ",  $1/8$ ",  $1/4$ " and  $1/2$ " inch.  
Length: up to 150 feet,  $1/4$ " inch OD column on average 9-inch diameter coil.

**Temperature control**

Separate controls for all heated components.  
Readout on indicating pyrometer with eight-position selector switch.  
Direct setting in degrees of column oven temperature.

**Gas flow system**

Dual-column design with dual injection and exit ports and five flow paths:

- (1) dual compensating columns
- (2) two columns in series
- (3) two columns in parallel
- (4) single analytical column
- (5) single preparative column

Gas supply: fittings and plumbing for four gases:

- (1) Carrier Gas  
 $1/8$ -inch entrance fitting  
drying tube  
two 3-inch matched rotameters with calibration curve for flow-range 0-200 ml/min @ 30 psig helium  
two differential flow controllers with needle valve adjustment
- (2) Hydrogen Gas (flame ionization models only)  
 $1/8$ -inch entrance fitting  
adjustable-matched restrictors (flow rates up to 125 ml/min)  
two optional 3-inch rotameters  
needle valve shut-off control
- (3) Air (flame ionization models only)  
 $1/8$ -inch entrance fitting  
adjustable-matched restrictors (flow rates up to 500 ml/min)  
two optional 3-inch rotameters
- (4) Auxiliary Gas  
 $1/8$ -inch entrance fitting  
needle valve for adjustment and shut-off

**T. C. bridge**

Continuous current adjustment and readout.  
Coarse and fine zero controls.  
Attenuator for bridge output (12 positions to 1024).  
Output polarity switch.  
Separate output for electronic integrator.  
Line-operated power supply.

**Electrometer**

Single and dual-channel models.  
Input (each channel): dual flame ionization, single flame ionization, electron capture or micro cross-section detectors.  
Sensitivity:  $4.0 \times 10^{-12}$  A full scale.  
Dynamic range: 50,000 to 1 on all range resistors except range 1.  
Total linear range of  $4.0 \times 10^{-14}$  to  $10^{-9}$  A.  
Noise: less than 1% at most sensitive operation (detector cable disconnected).  
Coarse and fine zero controls, with background suppression of  $10 \times 10^{-9}$  A.  
Input and output attenuation controls.  
Line-operated power supply.

**Electrical**

Supply requirements: 105-125 V, 60 Hz, single phase (50 Hz optional); 19 A max. at 115 V for normal operation.  
Circuit breaker on both sides of main power line.  
All key circuits fused.  
Ground through power cable.

\*AEC license required; Hewlett-Packard Sales Offices supply necessary license application information.

**RESEARCH GC**  
Automated, multiple-detector for top performance  
Series 5750



**GAS CHROMATOGRAPH**

How to order		Modules (customer-installed)		
Ordering No.	Description	Price		
<b>Complete Instruments</b>				
5751A	Dual flame detector instrument with single-channel electrometer.	\$3300.00	5760A Dual-channel electrometer (consists of two dual-input single-output channels; permits dual column compensation while operating two ionization detectors). \$ 950.00	
5752A	Dual thermal conductivity detector instrument with bridge.	3200.00	5761A Single-channel electrometer (dual-input single-output, for use whenever an additional electrometer channel is required) 500.00	
5753A	Electron capture detector instrument with single-channel electrometer.	3500.00	5762A Electron capture (tritium) detector and all necessary hardware for installing it on Model 5751A or 5754A (allows alternate operation** of either ionization detector). 695.00	
5754A	Dual flame and dual thermal conductivity detector instrument* with single-channel electrometer, bridge and 2 two-way effluent splitters.	4300.00	5763A Same as Model No. 5762A except that detector contains Ni <sup>63</sup> foil 950.00	
5755A	Dual flame and electron capture (tritium) detector instrument* with dual-channel electrometer and one two-way effluent splitter.	4350.00	5764A Dual thermal conductivity detector, bridge, and all necessary hardware for installing it on a Model 5751A* (incl. 2-way splitter), Model 5753A* (incl. 2-way splitter) or Model 5755A* (incl. 3-way splitter) 1020.00	
5756A	Dual flame, dual thermal conductivity and electron capture (tritium) detector instrument* with dual-channel electrometer, bridge, and a two-way and a three-way effluent splitter.	5300.00	5765A Electron capture (tritium foil) detector, single-channel electrometer, two-way splitter and all necessary hardware for installing it on a Model 5752A* 1395.00	
7127A-20-21	plus (one) 17503A-01-04† Moseley single pen; strip chart recorder; right hand zero; 10" chart; 1 mV input module (filtered) with detector selection switch; gray panels; 60 Hz operation.	1,100.00	5766A Same as Model No. 5765A except detector contains Ni <sup>63</sup> foil 1650.00	
7128A-20-21	plus (two) 17503A-01-04† Moseley two pen; strip chart recorder; right hand zero; 10" chart; 1 mV input module (filtered) for each channel with detector selection switches; gray panels; 60 Hz operation.	1,650.00	5767A Micro cross-section detector and all necessary hardware for installing it on Models 5751A and 5754A (allows alternate operation** of either ionization detector) 575.00	
*Fos 50 Hz operation on input Module 17503A, also add -02.			5768A Micro cross-section detector, single-channel electrometer, two-way splitter and all necessary hardware for installing it on Model 5752A* 1325.00	
<b>Options (factory-installed)</b>				
01	Second electrometer channel for Models 5751A, 5754A and 5756A (allows alternate or simultaneous* operation of two ionization detector systems, or independent operation of both sides of the dual flame detector)	450.00	5769A Dual flame detector, single-channel electrometer, 2 two-way splitters and all necessary hardware for installing it on Model 5752A (allows alternate or simultaneous* operation of both detectors) 1125.00	
02	Dual thermal conductivity detector, bridge and two-way effluent splitter installed on Model 5753A*	1000.00	5770A Dual flame detector and all necessary hardware for installing it on Model 5753A (allows alternate** operation of either detector) 490.00	
03	Electron capture detector (tritium), single-channel electrometer and two-way effluent splitter installed on Model 5752A*	1300.00	<b>Accessories (customer-installed)</b>	
04	Same as Option 03* except that detector contains a high-temperature Ni <sup>63</sup> foil	1550.00	19030A Blackflush valve 95.00	
05	Micro cross-section detector installed on Models 5751A and 5754A; instrument capable of alternate operation of either ionization detector	475.00	19031A Heated collection vent*** 100.00	
06	Micro cross-section detector, single-channel electrometer and two-way effluent splitter installed on Model 5752A*	1225.00	19032A Dual-rotameter kit for air and hydrogen flows 300.00	
07	To substitute Ni <sup>63</sup> electron capture detector in Model 5753A, 5755A or 5756A	225.00	19034A Effluent splitter 175.00	
08	Inlet splitter (installed)	125.00	19035A Inlet splitter 125.00	
09	Backflush valve (installed)	95.00	19047A Gas sampling valve without shut-off valves 225.00	
10	Heated collection vent*** (installed)	100.00	19048A Gas sampling valve with shut-off valves 275.00	
11	Dual rotameters for air and hydrogen flows (installed)	300.00	*Capable of simultaneous operation of two detectors when equipped with 2 single-pen or one dual-pen recorder.	
12	Gas sampling valve without shut-off valve (installed)	225.00	**Capable of simultaneous operation of two detectors when equipped with additional electrometer and recorder channels and with appropriate effluent splitter.	
13	Gas sampling valve with shut-off valves (installed)	275.00	***Requires a two-way effluent splitter when used with a single detector instrument.	
15	Effluent splitter	175.00	<b>7127A/7128A Options (factory-installed at time of purchase)</b>	
21	230 V, 50 Hz operation	82.00	01	High-low limit switches on Model 7127A, and channel one only on Model 7128A. 50.00
			05	115 or 230 V, 50 Hz operation. N/C
			04	Left-mounted event marker. 35.00
			06	Both left and right-mounted event marker. 70.00
			07	Disc integrated <sup>1</sup> (one channel only on Model 7128A). 585.00
			11	Carrying handle. 25.00
			12	Mounted in cabinet compatible with F & M gas chromatographs. <sup>2</sup> 100.00

<sup>1</sup> Disc integrator and right-mounted event maker cannot be installed on same recorder.

<sup>2</sup> No charge when ordered with Series 402 or 5750 instruments.

# GAS CHROMATOGRAPH



## HIGH EFFICIENCY GC

Multi-detector, dual U columns, all-glass system  
Series 402

Designed specifically for the analysis of thermally sensitive, polar and other hard-to-chromatograph materials, Series 402 High-Efficiency Gas Chromatographs incorporate a number of unique instrument characteristics that minimize or eliminate the decomposition or adsorption of unstable materials.

### Straight-through on-column injection

The 402's unique injection port is characterized by a straight-through design which has substantial advantages over the more common T-design:

a — it accomplishes *true on-column injection* since the syringe discharges the sample at least one inch into the column, rather than in a separate chamber, thus essentially eliminating sample contact with metal in the hot injection zone;

b — a stream of high-velocity carrier gas *sweeps the entire injection area* including the inside surface of the septum, thus preventing sample holdup or condensation on the septum;

c — it eliminates the dead volume and sample backflash that are characteristic of T-type designs, thus producing an *ideal "plug" injection*.

### Multiple-detector, dual-column system

Series 402 GC's are dual-column instruments with multiple detector capability. Each of its two-columns can be equipped with an effluent splitter, thus giving the analyst a choice of functions that includes:

- a — single-column operation
- b — concurrent runs on two different columns
- c — dual-column baseline compensation
- d — simultaneous operation of two detectors
- e — simultaneous analytical/preparative runs for the collection of individual separated components.

### No dead spaces

Dead space (*i.e.* stagnant carrier gas) has been virtually eliminated throughout the 402's GC system especially in the four critical areas:

- a — *injection port* ... carrier gas sweeps the whole area;
- b — *where column joins injection port* ... on-column injection eliminates this dead space;
- c — *where column joins detector* ... the 402's primary detectors attach directly to the column end, eliminating this dead space;
- d — *detectors* ... all 402 detectors are based on flow-through design and are devoid of dead space.

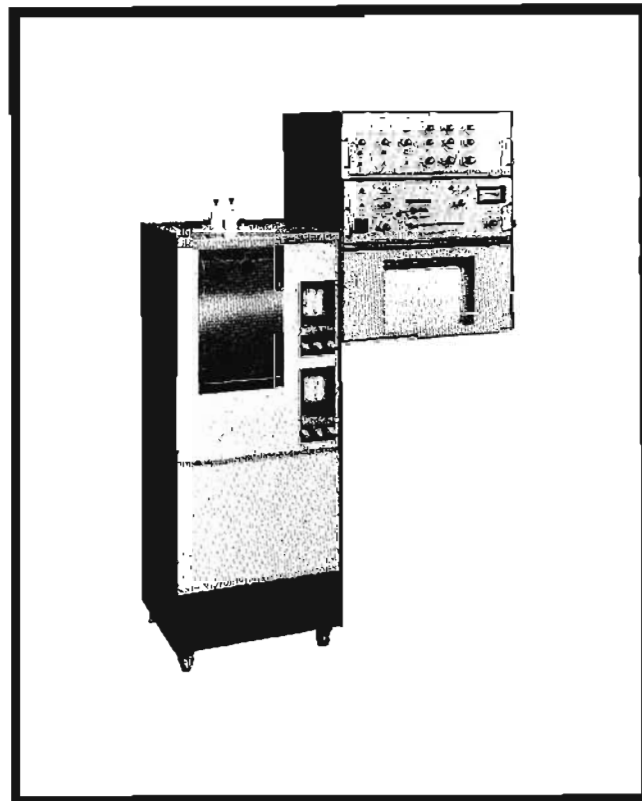
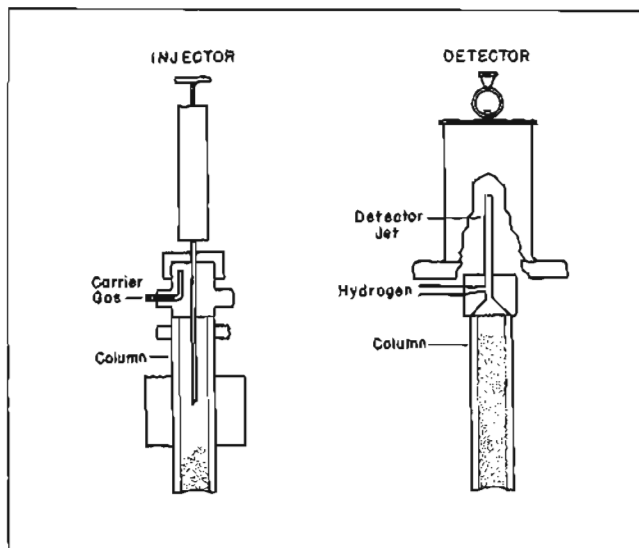

### All-glass system

The 402 can be equipped so that the sample "sees" virtually nothing but glass, from injection directly on glass, through a glass column and a glass and Teflon effluent splitter, to the detector; or into a Teflon collection system that attaches directly to either of the instrument's auxiliary detector positions.

### High-turbulence U-tube oven

Two 3000 RPM centrifugal blowers at opposite ends of the oven create a high-turbulence environment for two 6-foot U-tube columns. Twin heaters are mounted in the blower stream to eliminate thermal lag and create uniform temperatures in the immediate column environment (gradient less than 2°C top to bottom).

### Performance

Even with the most sensitive materials — pesticides, steroids, vitamins, organo metallics, polyfunctional industrial organic chemicals — the 402 produces a chromatogram that bears all the marks of a high-efficiency instrument:

*peak symmetry* so fine that there is no trace of tailing even at picogram levels of detection;

*column efficiency* so high (often exceeding 700 theoretical plates per foot) that even the most difficult separations are completed on as little as 12 feet of column;

*elimination of component loss* so complete that steroids give accurate quantitative response, even at the nanogram level;

*sensitivity* so high that picogram quantities of many materials are detected without even extending the detector;

*dual column operation* so versatile that it permits baseline compensation, or concurrent analytical runs on two different columns, or simultaneous operation of up to four detectors, or combined analytical/preparative runs.

## Specifications

### Gas flow system

#### Facilities for handling four gases:

- (1) Carrier gas: dual differential flow controllers and needle valves; dual matched 3-inch rotameters sized for helium flow range of 0-250 cc/min at 40 psig; drying tube.
- (2) Hydrogen: dual needle valves; dual matched 3-inch rotameters sized for flow range of 0-100 cc/min.
- (3) Air: dual needle valves; dual matched 3-inch rotameters sized for flow range of 0-700 cc/min.
- (4) Purge: needle valve, drying tube.

### Column system

Dual on-column injection with removable flash heaters. Dual columns, each 4 or 6-feet, glass U-shaped with 3 mm ID and 6 mm OD (longer glass columns of paper clip configuration and metal columns may also be used).

**Oven:** stainless steel shell with double insulation 1½" thick; two low-mass heaters each 800 watts; two blowers; thermal fuse.

**Effluent splitter (optional):** annular split design; made of glass with Teflon\* insert for min. sample contact with metal; infinitely variable split ratio of approx. 1:1 to 20:1.

### Detectors

**Dual flame ionization (standard):** low-mass design; minimum sample contact with metal.

**Twin flame:** for independent operation of both sides of the dual flame detector.

**Electron capture:** choice of tritium cell for operation up to 225°C and nickel cell for temperatures up to 360°C; tritium cell has 200 millicuries source and nickel cell, 2 millicuries; pulsed voltage type with variable pulse interval of 5, 15, 50 and 150 microseconds; built-in overheat protection; tritium cell of Teflon and stainless steel; nickel cell made of ceramic and stainless steel; no venting required below 150°C; requires specific AEC license.

**Micro cross-section:** 200 millicuries tritium source; dc voltage type; no purge gas required; built-in overheat protection; made of Teflon and stainless steel; no venting required below 150°C; requires specific AEC license.

### Electrometers

**Sensitivity:**  $4.0 \times 10^{-12}$  A full scale on 1 mV recorder.

**Linear dynamic range:**  $4 \times 10^{-11}$  to  $1 \times 10^{-9}$  A.

**Background suppression:**  $10^{-4}$  A, supplied by battery.

**Input attenuation:** 4 powers of 10.

**Output attenuation:** 8 multiples of 2.

**Output for potentiometric recorders:** 0-1 mV.

### Temperature controls

**Oven:** power-proportioning controller and linear programmer with 12 rates from 0.5 to 30°C/min.; max. temp. of 400°C; max. temperature gradient of 2°C; max. heating time from ambient to 400°C is 40 min., cooling from 400°C to 50°C in 15 min.; program delay timer variable 0-20 min.

**Injection port:** voltage-stabilized power regulator; max. temp. of 450°C.

**Flame detector:** voltage-stabilized power regulator; max. temp. of 425°C.

**Auxiliary detector:** voltage-stabilized power regulator; max. temp. of 225°C.

**Readout:** indicating pyrometer and five-position selector switch.

### Physical

**Size:** oven module: 48" high, 18" wide, 19" deep; control cabinet: 33" high, 21" wide, 22" deep.

**Weight:** oven module: 180 pounds; control cabinet with recorder: 215 pounds.

### Electrical

**Power requirements:** 105-125 V, 50 or 60 Hz (specify on order), 20 A.

**Fuses:** main power has circuit breakers on both sides of line; key circuits are fused.

\* DuPont's registered trademark for fluorocarbon resin

## How to order

Ordering No.	Description	Price
<b>Complete Instruments</b>		
402	Basic dual flame ionization detector instrument with single-channel electrometer*, 115 V, 50 or 60 Hz (specify)	\$3700.00
... With choice of recorders (specify):		
7127A-20-21 plus (one) 17503A-01-04†	Moseley single pen; strip chart; right hand zero; 10" chart; 1 mV input module (filtered) with detector selection switch; gray panels; 60 Hz operation	1100.00
7128A-20-21 plus (two) 17503A-01-04†	Moseley two pen; strip chart; right hand zero; 10" chart; 1 mV input module (filtered) for each channel with detector selection switches; gray panels; 60 Hz operation	1650.00

† For 50 Hz operation on input module 17503A, also add -02.

### Options

01	Adds second electrometer channel (for alternate or simultaneous** operation of two ionization detector systems, or for independent operation* of both sides of a dual flame detector)	750.00
02	Adds detector and all necessary hardware for electron capture (tritium foil) detection***	595.00
03	Same as Option 02 except that detector contains a high-temperature Ni <sup>63</sup> foil	850.00
04	Two-way effluent splitter	95.00
21	230 V, 50 Hz operation	82.00

### Additional Items (customer-installed)

5801A	Single-channel electrometer with dual-input single-output (for use whenever an additional electrometer channel is required)	800.00
5802A	Detector and all necessary hardware for adding tritium electron capture detection	695.00
5803A	Same as Model No. 5802A except that detector contains Ni <sup>63</sup> foil	950.00
5804A	Detector and all necessary hardware for adding micro cross-section detection	575.00
5805A	"U" column oven with dual flame detector for use with Series 810 Gas Chromatograph	1995.00

### Accessories

19050A	Two-way effluent splitter	95.00
19055A	Total collection system	120.00

### Moseley Model

#### 7127A/7128A Options (factory-installed at time of purchase)

01	High-low limit switches on Model 7127A and channel one only on Model 7128A	50.00
03	115 or 230 V, 50 Hz operation	n/c
04	Left-mounted event marker	35.00
06	Both left and right-mounted event marker	70.00
07	Disc integrator**** (one channel only on Model 7128A)	585.00
11	Carrying handle	25.00
12	Mounted in cabinet compatible with F & M gas chromatographs*****	100.00

\* Independent operation of both sides of the dual flame detector (twin flame) can be obtained through use of a second electrometer channel (Option 01) and a dual-channel recorder.

\*\* Requires two single-channel or one dual-channel recorder.

\*\*\* For simultaneous operation, an effluent splitter, second electrometer channel and second recording channel are required.

\*\*\*\* Disc integrator and right-mounted event marker cannot be installed on same recorder.

\*\*\*\*\* No charge when ordered with Series 402 or 5750 instruments.



# GAS CHROMATOGRAPH



## LAB GAS CHROMATOGRAPH

Low-cost modular dual-column GC  
Series 700

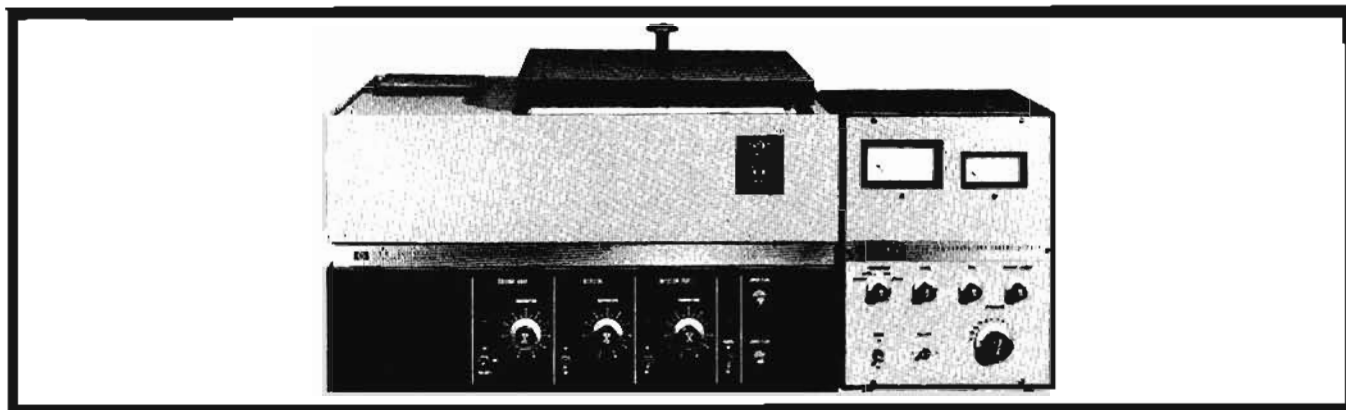

Series 700 Gas Chromatographs are modular in design. In addition to the basic instrument, they are available with a full line of interchangeable detectors and compatible functional accessories. Designed to an uncompromisingly high performance standard, the 700 line nevertheless appeals to the chemist with a limited laboratory budget because of the low price of the basic instrument, less than \$1100 (f.o.b. Avondale).

### The basic instrument

The basic Series 700 unit is an isothermal gas chromatograph with a flexible two-column design that permits single column, series or parallel two-column operation as well as dual column compensation. The 700 is also capable of manual temperature programming and high-temperature operation, with independent control of injection port, detector, and oven to 400°C. Injection can be either directly onto the column or into a flash vaporizer. All Series 700 oven modules are equipped with a voltage-stabilized power regulator. An adapter plate and switch permit bypassing the standard power regulator and allows the plug-in use of either a Model 220 Temperature Controller or a Model 240 Temperature Programmer for oven control (both are described later). Except for Model 700-00, all Series 700 instruments are equipped with flow controllers.

### Interchangeable detectors

Regardless of which detector is initially ordered with the instrument, the analyst has the option of replacing it with any one of the four detector attachments that are presently available: dual thermal conductivity, dual flame, electron capture and micro cross-section. All are completely interchangeable one with the other. The whole procedure of interchanging detectors takes only minutes for a skilled person, a little longer for a novice.

Each detector attachment for Series 700 instruments is packaged as a kit with all the necessary hardware for installation. The same basic instrument is used for all detectors, thus affording the analyst a multi-detector instrument at low cost.

### Modular accessories

One of the important advantages of the modular-design Series 700 Gas Chromatographs is the fact that they can be ordered "stripped," to meet the requirements of a low budget... and still permit the later addition of convenience and performance features as the budget permits. A long list of accessories that are custom-fitted to the 700 make this possible; the more important ones are described below.

**Power-proportioning oven controller:** an adapter plate and switch permit bypassing the standard power regulator and allows the plug-in use of either a Model 220 temperature controller or a Model 240 temperature programmer for oven temperature control. The Model 220 controller is a solid state device that modulates power input to the oven heating element in proportion to the actual need for heat.

**Temperature programmer:** the Model 240 Linear Programmer provides precise programming of Series 700 oven heating rates. It also incorporates a power-proportioning controller described above. The programmer provides 12 discrete heating rates from 0.5 to 30°C/min.

**Power supply for TC detectors:** an F & M power supply was specifically designed for thermal conductivity circuits and packaged to fit the Control Module of the Series 700. It can be set for 15 volts to supply type W filaments or for 30 volts to supply type WX filaments.

It converts 105-125 V ac (50 or 60 Hz) to a regulated dc output through full-wave solid-state circuitry that incorporates regulation and filtering for stability. It has 300 mA capacity.

**Flow measurement:** one or two rotameters, installed on the Oven Module, continuously and accurately indicate the gas flow rate through both columns.

**Flow controllers:** factory- or customer-installed, this option includes one or two diaphragm-actuated control valves installed in the Oven Module to keep the flow of carrier gas

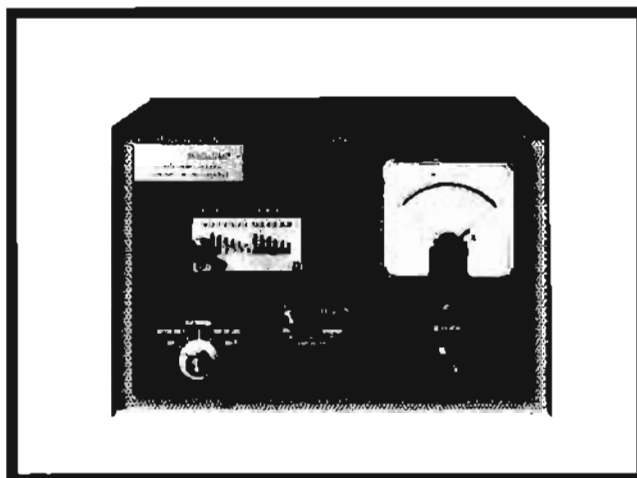

# LAB GAS CHROMATOGRAPH

## Low-cost modular dual-column GC

### Series 700



# GAS CHROMATOGRAPH

constant regardless of changes in column temperature or viscosity. It replaces the standard needle valve flow control of Series 700 instruments.

### Performance

Because of its four interchangeable detector options, each Series 700 Gas Chromatograph has the analytical potential of four separate instruments:

(1) When equipped with the *dual thermal conductivity detector*, the Series 700 is sensitive to almost any organic or inorganic substance, often at the microgram level and at programmed temperatures up to 100°C higher than a single column instrument.

(2) The *dual flame ionization detector*, well known in its single column configuration for very high sensitivity to organic compounds, extends this ability to programmed high-temperature analysis by reducing the effects of column substrate bleeding.

(3) Specific to halogenated compounds, organo-metallics and polycyclic hydrocarbons, the *electron capture detector* option makes the 700 more sensitive to these compounds than any known method of detection, often picking up as little as 10 picograms.

(4) The *micro cross-section detector* gives a calculable quantitative response to any material in the carrier gas and is thus a very useful tool for quantitative analysis.

### Series 700 specifications

#### Gas flow system

Dual column design with dual injection and exit ports and five flow paths:

- (1) dual compensating columns
- (2) two columns in series
- (3) two columns in parallel
- (4) single analytical column
- (5) single preparative column

**Gas supply requirements:** regulated 0-100 psi.

#### Gas supply connections:

- (1) for thermal conductivity models:
  - one connection for carrier gas with needle valves for each column (flow controllers optional).
- (2) for flame ionization models:
  - one connection for carrier gas with needle valves for each column (flow controllers optional).
  - one connection for hydrogen, split through matched snubbers; needle valves for each flow
  - one connection for combustion air split through matched snubbers
- (3) for electron capture and micro cross-section models:
  - one connection for carrier and purge gas with needle valve (flow controller optional).

#### Columns

**Standard column sizes:** any OD from 1/8 to 1/2 inch. Large oven holds up to 150 feet of 1/4-in. OD column. Accepts packed metal, glass or preparative columns.

#### Detectors

##### Four interchangeable detectors:

- (1) Thermal conductivity:
  - dual detector

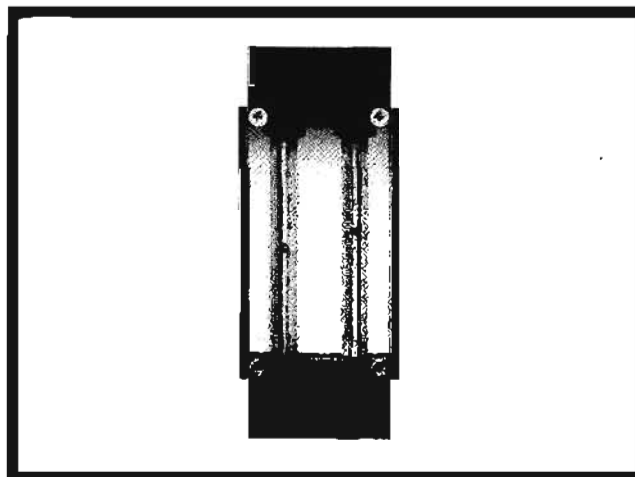

four-wire hot filament type, 150 mA range  
W or WX filament standard

- (2) Flame ionization:
  - dual detector
  - low-mass design on cast aluminum base
  - manual flame igniter
- (3) Electron capture:
  - pulsed voltage type with variable interval of 5, 10, 50 and 150 microseconds
  - 200 millicuries tritium source with integral overheat protection
  - no venting required below 150°C
  - specific AEC license required
- (4) Micro cross-section:
  - DC voltage type
  - 200 millicuries tritium source with integral overheat protection
  - no venting required below 150°C
  - specific AEC license required

#### T. C. bridge

Continuous current adjustment and readout  
Coarse and fine zero adjustment  
Attenuator (12 positions to 1024)  
Output polarity switch

#### Power requirements:

for W filaments—15 V dc, 300 mA  
for WX filaments—30 V dc, 300 mA

#### Electrometer

**Input:** F & M dual flame ionization, electron capture or micro cross-section detectors.

**Sensitivity:**  $1 \times 10^{-11}$  A full scale.

**Linearity:**  $\pm 1.5\%$  full scale over entire range.

**Time constant:** less than 1 second at full sensitivity.

**Noise:** less than  $10^{-13}$  A.

**Drift:** less than 1% full scale per hour.

Live zero and background suppression.

**Power requirements:** self-powered from integral 135 V battery supply; no ac.

#### Temperature control

Separate controls for detector, oven and injection port

# GAS CHROMATOGRAPH



## LAB GAS CHROMATOGRAPH

Low-cost modular dual-column GC

Series 700

**Detector:** voltage-stabilized variable power regulator, (power-proportioning controller standard with WX filament t.c. detector).

range: ambient to 400°C.

heater rating: 170 W.

fuse: 1 A.

**Oven:** voltage-stabilized variable power regulator (power-proportioning controller and linear programmer optional).

range: ambient to 400°C.

heating rate: 15 min. ambient to 400°C.

cooling rate: 10 min. 400°C to ambient.

heater rating: 1050 W (1200 W with 220 or 240).

fuse: 15 A, plus temperature limit fuse.

**Injection port:** variable power transformer.

range: ambient to 400°C.

heater rating: 85 W.

fuse: 1 A.

**Temperature readout:** indicating pyrometer and five position selector switch.

### Physical

**Oven module:** 25" wide, 16½" high, 20½" deep; 76 lbs net.

**Bridge module:** 10" wide, 13½" high, 10½" deep; 12 lbs net.

**Electrometer module:** 10" wide, 13½" high, 10½" deep; 18 lbs net.

### Electrical

**Oven module:** 110-125 V ac, 50-60 Hz, 20 A.

**Bridge module:** (as noted above).

**Electrometer module:** self-powered.

**Fuses:** main power has circuit breaker; all key circuits separately fused.

Ordering  
No.\*

Description

Price

700-3099F	Electron capture detector (EC) instrument with dual flow controllers.	1,845.00
700-3199F	EC instrument with dual flow controllers and proportioning oven temperature controller.	2,240.00
700-4099F	Micro cross-section detector (MCS) instrument with dual flow controllers.	1,660.00
700-4199F	MCS instrument with dual flow controller and proportioning oven temperature controller.	2,055.00
700-42	MCS instrument with dual flow controllers and linear temperature programmer.	2,305.00

### Attachments

700-A-091	Dual TC detector with W filaments, bridge, 15-30 volt power supply, detector oven and installation hardware.	545.00
700-A-291	Dual TC detector with WX filaments, bridge, 15-30 volt power supply, detector oven and proportioning temperature controller and installation hardware.	795.00
700-A-1**	Dual FI detector and hardware.	450.00
700-A-3**	EC detector, pulser, temperature limit controller and installation hardware.	695.00
700-A-4**	MCS detector, temperature controller and installation hardware.	475.00
700-A-99E	Electrometer.	350.00

### Kits

700-0016F	Oven with dual TC detector and bridge for use with F & M Model 609.	1,445.00
700-1095F	Oven with dual FI detector and electrometer for use with F & M Model 500.	1,700.00
700-1096F	Oven with dual FI detector and electrometer for use with F & M Model 609.	1,700.00
700-1097F	Oven with dual FI detector and electrometer for use with F & M Model 720.	1,700.00

\*If Moseley Recorder is desired, specify this item separately on your order from the following table.

\*\*If attachment is for use with Model 700 that is not equipped with electrometer, Part No. 700-A-99E must be ordered also.

How to order		
Ordering No.*	Description	Price
<b>Complete instruments</b>		
700-00	Dual thermal conductivity detector (TC) instrument.	\$1,095.00
700-0019F	Dual TC instrument with power supply and dual flow controllers.	1,445.00
700-0199F	Dual TC instrument with power supply, dual flow controllers and proportioning oven temperature controller.	1,840.00
700-2419F	Dual TC instrument with WX filaments, power supply, dual flow controllers and proportioning detector temperature controller.	1,695.00
700-021	Dual TC instrument with power supply, dual flow controllers and linear programmer.	2,090.00
700-231	Dual TC instrument with WX filaments, power supply, dual flow controllers, proportioning detector temperature controller and linear programmer.	2,340.00
700-1099F	Dual flame ionization detector (FI) instrument with dual flow controllers.	1,700.00
700-1199F	Dual FI instrument with dual flow controllers and proportioning oven temperature controller.	2,095.00
700-12	Dual FI instrument with dual flow controllers and linear programmer.	2,345.00

### Moseley strip chart recorders

Recommended for GC use: There are many options available to increase the versatility of your Moseley recorder. F & M recommends the following set of options as most convenient for use with a gas chromatograph. Prices include all recommended options.

Description	Ordering No.	Price
Single pen; strip chart; right hand zero; 10° chart; 1 mV input module (filtered) with detector selection switch; gray panels; 60 Hz operation.	7127A-20-21 plus (one) 17503A-01-04*	\$1,100.00
7127A OPTIONS (factory-installed at time of purchase)		
High-low limit switches on Model 7127A.	01	50.00
115 or 230 V, 50 Hz operation.	03	N/C
Left-mounted event marker.	04	35.00
Both left and right-mounted event marker.	06	70.00
Disc Integrator**.	07	585.00
Carrying handle.	11	25.00
Mounted in cabinet compatible with F & M gas chromatographs.	12	100.00

\*For 50 Hz operation on input module 17503A, also add -02. See option table for recorder 50 Hz operation.

\*\*Disc integrator and right-mounted event marker cannot be installed on same recorder.

## AUTOMATIC PREP GC

High-capacity with versatile automation  
Model 775



## PREPARATIVE GAS CHROMATOGRAPH

An all-purpose preparative gas chromatograph, the Model 775 accommodates with equal ease, both the "long-narrow" columns of  $\frac{3}{8}$ ,  $\frac{1}{2}$  or  $\frac{3}{4}$  inch OD and the new "short-wide" columns of  $2\frac{1}{2}$  and 4 inches OD. Because of this unique capability, it is equally capable of making high-capacity, high-resolution and trace component separations.

### High-capacity

When you want to collect very large volumes of a major component, the Model 775 does the job with either  $2\frac{1}{2}$  or 4-inch OD columns. Sample injections as large as 125 ml are made repeatedly and as much as a liter of the desired pure component may be collected in a single day. In the chromatogram of a turpentine separation illustrated here, the Model 775 automatically made injections of about 65 ml each every half-hour for 30 hours, until 3480 ml of the two major components ( $\alpha$  and  $\beta$ -pinene) were collected, each at a purity of better than 98%.

### High-resolution

When you want to collect only a small quantity of a hard-

to-separate component, equip your Model 775 with long-narrow columns (as much as 400 feet of  $\frac{3}{8}$  or shorter lengths of  $\frac{1}{2}$  or  $\frac{3}{4}$ -inch OD column, depending on the desired degree of resolution.) In the middle chromatogram illustrated here, the Model 775 separated a 2.0 ml sample of premium gasoline on 32 feet of  $\frac{3}{4}$ -inch column; approximately 50 milligrams of one component was collected with a purity of 97.9%, for subsequent identification by infrared spectrometry.

### Trace components

When you want to collect a trace component from a mixture, a great deal of time can be saved by using short-wide columns and a large sample size. With this technique, the trace component can be collected in an adequate quantity after only a single run. In the bottom chromatogram, a 10 ml injection of a proprietary plasticizer compound was made on 40 inches of 4-in. OD column and the impurities (small peaks at right of major peak) were separated out and collected apart from the main component.

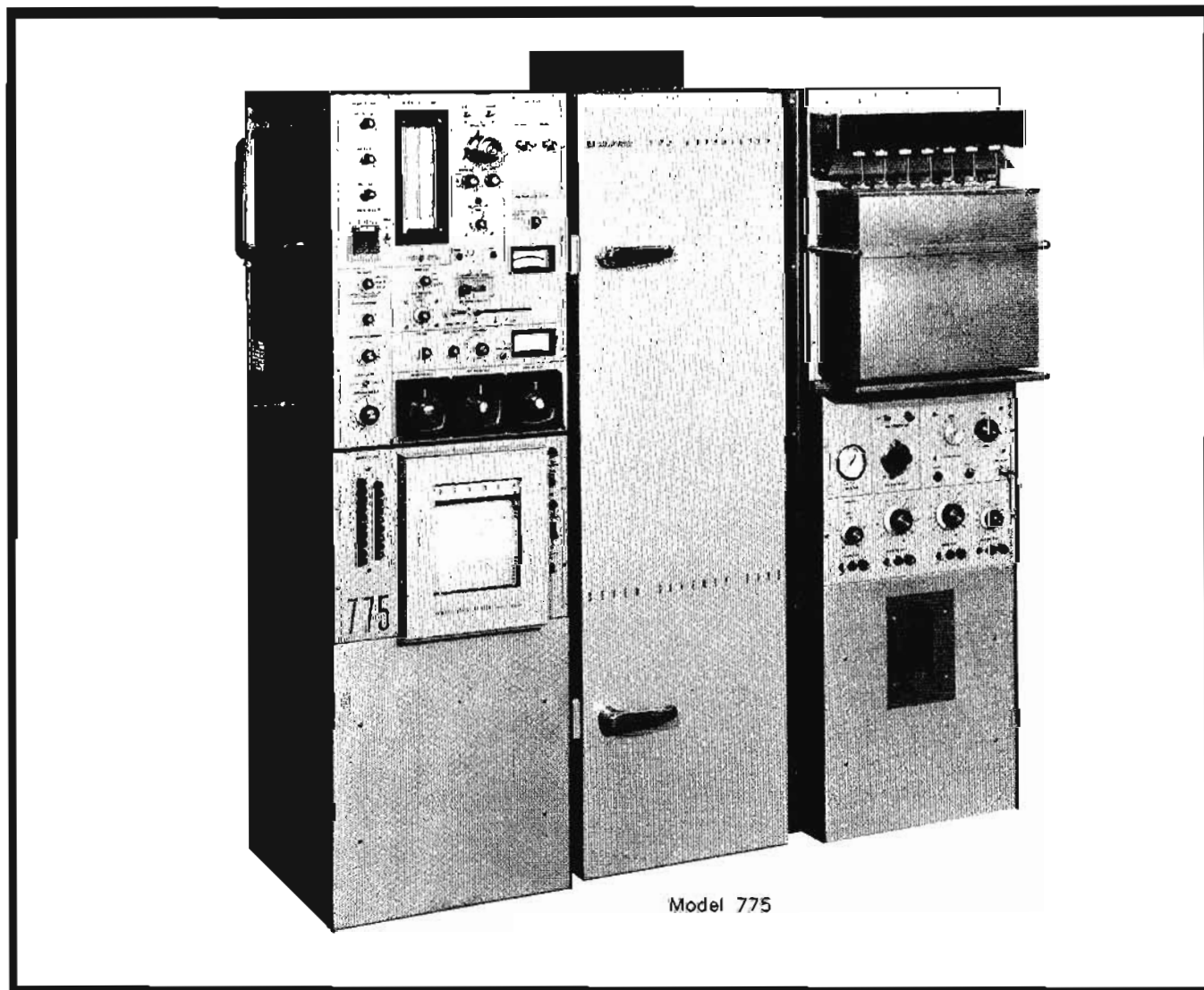

Model 775

# PREPARATIVE GAS CHROMATOGRAPH



## AUTOMATIC PREP GC

High-capacity with versatile automation  
Model 775

### Model 775 specifications

#### Columns:

**Preparative:** accepts up to 80 inches of 4" OD; proportionate lengths of 1/2", 3/8", 3/4" and 2 1/2" OD.

**Analytical:** 1/4" OD.

#### Detector:

Thermal conductivity, four filament, hot-wire; high-capacity design (no splitting required).

Integral power supply and bridge controls.

#### Temperature control:

**Controllers:** independent indication and control of injection port to 350°C, column oven to 325°C, detector oven and manifold to 350°C.

**Oven temperature programmer:** choice of 10 rates from 0.25 to 10°C/min; adjustable pre-, post-injection and upper limit time delays; programmed or isothermal, manual or automatic operation.

**Safety limit controllers:** hi-limit oven temperature cut-off prevents accidental overheating of columns; interlock prevents operation of column oven heater without fan.

#### Sample Injection:

**Automatic:** pneumatically operated time cycle injector for 0.25 to 125 ml injections.

**Manual:** septum type; for 0.25 to 125 ml injections.

**Vaporizer:** high-capacity heat sink supplies 664 calories per °C temperature drop for sample vaporization.

**Sample reservoir:** 300 ml pressurized reservoir; 1000 and 2250 ml optional.

#### Sample collection:

**Traps:** seven 50 ml glass traps in standard cooling bath; 1000 ml stainless steel traps optional.

**Component selector:** permits automatic collection of any six components from a series of up to seventeen, with venting of all others to bypass trap.

#### Flow measurement & control:

Three element type rotameter for continuous indication and control of carrier gas flow to prep and analytical columns.

#### Recorder:

Integral strip chart recorder.

#### Physical:

63" high, 62" wide, 24" deep; 875 lbs (shipping). Casters and leveling pads.

#### Electrical:

208-220 V, 60 Hz, 20 A.

Three circuit breakers.

#### Ordering No.

#### How to order General Description

#### Price

#### Complete instrument

Model 775	Automatic Preparative GC, including one 300 ml sample reservoir, seven 50 ml glass traps, 48" of 1/4" OD copper column, 80" of 3/4" OD stainless steel column and Electronic 18 recorder.	\$8800.00
-----------	---	-----------

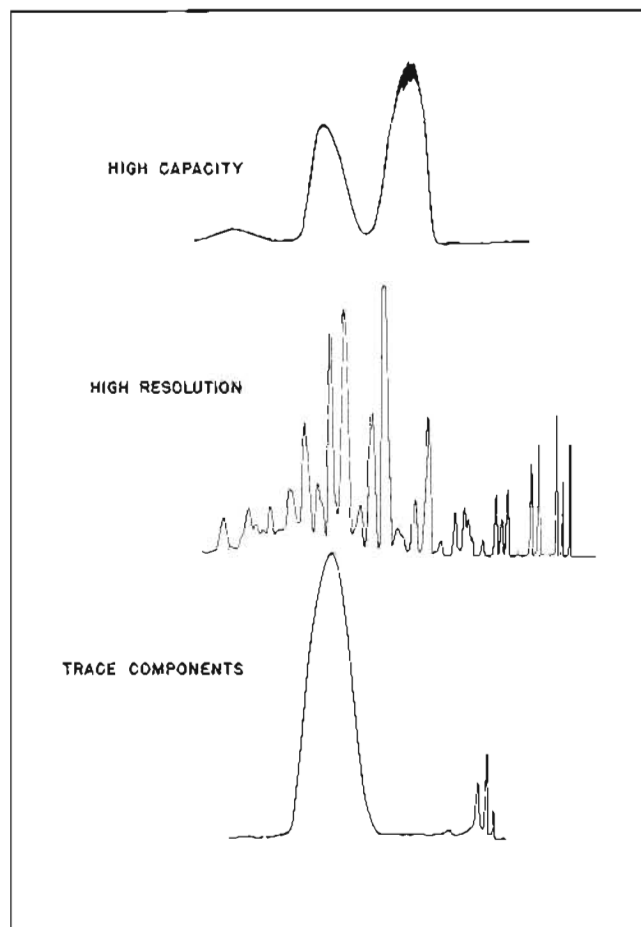

#### Optional accessories

Columns	3/8" OD aluminum; packed; 20 ft. long.	\$ 125.00
	3/4" OD stainless steel; packed; 80" long.	\$ 95.00
	2 1/2" OD stainless steel; empty; 80" long.	\$ 789.00
	4" OD stainless steel; empty; 80" long.	\$ 895.00
Packings	Complete choice (write for Columns & Accessories catalog).	
Sample Reservoirs	1000 ml; stainless steel (part No. 4-5512-2).	\$ 135.00
	2250 ml; stainless steel (part No. 4-5512-1).	\$ 200.00
Collection Traps	50 ml; glass, thermal gradient (part no. 2-3832, w/o adaptor)	\$ 44.00
	spiral; glass (part no. 2-4619, w/o adaptor)	\$ 42.00
	1000 ml; stainless steel (part No. 1-5918, with adaptor).	\$ 210.00

## MANUAL PREP GC

Economical high-capacity, manual operation  
Model 776



## PREPARATIVE GAS CHROMATOGRAPH

The Model 776 Preparative Gas Chromatograph offers an economical alternative to the Model 775, with the same true prep-scale capacity but without the automatic features. It accepts any prep column between  $\frac{3}{8}$  and 4" OD, handles up to 125 ml/injection, with a demonstrated collection efficiency of 90-98% at purity levels approaching 100%. The 776 also has an integral analytical gc capability.

### Semi-automatic sampling system

Preparative injections can be made through a pair of valves that apply carrier gas pressure to the sampling reservoir and thus inject the sample. These semi-automatic injections are visually monitored from the calibrated sampling reservoir. A manual syringe may also be used directly in the preparative injection port. A separate septum-type injection port, located adjacent to the preparative injection port, accommodates the 776's analytical gc system.

### Unique flame detector

The flame detector of the Model 776 is unique in that the hydrogen-air supply is fed to the flame, independently of column flow conditions, thus allowing better control of flame size and avoiding inadvertent back-flow of hydrogen into the oven. For normal operation with 4" columns, approximately 0.1% of the column effluent is diverted to the flame detector.

This flow is measured by a manometer and controlled by a variable splitter.

All effluent from the analytical column feeds into the flame detector.

### Unlimited oven capacity

The basic 776 oven is designed for isothermal operation but it can also be manually programmed. Its two-element, two-blower heating system yields a maximum temperature of 300°C. A solid-state controller is used along with an upper limit cut-off to control oven temperature.

Design of the 776 permits the use of multiple "Add-On" Oven Modules that are identical in capacity and operating characteristics to the basic oven, thus giving the 776 a virtually unlimited column capacity.

### Versatile collection system

A high-efficiency collection manifold has five positions each of which is equipped with a 50 ml glass spiral trap, a vent tube that protrudes above the manifold, and a gravity-seal plug. To switch collection from one trap to another is simply a matter of transferring the plug from one trap outlet to another.

The supporting tray for the traps and cooling bath is vertically adjustable for convenience.

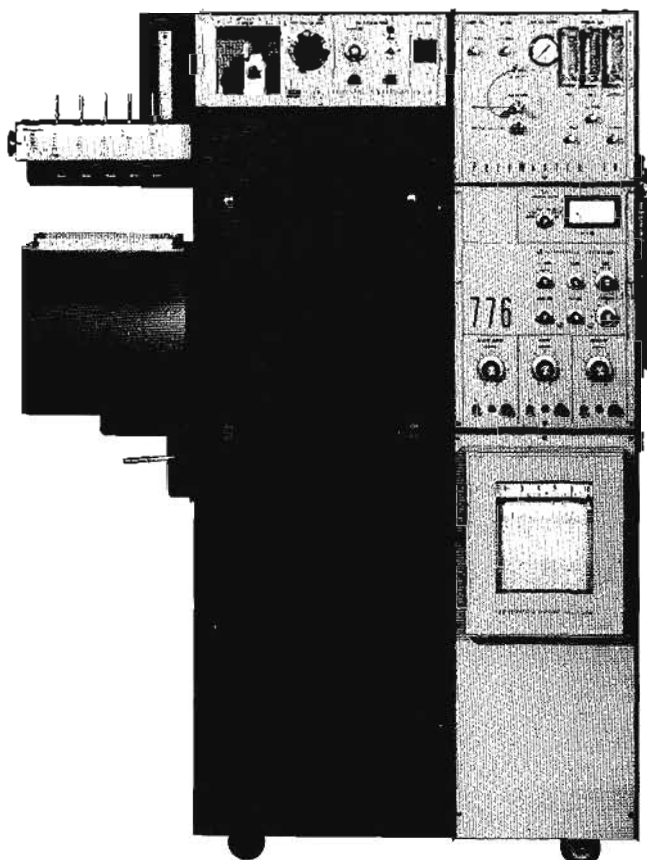

Model 776

# PREPARATIVE GAS CHROMATOGRAPH



## MANUAL PREP GC

Economical high capacity manual operation

Model 776

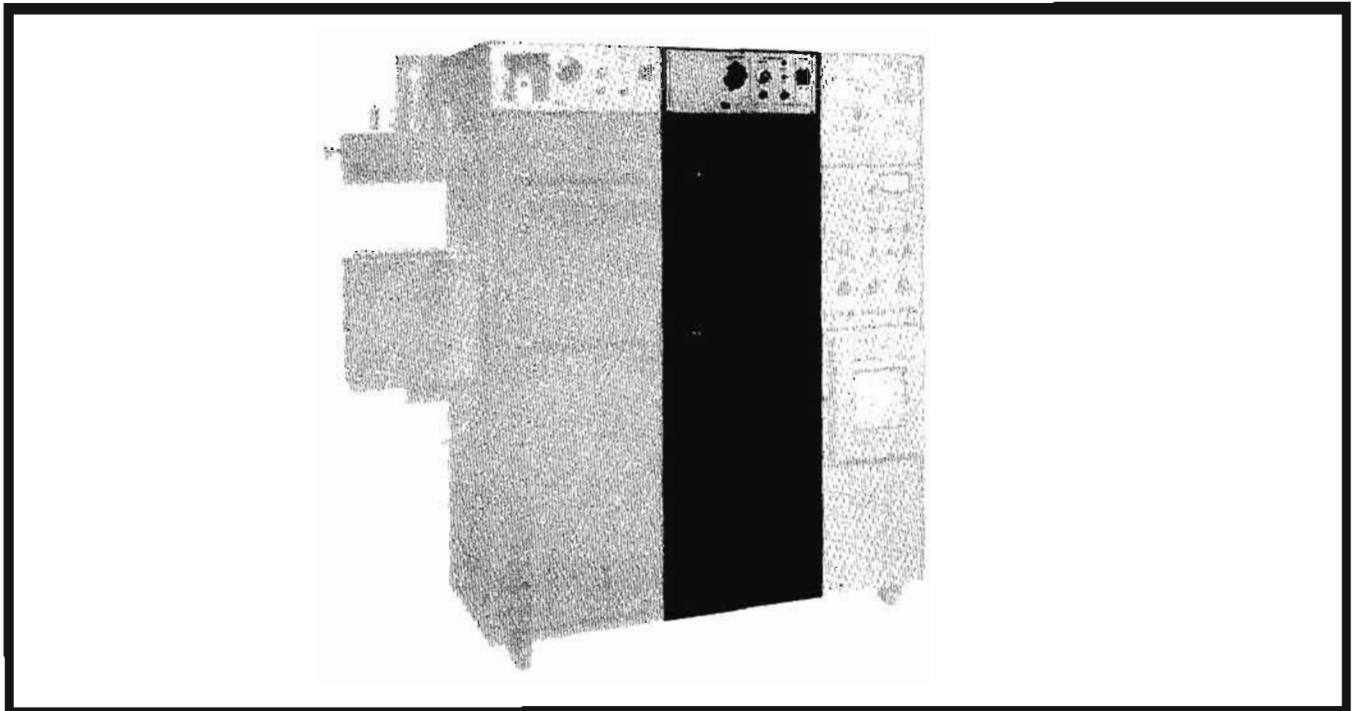

### Model 776 Specifications

#### Columns

**Preparative:** accepts up to 80 inches of 4" OD; proportionate lengths of 1/2", 3/8", 3/4" and 2 1/2" OD.

**Analytical:** 1/4" OD.

#### Detector

Unique flame ionization detector design avoids back flow of flame gas, permits nitrogen as carrier gas. Integral electrometer.

#### Temperature control

**Controllers:** independent indication and control of injection port and manifold to 350°C, and column oven to 300°C.

**Safety limit controller:** hi-limit oven temperature cut-off prevents accidental overheating of columns; interlock prevents operation of column oven heater without fan.

#### Sample Injection

**Semi-automatic:** gas-operated injector for 1.00 to 125 ml injections.

**Manual:** septum type.

**Vaporizer:** high-capacity heat sink supplies 664 calories per °C temperature drop for sample vaporization.

**Sample reservoir:** 75 ml pressurized reservoir.

#### Sample collection

**Traps:** five 50 ml glass traps and cooling bath; manually selected bypass.

#### Recorder

Optional strip chart recorder.

#### Flow measurement

**Rotameter:** for continuous indication of carrier gas flows; needle valves for control.

**Manometer:** for measurement of detector gas flows.

#### Physical

63" high, 48" wide, 23" deep; 425 lbs (shipping). Casters and leveling pads.

#### Electrical

115-125 V, 60 Hz, 20 A.

Three circuit breakers.

### How to order

Ordering No.	General Description	Price
<b>Complete Instrument</b>		
Model 776	Manual Preparative GC, including 75 ml sample reservoir, five 50 ml glass spiral traps and cooling bath, 80" of 3/4" OD prep column, and 48" of 1/4" OD analytical column.	\$3500.00
<b>Options</b>		
01	50 Hz operation	
02	Honeywell ElectroniK 18 recorder with 6" chart.	\$ 615.00
03	Model 240 temperature programmer.	\$ 645.00
04	Add-on Oven (part number 5810A) identical in capacity and function to basic oven (15A; 115 V).	\$1200.00
<b>Columns, Packings, Traps</b>		
Columns	3/8" OD aluminum; packed; 20 ft. long.	\$ 125.00
	3/4" OD stainless steel; packed; 80" long.	\$ 95.00
	2 1/2" OD stainless steel; empty; 80" long.	\$ 789.00
	4" OD stainless steel; empty; 80" long.	\$ 895.00
Packings	Complete choice (write for Columns & Accessories Catalog).	
Collection Traps	50 ml; glass, thermal gradient (part no. 2-3832, w/o adaptor).	\$ 44.00
	Spiral; glass (part no. 2-4619, w/o adaptor).	\$ 42.00
	1000 ml; stainless steel (part no. 1-5918, with adaptor).	\$ 210.00

# MICROWAVE SPECTROMETER

Frequency and quantitative measurements  
Model 8400B



## SPECIALIZED ANALYZER

Four Microwave Spectrometers are available covering the frequency bands between 8 and 40 GHz. The basic spectrometer consists of a phase-locked microwave source capable of being swept over any part or all of a frequency band, six foot Stark Cell, modulation and detection system, direct frequency read-out and marking system, power leveling instrumentation, analog display on meter, recorder and oscilloscope, all necessary couplers and attenuators, and completely assembled in consoles. The price includes on-site installation, instruction of operating personnel and a full one year warranty on overall spectrometer performance.

Seven frequency conversion kits are available to convert any one of the four 8400B Microwave Spectrometers to another frequency band. The 8450A Frequency Conversion Kit includes the RF Unit, instruments for the leveling loop, necessary waveguide instruments such as attenuators and couplers, isolators, low pass filters and appropriate detector or adapter.

Four 8450A Signal Calibrators are available covering the frequency bands between 8 and 40 GHz. The price includes two directional couplers, waveguide attenuators, modulator, phase-shifter, factory assembly and calibration. The spectrometer is available for mounting on a bench or on a wall. For those people who already have their own microwave spectrometer, subassemblies such as phase-locked sources, modulation and detection systems and Stark Cells are available. For more information on specifications, applications, price and delivery, please contact your local Hewlett-Packard Field Office or the Microwave Division, 1501 Page Mill Road, Palo Alto, California.

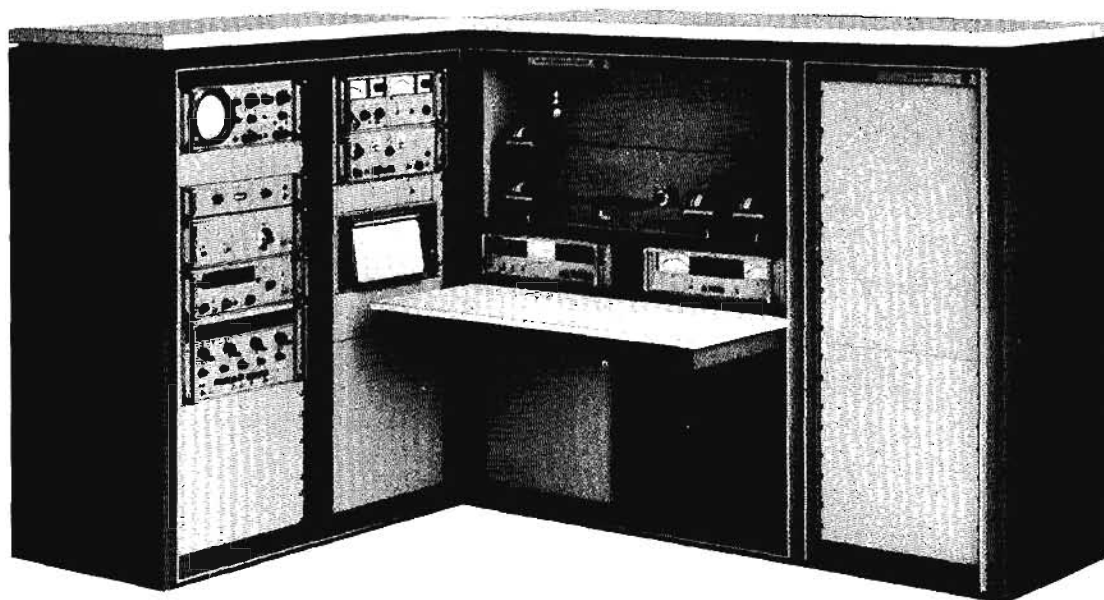
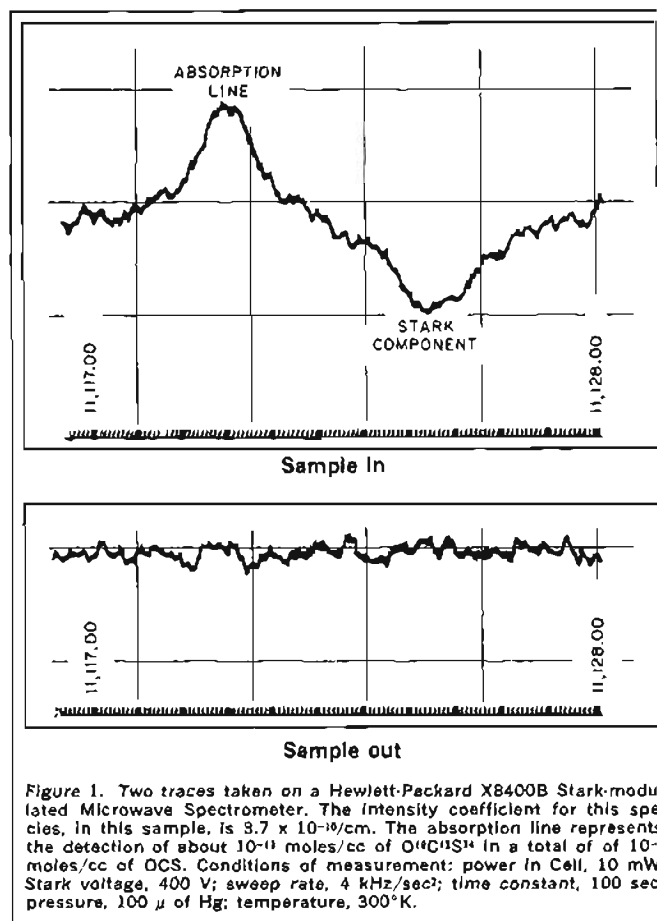

R8400B (26.5 to 40 GHz) with R8450A Signal Calibrator



## SPECIALIZED ANALYZER



## CHN ANALYZER

Simultaneous microdetermination of C, H and N  
Model 185

The classical Pregl and Dumas methods for the microdetermination of carbon, hydrogen and nitrogen are slow, tedious and expensive. With the Model 185 Carbon Hydrogen Nitrogen Analyzer, the microchemist now has at his disposal an equally accurate and reliable alternate method that is 4 to 8 times faster — the complete 185 analysis takes less than 10 minutes.

In addition to being faster than the conventional methods, the 185 also requires a much smaller laboratory investment because it enables a technician with only a minimum of microanalytical training and experience to obtain reliable results under normal laboratory conditions.

### Complete CHN analysis in 10 minutes

A second-generation performance-proved instrument for the simultaneous microdetermination of carbon, hydrogen, and nitrogen in organic materials, the Model 185 performs a complete elemental analysis in 10 minutes. There are five separate reasons for the Model 185's exceptional speed advantage over the 45 to 80 minutes generally required by the combined Pregl-Dumas procedures:

- (1) *only one sample is required* rather than two for Pregl-Dumas,
- (2) *only one weighing is needed*, rather than the multiple "weigh-in, weigh-out" procedures of the classical methods;
- (3) *analysis computation is greatly simplified*, normally requiring only a measurement of peak height on the recorder chart. The reason is that the standard Model 185 is equipped with a ratio recording system that links the sample balance and the recorder. The result is that samples of the composition give the same peak height regardless of differences in sample weight. Sample weight need not be recorded therefore and the computation is reduced to a simple multiplication;
- (4) *analysis can be continuous* because one sample can be weighed while the combustion products of the previous sample are being chromatographed; and
- (5) *the extensive automation* of the Model 185 greatly simplifies all other aspects of the microanalysis.

### Micro laboratory environment not required

Microanalysis with a Model 185 requires a single weighing of a small (less than 1 mg) sample directly into a light aluminum boat on a low-capacity, environment-insensitive microbalance under normal laboratory conditions. Since absorption tubes are neither required nor used, the special laboratory environment that is necessary for the conventional microanalytical weighing is not needed.

The 185 offers still another economy in the micro lab: operator training. To train a technician who is generally familiar with conventional microanalytical laboratory routine takes only a short time because the 185 method is much more simple than the conventional procedure and particularly because it eliminates the weighing of heavy absorption tubes on a high-capacity microbalance, a technician with only limited microanalytical experience can be trained to obtain reliable results in a minimum of time.

### Instrument design features

The Model 185 CHN Analyzer incorporates a number of important design features that are unique among instruments for elemental analysis, the result of Hewlett-Packard's experience in the field which surpasses that of any other manufacturer.

**Two-stage furnace for optimum oxidation and reduction:** the Model 185 uses a two-stage furnace for sample combustion:

- (1) an oxidation furnace, automatically controlled at any temperature between 750 and 1050°C as selected by the analyst for the best oxidation conditions for the sample at hand;
- (2) a reduction furnace, automatically held at 400 to 600°C to provide complete reduction of all nitrogen oxides and excess oxygen, thus ensuring nitrogen determinations that are reliable within the allowable error of  $\pm 0.3\%$ .

**Automatically timed combustion cycle:** the peak height response obtained during the chromatography of the oxidation products is dependent upon the time the sample is confined in the combustion

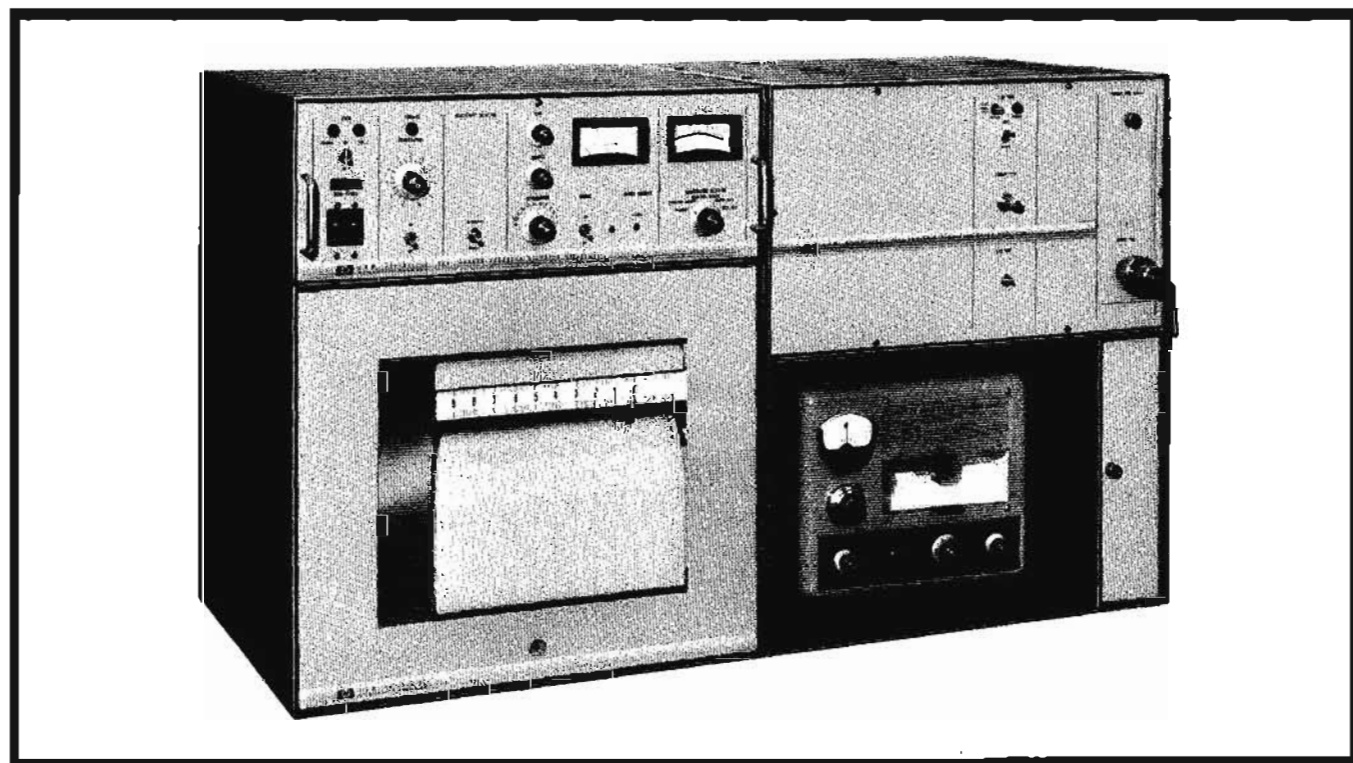

# CHN ANALYZER

Simultaneous microdetermination of C, H and N  
Model 185



## SPECIALIZED ANALYZER

chamber. In the 185, the combustion period is automatically and precisely controlled to eliminate analytical error from this source. A flow diversion switch and timer are used for this purpose. In the "Timed" position, carrier gas flows through the furnace until a "Start" button is pushed. When timer is started, carrier gas bypasses the furnace for a precisely timed 20-second period, at end of which it is automatically re-directed through the furnace, sweeping combustion products into the gas chromatograph.

In the "Manual" position, carrier gas bypasses the furnace. Pilot lights indicate whether carrier gas flow is in "bypass" or "through furnace" (as shown in diagram).

**Two-zone oven for consistent GC analysis:** the 185's column oven consists of an outer shell and an inner column oven, each equipped with separate and independent temperature control. The outer shell maintains an ambient temperature near that of the oven and keeps column temperature stable. Peak height thus responds to sample composition only and the baseline is stable.

**Single-column single-detector GC system:** improved column technology led to the single-column, single-detector design of the 185. All three combustion products — CO<sub>2</sub>, H<sub>2</sub>O, N<sub>2</sub> — are separated in a single pass resulting in a three-peak chromatogram, one peak for each of the combustion products.

**Automatic sensitivity selector:** an automatic sensitivity selector keeps all three peaks on scale for all types of samples, and allows direct peak height readout of the analytical trace. This feature releases the operator from having to manually attenuate the CO<sub>2</sub> peak on each analytical run, thus providing unattended operation from sample injection to completion of run.

### Specifications

**Analysis time:** 10 minutes total.

**Accuracy:** comparable to Pregl and Dumas methods; within 0.3% allowable error for all three elements.

**Sample range:** any solid or liquid material that burns completely at 1050°C or less, including those that contain O, S, P, Cl, Br, I, F, As, Sb, and Sn.

**Furnace:** two-stage type with oxidation furnace and reduction furnace, each independently temperature-controlled.

**Oven:** two-zone type with inner oven and outer shell, each independently temperature-controlled.

**Temperature control:**

1. Oxidation furnace: variable power transformer, adjustable to 1050°C.
2. Reduction furnace: variable voltage transformer, adjustable 400 to 600°C.
3. Oven: thermostat controller, adjustable ambient to 150°C.
4. Shell: thermostat controller, adjustable ambient to 150°C.

**Temperature readout:** pyrometer graduated 0-1200°C and five-position selector switch for readout of 4 positions noted above plus ambient.

**Detector:** four-filament thermal conductivity type equipped with current adjustment, bridge balance and output attenuation controls.

**Carrier gas:** automatically timed bypass control; shutoff control; pressure regulator.

**Balance:** Cahn Ratio Electrobalance.

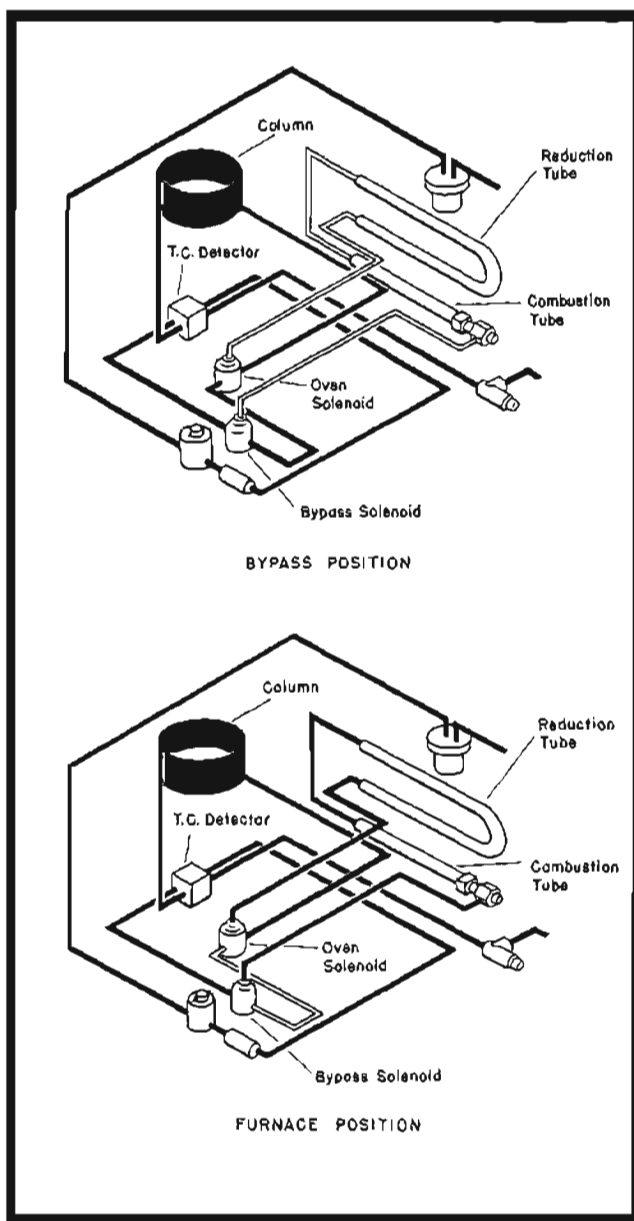

**Recorder:** Honeywell ElectroniK 16 equipped for operation with automatic sensitivity selector and Ratio Electrobalance.

**Weight:** 316 lbs overall.

### How to order

Ordering No.	Description	Price
185	Model 185, Honeywell ElectroniK 16 Strip Chart Recorder and Cahn Ratio Electrobalance	\$6000.00
19046A	F & M Gas Purifier	\$ 275.00
(Regulator Kit)	F & M Carrier Gas cylinder regulator kit (two-stage pressure regulator, 6 feet of ¼ in. O.D. copper tubing with appropriate fittings). Specify carrier gas supplier or CGA No. of cylinder outlet	\$ 50.00

## MOLECULAR WEIGHT DETERMINATION



## VAPOR PRESSURE OSMOMETER

Fast number-average molecular weights  
Model 302

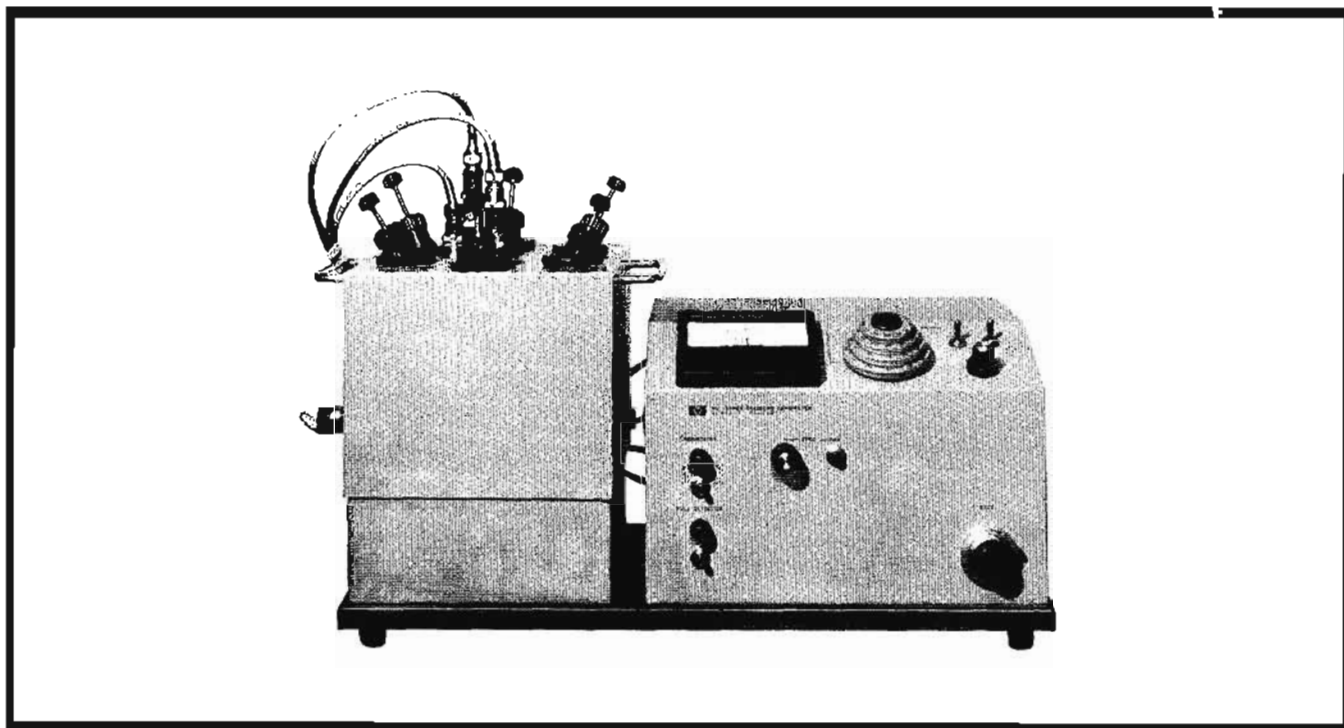

The Model 302 Vapor Pressure Osmometer measures the osmotic concentration of a solution, operating on the principle of vapor pressure lowering. From this data, number-average molecular weights of solute species in solution are determined precisely.

The Model 302 VPO is designed for molecular weight materials in the range of 100 to 25,000 and are effective for both natural and synthetic polymer measurements. It can be operated at 25°, 37°, 50°, 65°, 100°, or 130°C and can operate successfully with sample sizes as small as 10 microliters. It is capable of measuring temperature differential between sample and solvent drops to better than 0.0001°C.

### Principles of operation

In the VPO, two bead thermistors are suspended in a precisely thermostated chamber saturated with solvent vapor. The beads, which undergo a large change in resistance ( $\Delta R$ ) for a relatively small change in temperature, form two legs of a Wheatstone bridge.

When a drop of solvent is placed on the reference thermistor and a drop of solution placed on the measuring thermistor, solvent condenses on the solution drop because of the lower vapor pressure of the solution. This condensation warms the measuring thermistor, producing a difference in temperature and, as a result, a relatively large bridge imbalance  $\Delta R$  (approximately 100 ohms per mole for benzene).

Since  $\Delta R$  is a relative quantity dependent on both the solvent and the probe, the VPO must be calibrated with a known molecular weight solute for each solvent and probe used. Its value is determined at several concentrations and plotted. The curve is then extrapolated to infinite dilution to determine the molar constant ( $K$ ). Once established, this constant does not vary for the particular probe and solvent used and only a

single calibration is needed. The molecular weight of the unknown is then calculated as follows:

$$MW = \frac{K}{\left(\frac{\Delta R}{c}\right)_{c \rightarrow 0}}$$

where  $c$  = grams/liter

### Rapid measurement

The VPO's syringe method of introducing sample drops into chamber permits readings on a series of samples at 2 to 3 minute intervals. A single reading may be taken in 2 minutes for most organic solvent-solute systems, in 4 to 5 minutes with aqueous solutions. Usually, some 60 to 80 measurements can be made each 8-hour day.

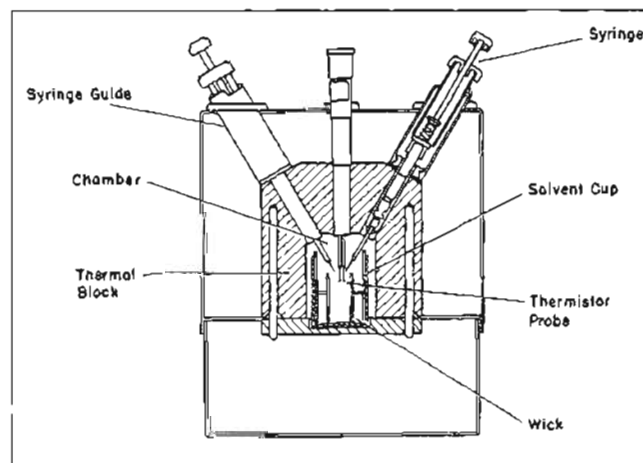

# VAPOR PRESSURE OSMOMETER

Fast number-average molecular weights  
Model 302



## MOLECULAR WEIGHT DETERMINATION

### Dependable results

The VPO is capable of operating on an around-the-clock basis, providing 1% accuracy for low molecular weight compounds and useful data for molecular weights to 25,000. Reproducibility is better than 1% except at very low readings. The following table gives accuracy of the instrument for representative determinations:

Sample Type	Formula MW	VPO MW	Error
Benzene calibrated with benzil			
1. Anthracene	178.2	177.0	-0.7%
2. Sucrose Octoacetate	678.6	675.0	-0.5%
Water calibrated with dextrose			
1. dl-alanine	89.1	89.7	+0.7%
2. Raffinose	594.5	586.0	-1.3%

### Precision

The VPO's bridge circuitry measures 1.00 ohm to the nearest 0.01 ohm (1% precision).

For a typical organic solvent at 37°C operating temperature, the Vapor Pressure Osmometer will show a bridge imbalance of 400 ohms per mole of solute. Thus a 0.01 molar solution will give an imbalance of 4.0 ohms (neglecting concentration effects) which can be read to 1% precision. A molecular weight polymer of 20,000, assuming a 2% weight concentration solubility, would give a  $\Delta R$  of 0.40 ohm which can be read to  $\pm 0.01$  ohm, a precision of 2½%.

For aqueous solutions, sensitivity is lower due to the high heat of vaporization.  $\Delta R$  for water is about 55 ohms per mole. A 3% weight concentration would give 1% precision for molecular weights up to 700 and 4.3% precision up to 3500.

The final accuracy of a measurement is dependent on several factors unrelated to instrument precision, such as the extrapolation, interactions, purity, and concentration effects.

### Temperature range

Unlike the cryoscopic and ebulliometric methods, VPO determinations are made without changing the physical state of the solution. Model 302 may be ordered with thermostat and thermistor probe set for any of the following temperatures: 25°, 37°, 50°, 65°, 100° or 130°C. Intermediate temperatures available on request. Chamber temperature control to within  $\pm 0.001^\circ\text{C}$ , is provided.

### Choice of solvents

Model 302 instruments are successfully used with many different solvents, a few of which are benzene, cyclohexane, carbon tetrachloride, tetrahydrofuran, ethyl acetate, acetone, pentane, toluene, ethanol, dimethylformamide, methanol, methyl ethyl ketone, isopropanol, solvent blends, and water.

### Convenience

The Vapor Pressure Osmometer requires only 10½" x 23" of bench-top space and weighs only 46 pounds. The unique syringe sample introduction system, simple bridge controls, and durable design allow the instrument to be operated routinely. The electronic section consists of three plug-in sub-chassis for ease of servicing.

### Typical applications

Bio-Medical Serum and Urine Osmolalities  
Osmotic Coefficients  
Proteins  
Sugars  
Lipids  
Chemical Monomers  
Hydrocarbons  
Prepolymers  
Polyolefins  
Polyamides  
Cellulosics  
Elastomers  
Petrochemicals  
Silicones  
Waxes

### How to order

Ordering No.	Description	Price
302	Vapor Pressure Osmometer Includes probe and thermostat for either aqueous* or non-aqueous operation at one temperature. Specify one temperature (25°, 37°, 50°, 65°, 100° or 130°C). Specify aqueous* or or nonequeous operation. Requires additional aqueous or non-aqueous probe and thermostat for each additional temperature specified.	\$2800.00 add 200.00

\*Aqueous operation not available at 100° or 130°C.

### Options

01	230 V, 50-60 Hz operation.	add 75.00
02	Self draining solvent cup.	add 66.00
03	High range decade	add 110.00

## MOLECULAR WEIGHT DETERMINATION



## MEMBRANE OSMOMETER

Automated determination of  $\bar{M}_n$   
Series 500

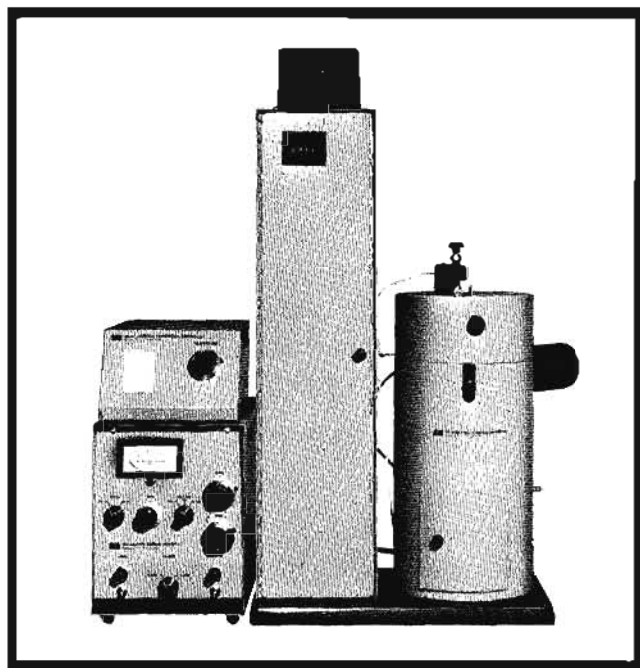

Series 500 Membrane Osmometers are automated instruments for the precise and speedy determination of the number-average molecular weight of natural and synthetic polymers in the range 10,000 to 1,000,000. They operate with aqueous as well as organic solvents, at temperatures between 5°C and 130°C. The 500 measures osmotic pressure with a repeat accuracy of  $\pm 0.02$  cm of solvent in a range of 20.00 . . . on samples as small as 1 ml.

Based on the dynamic method of measuring osmotic pressure, the 500 reaches equilibrium when no more than  $10^{-9}$  liter of solvent has moved into the membrane.

Individual readings are frequently completed within 10 minutes after the sample has been introduced . . . and a full concentration series, within an hour.

Sample introduction and flushing are speeded by a valved siphon system. A single membrane is used, thus there are no membrane matching problems. Dynamic osmometry eliminates dilution of the solution and the consequent need for washing out the solvent reservoir after each determination.

Once the sample has been introduced into the 500, the rest is fully automatic. Its sensitive optical-servo system automatically adjusts the height of the solvent reservoir until equilibrium is reached . . . reading out the osmotic pressure directly on the digital counter or on the recorder chart.

### How it operates

Sample solution is introduced above and pure solvent below the membrane of the 500. Since the membrane is semi-permeable (solvent molecules may pass but not sample molecules), solvent tends to pass through it in proportion to the force of the osmotic pressure of the solution. But the 500 is a dynamic osmometer which detects and opposes this force through an optical servo-mechanism that reduces the hydrostatic head on the solvent side of the membrane until it exactly equals the osmotic pressure of the solution and thus prevents solvent flow. The system is so sensitive and fast that less than  $10^{-9}$  liter of solvent flows into the membrane before equilibrium is established.

Here's how the servo system works. The solvent reservoir is mounted on a motor-driven screw elevator and connected to the solvent side of the membrane through a capillary in which there is a small air bubble. A light source is focused on the bubble and reflected to a companion photocell. Any flow of solvent through the capillary tends to move the air bubble and this motion is immediately detected by a change of light intensity on the photocell. The amplified output of the photocell activates a servo motor which drives the screw elevator and adjusts the height of the solvent reservoir to return the bubble to its previous position. As a result, the hydrostatic head of the solvent is exactly opposed to the osmotic pressure of the solution.

At all times during the process, the hydrostatic head on the solvent side of the membrane is indicated on the 500's digital counter. At equilibrium, which is frequently reached within 10 minutes, the counter reading is equivalent to the osmotic pressure of the solution.

### Advantages of the 500

The Series 500 Membrane Osmometer is literally the fastest way to determine number-average molecular weight  $\bar{M}_n$ . An individual determination is frequently completed within 10 minutes after the sample has been introduced; some samples take as little as three minutes while even the most difficult seldom require as much as an hour. As a result, a full concentration series for determinations is frequently completed within an hour . . . as compared to several hours for other instrumental techniques, and several days for manual static osmometry.

The 500 derives still another speed advantage from its dynamic osmometry principle. There is no net flow of solvent across the membrane and therefore no dilution of the sample. This speeds calculations as well as instrument prep time.

The 500 is capable of precise number-average molecular weight determinations between 10,000 and 1,000,000. Commercially available membranes even permit operation below 10,000 in many cases. The instrument is also capable of osmotic and oncotic pressure measurements up to 20 cm of hydrostatic head pressure . . . of measuring activity coefficients and interactions . . . and of testing membranes.

Because its sample chamber volume is less than 0.4 ml, the 500 can make useful measurements with as little as 0.5 ml of sample. Standard procedure, for best accuracy, calls for 1 ml of sample including two rinses. For greatest convenience, when sample solution is plentiful, a 5 ml sample is used.

The 500 continuously displays osmotic pressure on an integral 4-digit counter with a readability of 0.01 cm of solvent head. The instrument also incorporates a recorder output with range and zero adjustments.

### Applications

The most frequent application of Series 500 Membrane Osmometers is to determine the number-average molecular weight  $\bar{M}_n$  of soluble macro molecules. There are two good reasons for this:

1.  $\bar{M}_n$  is the most useful of the molecular weight calculations because it lies near the peak of the molecular weight distribution curve;  $\bar{M}_n$  therefore represents the most probable molecular weight of the polymer. Furthermore, the breadth of the distribution curve can be approximated from the relationship of

$\frac{\bar{M}_n}{\bar{M}_w}$  and this relationship is useful in predicting the physical

# MEMBRANE OSMOMETER

Automated determination of  $\bar{M}_n$   
Series 500



## MOLECULAR WEIGHT DETERMINATION

properties of the polymer.

2. The Series 500 measures  $\bar{M}_n$  faster and more easily than any other method. Procedures are quite simple: three or four very dilute concentrations of the polymer solution are prepared and their osmotic pressure ( $\pi$ ) is measured in the 500... automatically. Reduced osmotic pressure ( $\pi/C$ ) is calculated and plotted against concentration ( $C$ ). Finally, the value of  $\pi/C$  at zero concentration is extrapolated from the plot and the final calculation is made:

$$\bar{M}_n = \frac{RT}{(\pi/C)_{C \rightarrow 0}}$$

### Molecular conformation studies

Measurement of osmotic pressure can also yield useful information about polymer-solvent interactions and, through this, insight into molecular conformation and chain configuration.

Here's how. Polymer-solvent interactions result in non-zero slopes when reduced osmotic pressure ( $\pi/C$ ) is plotted against concentration ( $C$ ). Measurement of the slope gives a quantitative measure of the energy of interaction, usually expressed as the second virial coefficient as follows:

$$\frac{\pi}{C} = RT \left[ \frac{1}{\bar{M}_n} + A_2 C \right]$$

where  $A_2$  = second virial coefficient

R = gas constant

T = absolute temperature

The second virial coefficient itself measures deviations from ideal solution behavior. It can be approximately related to the excluded volume ( $\mu$ ) of the polymer molecule as follows:

$$A_2 = \frac{N\mu}{2M^2}$$

where N = Avogadro's number

M = molecular weight

### Specifications

**Sample volume:** 0.5 ml min.; 1.0 ml standard.

**Sample concentration:**

Molecular weight	Minimum conc.		Maximum conc.	
	g/l	moles/l	g/l	moles/l
10,000	0.05	$5 \times 10^{-6}$	5	$5 \times 10^{-4}$
100,000	0.5	$5 \times 10^{-6}$	50	$5 \times 10^{-4}$
1,000,000	5.0	$5 \times 10^{-6}$	50	$5 \times 10^{-5}$

**Sample transport:** siphon type, with control valve.

**Membrane:** 2 cm<sup>2</sup> active area; 42 mm diameter for aqueous, 47 mm for non-aqueous.

**Materials in contact with sample-solvent:** stainless steel, Teflon and Pyrex.

**Solvent type:** aqueous or non-aqueous, as specified.

**Temperature range:** Model 501, 25° to 65°C; Model 502, 25° to 130°C; Model 503, 5° to 65°C (includes thermoelectric cooler).

**Temperature control:** standard, thermostat pre-set for control at fixed temperature (5°, 25°, 37°, 50°, 65°, 100°, 110°, 130°C, as specified).

Optional—variable temperature controller for operation at any temperature within overall range of instrument.

**Safety cut-off:** separate thermostat cuts off power to heater in case of excessive heat.

**Observation systems:** telescope for viewing sample stack; port for viewing capillary.

### Elevator

**Servo system:** optical servo system automatically adjusts elevator to balance hydrostatic head of solvent against osmotic pressure of solution.

**Hydrostatic head readout:** type, four-digit counter; range, 20 cm nominal; readability, 0.01 cm; repeatability,  $\pm 0.02$  cm.

### Electronics

**Servo controls:** selector switches and milliammeter.

**Recorder output:** 10 mV standard; 1 mV optional. Range and zero controls standard (max. sensitivity gives full-scale response for 1 cm of hydrostatic head).

**Power consumption:** 115 V, 50 or 60 Hz, 60 watts.

**Recorder:** (optional), full transistorized, 10-inch pen travel, 1/2-second pen speed, 0.2% accuracy, 0.1% linearity; 4-speed chart drive (1 1/2, 3, 6 and 12 in./hr.).

### Dimensions

**Elevator and sample chamber:** 34 1/2" high (87.5 cm), 21 1/2" wide (54.6 cm), 14 1/2" deep (36.8 cm); 76 lbs net (34.5 kg).

**Electronics module:** 11 3/4" high (29.8 cm), 9" wide (22.9 cm), 21" deep (53.2 cm); 35 lbs net (15.9 kg) for 115 V operation, 43 lbs (19.6 kg) for 230 V operation.

**Thermoelectric cooler:** (Model 503 only), 14 1/2" high (36.8 cm), 8 1/8" wide (20.6 cm), 5 1/4" deep (13.3 cm).

Ordering No.	How to order Description	Price
501	Membrane osmometer for non-aqueous operation at 25° to 65°C; 10 mV recorder output; 115 V, 60 Hz	\$4375.00
502	Membrane osmometer for non-aqueous operation at 25° to 130°C; 10 mV recorder output; 115 V, 60 Hz	5125.00
503	Membrane osmometer for non-aqueous operation at 5° to 65°C; 10 mV recorder output; 115 V, 60 Hz	5700.00
<b>Options (factory-installed)</b>		
01	For aqueous operation	n/c
02	Thermostat for operation at 5°C (Model 503 only)	60.00
03	Thermostat for operation at 25°C	60.00
04	Thermostat for operation at 37°C	60.00
05	Thermostat for operation at 50°C	60.00
06	Thermostat for operation at 65°C	60.00
07	Thermostat for operation at 100°C (Model 502 only)	60.00
08	Thermostat for operation at 110°C (Model 502 only)	60.00
09	Thermostat for operation at 130°C (Model 502 only)	60.00
10	Variable Temperature Controller	375.00
11	1 mV recorder output	n/c
20	50 Hz operation (115 V)	n/c
21	50 Hz operation (230 V)	40.00

### Recorder

H02-7127A Moseley strip chart recorder with 17504-80060 plug-in 10 mV input module, 10-inch calibrated chart, 0.2% accuracy, four-speed chart travel; 115 V, 50 or 60 Hz 1050.00

## MOLECULAR WEIGHT DETERMINATION



## AUTO-VISCOMETER

Automatic programming, recording of efflux time  
Models 5901B, 5910A, and 5903A

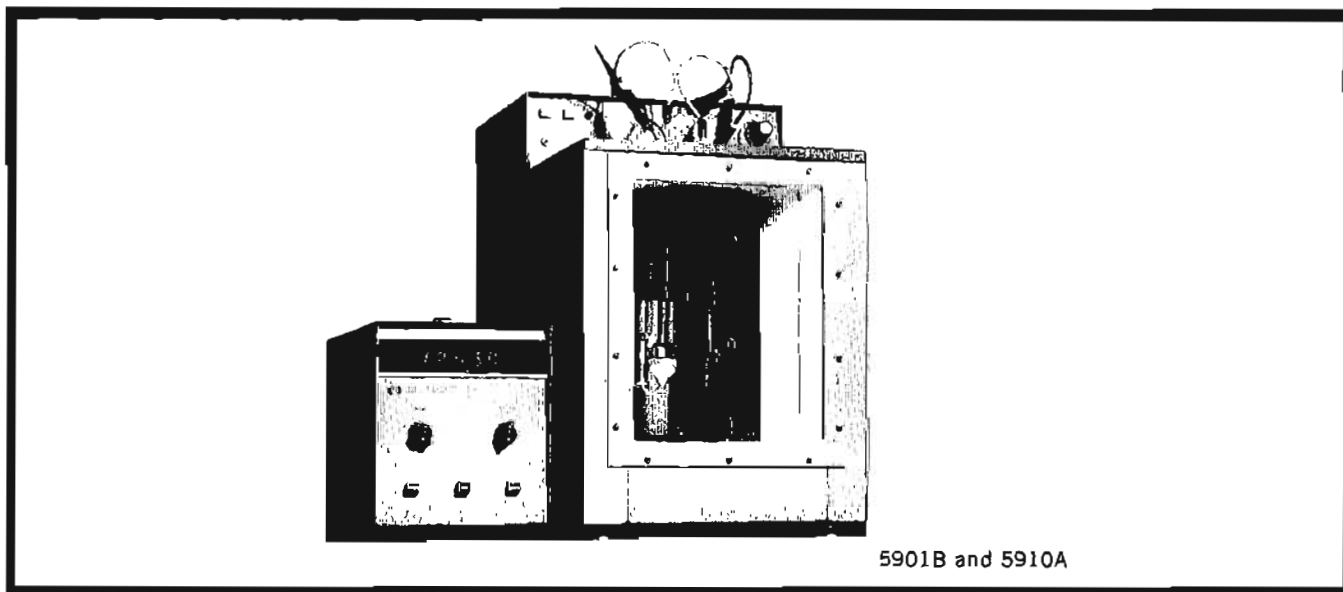

5901B and 5910A

Viscometry begins with the measurement of efflux time, which is a characteristic flow time of a liquid and corresponds to its viscosity. Therefore, highest accuracy in determining efflux times yields highest accuracy in final calculations—whether for intrinsic viscosity, kinematic viscosity, or for molecular weight.

The three instruments described here—in combination—provide extremely high accuracy and reliability in measuring efflux times. Using all three—the Auto-Viscometer, the Constant Temperature Bath, and the Programmer—you can expect:

- 10 times better accuracy than stopwatch techniques.
- Uniform temperatures for viscometers to within 0.005°C up to 75°C (within 0.01° up to 150°C).
- Unlimited and automatic repeat measurements on any given viscometer.
- Automatic sequences for all four viscometers in the system with up to 10 repeat measurements per viscometer.
- A permanent record of all efflux times measured.

Individual functions of these instruments are described as follows:

### 5901B Auto-Viscometer

Heart of the whole viscometer system is the improved version of the Auto-Viscometer, which employs a new external pumping system and a new internal pressure regulating system. This allows the use of inert gas (in place of air) as the pressure pumping medium. Inert gas is sometimes preferable to avoid oxidation of sensitive sample liquids. Four detector sets come with the unit. Each set consists of an upper and lower photocell detector for detecting meniscus movement. These detectors will fit most glass capillary viscometers.

Automatic influsing and timing eliminates error between operators due to differences in techniques and human fatigue. The bright neon-Nixie® display provides a digital readout that can be held for observation until released by the operator. A switch, selecting one of four sets of detectors, allows continuous operation. While one viscometer is running, another can be pre-warmed and others cleaned and loaded.

The Auto-Viscometer measures efflux time in glass capillary viscometers with a transistorized electronic counter using a quartz crystal oscillator as a time base reference. This approach not only makes viscosity measurements more efficient, but produces results at least 10 times more accurate than stopwatch techniques. The electronic counter measures efflux time automatically through use of photocell detectors mounted at upper and lower reference points on the glass viscometer.\* Positioning screws are provided for spacing adjustments between upper and lower reference points. Each detector consists of a self-contained, miniature light source and photocell in a compact submersible unit. "On and Off" triggering of the time interval counter occurs when the meniscus of the solution drops past the detectors; the time is read on the Nixie® display. This reading remains until intentionally erased by the operator. After the operator records the efflux time, he can either repeat the run or switch to another channel for a new measurement.

\* Glass Viscometers: Hewlett-Packard does not sell glassware but recommends the standard Ubbelohde-Dilution (suspended level) and the Ubbelohde Semi-Micro Viscometers described in ASTM D445 and DIP 71, appendices C and M. These types are convenient to use and are compatible with the 5910A Constant Temperature Bath. However, virtually any U-tube viscometer may be used, including Sil, Ostwald, Cannon-Fenske. The Auto-Viscometer must be specially modified for use with Reverse Flow Viscometers.

### 5910A Constant Temperature Bath

The Constant Temperature Bath can be used independently as a general laboratory device. However, its specifications meet the exacting requirements for precise viscosity measurements, and is especially suited for use with the Auto-Viscometer described on this page. It comes with ports for four viscometers (to mate with the four-detector capability of the Auto-Viscometer) and will maintain temperature uniformity and accuracy to 0.005°C variation up to 75°C. Port lid is easily removed for additional access. It will reduce errors due to temperature fluctuations and its temperature stability and compact size make it an ideal addition to viscometry studies. For special applications, the researcher may buy a blank lid (Ordering No. 18559A) and make his own port openings.



## AUTO-VISCOMETER

Automatic programming, recording of efflux time  
Models 5901B, 5910A, and 5903A



**MOLECULAR WEIGHT  
DETERMINATION**

### 5903A Programmer

The repetition of efflux time measurements yields data of high confidence, and final viscometry calculations will have utmost precision. A combination programmer and printer, the 5903A virtually eliminates the tedium of constant monitoring and recording of data, while giving you capability for unlimited measurements. It attaches to the Auto-Viscometer to automatically program efflux time measurements. The Programmer can control a sequential run from channel to channel (one through four on the Auto-Viscometer) and will repeat the program for as long as the operator wishes. Up to 10 repeat measurements per channel can be made, with 40-second intervals between measurements. Alternately, an unlimited number of repeat measurements can be done on individual viscometers. This automatic printout of efflux times gives you a permanent record of measurements, and is a time-saver. Each reading, moreover, is coded with viscometer number and run number. The printer is identical to HP 562A, described on page 97 in this catalog.

With the timer option, you can have an automatic system for timed interval measurements for reaction kinetic studies where a change of viscosity occurs.

The timer will set the programmer to make measurements from 5 to 100 minutes apart. Timer settings are in 5-minute increments.

### Specifications, 5901B Auto-Viscometer

**Range and resolution:** up to 1000 seconds  $\pm 0.01$  second; up to 100 seconds  $\pm 0.001$  second.

**Readout:** Neon Nixie® 5-Digit Register with decimal point indicated.

**Accuracy:** at least  $\pm 0.1$  second. Based on reproducibility of typical measurements of efflux time up to 300 seconds using Model 5910A Bath.

**Operating temperature:** 5°C to 135°C.

**Glassware\*:** detectors will accommodate viscometers with 6.5 to 10 mm diameter at point of detection.

**Response time:** 10 microseconds.

**Minimum meniscus speed:** 1 inch per minute.

**Power requirements:** 115/230 V  $\pm 10\%$ , 50 or 60 Hz, 60 watts.

**Dimensions:** 10" high, 8½" wide, 13" deep.

**Weight:** net 17 lbs; shipping 22 lbs.

\* Glassware not supplied with instrument.

### 5910A Constant Temperature Bath

**Operating range:** up to 150°C.

**Temperature control and bath uniformity:** up to 75°C  $\pm 0.005^\circ\text{C}$ ; over 75°C  $\pm 0.01^\circ\text{C}$ .

**Bath heating and cooling:** 500 watt heating coils. Cooling coils for use with external cooling system.

**Power required:** 115 V  $\pm 10\%$ , 60 Hz, 520 watts.

**Dimensions:** 22½" high, 14" wide, 19" deep.

**Weight:** net 80 lbs; shipping 90 lbs.

### 5903A Programmer

**Printer:** see specifications on HP 562A on page 97.

**Programmer:** sequence and repeat selectors for four viscometer channels.

**Power requirements:** 115/230 V  $\pm 10\%$ ; 50 or 60 Hz; 130 watts.

**Dimensions:** 12½" high, 20¾" wide, 18½" deep.

**Weight:** 35 lbs.

### How to order

Ordering No.	Description	Price
5901B	Auto-Viscometer, complete with pump and 4 sets of detectors	\$2490.00
5903A	Programmer, with printer	2600.00
	Option 01: timer for measurement intervals of 5 to 100 minutes, add	125.00
5910A	Constant Temperature Bath, with 4 viscometer clamps	1650.00
	Option 01: blank lid for constant temperature bath for special adaptations, add	52.00
	Option 02: Low Temperature Probe, add	75.00
	Option 03: Microviscometer Adapters, add	8.00

### Accessories

18545A	Spare Photocell Detector for Auto-Viscometer	185.00
18547A	Spare Viscometer clamp for Constant Temperature Bath	37.50



## ACCESSORIES

Extend usefulness, versatility of GC's

Models SI-4, 80, GV-10/11, 60, 50B, 19035A, 19034A, 220

### SI-4 Solid Sample Injector

The Solid Sample Injector is ideally suited for introducing exact weights of solid or viscous materials into a gas chromatograph and is adaptable to most makes of chromatographs. It employs a glass melting point capillary to hold and inject sample. Stainless steel, 1 lb. SI-4, Solid Sample Injector basic price: \$150.

### 80 Pyrolyzer

The Pyrolyzer (not shown) extends the scope of GC by decomposing non-volatile samples semi-automatically and is useful in analyzing large, polyfunctional molecules. Suitable for direct connection to F & M instruments, these pyrolyzers can be adapted to most other GC makes. 115 V/220 V, 60 Hz (50 Hz, optional), 16 lbs. 80 Pyrolyzer basic price, including adapters: \$350.

### GV-10/11 Gas Sampling Valves

For the accurate, reproducible and leak-free injection of gases into a GC, the Gas Sampling Valves are available with a choice of 6 sample loop capacities from 0.5 cc to 25 cc. GV-10 Gas Sampling Valves basic price without shut-off valve: \$225; with shut-off valve (GV-11): \$275.

### 60 Backflush Valve

The Backflush Valve (not shown) reverses direction of carrier gas through the column with the twist of a knob. This rapidly clears the column of unwanted components in an analysis, e.g., natural gas analysis, where only low-boilers are of importance. The valve has an integral heater and a replaceable teflon rotor with compression adjustment for leak-free operation up to 225°C and 50 psig. For proper operation, the heater requires an auxiliary controller. 60 Backflush Valve basic price without control: \$95; with control: \$195.

### 50B Automatic Attenuator

Regardless of input signal intensity, the Automatic Attenuator holds all peaks on the recorder chart. Eleven positions of binary attenuation factors from 1 through 1024 to infinity are available. The unit attenuates the signal each time the peak approaches 95% of chart width, and scales down each time the peak falls below 35% of width. All peaks are clearly identifiable. Quantitative data are readily calculated by the usual peak height or area method. 50B Automatic Attenuator basic price: \$300 (limit switches to adapt for the various makes of recorders are optional).

### 19035A Sample Injection Splitter

Specially designed for use with small-diameter, low-flow

GC columns, the Sample Injection Splitter (not shown) attaches directly to the injection port and provides a variable split ratio to give proper volume of sample injection on these columns. Includes integral heater to keep the system at injection port temperatures. Careful splitter design minimizes the ghosting, non-linear and fractionation difficulties often encountered in splitter systems. (For use with F & M Series 810 and 5750 Gas Chromatographs only.) 19035A Sample Injection Splitter price: \$125.

### 19034A Effluent Splitter

For use with F & M Series 810 and 5750 Gas Chromatographs, this splitter (not shown) converts to either three-way (for 5750) or two-way use (for either unit). It comes complete with a set of interchangeable splitters for fixed ratios in all combinations possible with 1:5:10 splits (e.g., 1:5:5, 1:10:5, 1:1:1). All mounting hardware is included for connection to 1/4" outlets.

19034A Effluent Splitter price: \$175.

### 220 Temperature Controller

Position the temperature probe and dial the desired temperature on the 220 and you have an isothermal temperature control which is responsive to deviations of less than 0.1°C. Although designed specifically for use in gas chromatography, it can be used in any application where accurate temperature control is needed. It has proportional power output and smooth control over 0-1500 watts range. 220 Temperature Controller (not shown) basic price: \$395.

### Specifications

**Readout:** dial indicator.

**Thermocouple probe:** iron-constantin with bare junction, 6 ft. leadwire; probe tip, 1/8" long x 3/16" O.D.

**Power requirements:** 95 to 125 V, 50 or 60 Hz, 1500 watts.

**Physical dimensions:** 7" high, 9" wide, 9" deep; weight 9 pounds.

### 240 Temperature Programmers

The 240 has the temperature control circuit of the 220 described above, and has a programming mechanism for temperatures from ambient to 500°C (or 1000°C as an option). Can be operated as an isothermal temperature controller, or as a temperature programmer. To program, you have twelve different heating rates which are selected by gear-shift control of a plastic gear train. These program heating rates are: 1, 2, 3, 4, 5, 7.5, 10, 15, 20, 25, and 30°C/min. Certain models have reversible programming rates. 240 Temperature Programmer, basic price (for 500°C): \$645.

## ACCESSORIES

Extend usefulness, versatility of GC's  
Models SI-4, 80, GV-10/11, 60, 50B, 19035A, 19034A, 220



## CHEMICAL INSTRUMENTATION

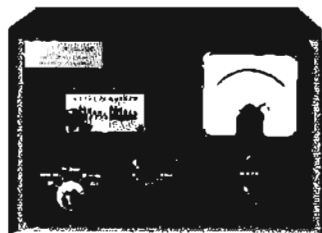

240 Temperature Programmer



50B Automatic Attenuator



SI-4 Solid Sample Injector



Gas Sampling Valve

### Specifications

**Readout:** indicating pyrometer and digital indicator.

**Thermocouple probe:** (to 500°C): Iron-Constantin bare junction, with 6-foot leadwire, probe tip, 1/8" long by 3/16" O.D. (To 1000°C): as above, with Chromel-Alumel thermocouple instead of Iron-Constantin.

**Power requirements:** 115 V/50 or 60 Hz.

**Physical dimensions:** 8 1/2" high, 12" wide, 10" deep.

**Weight:** 12 lbs.

### 19055A Total Collection System

For trapping components of a mixture as they elute from an analytical instrument, the total collection system (not shown) traps both carrier gas and component as desired. The system consists of a 300 ml glass flask, a manifold needle valve and a soap film flowmeter. Useful for small-scale collections needed in further analytical work. Requires adapters for specific instruments. 19055A Total Collection System, basic price without adapters: \$120.

### 19046A Gas Purifier

The Gas Purifier (not shown) will clean up a GC carrier gas source of contaminants which would degrade analytical results, principally unwanted oxygen, carbon dioxide, or low hydrocarbons. It is specifically recommended for use with the F & M Models 180 and 185 C-H-N Analyzers where these impurities would critically reduce accuracy of micro-analysis. The purifier consists of a molecular sieve dryer tube which removes CO<sub>2</sub> and water; a heated tube which removes hydrocarbons and CO by precombustion, and oxygen by forming CuO as the gas passes over reduced Cu. 19046A Gas Purifier, basic price: \$275.

### Thermistor probes

Thermistor probes (not shown) for the 302 Vapor Pressure Osmometer are all interchangeable and easily installed. They sense the temperature differential between solvent and solute drops within .001°C. Two types are available, one for aqueous operation; one for non-aqueous operation. See table below for prices and ordering number.

Solvent type	Operating temperature	For use with model no. 301A and 302	Ordering no.	Price
Non-aqueous	25°C	X	18501A	140.00
	37°C	X	18502A	140.00
	50°C	X	18503A	140.00
	65°C	X	18504A	140.00
	100°C	X	18509A	140.00
	130°C	X	18510A	140.00
Aqueous	25°C	X	18505A	140.00
	37°C	X	18506A	140.00
	50°C	X	18507A	140.00
	65°C	X	18508A	140.00

X = available

### Thermostats

Interchangeable with both Model 302 Vapor Pressure Osmometers and Series 500 Membrane Osmometers. These thermostats (not shown) maintain specified temperature within 0.001°C. Basic price: \$60. See table for ordering number.

Temperature control point	For use with Model No. Vapor pressure osm. Membrane osm.			Ordering No.	Price	
	301A and 302	501	502			503
5°C				X	18543A	60.00
25°C	X	X	X	X	18511A	60.00
37°C	X	X	X	X	18512A	60.00
60°C	X	X	X	X	18513A	60.00
65°C	X	X	X	X	18514A	60.00
100°C	X		X		18515A	60.00
110°C	X		X		18517A	60.00
130°C	X		X		18516A	60.00

X = available

### 18526A Variable Temperature Controller

A single device (not shown) which allows the operator a continuous control of temperatures within the range of his particular Series 500 Membrane Osmometer. It is necessary to specify serial and model number of your Membrane Osmometer to insure receipt of proper installation kit for the Variable Temperature Controller. 18526A (18562A for 50 Hz operation) Variable Temperature Controller basic price: \$375.

Further information on chemical instrumentation accessories is available in a 44-page catalog, Columns and Accessories for Chemical Instrumentation Catalog No. 2. For your copy, contact your nearest Hewlett-Packard sales office.



# Medical Instrumentation

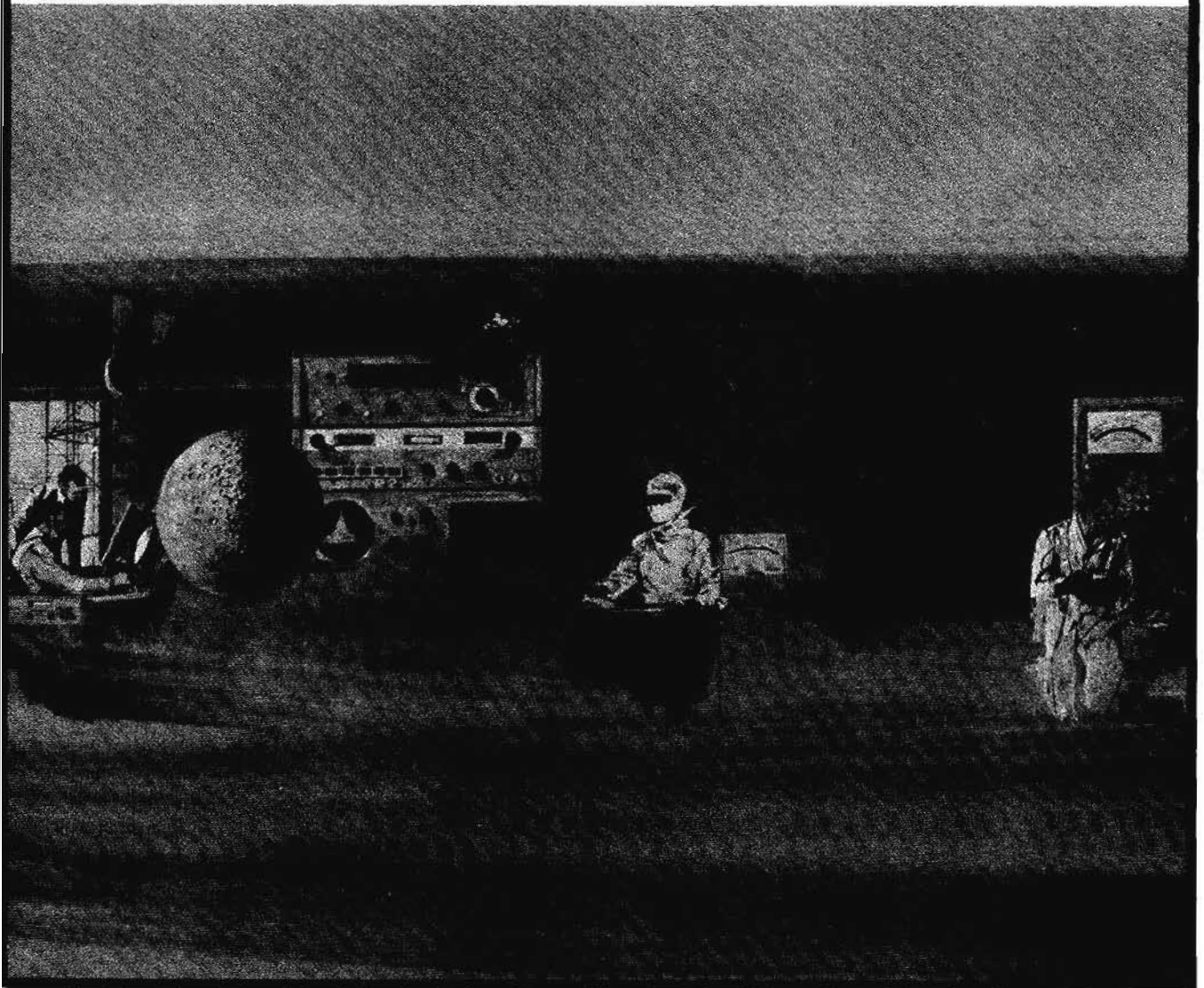

# Instrumentation for Medicine

<b>Technical Information</b> . . . . .	<b>44</b>	<b>Research &amp; Special Purpose</b> . . . . .	<b>61</b>
<b>Diagnostic</b> . . . . .	<b>45</b>	Signal Conditioners	
Hemo-Diluter		Transducers	
Blood Cell Counter		Oscillographic Recorders, thermal writing	
Metabolism Tester		Oscillographic Recorders, optical writing	
Acoustic Stethoscope		Magnetic Tape Recorders	
Electrocardiograph and Accessories		Vectorcardiograph	
<b>Patient Monitoring, Intensive Care</b> . . . . .	<b>48</b>	Ultrasonic Diagnostic System	
Bedside Monitors		Heart Sound Amplifier	
DC Defibrillator		Cardiac Output Computer	
Central Station Instruments		Thermal Dilution System	
Pacemakers		Numerical Display	
Transducers, Electrodes, Cables, Carts			
<b>Patient Monitoring, Operating Room</b> . . . . .	<b>58</b>		





*Instruments and Systems for Measuring, Monitoring and Recording Physiological Data:* The following pages summarize the main features of the majority of Sanborn instruments for clinical medicine, clinical laboratory, patient monitoring, resuscitation, multi-channel diagnosis and multi-channel research. Additionally, references will be made in the following text to various Hewlett-Packard test instruments which are applicable to the medical instrumentation listed.

### Total system concept

In order to best meet the needs of a customer in the bio-medical field, Hewlett-Packard Sanborn Division strives to provide, wherever possible, a *total* recording system rather than isolated instrument components so that our medical customer can be assured of obtaining the desired results in the most appropriate form.

A complete data acquisition system consists of a signal pick-up, signal conditioner, readout device, and as required a data storage unit.

The pick-up consists of electrodes for sensing bioelectric phenomena and transducers for converting the physical phenomena into an electrical signal. The signal conditioner simply amplifies the signal from the pick-up so that there is sufficient drive for readout devices, or the signal conditioner may modify the pick-up signal in order to convert the data into a more useful form for readout. The readout device presents the data in a form convenient for monitoring and/or study. The storage device preserves the data for readout at a later time.

The readouts can be in the form of an oscillograph, XY recorder, visual display, alarm, and/or typewriter output.

Oscillographs are available as direct-writing heated stylus type, optical photographic type, and optical ultra-violet type.

The visual displays consist of various size single and multi-channel oscilloscopes, large scale meters and numerical readouts.

Alarms are both audible and visual type.

Storage devices consist of punched tape, punched card, digital magnetic tape and analog magnetic tape systems.

The wide choice of Hewlett-Packard instrument components in the categories listed above, distinctly equips the San-

born Division to provide *total* data acquisition systems.

### Clinical medicine

The Hewlett-Packard/Sanborn Division is perhaps best known for their Model 500 Electrocardiograph, designed for both office and hospital use. Additionally, the Model 1506A Heart Sound Preamplifier is available for use with the Model 500 Electrocardiograph for recording direct-wiring heart sounds. The Sanborn Division, one of the earliest manufacturers of vectorcardiographs, is now offering the new Model 1520A Vectorcardiograph System incorporating a number of features never before available. Another new instrument for clinical medicine is the Model 7214A Diagnostic Sounder which uses ultrasonics to determine the location and movement of internal organs and is, therefore, used as a diagnostic tool in a number of different applications. The Rappaport/Sprague Stethoscope, developed after extensive research by a cardiologist-engineer team, is available to those who wish to achieve the highest possible acoustic transmission efficiency of all heart sounds.

### Patient monitoring

Patient monitoring has been shown to be of great value in the intensive care unit, recovery room, and operating room. Intensive care of patients can be aided and indeed enhanced through the use of electronic instruments which continuously observe various physiological factors such as ECG, blood pressure, temperature and respiration. The physiological data is appropriately displayed on readout devices for convenient and effortless monitoring by the medical staff. High and low limits can be set so the nursing staff can be particularly alerted when an abnormal situation occurs which may indicate patient distress.

Sanborn Division of Hewlett-Packard Company has developed a special series of electronic instruments for the particular function of patient monitoring. The 780 series of monitoring units offer many possibilities of system variations to satisfy the particular requirements of monitoring in different areas.

780 units are small, compact, self-contained instruments which are used in various combinations at the patient's bedside. Signals from the 780 units are available for use at a central station where a

number of patients may be conveniently monitored.

In some areas such as the operating room where patient monitoring is combined with the data acquisition for research, Sanborn multi-channel systems are used with either the "350" or "760" series of signal conditioners.

### Resuscitation

An isolated pacemaker and synchronized DC defibrillator is available for cardiac resuscitation in all areas of the hospital.

### Multi-channel diagnostic systems

Multi-channel systems are used routinely in cardiac catheterization laboratories to record pertinent data such as cardiac blood pressures, indicator dilution characteristics and the electrocardiogram. In the heart station, multi-channel electrocardiograms may be recorded in addition to heart sounds, ballistocardiograms, as well as various pulses. In the pulmonary function laboratory, the recording of respiratory airflows, volumes and pressures are essential in analyzing respiratory diseases.

### Multi-channel research systems

In order to provide a researcher with a system designed to suit his particular needs and to assure the greatest flexibility, Sanborn Division has a special products group which on special order provides custom-designed systems utilizing standard instrument components. The focal point of a large research system is a signal distribution panel which affords maximum flexibility in distributing signals from the various signal conditioners to the several readout devices and storage unit. Using an analog magnetic data recording unit, signals may be played back to the various readout devices with ease and if desired these playback signals may be further modified by signal conditioners in order to extract additional information from the raw data.

### Test equipment

Throughout the Hewlett-Packard catalog will be found a wide choice of electronic test equipment ideally suited for trouble shooting, alignment and performance checkout of medical data acquisition systems.

## CELL COUNTER, STETHOSCOPE

Rapid, clear data with uniform accuracy

Models 75, 74, 280, 10



### MEDICAL INSTRUMENTATION

THE SANBORN/FROMMER MODEL 75 BLOOD CELL COUNTER is a precise optical-electronic device for fast, simple, repeatably accurate counts of red and white blood cells. Operation consists of simply placing a diluted sample (see 74R, W Hemo-Diluter data below) in the reservoir and depressing the operating lever. Within six seconds and for the next 15 seconds, the cell count in cells/cu. mm is indicated continuously on the panel meter. The next sample can be poured and measured immediately. This instrument is particularly valuable in routine admission tests, diagnostic and research studies, and wherever cell counts must be made repeatedly and quickly without loss of accuracy because of operator fatigue, variation in technique, etc. SPECIFICATIONS: Scales: white cell count 0-25,000/cu. mm, red cell count 0-8 million/cu. mm; Precision: single reading repeatability  $\pm 1\frac{1}{2}\%$ ; Stability: count independent of line voltage changes between 100 and 130 volts; Blood Volume req'd: 0.05 ml for white count, 0.001 ml for red count (manual pipetting) or 0.029 ml with Hemo-Diluter; Size: 12 $\frac{1}{4}$ " high, 18 $\frac{1}{4}$ " wide including waste jar. 16" deep (310 x 464 x 406 mm); Weight approx. 44 lbs (19.8 kg); Power: 115 V, 60 Hz, 90 watts (Model 75X for 230 V, 50 Hz). PRICES: Sanborn 75 w/cab. pump and waste jar, \$1800. 75X, \$1825. 75X Option 01 (115 V 50 Hz), \$1825.

SANBORN HEMO-DILUTERS permit fast, accurate sample dilutions with pushbutton simplicity, avoiding manual pipetting and visual measurement. Dilutions accurate to  $\pm 1\%$ , reproducible to  $\pm 0.5\%$ . White-cell sample dilutions in one step, red-cell in two. Size: 11 $\frac{7}{8}$ " high, 4 $\frac{3}{4}$ " wide, 8 $\frac{1}{8}$ " deep (302 x 121 x 207 mm). PRICES: Sanborn 74R (red cell) or 74W (white cell), for 115 V, 50-60 Hz, \$375. Option 01, for 230 V, \$405 each.

THE RAPPAPORT-SPRAGUE ACOUSTIC STETHOSCOPE makes heart sounds and murmurs of the faintest level and both high and low pitches clearly audible, aiding accurate auscultation in cardiology, pediatrics and obstetrics. Specially designed chest and ear pieces, and tubing of optimal bore and length, are the result of 10 years' research by a cardiologist-engineer team. Length overall 20", rubber tubing 12" long. All chest pieces unbreakable Eastman Tenite. Five chest pieces with Model 280 include adult diaphragm for high pitched murmurs, pediatric diaphragm for high pitched murmurs, 1 $\frac{3}{8}$ " open bell for low and medium pitches, 1" open bell for localizing low and medium pitches, and  $\frac{3}{4}$ " open bell for low and medium pitches in infants. Sanborn 280 with five chest pieces and three sets ear pieces, \$25. Model 280-01 with adult diaphragm, 1 $\frac{3}{8}$ " open bell and one set ear pieces, \$19.75.

THE SANBORN METABULATOR provides graphic chart recordings of patient's oxygen consumption, from which basal metabolic rate may be quickly and accurately determined. Method is safe, time-proven by long experience, repeatable as often as needed without risk to patient or danger of results being affected by previous radiological tests. Simple operation without water or ink refill, comfortable for patient. In caster-mounted mahogany cart 33" high, 25" wide, 12"

deep (838 x 635 x 305 mm). Model 10 with oxygen tank, 0-3000 ft. barometer, for 115 V, 60 Hz, \$795. Option 03, 3000-12,000 ft. barometer, no extra charge. Option 04 less oxygen tank, \$775. Option 09 for 230 V, \$825.

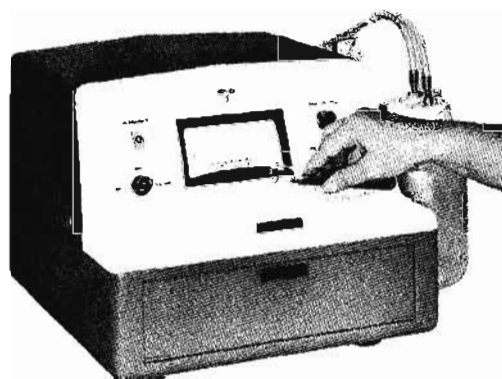

Model 75 Cell Counter



Models 74R, 74W  
Hemo-Diluters



Model 280  
Stethoscope

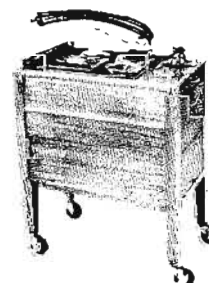

Model 10 Metabulator





## ELECTROCARDIOGRAPH

2 Speeds, 3 Sensitivities, Definitive Traces  
Model 500 Viso-Cardiette



THE SANBORN "500 VISO" is a compact, portable ECG completely modern in its physical and electronic design, which produces diagnostically-clear traces with simple, reliable operation and in a minimum of time. Special input circuits permit the use of new non-abrasive, easily applied Redux Creme; greatly reduce the possibility of "ac" interference appearing in the record; and afford better patient protection without dependence on fuses in the patient circuit. All operating controls are on the top panel, and are so arranged beneath hinged fold-back covers that only those commonly needed are normally in view. All cables, Redux Creme, electrodes and straps are readily accessible in a compartment removable for washing. Modular construction of this ECG is extremely rugged and the exterior withstands typical hard usage such instruments receive, yet lightweight aluminum throughout keeps total weight of instrument and all operating supplies down to 21 pounds. Slim profile and comfortable carrying handle make the "500" easy to carry wherever it is needed.

### Specifications

**Sensitivity:** (ac)  $\frac{1}{2}$ , 1 or 2 mV/cm, switch selected. When used as a 1-channel recorder, dc sensitivities are 25, 50 or 100 mV/cm, switch selected. Output: 1 V/cm stylus deflection.

**Chart, chart speeds:** heat-sensitive, inkless Sanborn Permapaper®, 50 mm wide, 1 mm vertical and horizontal grid, every fifth line accentuated;  $6\frac{1}{2}$ " chart visible at all times, 150-ft. roll. Chart speeds 25 and 50 mm/sec, switch selected.

**High frequency response:** two switch-selected ranges: Low, down less than 3 dB at 70 Hz; High, down less than 3 dB at 100 Hz.

**Major controls:** Off-On-Run, Power On Light, Polarity Test pushbutton, Trace Intensity, Stylus Position, Lead Marker, 1-mV Stand. signal, 9-pos. Lead Selector switch with stylus-stabilizing Instomatic action between settings (Std. 1, 2, 3, AVR, AVL, AVF, V, CF).

**Size and weight:**  $5\frac{1}{4}$ " high,  $13\frac{3}{4}$ " wide,  $13\frac{3}{4}$ " front to back (133 x 35 x 35 cm). With all accessories, 21 lbs. (9.5 kg).

**Power:** 115 V, 60 Hz, 60 watts (Model 500). For 115/230 V switch selected, 50 Hz, Model 500X. Same but 60 Hz, Model 500X Option 03. For 100 V, 60 Hz, Model 500J. For 100 V, 50 Hz, Model 500J Option 08.

### Prices:

**500 Viso-Cardiette**, 115 V, 60 Hz \$695.

Option 01: three-wire power cord; No Additional Charge.

Option 02: fine line stylus; No Additional Charge.

Option 05: modification for use with 780-13A remote switching unit, add \$150.

**500J Viso-Cardiette**, 110 V, 60 Hz \$720.

Option 01: three-wire power cord; No Additional Charge.

Option 02: fine line stylus; No Additional Charge.

Option 05: modification for use with 780-13A remote switching unit, add \$150.

Option 08: 50 Hz operation; No Additional Charge.

**500X Viso-Cardiette**, 115/230 V switch, 60 Hz \$720.

Option 01: three-wire power cord; No Additional Charge.

Option 02: fine line stylus; No Additional Charge.

Option 03: 60 Hz operation; No Additional Charge.

Option 05: modification for use with 780-13A remote switching unit, add \$150.

**For recording phonocardiograms** (heart sound tracings) of diagnostic quality, the Model 1506A Heart Sound Amplifier is especially designed for use with the 500 Viso. High resolution tracings of 50–2000 Hz heart sounds may be obtained which reveal the shape, duration and location of the sounds and murmurs, to aid in augmenting auscultation made difficult by the presence of complex arrhythmias or marked tachycardias.

**For telemetry of ECGs by Telephone equipment**, the 500 Viso is completely compatible without modification with Dataphone Transmitters 603A and 603C, and Receiver 603B. A single connecting cable (see Accessories, facing page) between Viso and Dataphone permits transmission of ECG to any diagnostic facility equipped with Dataphone Receiver.

**For scope display of ECG waveform**, particularly in ICU areas, the 500 Viso is compatible with 780-3 and 780-6 oscilloscopes (see pp. 49 and 55). For remote, automatic ECG recording at an ICU Central Station, the 500 may be used with the 780-13A Remote Switching Unit.

**For amplification/recording of other ac and dc signals**, the 500 Viso accepts ac signals from 0.1 to 100 Hz, with a max. sensitivity of 1 cm stylus deflection/0.5 mV signal; with dc signals up to 100 Hz, max. sensitivity is 1 cm stylus deflection/25 mV input signal. (For more data, consult Hewlett-Packard field office or Sanborn Division in Waltham.)

## ECG ACCESSORIES

### Cables and adapters

14000 Exercise Cable, 5-wire, with electrodes (use with 14008A Adapter)	\$21.50
14008A Adapter, 5-pin to 6-pin (for 14000, 373)	7.50
14017B Patient 3' Extension Cable (for 500)	10.50
14021A Output Cable (for 500)	11.00
14022B Standard 500 Patient Cable	11.75
10G2-36MC Output Cable, 500 to 780-3 or 780-6	5.25
460-218A Output Cable, 500 to Bell Tel. 603A, 603D Dataphone Transmitters	27.00
460-218B Input Cable to 500 from Bell Tel. 603B Dataphone Receiver	27.00
460-218C Output Cable, 500 to Bell Tel. 603C Dataphone Transmitter	37.00
651-1 Cable, Esophageal Lead (for 500)	26.50

### Carrying case

Protects 500 from rough handling; 500 held firmly against cushioning pad, may be operated while in case. Holds extra chart roll, patient records, manual. Seals tightly against moisture, has locking clasp. HP Model 7100-0466, \$50.00

### Connectors

10G2-22MW 2-pin male, dc input to 500	\$ 1.15
10G3-11MFW 3-wire power cord adapter to 2-wire outlet	.50
10G-1MW 6-pin male, ac input to 500	1.60

### Defibrillator protective network

For 500 when used with DC defibrillator. Model 14019A, \$35

### Electrodes, creme, straps

572-1717 Limb	\$2.15
572-1714 Chest, 3 cm with handle	3.05
572-1754 Infant chest, 1.9 cm with handle	3.05
233-25 Handle for chest electrode	1.40
651-80 Welsh, vacuum cup, 30 mm cup	4.50
651-81 Welsh, vacuum cup, 15 mm cup (infant)	4.50
500-602 Standard Limb	2.00
651-1021 Redux Creme, 4 oz squeeze bottle	1.10
651-1022 Redux Cream, 37 oz bottle	6.50*
651-1008 Redux Paste, 5 oz tube	.85*
572-1760 Redux Paste, 1 pt jar	2.60*
572-749 Limb strap, single perforation	.65
572-1718 Chest strap	2.40

### Master two-step

Rugged, hardwood steps 9" high, 9" deep, 17½" wide (23 x

23 x 44 cm) for standard master exercise ECG test. Folds for storage. Model 651-32, \$61.

### Mobile cabinet

Rolls easily on 5" rubber wheels. Storage drawer and bin, built-in retractable power cord, blue and cream styling. Model 500-1100, \$150. Option 01 with 3 wire power cord, no extra charge.

### Mobile table

For ECG; rolls easily to examining table or bedside. Storage drawer and shelf. Model 500-1200, \$75.

### ECG Mounting Cards, Folders, Envelopes

651-98 8½"x11" card, pregummed, 12 leads, 50 mm charts per C \$10.\*

Slotted types (records slide into windowed frames):

572-784 8½"x11" folder, 12 leads (3 std., 6 chest, 3 unipolar limb). per C \$10.00\*

572-781 8½"x11" card, 12 leads (see 572-784) per C \$9.50\*

651-34 5"x8" card, 12 lead per C \$9.05\*

651-35 8½"x11" card, 12 lead per C \$9.50\*

572-782 12 lead, requires paste or tape for mounting

per C \$6.25\*

651-36 Folder, 12 leads plus 3 extra leads per C \$10.00\*

651-6 Small record inserter, 1"x 6⅞" .55

651-84 Large record inserter, 2⅛"x10⅞" .55

P-102 Record Envelope, manilla per C 3.35\*

572-780 Record Envelope, transparent, 2¾"x8½" per C 10.00\*

### Protective Pad

Foam rubber, for ECG use on wooden table Model 77P2, \$4.

### Protective weather cover

For 500 ECG, Model 500-601, \$3.

### Permapaper® recording paper

One-channel, 50 mm, 50 div., 150' roll. Part. no. 651-40, for Models 500, 100, 51, and 572 adjusted for heavy paper. 2 rolls — \$3.50/roll; 6 rolls — \$3.35/roll; 12 rolls — \$3.20/roll.

### Styll

(Writing arms) Std. for 500 Viso, 412-5, \$7.15; fine line for 500 Viso, 412-7, \$7.15.

### Transducer, pulse wave

For use with 500 Viso; requires 14008A Adapter above. Model 373, \$71.

\* Quantity discounts apply. Consult HP Sales Office.

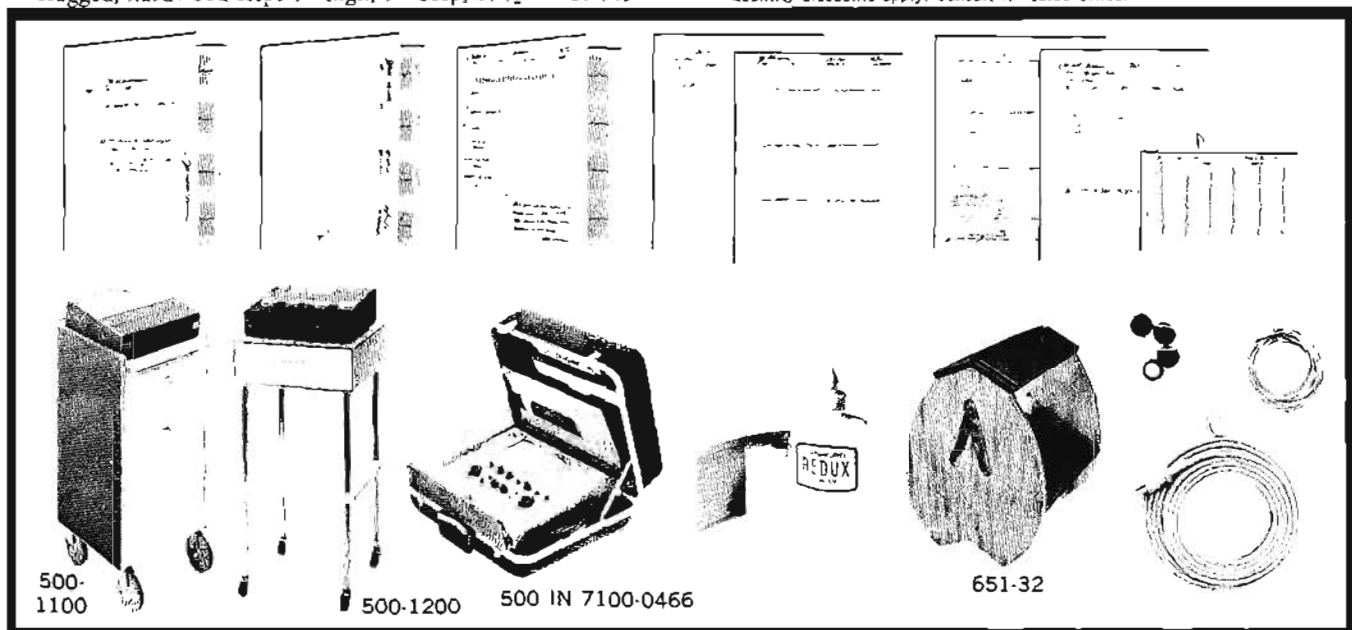

## PATIENT MONITORING- INTENSIVE CARE



## ICU SYSTEMS CAPABILITIES

Planning, installation, service  
Series 780 modules

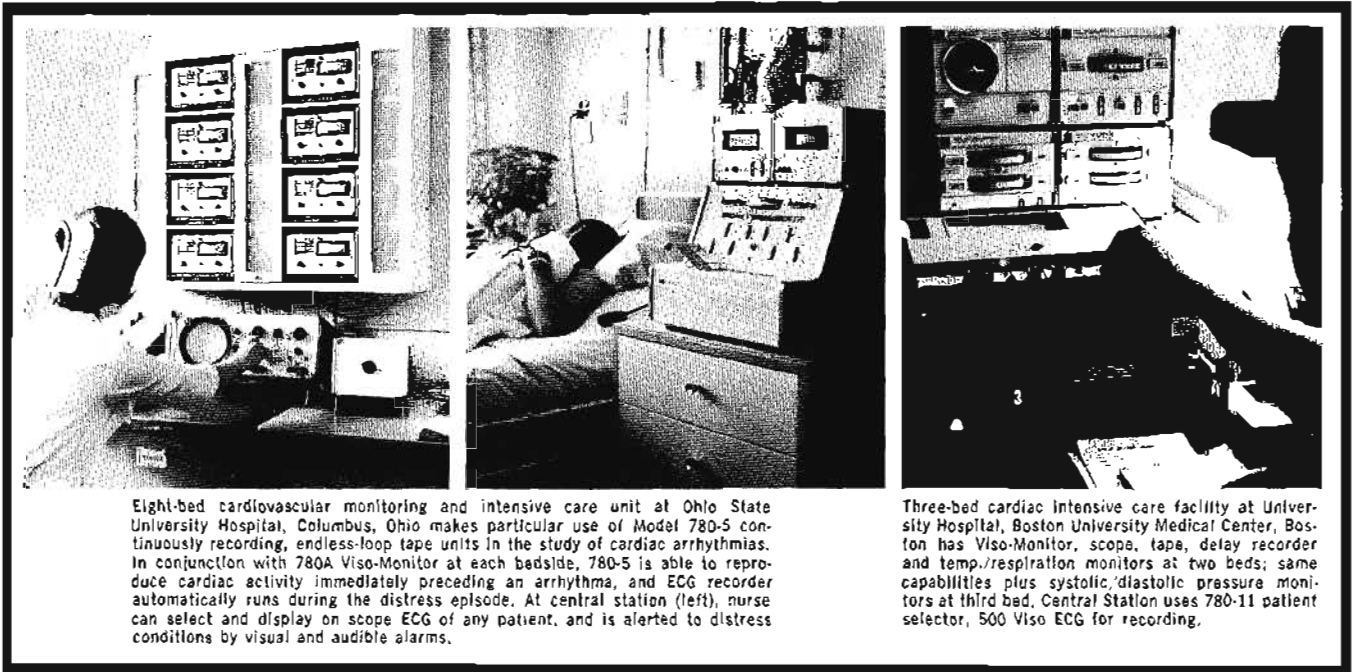

Eight-bed cardiovascular monitoring and intensive care unit at Ohio State University Hospital, Columbus, Ohio makes particular use of Model 780-5 continuously recording, endless-loop tape units in the study of cardiac arrhythmias. In conjunction with 780A Viso-Monitor at each bedside, 780-5 is able to reproduce cardiac activity immediately preceding an arrhythmia, and ECG recorder automatically runs during the distress episode. At central station (left), nurse can select and display on scope ECG of any patient, and is alerted to distress conditions by visual and audible alarms.

Three-bed cardiac intensive care facility at University Hospital, Boston University Medical Center, Boston has Viso-Monitor, scope, tape, delay recorder and temp./respiration monitors at two beds; same capabilities plus systolic/diastolic pressure monitors at third bed. Central Station uses 780-11 patient selector, 500 Viso ECG for recording.

The intensive care patient monitoring systems shown above represent but two of an almost unlimited number of systems which can be created using the 21 instruments described on the following pages, to provide the measurement, display, alarm and recording functions desired. All units in this 780 Series are electrically and physically compatible with each other. Since each provides one or more specific monitoring functions, the desired system can be easily and economically achieved by selecting only the specific modules needed. Advantages of such a "modular system" include a cost which reflects only those monitoring capabilities needed, without the penalty of obsolescence or inflexibility when the system is changed or enlarged at a future time; complete freedom to change or enlarge the system to monitor more patients, more parameters, or a different combination of parameters at each bed, as needs and budget change; and ease of combining modular 780 units at the bedside and central station, because of standardized packaging in Hewlett-Packard "half-module" and "full module" cases.

In design and performance, 780 instruments reflect thorough attention to reliability, patient safety and comfort, high readability and accuracy of data displayed, and ease of operation by hospital personnel. These characteristics are the result of features such as all solid-state circuits and operation of key components well below rated values; constant current output of pacemaker, for example, isolated from ground and power lines, and patient leads protected for use with defibrillators; lightweight patient cables and transducers for greatest patient comfort consistent with reliable operation; easy-to-read visual indicators such as rectangular, horizontal meters with large numerals, and illuminated plaques of contrasting colors to distinguish various monitored conditions; adjustable alarm delays permitting the medical staff to select

the delay interval which will prevent transients or other events of no clinical significance from triggering an alarm.

Three important advantages to the hospital, in addition to those just described relating to the 780 "modular" concept and the extremely wide choice of instruments, can help insure that the *right* patient monitoring system is installed in both existing and newly-constructed ICU's, and that the system will provide *continuing* clinical value. The first is thorough, expert system planning skills offered by Hewlett-Packard/Sanborn Division through field sales offices worldwide. Medical electronics instrumentation engineers familiar with the needs, objectives and budgets of hospitals like yours will discuss both your present and anticipated needs with you and recommend the system which most economically and flexibly meets those needs. Comprehensive, written proposals with itemized costs are always supplied prior to contract agreement. The second benefit is the availability of system installation services and responsibility for performance, from the HP sales office in your locality. Close coordination with architects, hospital staff, and local building regulations characterize this optional HP service. Finally, local HP field office men will train your staff in operating and maintenance procedures, and stand ready to provide instrument service, supplies or service contract arrangements to insure continued, reliable operation of your monitoring system.

Monitoring instruments in this section of the catalog are described in this sequence: bedside measurement/display instruments; dc defibrillators and internal/external pacemaker; central station instruments for display, alarm and recording; and related products such as transducers, electrodes, cables, mobile carts, wall mounts, etc. They are also indexed by name, function and model number elsewhere in this catalog.

## ICU SYSTEMS CAPABILITIES

Bedside scope, heart rate/ECG, temp./resp. monitor  
Models 780-3, 780-7 and 7A, 780-8



## PATIENT MONITORING - INTENSIVE CARE

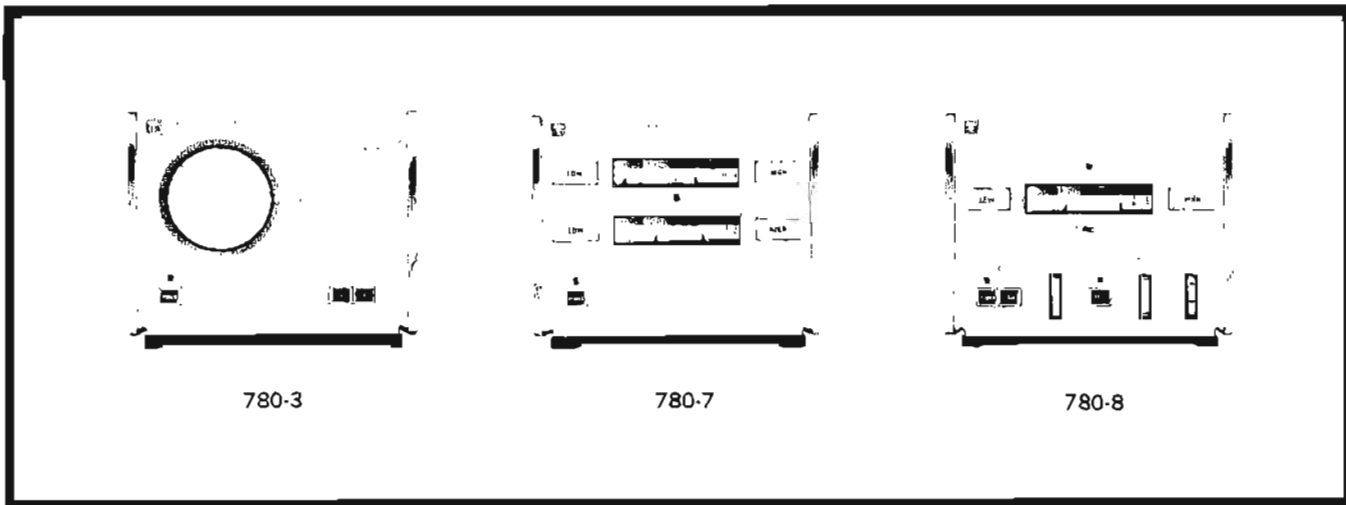

Model 780-3 Viso-Scope is a general-purpose, 3"-screen oscilloscope with slow sweep speeds and simplified controls suitable for physiologic waveform display — at the bedside, central station or elsewhere. Waveform appears as a bright, long-persistence amber trace. With proper interconnection to the ECG monitor, sweep synchronization can provide R wave superposition at the beginning of each trace sweep on the scope. This simplifies the set-up procedure for synchronized defibrillation, by causing the ECG waveform and superimposed discharge marker pulse to appear at the same position on the screen in each cardiac cycle. Sweep synchronization can also be useful for ECG waveform monitoring. Sweep speeds (25 and 50 mm/sec.) and power are push-button controls; intensity, focus, vertical position and sensitivity are screwdriver adjustments behind hinged panel. Size: 6½" high, 7¾" wide, 11" deep (165 x 197 x 279 mm) (std. Hewlett-Packard "half-module"). Weight: 10 lbs (4,5 kg). Power: 115/230 V, 50-60 Hz, 30 watts. Price: 780-3, \$495. Option 03, 2' power cord in place of 12' cord, no extra chg. Option 04, with hardware for stacking 780 half-module above, no extra chg.

Model 780-7 Patient Monitor for ECG, Pulse, Heart Rate and Pacing (Model 780-7A without Pacing) has an ECG amplifier for waveform display or recording on other units; 0-300 bpm heart rate meter with adjustable high and low threshold limits, indicator which flashes with each beat, and high and low visual alarms which light if limits are exceeded; simultaneous pulse signal (from plethysmograph or 780-9) can be used in place of ECG for determining heart rate or for pulse waveform display on associated scope.

Internal/external pacemaker provides pulses adjustable from 5 to 15 mA for internal stimulus, 50 to 150 mA for external stimulus, at rates from 50 to 150 pulses/min. Pacemaker output is isolated from ground, case and power line for safety, and is protected permitting pacemaker to remain connected if defibrillator is used. Controlled current reduces the effect of changes in patient impedance which could change the pacing amplitude; pulse duration is also fixed, for uniform cardiac stimulation. Separate, non-interchangeable

cables for internal and external pacing, with associated pacing mode selection switch, prevent incorrect connection and operation. Pace indicator on front panel lights when pacing circuit is operating. Pacemaker also delivers a blanking pulse to ECG amplifier to identify instant of pacing and allow uninterrupted ECG display or recording.

Front panel controls: power, 1 mV calibration, heart rate alarm/reset, ECG sensitivity, pacing, pace current, pace rate. Rear connectors: ECG cable, int. and ext. pacing, ac power, remote, defibrillator, pulse input, scope output and sync. output. Size: 780 half-module (same as 780-3). Weight: 10 lbs (4,5 kg). Power: 115/230 V, 50-60 Hz. Price: 780-7 with 12' power cord, ECG and pacing cables, Redux Creme, \$820. Option 03, 2' power cord, \$820. Option 04, with hardware for stacking 780 half-module above, \$820. Option 05, with audible high/low heart rate alarm, \$920. Model 780-7A (omits pacemaker), \$695. Options 03 or 04 as above, \$695. Option 05 as above, \$795. (See related transducers, cables and accessories.)

Model 780-8 Patient Monitor for Temperature and Respiration Rate displays patient's temperature from 96° to 106°F (35° to 41° C on optional version) on 3½" panel meter; each detected breath by a panel lamp flash; and respiration rate from 0 to 80 breaths/min. on another 3½" meter. Adjustable high and low limits selectable on each meter; alarm delays adjustable up to 10 sec.; indicators illuminate if any limit setting is exceeded. Temperature, respiration rate and alarm signals available at rear connector for remote monitoring (see Model 5601A Numerical Readout, page 75). Temperature may be measured by Yellow Springs series 400 rectal, esophageal or skin thermistor probe; respiration by 780-14 Respiration Transducer (see page 57). Size: 780 half-module (same as 780-3).

Weight: 8 lbs (3,6 kg). Power: 115/230 V, 50-60 Hz.

Price: 780-8 with 12' power cord, temp. meter calibrated in °F, \$675. Following Options available at no extra charge: Option 01, temp. meter in C; Option 03, with 2' power cord; Option 04, with hardware for stacking 780 half-module above.

## PATIENT MONITORING- INTENSIVE CARE



## VISO-MONITOR

Recorder; pacemaker; endless-loop tape recorder  
Models 780B, 780-5

Model 780B Viso-Monitor is a comprehensive bedside system for monitoring heart rate and peripheral pressure pulse, with visual alarms of distress conditions and signal outputs for central station display/recording; ECG recording either automatically at preset intervals, or at will; and internal or external pacemaker stimulus current delivered automatically after a selectable asystole interval, or at will.

Heart rate is displayed by a panel meter with high and low limit indicators set at desired thresholds. If either limit is exceeded beyond a preset delay period, an alarm plaque lights and the ECG recorder (if set for automatic operation) begins recording. Loss of peripheral pulse signal, or arrest, also starts recorder. For 10-sec. sampling traces periodically, the recorder can be set to run automatically at 15, 30 or 60 minute intervals; it may also be manually turned on for 10-sec. or continuous recording whenever needed. In the ECG chart margin, a marker stylus records peripheral pulse signal; this stylus also distinguishes regular interval recording by a straight line, distress recording by an oscillating line.

Internal/external pacemaker provides pulses adjustable from 5 to 15 mA for internal stimulus, 50 to 150 mA for external stimulus, at rates from 50 to 150 pulses/min. In automatic mode, pacing begins after an asystole interval selectable from 1.5 to 11 sec. Pacemaker output is isolated from ground, case and power line for safety, and is protected permitting pacemaker to remain connected if defibrillator is used. Controlled current reduces the effect of changes in patient impedance which could change the pacing amplitude; pulse duration is also fixed, for uniform cardiac stimulation. Separate, non-interchangeable cables for internal and external pacing, with associated mode selection switch, prevent incorrect connection and operation. Pace indicator on front panel lights when pacing circuit is operating. As a check on pacing effectiveness, ECG may be recorded during pacing; pulse appears as a negative spike.

**Front panel indicators:** heart rate meter (0-300 bpm); QRS, flashes white on each QRS complex; tachycardia, amber plaque lights; bradycardia, amber plaque lights; no pulse, red plaque lights after 5-sec. loss of signal; arrest, red plaque lights after 1.5 to 11 sec. absence of ECG signal; pacing, white plaque lights when pacemaker is operating; green plaque remains lighted unless ac power is lost; in-operate, red plaque lights if electrodes become loose or detached, excessive 60 cycle interference exists, paper is depleted, or stylus is off scale.

**Front panel controls:** recorder (sample, auto., run, stop, stylus heat, 1 mV cal., sensitivity, position); Viso-Monitor functions (reset, standby; monitor, off); high and low heart rate limits; pacing (current, rate; on, off, auto.); arrest delay; QRS threshold.

**Output for remote display/alarm/recording:** output jacks permit connection to hospital call system, monitor scope, 780-800B Remote Monitor (see page 54) for visual display and audible alarm, or other central station arrangements. Size: 12 $\frac{3}{4}$ " high, 16 $\frac{3}{4}$ " deep (323 x 425 x 450 mm). Weight: 46 lbs (209 kg). Power: 115 V, 60 Hz.

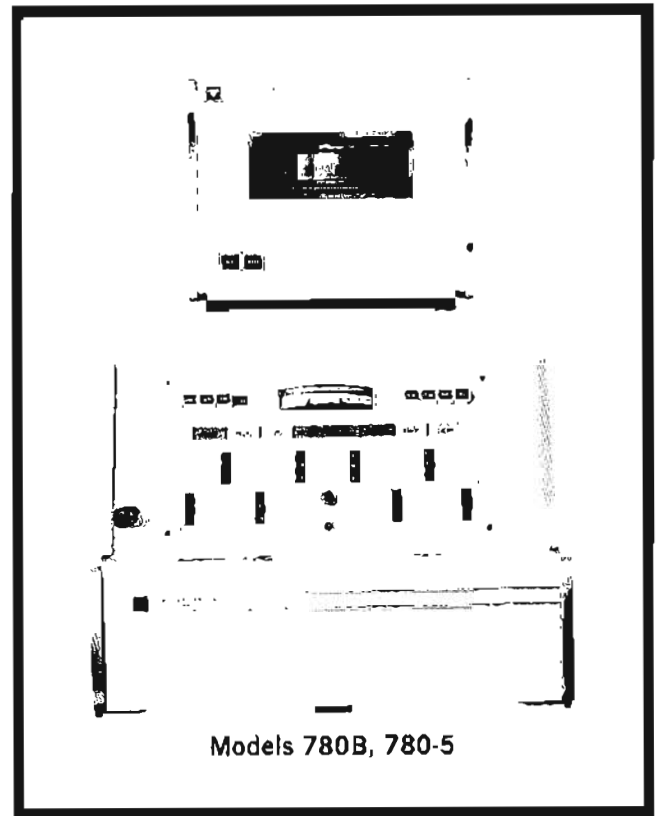

Models 780B, 780-5

Prices: Sanborn 780B Viso-Monitor with cables, Permapaper®, Redux: \$2275. Option 04, with combining hardware for two 780 half-modules, \$2275. Model 780BX for 115/230 V, 50 Hz, \$2300. Option 04, with combining hardware for two 780 half-modules above, \$2300.

**Model 780-5 Signal Delay** for continuous ECG recording on endless-loop, magnetic tape cartridge permits automatic recording of the patient's ECG *immediately preceding* as well as following any arrhythmia or cardiac distress episode. Used with the 780B Viso-Monitor, the 780-5 continuously records the ECG on an endless loop of magnetic tape of 40 seconds capacity—with new information being added and oldest being erased from the 40 seconds of signal on the tape at any time. Should a distress condition occur with the 780-5 in the Delay mode, the 780B ECG recorder is automatically turned on and records the data of the *preceding* 40 seconds from the magnetic tape, and an additional 10 seconds during the distress. Thus a permanent record is obtained for later analysis of events leading up to and during an arrhythmia or other cardiac abnormality. In the Instantaneous mode, the data storage and playback functions of the 780-5 are bypassed and all associated 780 units operate in real time. Size: 780 half-module (same as 780-3).

**Weight:** 10 lbs (4.5 kg). **Power:** from 780B. **Price:** 780-5 with 40-sec. tape cartridge, \$450. Option 04, with hardware for mounting another 780 half-module above, no added charge. 15-minute tape cartridge: see page 57.

## PATIENT MONITORING

Pressure, temperature, ECG/EEG; pacemaker  
Models 780-9, 780-18, 780-19, 780-4



## PATIENT MONITORING- INTENSIVE CARE

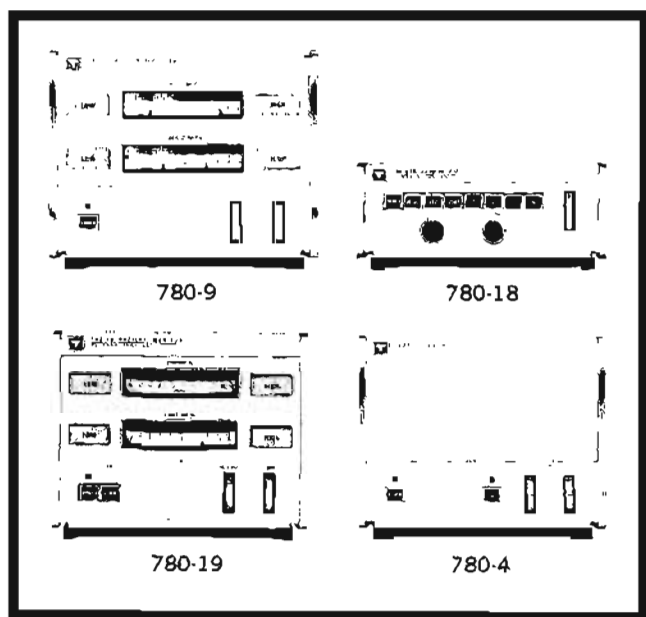

Model 780-9 Patient Monitor displays systolic and diastolic (or mean) blood pressures on separate  $3\frac{1}{2}$ " panel meters calibrated 0-300 mm Hg, gives visual warning by illuminated plaque if high or low preset limits of either pressure are exceeded, and supplies, signals and alarms at rear connector for remote monitoring. Upper and lower limits independently adjustable; alarm delays internally adjustable from 1 to 10 seconds. Signal input to this Monitor is obtained from a Sanborn 267-Series Physiologic Pressure Transducer (see pages 57, 60-61), or from a Statham P23D gage. For remote monitoring/alarm functions, the following signals are available at connectors on the rear of the 780-9: systolic pressure with high and low alarms; diastolic pressure with high and low alarms (diastolic pressure channel can be switched to read mean pressure with a switch on the front panel); arterial pressure waveform (may be used as input to 780-7, —7A to derive heart rate). Size: 780 half-module (see 780-5 opposite). Weight: 8 lbs (3,6 kg). Power: 115/230 V, 50-60 Hz. Prices: Sanborn 780-9, \$875. Option 03, with 2' power cord instead of std. 12' cord, \$875. Option 04, with combining hardware for mounting another 780 half-module above, \$875.

Model 780-18 ECG-EEG Preamplifier is a small, light-weight modular 780 instrument designed to be used with the 780-3 oscilloscope, to answer the requirements for an easily-operated basic monitoring system in the operating room and intensive care area. The simplicity and economy of the two units make possible a practical, portable monitor that can be quickly set-up at the patient's bedside in either private or ward rooms. In the operating room, the system allows the anesthesiologist to monitor the ECG waveform on the scope face, for heart rate information and detection of arrhythmias. The monitoring of EEG is frequently used as an indication of the depth of anesthesia. The system may also be used in emergency situations during application of pacing stimulus

by a 780-series pacemaker, or countershock from a 780-2T defibrillator: defibrillation and pacemaking pulses will not affect the ECG monitor. Operating convenience is afforded by front-panel pushbutton selection of ECG or EEG input; front panel connectors for patient cables; and controls for power, reset, EEG, Standby, ECG leads 1, 2 and 3, calibration and sensitivity. Size: 3" high,  $7\frac{3}{4}$ " wide, 11" deep (76.2 x 197 x 279 mm). Weight: 15 lbs (6,8 kg). Power: 115/230 V, 50-60 Hz. Price on request.

Model 780-19 Patient Monitor displays temperature and venous pressure on separate  $3\frac{1}{2}$ " panel meters calibrated 96°F to 106°F (35°C to 41°C optional) and 0 to 30 mm Hg, respectively; gives visual warning by illuminated plaque if high or low preset limits of either phenomena are exceeded; and supplies temperature and pressure output signals at rear for remote monitoring, alarm or recording. Useful in both medical and surgical intensive care patient monitoring, the 780-19 allows continuous observation of the patient with abnormally high or low body temperature, and through monitoring central venous pressure, can aid in the management of heart failure from primary and secondary causes, hemorrhage with circulatory collapse, and in judging blood volume replenishment in shock therapy. Temperature may be measured by Yellow Springs Series 400 rectal, esophageal or skin thermistor probe; blood pressure by 268A transducer using catheter (see pages 57, 60-61). Output connections at rear for remote monitoring of temperature, pressure waveform, mean pressure, high and low alarms. Size, weight and power: same as 780-9. Prices: Sanborn 780-19, \$875. Following options, no extra charge: Option 01, meter with 35°C to 41°C. Option 03, 2' power cord instead of std. 12' cord. Option 04, with combining hardware for mounting another half-module above.

Model 780-4 Pacemaker provides electrical stimulus internally or externally to cardiac patients with atrio-ventricular dissociation, ventricular slowing resulting in reduced cardiac output, or cardiac arrest. Only four controls are used: power-on, pacing-on, pacing current and rate adjustments. Pulses adjustable from 5 to 15 mA for int. stimulus, 50 to 150 mA for ext. stimulus, at rates from 50 - 150 pulses/min. Output isolated from ground, case and power line for safety, and is protected permitting pacemaker to remain connected if defibrillator is used. Controlled current reduces effect of changes in patient impedance which could change pacing amplitude. Pulse duration fixed for uniform stimulation. Separate non-interchangeable cables for int. and ext. pacing, with mode selection switch, prevent incorrect connection and operation. Front panel indicator lights when pacing circuit is operating. Blanking pulse for ECG circuit identifies instant of pacing and allows uninterrupted ECG display or recording.

Size: 780 half-module (see 780-5). Weight: 5 lbs (2,3 kg). Power: 115/230 V, 50 to 60 Hz. Prices: Sanborn 780-4 with cables and external electrodes, \$275. Option 03, with 2' power cord, or Option 04, with combining hardware for mounting another 780 half-module above, no added charge.



## PATIENT MONITORING- INTENSIVE CARE



## DC DEFIBRILLATOR

Internal or external application  
Model 780-2A

Model 780-2A Defibrillator is a dc, capacitor-discharge countershock device for termination of ventricular fibrillation—and, with optional Synchronizer circuit, for conversion of arrhythmias such as atrial fibrillation. Electrical discharge, in accordance with accepted practice, is a five msec. pulse, with an energy level of 0 to 400 watt-seconds selected by the operator. It is applied to the patient's chest wall in external defibrillation, and to the exposed heart in internal defibrillation. Significant features of this compact, all-solid-state instrument include: availability as a *dc Defibrillator only* (780-2A); as a *Defibrillator-Synchronizer* (780-2A Option 01) which permits controlled placement of the countershock within the cardiac cycle and avoidance of the vulnerable T-wave period; as a *Defibrillator with ECG circuitry* (780-2A Option 02), protected against the high potentials of the countershock pulse and with automatic baseline stabilization, for monitoring the patient's ECG waveform on an associated scope or recording it on an electrocardiograph; as a *complete synchronized defibrillation system with ECG monitoring capabilities* (780-2A Options 01 & 02) using an associated scope and/or ECG recorder.

Operating principles: an adjustable dc voltage is supplied to a capacitor which is discharged when the operator depresses a pushbutton on the handle of one of the patient electrodes. The switch actuates a relay which disconnects the capacitor from its charging circuit and connects it to the electrodes. Correct pulse shape during its passage through the patient's body is maintained by the Defibrillator's circuitry. Placement of the pulse at the desired point in the cardiac cycle is accomplished by the Synchronizer circuit in conjunction with an ECG R-wave signal supplied by the ECG circuit (Option 02) or by a 780B, 780-7, 780-7A or 780-18. Synchronizer controls allow the operator to preset the instant of energy discharge to any desired point in the ECG cycle, up to one second after the R-wave. The marker pulse of the Synchronizer also appears on the associated monitoring scope or electrocardiograph chart, enabling the defibrillator operator to see exactly where the defibrillator output will occur in the ECG cycle. Visual assurance of Synchronizer operation and sufficient ECG signal input for proper timing is supplied by an "operative" light which flashes in response to each R wave. The ECG circuitry (Option 02) supplies amplified ECG signals for monitoring and/or recording.

Rapid, straightforward operation of the Defibrillator in intensive care areas and emergency rooms is aided by the single, compact physical package of the entire defibrillator system; the clearly-marked energy-level control and associated large-scale meter; countershock discharge switch on the electrode handle, where it is under the control of the system operator only, at all times; and the positive nature of operating controls and indicators for placing the countershock at precisely the desired point in the ECG cycle. If a continuously operative (unsynchronized) mode is desired, this can be accomplished by closing the hinged door on the front of the 780-2A. The Defibrillator (alone or with Syn-

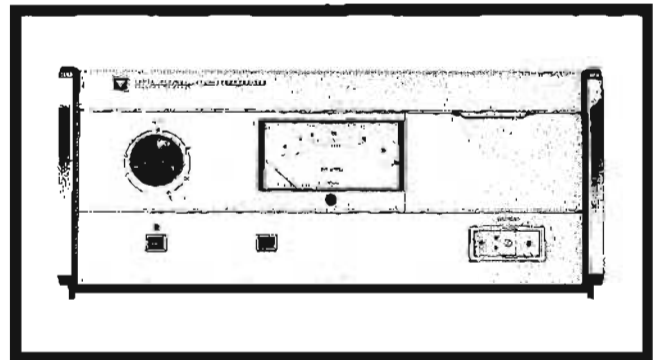

chronizer and ECG optional plug-ins), together with an associated 780-3 or 780-6 monitoring scope, 500 Viso ECG, 780-4 Pacemaker, and all necessary cables, electrodes, drugs and other items used in cardiac resuscitation can be ready for immediate use when mounted in the 780-1 Mobile Cart. The instrument may also be used with other 780-series modules as part of a bedside system. Internal or external defibrillation electrode cable plugs into a front panel receptacle; connections for ECG input, monitoring and synchronization output signals, and ac input power, are located on the rear panel.

**Size:** Hewlett-Packard full module, 7" high, 16" wide, 16" front to back (178 x 406 x 406 mm).

**Weight:** net 70 lbs (31.5 kg). Shipping 82 lbs (37 kg).

**Power:** 115 V, 15 amp surge during charge (0.3 amp to hold full charge), 50 to 60 Hz. For operation on 115/230 V, switch-selected, 50 to 60 Hz, Model 780-2AX is available (see Price section below).

### Prices:

Sanborn 780-2A Defibrillator only, for 115 V, 50 to 60 Hz, with external electrodes	\$ 950
780-2A, Option 01, with Synchronizer plug-in	\$1100
780-2A, Option 02, with ECG Amplifier plug-in, ECG patient cable and access	\$1150
780-2A, Options 01 and 02, with both Synchronizer and ECG Amplifier plug-ins	\$1300
Option 04, combining hardware for mounting two 780 half-modules on a 780-2A	n/c
Sanborn 780-2AX Defibrillator only, for 115/230 V, 50 to 60 Hz, with external electrodes	\$ 975
780-2AX, Option 01, with Synchronizer plug-in	\$1125
780-2AX, Option 02, with ECG Amplifier plug-in, ECG patient cable and access	\$1175
780-2AX, Options 01 and 02	\$1325
Option 04, with combining hardware for mounting two 780 half-modules on a 780-2AX	n/c

See 780-Series Accessories section, for cables, electrodes, supplies.)



## CENTRAL STATION DISPLAY

Alarm and signal switching units  
Models 780-11, 780-12, 780-13A



PATIENT MONITORING-  
INTENSIVE CARE



780-11



780-12

Model 780-11 Patient Selector combines visual and audible patient distress alarms with patient signal switching to associated display or recording instruments. Used at the central station, the 780-11 is connected to patient signal cables from the monitors at up to eight beds, and has output connections to whatever display/recording instruments are used at the central station. Prominent red numerals 1 through 8 on the front panel are illuminated at a low intensity to show that monitoring equipment is "on" and functioning at up to eight beds; if a monitored condition *exceeds* the upper or lower limits preset by the physician at the bedside, a chime alarm in the 780-11 sounds at five-second intervals and the numeral for the patient in distress flashes at full brightness at one-second intervals.

Display switching to associated instruments such as a 780-6 Viso-Scope, 5601A Numerical Display, 500 Viso ECG or multi-channel strip chart recorder is initiated by the central station attendant by depressing the pushbutton on the 780-11 below the appropriate patient numeral, which transfers any two of the monitored signals to the display or recording device. A white indicator light above the pushbutton lights to show that this monitoring function is occurring. Compact modular cabinet has tilt stand to provide best viewing angle; a 780-11 may be stacked with a 780-6A Viso-Scope, or several 780-11's stacked together to accommodate more than eight patients (also see 780-13A below for expanded and/or automatic readout capabilities).

**Size:** 37/8" high, 163/4" wide, 131/4" deep (98 x 425 x 343 mm).

**Weight:** 13 lbs (5,9 kg).

**Power:** 115/230 V, switch selected, 50-60 Hz, 30 watts.

**Price:** Sanborn 780-11, \$700.

Model 780-13A Automatic/Auxiliary Signal Switch (not illustrated) expands the capabilities of a 780-11 to more signals per patient and an automatic mode of signal transfer to associated display/recording instruments. The unit, which is mounted inside the junction box at the central station, offers the following choice of operating modes: (1) transfer of up to 12 signals per patient to associated display/recording instruments at the central station, by depressing pushbutton on 780-11 corresponding to desired patient (780-13A, Option 02); (2) automatically detect an alarm condition at any one of eight beds, turn on a Model 500 Viso ECG and record for a period (selectable by operator) from

5 to 25 seconds, activate the 500's marginal marker stylus to produce a coded patient identification, and turn off the 500 Viso at the end of the recording cycle and reset the circuits (780-13A, Option 01); or (3) automatically transfer, on alarm, *all* monitored signals for that patient to the readout devices in use at the central station (780-13A, Options 01 and 02). This automatic response to alarm conditions described in (2) and (3) above occurs after the central station attendant depresses the "AUTO" pushbutton on the 780-11. A valuable additional operating feature is also present in either of these modes: if a *second* patient alarm occurs while the display/recording instruments are operating in response to a prior alarm, the second alarm will be sensed and stored until the first 5-25 second period ends, whereupon immediate signal transfer will be made to the second alarm condition.

**Prices: Sanborn 780-13A, Option 02:** (transfer of up to 12 signals per patient when 780-11 pushbutton is depressed), \$625 with relay assemblies for 8 patients; if capacity for less than 8 patients is desired, price is lowered by \$50 for each patient less than 8, to \$325 for unit with two-patient capacity.

**780-13A, Option 01:** (automatic ECG recording on modified 500 Viso, Option 05), \$575.

**780-13A, Options 01 and 02:** \$625 for one relay, one-patient capacity, to \$975 for eight relays, eight-patient capacity; for each patient less than eight, subtract \$50 from \$975 price.

Model 780-12 Patient Alarm Display is a large wall-mounted unit for alerting personnel in the central station area to patient distress conditions. Alarms sensed by bedside monitors, for any of four conditions at up to eight beds, actuate a repeating chime in the 780-12 and illuminate a patient-identifying numeral for the alarm condition. Condition names (such as temp., heart rate, resp. rate, blood pressure) and patient numerals are in red, 11/2" high, easily readable from a distance. Unit mounts on swivel bracket for best viewing angle.

**Size:** 93/8" high, 231/2" wide, 51/8" deep (238 x 597 x 130 mm).

**Weight:** 12 lbs (5,4 kg).

**Power:** 115/230 V, 50-60 Hz, 50 watts.

**Price:** Sanborn 780-12 with mtg. hardware, \$1000.

## PATIENT MONITORING- INTENSIVE CARE



## VISO-SCOPE

Central station display & alarm units  
Models 769A, 768S, 780-21, 780-800B

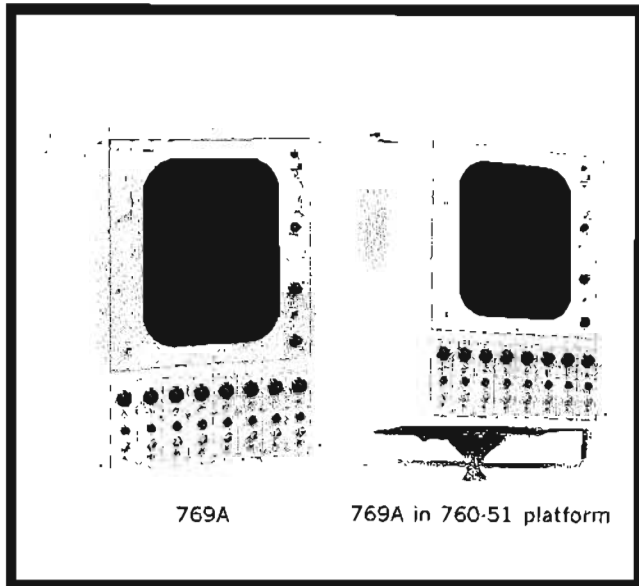

769A

769A in 760-51 platform

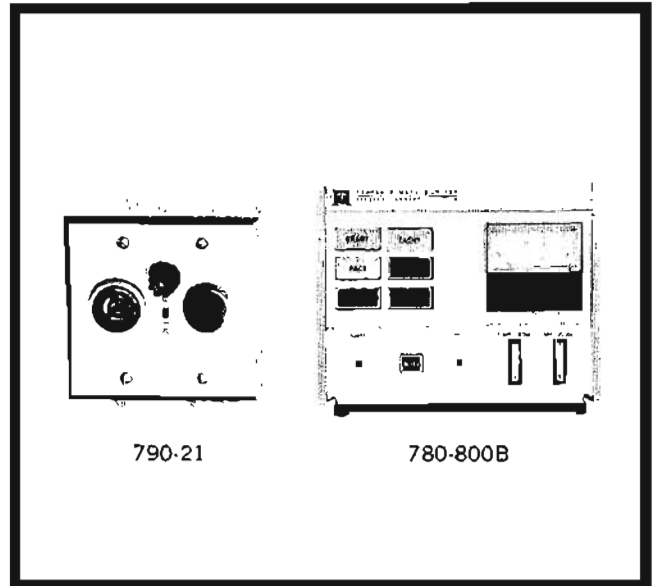

790-21

780-800B

### Models 769A and 768S Viso-Scopes

Models 769A and 768S Viso-Scopes are 17"-screen oscilloscopes capable of displaying up to eight waveforms simultaneously, for accurate interpretation from a distance in the ICU central station, OR, catheterization laboratory or similar location. They are designed to be used with Sanborn signal conditioners, patient monitors, oscillographic and magnetic tape recording systems, and obtain their inputs from the signal conditioners in these systems. Gating amplifiers (individual channel plug-ins in the 769A, 8-channel unit in the 768S) are located below the CRT and function as an electronic switch. Controls permit positioning any waveform anywhere on the screen. Input sensitivity is 5 in/V (769A) and 2 in/V (768S). Scope front panel is pivoted within cabinet to permit tilting forward up to 20°; grid overlay facilitates amplitude measurements. Polaroid filter minimizes interference from room lights.

Specifications of 769A include automatic sweep periods of 3, 6, 12 sec, manual 3, 6, 12, 30 sec; sweep linearity better than 3%; freq. resp. dc to 3 dB down at 1 kHz; input balanced or single-ended, impedance 400 k; common mode rejection 40 dB min., max. voltage  $\pm 15$  V. Size: 28" high, 19" wide, 21" deep (711 x 483 x 533 mm). Weight: 115 lbs (52 kg), with 8 gating amplifiers. Power: 115 V, 50-60 Hz, 275 watts. Option 09, 230 V. Price: Sanborn 769A with cabinet, without gating amplifiers, \$1365. Model 779-100 Gating Amplifier, one per channel reqd., \$150 each. Option 09 for 230 V, no added charge. Model 769 AR, same as above but for rack mounting, no added charge. Price: Sanborn 768S with cabinet and 8-channel gating amplifier, \$1990. Option 09 for 230 V, no extra charge. Model 768SR for rack mounting, no extra charge.

### Model 780-21 remote alarm indicator

Model 780-21 Remote Alarm Indicator is a simple, compact and economical unit consisting of a red light and re-

peating tone, to alert personnel in corridors, doctor's or nurse's lounge, etc. of distress conditions. Each 780-21 can serve up to four monitoring instruments at each of eight beds. It includes a call relay which may be used to turn on a call bell or indicator at an alternate location.

Compatible with bedside 780-7/7A, -8, -9, -19, 780B units, central station 780-11, -12. Connection can be with conduit, surface raceway or exposed cabling. Size: two-gauge aluminum NEMA box, 5" high, 5" wide, 3" deep (127 x 127 x 76 mm). Weight: 5 lbs (2,25 kg). Power: 115/230 V, 50-60 Hz. Price: Sanborn 780-21, \$125.

### Model 780-800B remote monitor

Model 780-800B Remote Monitor is the companion unit to the 780B Viso-Monitor, duplicating all visual displays of the Viso-Monitor and also providing audible signals for each QRS complex (beep) and any of the four distress conditions (steady tone). Individual volume controls permit adjustment of each sound. A single switch on the Viso-Monitor resets both bedside and remote visual indicators. Remote Monitor also has output jack for oscilloscope monitoring.

Indicators on the Remote Monitor include: Heart Rate meter (0-300 bpm), Tachycardia (amber), Bradycardia (amber), No Pulse (red), Arrest (red), QRS Complex (white, flashing), Pacing (white), Inoperate (red), and Power (white).

Size: std. HP half-module 7 $\frac{7}{8}$ " wide, 6 $\frac{1}{2}$ " high, 11" deep (197 x 165 x 279 mm); easily stacked or combined side-by-side with other 780 units. Weight: 8 lbs (3,6 kg). Power: from 780B. Price: Sanborn 780-800B with 50' cable, \$265.

For Numerical Readout and Graphic Recording Facilities at the central station, refer to Model 5601A and Model 500 Viso-Cardiette.

# VISO-SCOPE

Simple, accurate physiological monitoring  
Model 780-6A



## PATIENT MONITORING- INTENSIVE CARE

Patient signals can be accurately observed on the Model 780-6A general purpose 5-inch oscilloscope. ECG, pressure, pulse and other patient signals can be observed as sharply defined displays, due to the slow sweep speeds and long-persistence scope image. With the optional electronic switch, four patient signals can be monitored simultaneously. The electronic switch accepts eight rear panel inputs, any four of which may be selected for viewing on the oscilloscope screen. The modular design of the Model 780-6A allows it to be used with other 780-series modules either at the nurses station or at the patients bedside, or it may be easily converted for rack mounting in compatible recording systems.

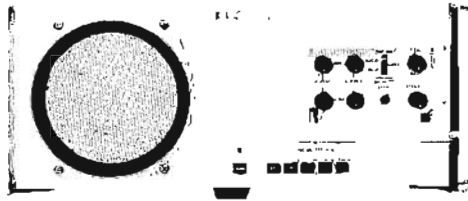

### Specifications

#### Time base

**Range:** 25, 50, 100 mm/sec and X10 multiplier (X.1 multiplier available on special order); accuracy  $\pm 5\%$ .

**Triggering:** free run, normal, or triggered.

**Free run:** circuit free runs independently of trigger circuit.

**Normal:** circuit free runs, can be reset any time after 5 cm of sweep by applying ext trigger of 5 V or greater (jack on rear panel); input RC, 100K ohms shunted by 40 pF; max input 15 V.

**Triggered:** initiated by ext trigger signal, or front panel pushbutton; sweep can be reset in same manner as Normal.

#### Vertical amplifier

**Bandwidth:** dc to 200 kHz. (Option 01, see below.)

**Deflection factor (sensitivity):** variable from 100 mV/cm to 1 V/cm.

**Balanced input:** connections for +, -, and ground provided.

**Common-mode rejection:** greater than 40 dB for common-mode signals of less than  $\pm 3$  volts at 1 kHz.

**Input RC:** 1 megohm shunted by approximately 200 pF from each side of balanced input to ground.

#### Connectors:

**Y vertical input:** 3-conductor phone jack on rear panel.

**Y vertical output:** 3-conductor phone jack on rear panel in parallel with Y vertical input.

#### Option 01 (four-channel electronic switch):

**Chopping rate:** 40 kHz (10 kHz per channel when all four channels are turned on).

**Connectors:** Amp Series M 14-pin connector on rear panel;

2-conductor phone jacks in parallel with inputs 1 through 4 on rear panel.

#### Each channel:

**Bandwidth:** 1 kHz.

**Deflection factor (sensitivity):** set simultaneously for all channels with one control; variable from about 200 mV/cm to about 2 V/cm.

**Input RC:** single-ended, 20K ohms shunted by 80 pF.

**Controls:** position control, and 9-position switch allowing each channel to be connected to any one of eight rear panel inputs or Off.

#### Horizontal amplifier

**Bandwidth:** dc to 70 kHz.

**Deflection factor (sensitivity):** 0.5 V/cm, variable  $\pm 25\%$ .

**Balanced input:** connections for +, -, and ground provided.

**Common-mode rejection:** greater than 40 dB for common-mode signals of less than  $\pm 3$  volts at 1 kHz.

**Input RC:** 1 megohm shunted by approximately 160 pF from each side of balanced input to ground.

**Connector:** 3-conductor phone jack on rear panel.

**X-Y operation:** selectable with front panel pushbutton.

#### General

**Cathode ray tube:** mono-accelerator, 2500-volt accelerating potential; supplied with P7 long persistence phosphor and amber filter; etched safety glass faceplate reduces glare.

**Graticule:** 10 x 10 cm parallax-free internal graticule marked in cm squares; major horizontal and vertical axes have 2 mm subdivisions.

**Intensity modulation:** +5 V pulse will blank trace of normal intensity; z-axis input, dc coupled; input is to 2-conductor phone jack on rear panel; input impedance, 25K ohms; maximum z-axis input, 10 V.

#### Location of controls:

**Front panel:** power, sweep speed, X-Y and multiplier.

**Behind door:** focus, intensity, X and Y sensitivity and position, sweep mode, and manual trigger.

**Dimensions:** 16 $\frac{3}{4}$ " wide, 7 $\frac{1}{2}$ " high, 18 $\frac{3}{8}$ " deep overall (426 x 191 x 466 mm); hardware furnished for quick conversion to 7" x 19" (178 x 483 mm) rack mount.

**Color:** blue cabinet with white enamel front panel standard; gray panel available, see options.

**Weight:** net 27 lbs (12.2 kg); shipping 33 lbs (14.9 kg).

**Power:** 115 or 230 volts  $\pm 10\%$ , 50 to 1000 Hz, approx. 95 W; Aux. power output (5 amp max.) is provided for connecting other equipment.

**Price:** HP Model 780-6A, \$700.

#### Options: (specify by option number)

01: 4-channel electronic switch for vertical amplifier, add \$175.

04: combining hardware for mounting two half-modules on top of a Model 780-6A, no additional charge.

05: gray front panel instead of standard white, add \$25.

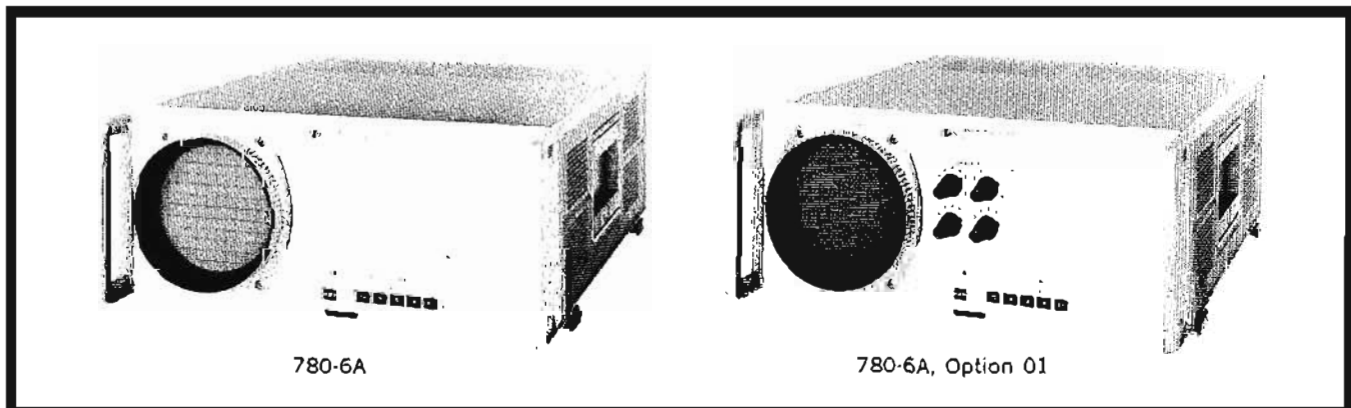

780-6A

780-6A, Option 01

## PATIENT MONITORING- INTENSIVE CARE



## MONITOR SCOPES

General purpose physiological monitoring  
Models H40-120B, H41-120B

The Hewlett-Packard Monitor Scopes are special purpose, two-sweep-speed, long persistence oscilloscopes specially suited for all types of physiological monitoring. Individual ECG, pressure, pulse, and other patient signals can be observed as a sharply defined display, due to the slow sweep speeds and clear, long-persistence scope image.

These economically priced oscilloscopes are designed for ease of operation, even by non-technical personnel. Standard ECG sweep speeds are selected by a toggle switch on the front panel. All operating controls are simplified as well as being kept to a logical minimum.

The Model H41-120B has several additional features over the Model H40-120B. An additional preamplifier has been added which enables the instrument to accept signals as low as 500 microvolts and still provide at least 1 cm of deflection on the screen. The Model H41-120B has two input capabilities which are selected with a rear panel switch; one is a 2-conductor phone jack on the rear panel for a single-ended input of 0.1 to 1 volt (in this mode the Model H41-120B is, in effect, converted to the Model H40-120B configuration), and the other is a standard 5-pin MS type connector on the front panel for a differential input of 0.5 to 5 millivolts. Sensitivity of both inputs is variable with a front panel control. For patient protection, a 5 milliamp fuse is added in series with the signal ground. Also, on the Model H41-120B a 1 millivolt calibrator has been included. Upon actuation of a momentary pushbutton switch on the front panel, a 1 millivolt signal is applied to the preamplifier, thus producing a step of known amplitude on the waveform being displayed.

### Note:

Another oscilloscope that has proven very useful in medical applications (especially research) is the Model 132A Dual Beam Oscilloscope (page 424). The exceptional versatility of this scope is a result of the two completely independent beams in the CRT. This capability gives the physiologist or biochemist an unusually wide range of display possibilities for simultaneous measurements of two different physiological parameters — quantitatively and qualitatively in time.

### Specifications, H40-120B

#### Vertical amplifier:

**Bandwidth:** dc to 50 kHz.

**Deflection factor (sensitivity):** variable from 100 mV/cm to 1 V/cm.

**Input:** single ended on rear panel.

**Input RC:** 1 megohm shunted by approximately 150 pF.

**Input connector:** two-conductor phone jacks (2) in parallel on rear panel.

#### Time base:

**Range:** 25 and 50 mm/sec.

**Triggering:** sweep circuit free-runs.

#### General:

**Cathode ray tube:** mono-accelerator, 2500-volt accelerating potential, supplied with P7 long-persistence phosphor, and amber filter.

**Graticule:** 10 cm by 10 cm parallax-free internal graticule marked in cm squares; major horizontal and vertical axis have 2mm subdivisions.

**Dimensions:** 16¾" wide, 7½" high, and 18¾" deep overall (426 x 191 x 466 mm).

**Color:** blue cabinet with white enamel front panel standard; gray panel available on special order.

**Weight:** net, 26 lbs (11.7 kg); shipping, 32 lbs (14.4 kg).

**Power:** 115 or 230 volts  $\pm 10\%$ , 50 to 1000 Hz, approximately 95 W.

**Price:** HP Model H40-120B, \$525.

#### Accessories available:

Rack mount kit (order HP part number 5060-0433), \$10.

Handle kit, contains two handles and mounting hardware for installation on instrument side castings (order HP part number K04-120B), \$10.

Testmobile, designed so that instrument height above floor may be varied from 5 to 6 feet (approximately); instrument may be tilted to any position (order HP Model K41-1118A), \$135.

#### Options: (specify by option number)

04: combining hardware for mounting two half modules on top of the instrument, no additional charge.

20: tone generator; provides a 150 msec burst of approximately 700 Hz tone, triggered by the R wave; front panel controls for volume and R wave trigger sensitivity, add \$65.

21: rear panel signal outputs; two BNC connectors on rear panel provide approximately 1 V/cm and 1 mV/cm analog outputs, add \$50.

### Specifications, H41-120B

Same as Model H40-120B except:

#### Vertical amplifier:

**Bandwidth:** 0.15 Hz to 1 kHz (time constant 0.5 sec).

**Deflection factor (sensitivity):** variable from 500  $\mu$ V/cm to 5 mV/cm.

**Balanced input:** connections for +, -, and ground are provided.

**Common mode rejection:** greater than 60 dB for common mode signals of less than  $\pm 1$  volt.

**Input RC:** 1 megohm shunted by approximately 150 pF from each side of balanced input to ground.

**Input connector:** amphenol 5-pin jack on front panel.

**Calibrator:** 1 mV signal initiated by front panel pushbutton.

**Patient protection:** 5 mA front panel fuse.

**Price:** HP Model H41-120B, \$625.

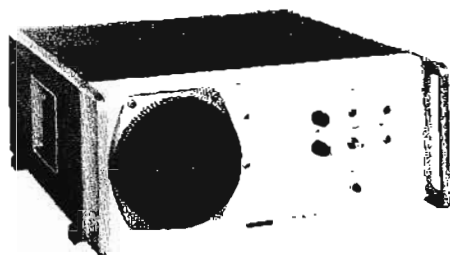

H40-120B



K41-1118A

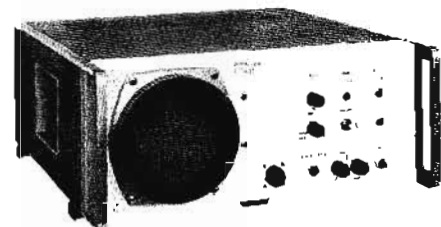

H41-120B

# PATIENT MONITORING

Transducers, electrodes, cables, carts, brackets  
267, 780, 37P, 48 and 651 Series



## PATIENT MONITORING- INTENSIVE CARE

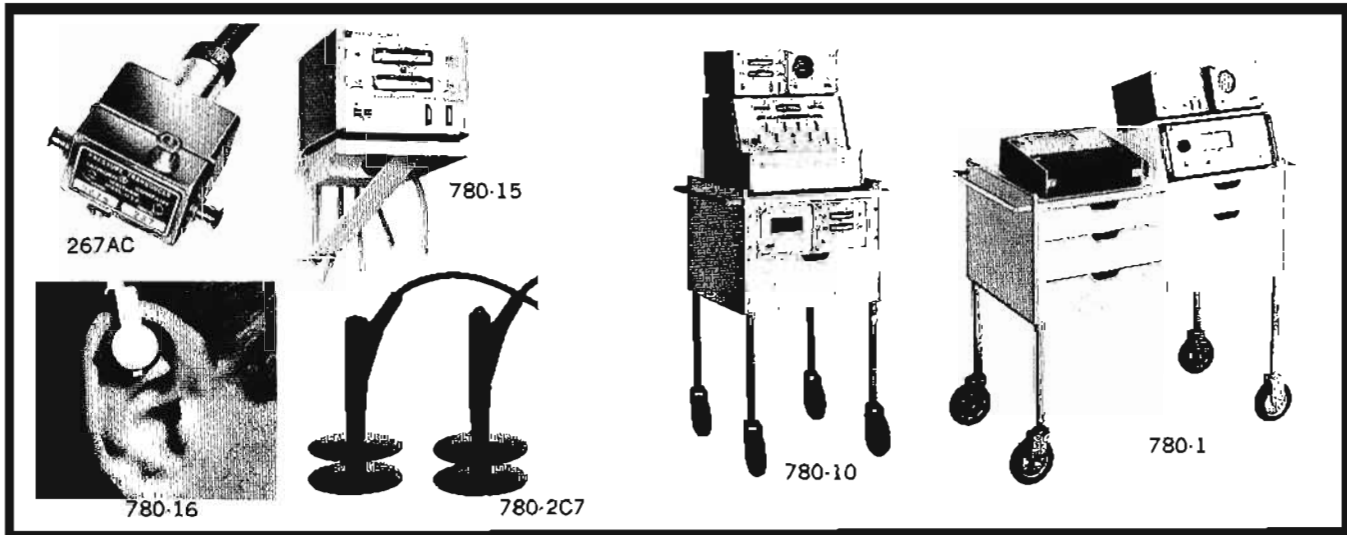

### Transducers and electrodes

267AC	Fluid pressure, -100 to +400 mm Hg. Luer taper-twist connectors, 8' cable, Monel construction. Use with 780-9	\$225
780-14	Respiration rate, detects chest expansions/contractions as small as 0.021". Use with 780-8, 760-2200 resp rate preamp	\$100
37P-series	Thermistor temperature probe. Use with 780-8	
37P-401	Internal esophageal-rectal	\$ 15
37P-402	Rectal, infant	27
37P-403	Tubular	23
37P-405	Surface (air)	30
37P-406	Tubular	30
37P-408	Surface (banjo-type)	29
37P-409	Surface	23
780-16	Earpiece photo-plethysmograph. Detects blood pressure pulsations in pinna of the ear photo-electrically. Use with 780-7, -7A, 780B.	\$100
780-2C7	Defibrillating electrodes, external. Paddle-type; pushbutton switch on handle. Use with 780-2A.	\$ 75 pr.
780-2C8	Defibrillating electrodes, internal. Use with 780-2A.	\$150 pr.
780-2C17	Defibrillating electrodes, infant, internal. Use with 780-2A.	\$150 pr.
14013A	Defibrillating, Anterior-Posterior electrodes, external. Use with 780-2A.	\$160 pr.

### Cables

780-1200-C8	Pacing, internal. Use with 780B, 780-4, 780-7.	\$ 11
780-1200-C9	Pacing, external. Use with 780B, 780-4, 780-7.	\$ 11
780-1200-C10	ECG with fluid-column electrodes. 8' long. Use with 780B, 780-7/7A, ECGs.	\$ 13

### Wall Mount Bracket

780-15	Rugged, easily-mounted unit holds up to two 780 half-modules. Swivel bracket facilitates cable connections, best viewing angle. Wall-mounting frees area around bedside, protects monitors from possible damage. With all mounting hardware.	\$ 35
--------	--	-------

### Mobile Instrument Carts

780-1	Useful as emergency resuscitation cart for quickly getting all instruments, drugs and supplies to the patient, or as a bedside cart for a monitoring system. Sloping compartment at right holds 780-2A Defibrillator or 780-6, two half-modules or one full-module on top. Model 500 Viso ECG or a full-module mounts on top left. Four drawers and storage compartments hold all cables, electrodes, drugs, etc. Handles at both ends; 6" ball-bearing wheels, conductive tires; four electrical outlets at rear, 15' three-wire power cord. Size: 42" high, 43½" wide, 20⅞" deep (1067 x 1105 x 524 mm). Weight 138 lbs. (62 kg). Price \$345. Following options at no extra charge: Option 04: combining hardware for mtg. two half-mods. on sloping section. Option 05: combining hardware for mtg. full mod. on sloping section or left top. Option 07: combining hardware for mtg. 500 Viso on left top.
780-10	Same features as 780-1 cart, in smaller size—37½" high, 26⅞" wide, 20⅞" deep (953 x 670 x 524 mm). Wide flexibility in mounting half- or full 780 modules. Weight 81 lbs. (36 kg). Prices: 780-10 with one drawer, \$195; 780-10A, no drawer, \$165; 780-10B, two drawers, \$245. Fol. options supply combining/mtg. hardware for modules: Option 03: two half-modules in space below top, add \$42. Option 04: two half-modules on top of cart, no charge. Option 05: 780B or 780-2A on top of cart, no charge. Option 06: full-module in space below top, add \$30. Option 07: 500 Viso on top of cart, no charge.

### Magnetic Tape Cartridges, endless-loop, for 780-5

48A-27A	40-sec. capacity	\$ 5.50
48A-27G	15-minute capacity	\$ 10.00

### Permapaper® Recording Chart Paper

651-190	40 div., 35 mm wide, for 780B	\$ 2.75
651-40	For 500 Viso	\$ 3.50

**Electrical Fittings and Supplies for 780 Systems:** a wide choice of junction boxes, terminal boxes, interconnection yokes, cables in std. and special lengths with specific terminations required, and mounting hardware for 780-series patient monitoring systems is available. Consult your local Hewlett-Packard field sales office for details.

## PATIENT MONITORING- OPERATING ROOM



## OPERATING ROOM SYSTEMS

Systems engineering approach  
Recording and display instruments

A wide choice of OR patient monitoring systems is available from Hewlett-Packard, primarily because no two hospitals have exactly the same patient phenomena to monitor, identical physical locations and system operating conditions, or the same budgetary considerations. Provision is made for incorporating instrumentation advances into existing systems, thus avoiding system obsolescence.

The two installations shown below on this and the facing page are but two of many complete monitoring systems designed, built and installed by Hewlett-Packard/Sanborn Division during the last 20 years. Each system incorporates the most appropriate signal acquisition, signal conditioning, visual display and recording elements for the type of surgery and medical staff who use the system — with the functional elements drawn from the individual instruments shown between the installation photos and from others described in the Research Instruments section of this catalog.

Functional elements available for OR monitoring systems from Hewlett-Packard include: *transducers* for translating the patient's physiological variables into representative electrical signals; *signal conditioners* for amplifying, refining or selecting certain portions of these signals; *visual display devices* for

continuous monitoring of patient signals during the operation, and possible subsequent study or teaching of operative events through the medium of magnetic tape playback; *graphic recording instruments* for obtaining data in permanent chart form, either during surgery or later by data playback; and *magnetic tape instrumentation* for acquiring all data, preserving its original electrical form, and reproducing it at its original rate or at a faster or slower rate as the investigator desires. (Patient data on magnetic tape also facilitates its analysis by computer, if this is contemplated by the hospital staff.)

Examples of the specific Hewlett-Packard medical electronics products in each of these categories can give the hospital a measure of choices available in system capabilities. Medical transducers include types for the detection/measurement of heart sounds; peripheral pressure pulse; respiration rate; fluid and membrane pressures; gas pressures; myographic forces; internal and external temperatures; linear displacement and velocity; pO<sub>2</sub> of gas, blood and other fluids. *Signal conditioners* provide maximum flexibility of control and fidelity of amplification, in plug-in interchangeable units specifically designed for pressure transducer outputs; heart sounds; ECG, EEG potentials; heart and respiration rate transducers; pH electrodes;

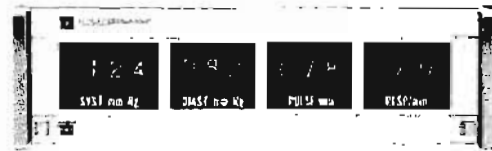
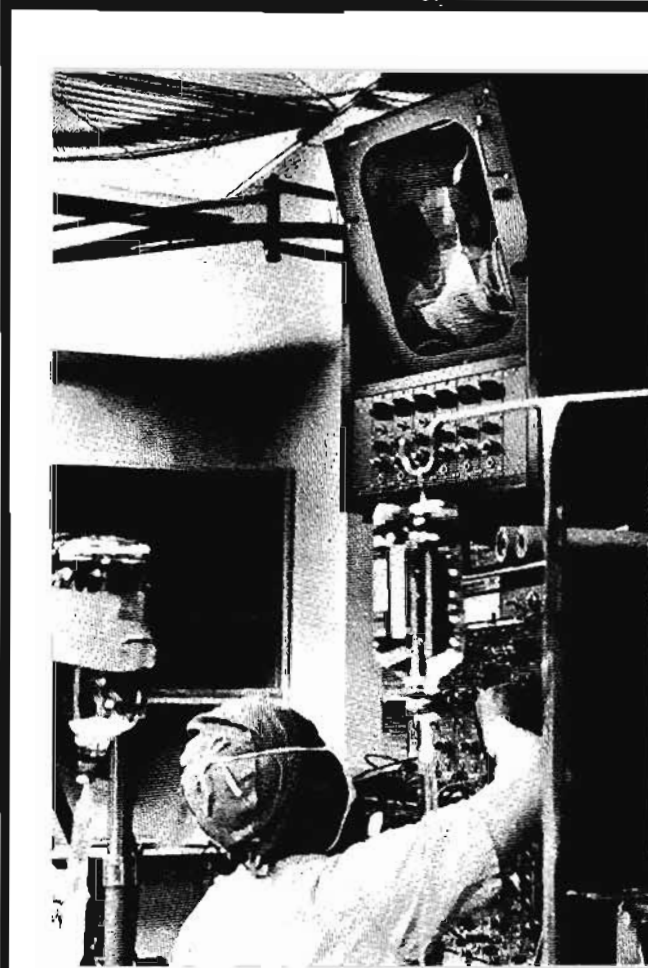

5601A

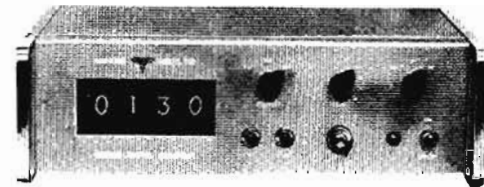

130

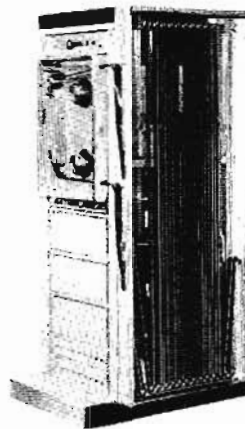

3900B



7734A

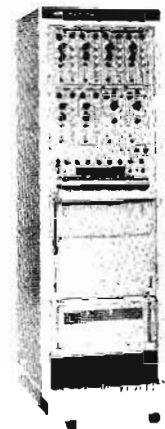

7718A



## OPERATING ROOM SYSTEMS

Systems engineering approach  
Recording and display instruments



**PATIENT MONITORING -  
OPERATING ROOM**

thermistor temperature probe and other low-level outputs. Two different series of these signal conditioners are offered, with eight models in one series and 12 in the second. Typically they are located above the recorder in an oscillograph, as shown below, but they can be positioned anywhere in the system and used as unit amplifiers as well. *Visual display* instruments include single- and multi-channel oscilloscopes, image-retaining scopes, a four-channel numerical display for slowly-changing events (shown below), and large-scale panel meters. Oscillographs for *graphic chart recordings* are exemplified by the thermal- and optical-writing models shown below. Heated-stylus types for dc to 150 Hz phenomena are available in 1- to 8-channel models, with vertical or horizontal chart plane, and with large-screen monitoring scopes built-in, if desired. Optical systems include dc to 500 Hz photographic recorders with rapid developer units, and dc to 5 kHz ultraviolet recorders in 1- to 24-channel capacities.

For data storage and playback in a variety of modes, HP magnetic tape recording/reproducing systems allow the user to equip his system with precisely the number of direct or FM channels he needs from one to 14, a voice channel

for spoken commentary, and valuable options such as an endless-loop device for repetitive playback, remote control unit, system packaging in portable cases for greater mobility, etc. Conformance of system specifications to established IRIG standards also means that tapes may be used by other hospitals and research centers equipped with IRIG standard systems. Other functional elements of an OR monitoring system, which Hewlett-Packard/Sanborn has experience in providing, include inter-communication systems for OR staff, system operator and observers; dye curve integrator for cardiac output determination; vector-cardiograph display/photography units.

In planning a modest or comprehensive OR monitoring system, for either general or specialized surgical procedures, Hewlett-Packard uses a true systems-engineering approach: compatibility of performance and readout of each unit in relation to all other units is given major attention, as well as realistic recognition of actual operating conditions, degree of operator skill required, servicing and maintenance without disruption of the entire system, and positive safety for patient and medical staff alike. For a detailed system proposal with cost estimate, call your Hewlett-Packard field sales office to discuss your requirements.

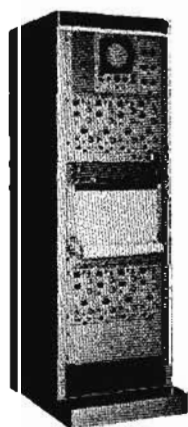
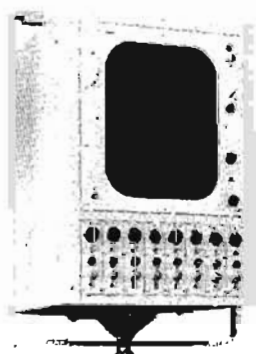

7719A

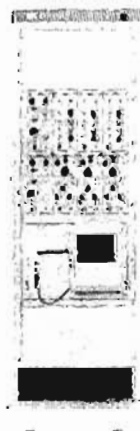

4568B

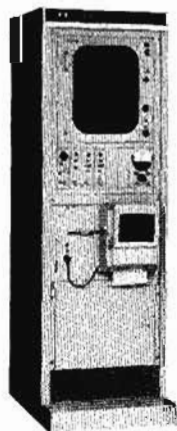

4561B

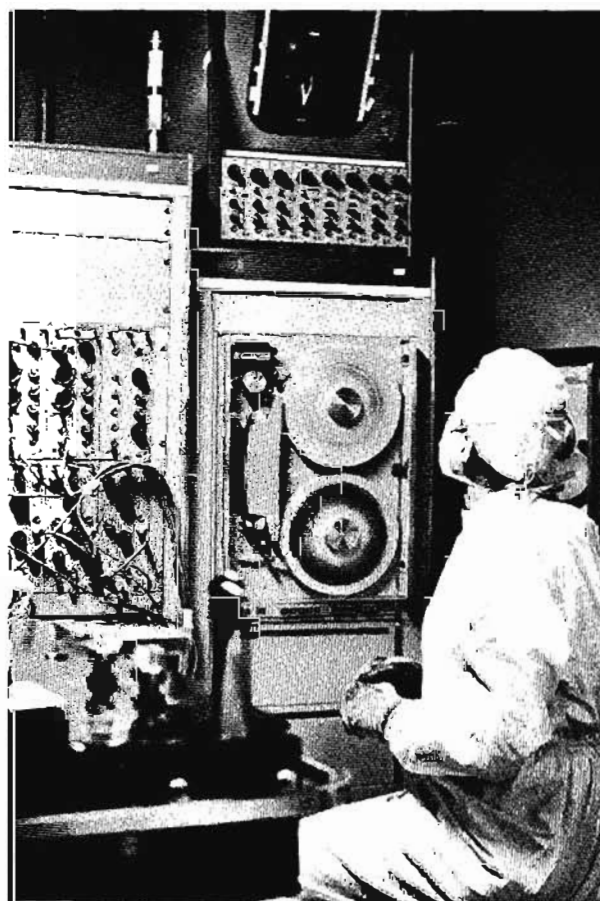



## PATIENT MONITORING - OPERATING ROOM



## MEDICAL TRANSDUCERS

Reliable, accurate, easy-to-use

Models 267, 270, APT, FTA, 1280, 760-53, 350-1700-C10

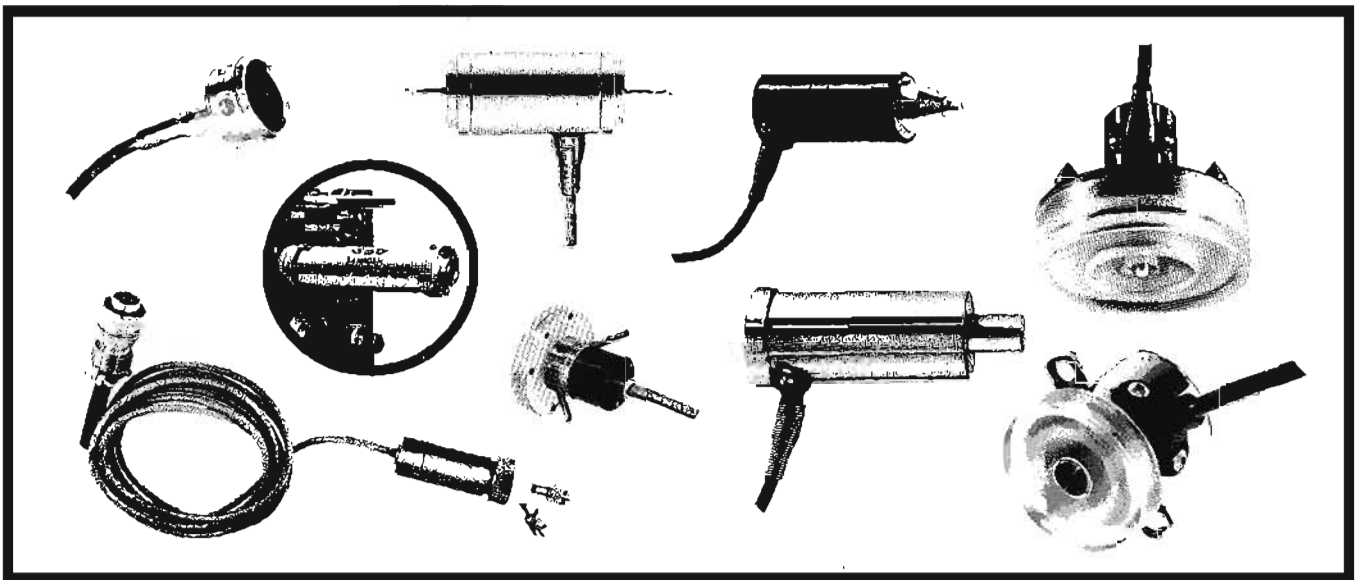

### 267A, 267B, 268A, 268B Pressure Transducers

Compact, sensitive pressure transducers measure gas or fluid pressures, especially for blood pressure, GI and esophageal studies. Models 267B, 268B measure differentially in relation to atmospheric or any other reference pressures,

	Models: 267A, 267B	Models: 268A, 268B
Working range	-100 to +400 mm Hg	-40 to +40 mm Hg
Sensitivity	1 cm/1 mm Hg	1 cm/0.1 mm Hg
Volume displacement	0.04 mm <sup>3</sup> /100 mm Hg	0.4 mm <sup>3</sup> /100 mm Hg
Frequency response	The response of a transducer system depends on the diameter and length of needle and/or catheter, the connecting hardware, the internal volume, volume displacement, and the pressure medium.	
Maximum Pressure	750 mm Hg	300 mm Hg
Internal volume	0.2cc.	0.2cc.
Hysteresis and non-linearity	All models, single-ended mode, =1% max. B models, differential mode, =1.5% max.	
Operating temperature	Not over 120 degrees F°.	
Electrical connections	Eight-foot cable to mate with Sanborn Carrier Pre-amplifier, Extension cables available.	
Differential performance	Models, when used for differential measurements, equal static pressures applied to both inputs will produce an output equivalent to less than 0.5% of the applied pressure. A models for single-ended use.	
Recording system carrier Pre-amplifier	150-1100*, 350-1100, CM*, 150-3000, 350-3000C, 760-3000; *Special plug-in harmonic filter furnished without cost.	
Strain gage amplifiers	140, 64-500, 64-500A, 64-500B, (267-400 adapter required).	
Dimensions and connections	Monel body: 1-9/16" wide, 1/2" high, 1" deep (40 x 38 x 25 mm). Female Luer locks extend 3/8" (10 mm) from four sides of body. Cable coupling extends 1-1/6" (27 mm) beyond body.	
Weight	Transducer net 9 oz (0, 1 kg), unit net 15.5 oz (0,4 kg), shipping 1 lb (0,4 kg)	
Price	267A, \$225; 267B, \$250; 268A, \$225; 268B, \$250; 267-400, \$70	

have sensitivities in each two chambers maintained within 0.5%. Each pressure chamber has an inlet and outlet for bubble-flushing. All pressure-exposed parts are of corrosion-resistant Monel. All units have standard Luer taper twist-lock connectors. Both single-ended and differential models are available in two sensitivities: 1cm/1mmHg and 1cm/0.1mmHg. Electrical connection to Carrier Pre-amplifier is by 8-foot cable (supplied). (Optional extension cable lengths are available; consult a Hewlett-Packard sales office for further details.)

### 350-1700-C10 Contact Crystal Microphone

Reproduces all heart sounds from low pitch rumbles to high-pitch murmurs at frequencies up to 1,000 Hz. Used with Model 350-1700B Heart Sound Pre-amplifier. Shipping weight: 2 lbs. Price: \$56.

### APT-10-1, -11-1, -13, -16 Applanation Pressure Transducers

The APT series transducers measure internal fluid pressure through contact with the surface of a flexible membrane. All APT transducers have a cylindrical guard ring which extends down over a spring-restrained plunger rod, which comprise the probe end. The face of the ring and plunger are in the same plane. In use, the ring and plunger flatten the skin or membrane surface; then internal pressure through the membrane displaces the plunger relative to the plane of the guard ring.

The APT Series is compatible with appropriate Sanborn preamplifiers in Hewlett-Packard/Sanborn direct-writing, photographic recording, meter and scope readout systems.

Model APT-10-1 transducer is a hand-held unit designed to measure such physiologic phenomena as ocular and/or augmented ocular pressure. Model APT-11-1 may be used

## MEDICAL TRANSDUCERS

Reliable, accurate, easy-to-use

Models 267, 270, APT, FTA, 1280, 760-53, 350-1700-C10



**PATIENT MONITORING-  
OPERATING ROOM**

to measure intra-amniotic pressure, or pressure in other body cavities where skin or membrane surface will accommodate the two-inch (50, 8 mm) diameter guard ring and the one-inch (25, 4 mm) diameter plunger.

The hand-held Model APT-13 has a 9.5 mm diameter guard ring encircling a 4.5 mm diameter plunger for measurement of carotid artery pulse waveforms, wrist artery pulse waveforms and other locations. The sensitivity (1 div/2 mm Hg) permits clear traces on an HP/Sanborn ECG Recorder. It can also be used with Low-Level or DC Preamplifiers in recording systems. The APT-13 and APT-16 are "dc in-dc out" units which require a 6-volt power supply. Model APT-16 is also designed to measure pulse waves.

	APT-10-1	APT-11-1	APT-13	APT-16
Pressure range	0-300mmHg	0-150mmHg	0-180mmHg	0-180mmHg
Sensitivity	1 div/mmHg on appropriate Sanborn Recorders.	1 div/mmHg on appropriate Sanborn Recorders.	0.74 mV dc /mmHg with 6 V dc excitation.	1.5 mV dc /mmHg with 6 V dc excitation.
Natural frequency in air	400 Hz	670 Hz	300 Hz	300 Hz
Compliance	0.24 micron /mmHg	1.8 micron /mmHg	0.54 micron /mmHg	1.1 micron /mmHg
Recommended Excitation	5 V @ 2.4 kHz	5 V @ 2.4 kHz	5 V dc @ 20 mA	6 V dc @ 20 mA
Dimensions diameter length	.875" (22, 2 mm) 2.7" (68, 6 mm)	2.0" (50,8)	1.0 (25,4) 2.68" (68, 1)	1.06" (26, 9) .96 (24,4)
Weight	8 oz. (0,6 kg)	8 oz. (0,6 kg)	8 oz. (0,6 kg)	8 oz. (0,6 kg)
Price	\$200	\$265	\$240	\$220
	T41-18 power supply, \$80. TPS-10 portable power supply, \$42			

It has a 25.4 mm diameter guard ring and 6.4 mm diameter plunger and can be easily strapped to the body. The Model T41-18 is a 6-volt battery power supply with appropriate connectors.

### 1280 Series

The 1280 Series transducers are designed for measurement of fluid pressures. They feature a transparent dome and small volume displacement. They are sensitive, compact units suited for measurement of blood pressure, esophageal, and gastro-intestinal phenomena. Single-ended with male Linden pressure connectors.

### Specifications

**Linear range:** — 100 to 400 mm Hg.

**Overload:** — 100 to 750 mm Hg (max.).

**Sensitivity:** 4 mV/Vx/100 mm Hg.

**Sensor:** bridge-type, not compatible with 150-3000, 350-3000 preamplifiers.

**Input Impedance:** 130 ohms.

**Output Impedance:** 100 + j50.

**Excitation:** 5 vac (max.), 2.4 kHz.

**Allnearity:** 0.5%.

**Temperature range:** +40° to +130°F.

**Natural frequency:** greater than 2 kHz in air.

**Volume (Internal):** 0.28 cc (dome only).

**Volume displacement:** .04 mm<sup>3</sup>/100 m Hg.

**Weight:** net 29 oz (0,4 kg); shipping 1.1 lbs (0,5 kg).

**Dimensions:** 4.35" long (110 mm), 1.19" (30.2 mm) dia.

**Price:** on request.

### Linearsyn, 7DCDT, and LVsyn Transducers

Linearsyn and 7DCDT differential transformer transducers are used for the measurement of the displacement of muscle, limb, blood vessel, chest wall and other physiological motions. LVsyn models are designed to measure the velocity of these motions.

### Other Transducers

The FTA Series of myographic force transducers is designed primarily for the measurement of isometric muscle contractions. The Model 270 Differential Gas Pressure Transducer is designed for the measurement and recording of relatively low pressure variables, such as in pulmonary studies.

The Calibrated Temperature Bridge, Model 760-53 is an adaptor for use with any Carrier Preamplifier and a variety of interchangeable thermistor probes for accurate recording or monitoring of physiologic temperatures.

**Weight:** net 3 oz (0,03 kg); shipping 1 lb (0,4 kg).

**Price:** \$99.

### Accessories and optional equipment

Model 374 Pulse Wave Attachment with phone plug connector for use with an ECG Preamplifier in an HP/Sanborn recording system, or with an adapter cable for use with the HP/Sanborn Model 100 Viso-Cardiette, is also available. Price: \$71. Adapter Cable (651-114P6): \$4.05. Model 108 Pneumograph Attachment is available for use with the Model 374 for simultaneous or separate pneumogram recordings. Price: \$25. The Model 53 Battery Converter is a solid-state, integral battery charger which provides 128 V ac, 60 cps at 125 watts for 2 hours for use with portable recorders and amplifiers having power requirements from 40 to 125 watts.

Other accessories described in this catalog are: 37P Series Thermistor Probes; 7816 Plethysmograph Pulse Transducer; 780-14 Respiration Transducer; ECG Electrodes; 373 Pulse Wave Transducer.



## SIGNAL CONDITIONERS

Versatility in physiological recording  
Series 350 and 760

Two separate series of Sanborn Physiological Signal Conditioners—Series 350 and Series 760 Preamplifiers—are used in the Sanborn Recording and Monitoring Systems described on pages 64, 65, 66, and 67. The 350's are the most versatile and highly developed of Sanborn interchangeable, plug-in physiological preamplifiers. There are 12 different types available for monitoring and/or recording more than a score of physiological phenomena. The 350 types may also be used as unit amplifiers, independent of the recording system, to drive panel meters, scopes, numerical displays, etc. The 760 types are also interchangeable plug-in units. They are available in fewer models but have the advantage of smaller size, all solid state circuits and, in most cases, lower cost. Whether a system accepts 350 or 760 Preamps the specific preamplifiers selected will depend on the phenomena to be measured as well as on the type of transducer or other measuring equipment used. (The Applications Table suggests suitable signal conditioners for different physiologic variables, the exact selection again depending on the transducer or other measuring equipment used.) Plug-in 350 Preamplifiers weigh approximately 5 pounds (2.3 kg) each and are 10½ inches high by 1-3/16 inches wide by 19 inches deep (including an individual 350-500B Power Supply connected at the rear (267 x 103 x 173 mm)). Transistorized 760 Preamplifiers weigh approximately two pounds (.9 kg) each and measure 7 inches high by 2 inches wide (178 x 51 mm).

The 350-1000B DC Preamplifier with wide bandwidth is suitable for recording output of numerous indicating devices and transducers. It may also be used for recording analog data from tape recorders. \$325

The 350-1100CM Carrier Preamplifier is used for registration of physiological pressures, with any of numerous strain gage, variable reluctance and differential transformer pickups; and for temperature measurements with Sanborn 760-53 Calibrated Temperature Bridge. Other phenomena, such as force, stress, displacement, velocity, flow, vibration and acceleration may be measured with the 350-1100CM and appropriate transducers. The Model 350-1100CM has a harmonic filter installed for use with Model 267 and 268 Sanborn Transducers. \$425.

The Model 350-1300C DC Preamplifier is a moderate gain, three-stage dc amplifier, featuring two gain stages and a cathode follower output. It may be used for recording the output of such laboratory instruments as gas analyzers, densitometers, cardiometers, and magnetic tape recorders. It may also be used for recording dc signals directly from certain transducers. \$250

The 350-1500A Low Level Preamplifier offers 8 interchangeable plug-in front-ends, making the preamplifier a practical choice for flexibility in low level measurement and recording. Plug-in front-ends include Model 350-2B a general purpose dc amplifier with zero suppression, Model 350-3A EEG-ECG Plug-in, Model 350-4A Strain Gage Plug-in for operation of strain gage bridges in the 100-1000 ohm impedance range, Model 350-8 Waters Oximeter (monitor), Model 350-9A Waters Earpiece/Cuvette (direct), Model 350-11A Oxygen Cell, Model 350-12 Galvanic Skin Resistance Plug-in, and Model 350-15 Thermal Dilution Plug-in. Price 350-1500A, \$525; 350-2B, \$190; 350-3A, \$225; 350-4A, \$130; 350-8, \$175; 350-9A, \$200; 350-11A, \$140; 350-12, \$205; 350-15, \$265

The Model 350-1700C Heart Sound Preamplifier is designed

### Applications

Physiologic variable	Applicable Preamplifiers	
	Model 350-	Model 760-
Apex cardiogram	3200A or 2700C	
Ballistocardiogram	1500A w/350-2; 3200A or 2700C	1600A
Compliance (lung)	5000B	
Dye curve	1000B; 1300C; 2700C or 3200A	1300
ECG (adult, child, large and small animal)	3200A or 2700C	1600A
Electromyograms	3200A or 2700C	1600A or 2700A
Electroretinogram	2700C	2700A
Fetal ECG	2700C or 1500A w/350-3A	2700A
Flow, air	1100CM or 3000C	3000
Flow, blood	1000B; 1300C; 3200A or 2700C	1300
Galvanic skin resistance (GSR)	1500A w/350-12	760-1500 w/350-12
Gas analysis (carbon monox., carbon diox., nitrogen)	1000B; 1300C; 2700C or 3200A	1300
Heart Rate	3400A	3A
Heart shunt detection	1500A w/350-11A	760-1500w/350-11A
Heart sound	1700C	
Heart sound timing	3200A or 2700C	

Physiologic variable	Applicable preamplifiers	
	Model 350-	Model 760-
Oximetry (oxygen saturation)	1500A w/350-9A	760-1500 w/350-9A
pCO <sub>2</sub>	3600A	
pH	3600A	
Pneumogram	3200A or 2700C	
pO <sub>2</sub>	1500A w/350-11A or 3600A+adapter	1500 w/350-11A
Plethysmogram, limb-digit	1100CM; 3200A or 2700C	3000 or 1600A
Plethysmogram, body	1100B or 3000B	3000
Pressure (direct)—arterial, esophageal, GI, spinal, venous	1100CM or 3000C	3000
Pulse wave	3200A or 2700C	1600A
Resistance, total pulmonary	5000B	
Respiration rate		2200
Scalar VCG	one to three 2700C's	
Temperature	1100CM; 3000C or 1500A w/350-2B	3000
Thermal-dilution	1500A	
Vectorcardiogram	(2) 2700C	
Volume, respiratory	3700A	

## SIGNAL CONDITIONERS

Versatility in physiological recording  
Series 350 and 760



# RESEARCH

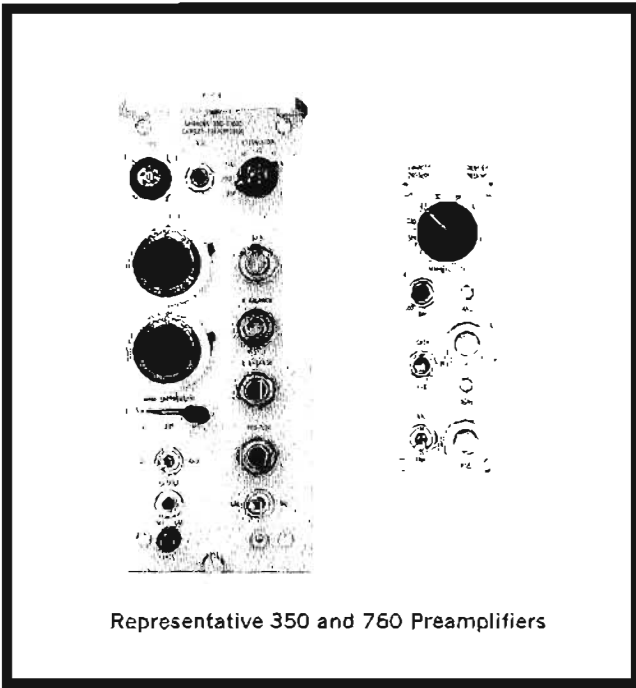

Representative 350 and 760 Preamplifiers

to be used with the Sanborn Poly Beam Recorders (or other optical recorders having 500 Hz galvanometers) for electrical auscultation and the registration of diagnostic phonocardiograms. Additionally this preamplifier may be used externally with a 350-500B Power Supply and a 450 style portable case as an Amplifying Stethoscope. \$275

The 350-2700C High Gain Preamplifier is useful for single channel EEG work such as monitoring anesthesia level or the level of oxygen provided by an oxygenator during open heart surgery, for fetal ECG's, for small muscle myography, and for nerve potential and muscle tissue measurements. In addition, it provides lead selection for routine ECG's. A dc input jack permits recording the same functions as the 350-1300C and the dc section of the 350-3200A. It is also useful for vectorcardiography. \$375

The 350-3000C Medical Carrier is designed for use with Sanborn Physiological Pressure Transducers (Model 267 and 268 for the determination of pressure with respect to atmospheric pressure or the difference between two applied pressures, and the Model 270, a high sensitivity differential pressure gas transducer). The 350-3000C is also useable with the 760-53 Calibrated Temperature Bridge and with Sanborn Force Transducers. \$325

The 350-3200A ECG/General Preamplifier provides accurate, diagnostic ECG's. Up to four 350-3200A's may be used in multi-channel systems equipped with ECG input facilities. The dc section of the preamplifier is suitable for recording the output of indicating devices used in gas analysis and dye dilution studies. The ac section will accept the output of the Sanborn 374 Pulse Wave Attachment, the 108 Pneumograph Attachment, certain Ballistocardiographs, and transducer outputs with pp signals from 5 to 200 mV full scale. \$325

The 350-3400A Cardio-Tach Preamplifier may be used for measuring either average heart rate or the time interval between consecutive R-waves. Readout of average rate may be made on

a recorder, the 760-20 Monitor Meter, or the 760-5 and -6 Threshold Monitor and Alarm Box. Readout of the time interval output — a ramp voltage function in which maximum amplitude is proportional to the time between the two previous R-waves — may be on a recorder or oscilloscope. \$550

The 350-3600A pH Preamplifier may be used in Sanborn multi-channel systems to provide precise, intermittent graphic measurement of pH or pCO<sub>2</sub> changes in samples of blood or other biological solutions. When packaged in a portable 450 case it serves as an independent meter for the measurement of pH or pCO<sub>2</sub> in whole blood and for general purpose pH measurements in the 3 to 11 pH range. \$650

The 350-3700A Integrating Preamplifier is designed to integrate or summate the output of 350 Preamplifiers or certain transducers. In the integration mode, the preamplifier performs as a low pass RC filter with a time constant of 2000 seconds, followed by a high gain chopper amplifier. As an area summator, the areas under the positive input signals are added. When the output is connected to a recorder, the results indicate precisely the rate and amount of activity that occur over a given period of time. Typical applications are found in electromyography and pulmonary function studies. \$450

The 350-5000B Respiratory Preamplifier — used in conjunction with other 350 style preamplifiers — performs the integration of flow resulting in an electrical signal equivalent to the volume change of the lungs. Electrical signals related to flow of air into and out of the lungs, the volume change of the lungs, and the total pressure across the lungs are presented on an oscilloscope in loop form. \$550

The 760-1300 DC Coupler performs the same functions as the 350-1300C. \$135

The 760-1500 Low Level Preamplifier is a chopper type dc preamp for monitoring low level signals, such as those derived from thermocouples, photocells, oxygen electrodes, oximeters, thermistors, strain gage bridges and dye dilution equipment. In some applications, an input coupler may be required. Available input couplers include the 350-9A Waters Earpiece/Cuvette, the 350-11A Oxygen Cell and the 350-12 Galvanic Skin Resistance Plug-in. \$300

The 760-1600A ECG Preamplifier permits monitoring ECG bipolar leads (Leads 1, 2, 3). It may be used with 760-3 Cardio-tach to monitor heart rate. \$225

The 760-2200 Respiration Rate Preamplifier is designed to produce a dc voltage at the output directly proportional to average respiration rate. The input signal comes from a respiration transducer, or the output of a 350 or 760 Carrier Amplifier which derives its signal from a pneumotach screen and pressure transducer. \$400

The Model 760-2700A EEG Preamplifier is similar in function and purpose to the 350-2700C High Gain Preamplifier. \$200

The Model 760-3000 Carrier Preamplifier corresponds in function and purpose to the 350-3000C Medical Carrier. \$175

The Model 760-3100 Pressure Processor is designed for monitoring systolic, diastolic, and mean arterial blood pressures. It is used in conjunction with the 760-3000 Carrier which obtains its input from blood pressure via a Sanborn Pressure Transducer or strain gage type pressure transducer. \$500

The 760-3 Cardio-tach produces a dc voltage at the output directly proportional to average heart rate. The heart rate may be obtained from any one of 3 different signal sources: 1) R-wave in the ECG waveform (760-1600A); 2) arterial pressure pulse (760-3000), ear plethysmograph (780-16). \$300



## OSCILLOGRAPH RECORDING

Instantaneous, permanent, rectilinear  
7700 Series

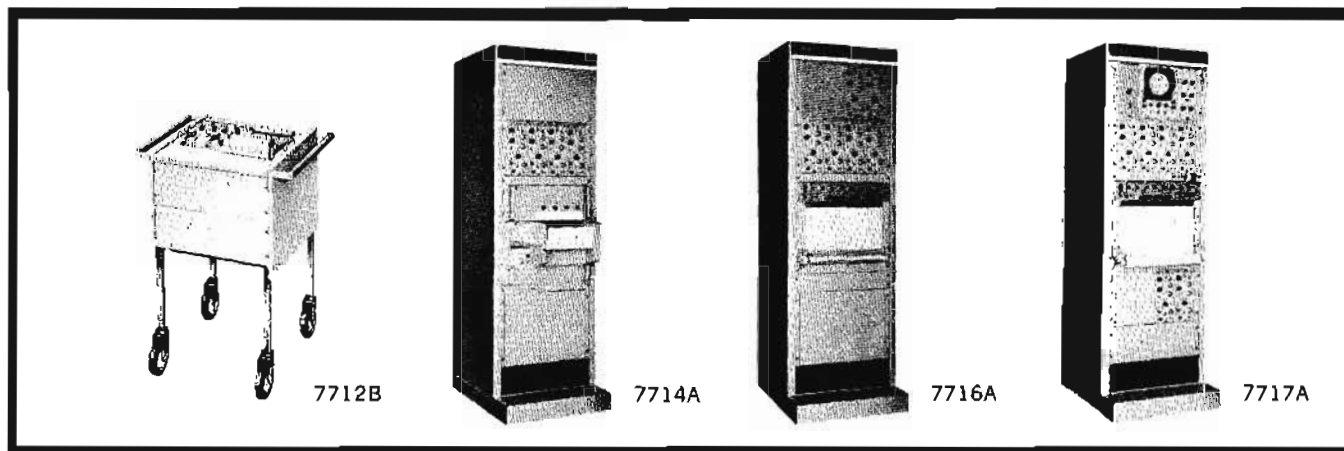

### 7712B Two channel recording system

The 7712B two channel thermal recording system features mobile cart mounting, for wheeling the system to the point of measurement. This facilitates clinical and research applications of the system, with any two of the "350" series of plug-in preamplifiers. Pushbuttons select 2.5, 5, 25 and 50 mm/sec speeds. Recording channels are 50-mm wide, with a recorded frequency response from dc to 125 Hz unless limited by the preamplifier.

**Power requirements:** 115 V, 60 Hz, 200 watts.

**Overall size:** 14" high, 19" wide, 17 $\frac{1}{4}$ " deep (356 x 483 x 438 mm).

**Weight:** net 130 lbs (58,5 kg); shipping 172 lbs (77,2 kg).

**Price:** HP Model 7712B, \$1970. Model 7712-01A Recorder (for rack mounting), \$1775.

### 7714A Four channel recording system

The 7714A four channel thermal recording system for use with any four "350" series plug-in preamplifiers is complete in its fully enclosed upright cabinet. The system features a horizontal chart table, for easier notation on the recording. The four recording channels, each 50-mm wide, provide a recording response from dc to 125 Hz unless limited by the preamplifier. Mechanically selected chart drive speeds are 0.25, 0.5, 1, 2.5, 5, 10, 25, 50, and 100 mm/sec.

**Power requirements:** 115 V, 60 Hz, 350 watts.

**Overall size:** 72 $\frac{1}{8}$ " high, 22-1/16" wide, 30" deep (1832 x 560 x 762 mm).

**Weight:** net 473 lbs (214 kg); shipping 569 lbs (256 kg).

**Price:** HP Model 7714A, \$3970.

Option 01: less cabinet; requires adequate cooling; price \$3695. Option 06: ECG input facility; for cabinet use only; add \$200. Option 07: visual display facility; for 569B Scope; for cabinet use only; add \$150. Option 08: 50 Hz operation; no extra charge. Option 09: adds 230 volt transformer 66A-10; specify in cabinet or loose; add \$100. Option 12: less one channel; deduct \$200. Option 13: add slides for 780-6A Scope; add \$25. Option 14: with 8-channel signal cable for 780-6A Option 01; add \$50.

### 7716A Six channel recording system

The 7716A six channel thermal recording system is designed to operate with any six of the "350" series of plug-in

preamplifiers as a single cabinet-mounted system. The system features a flush-front recording drive, to allow observation of the recording as it is being made. The six recording channels, each 50-mm wide, record from dc to 125 Hz unless limited by the preamplifier. Electrically selected speeds by pushbutton are 0.25, 0.5, 1, 2.5, 5, 10, 25, 50, and 100 mm/sec.

**Power requirements:** 115 V, 60 Hz, 900 watts.

**Overall size:** 72 $\frac{1}{8}$ " high, 22-1/16" wide, 30" deep (1832 x 560 x 762 mm).

**Weight:** net 574 lbs (259 kg); shipping 670 lbs (302 kg).

**Price:** HP Model 7716A, \$5325.

Option 01: less cabinet; requires adequate cooling; price \$4950. Option 02: for portable cases; price \$5383. Option 06: ECG input facility; add \$200. Option 08: 50 Hz operation; no extra charge. Option 09: adds 230 volt transformer 66A-10; specify in cabinet or loose; add \$100. Option 11: adds mm/min. speeds; recorder 356-100DW; add \$250. Option 12: less one channel; deduct \$200.

### 7717A Six channel recording system

The 7717A six channel thermal recording system features a visual display facility for single or multi-channel display, as a unified system complete in one upright cabinet. The system operates with any six of the "350" series of plug-in preamplifiers. Each recording channel is 50-mm wide, and provides a response from dc to 125 Hz unless limited by the preamplifier. Electrically selected speeds by pushbutton are 0.25, 0.5, 1, 2.5, 5, 10, 25, 50, and 100 mm/sec.

**Power requirements:** 115 V, 60 Hz, 970 watts.

**Overall size:** 72 $\frac{1}{8}$ " high, 22-1/16" wide, 30" deep (1832 x 560 x 762 mm).

**Weight:** net 590 lbs (266 kg); shipping 686 lbs (309 kg).

**Price:** HP Model 7717A, \$5475.

Option 06: ECG input facility; add \$200. Option 07: scope mounting facility for 569B; cabinet use only; no extra charge. Option 09: add 230 volt transformer 66A-10; specify in cabinet or loose; add \$100. Option 11: add mm/min speeds; recorder 356-100DW; add \$250. Option 12: less one channel; deduct \$200. Option 13: 780-6A Scope mounting facility; deduct \$125. Option 14: 8-channel signal cable for 780-6A Option 01; add \$50.

# OSCILLOGRAPH RECORDING

Instantaneous, permanent, rectilinear  
7700 Series



## RESEARCH

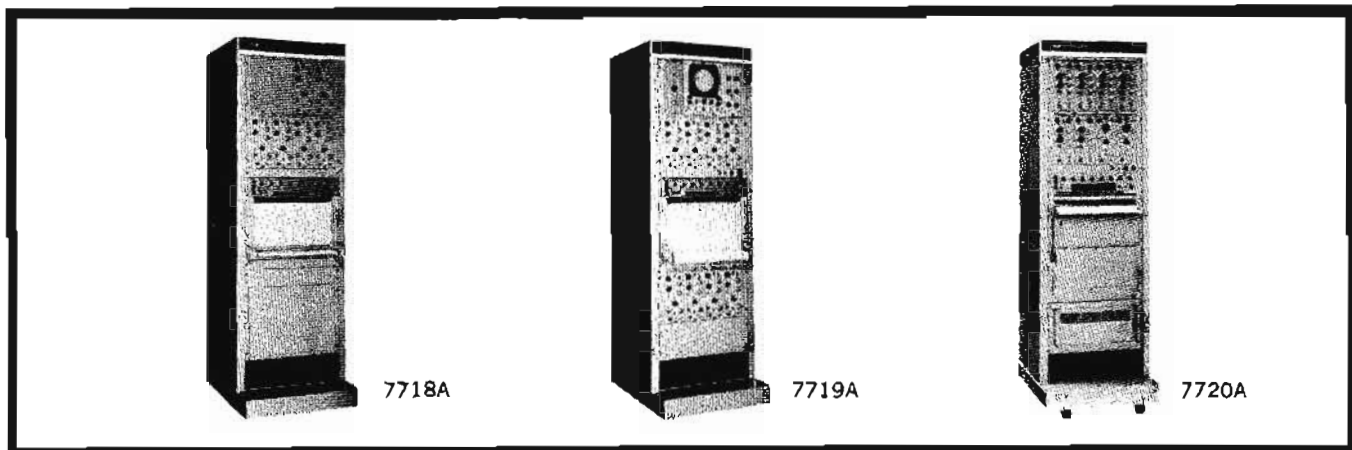

### 7718A Eight channel recording system

The 7718A eight channel thermal recording system provides the advantages of eight recording channels on one chart, with a wide response from dc to 150 Hz unless limited by the preamplifiers. This provides a maximum of recording facilities, which adds flexibility to both clinical and research applications, and furnishes a maximum amount of recorded data for any one observation. The eight recording channels are each 40 mm wide, divided into 50 divisions. The system operates with any eight of the "350" series of plug-in preamplifiers. Electrically selected speeds by pushbutton are 0.25, 0.5, 1, 2.5, 5, 10, 25, 50, and 100 mm/sec.

**Power requirements:** 115 V, 60 Hz, 950 watts.

**Overall size:** 72 $\frac{1}{8}$ " high, 22-1/16" wide, 30" deep (1832 x 560 x 762 mm).

**Weight:** net 532 lbs (240 kg); shipping 628 lbs (283 kg).

**Price:** HP Model 7718A, \$6350.

Option 01: less cabinet; requires adequate cooling; price \$5975. Option 02: in portable cases; price \$6350. Option 06: ECG input facility; add \$200. Option 08: 50 Hz operation; no extra charge. Option 09: add 230 volt transformer 66A-10; specify in cabinet or loose; add \$100. Option 11: add mm/min speeds; recorder 358-100D; add \$250. Option 12: less one channel; deduct \$200.

### 7719A Eight channel recording system

The 7719A eight channel thermal recording system features a visual display facility as a standard part of the completed system. This facility is designed around a cathode ray oscilloscope, and may be used for the display of vectorcardiographic loops, or for showing other physiological phenomena such as ECG, EEG, pulse waves, etc. The entire system is complete in one upright cabinet, and includes provisions for inserting any selection of eight "350" series plug-in preamplifiers. Each of the eight recording channels is 40 mm wide, divided into 50 divisions, with a recorded frequency response from dc to 150 Hz unless limited by the preamplifier. Electrically selected speeds by pushbutton are 0.25, 0.5, 1, 2.5, 5, 10, 25, 50, and 100 mm/sec.

**Power requirements:** 115 V, 60 Hz, 950 watts.

**Overall size:** 72 $\frac{1}{8}$ " high, 22-1/16" wide, 30" deep (1832 x 560 x 762 mm).

**Weight:** net 532 lbs (240 kg); shipping 628 lbs (283 kg).

**Price:** HP Model 7719A, \$6500.

Option 06: add ECG input facility; add \$200. Option 07: scope mounting facility for 569B; cabinet use only; no extra charge. Option 08: 50 Hz operation; no extra charge. Option 09: add 230 volt transformer 66A-10, specify in cabinet or loose; add \$100. Option 11: add mm/min speeds; recorder 358-100D; add \$250. Option 12: less one channel deduct \$250. Option 13: 780-6A scope mounting facility; deduct \$125. Option 14: 8-channel signal cable for 780-6A Option 01; add \$50.

### 7720A Eight channel recording system

The 7720A eight channel thermal recording system operates with any eight "350" preamplifiers. The system features a horizontal chart table, for easier notation on the recording. Multi-channel recording furnishes a maximum amount of information on the chart for clinical or research measurements. Recording channels are 40 mm wide, 50 divisions, with a recorded response from dc to 125 Hz, unless limited by the preamplifier. Mechanically selected chart speeds are 0.25, 0.5, 1, 2.5, 5, 10, 25, 50, and 100 mm/sec.

**Power requirements:** 115 V, 60 Hz, 950 watts.

**Overall size:** 72 $\frac{1}{8}$ " high, 22-1/16" wide, 30" deep (1832 x 560 x 762 mm).

**Weight:** net 532 lbs (240 kg); shipping 628 lbs (283 kg).

**Price:** HP Model 7720A, \$6650.

**Also available:** 7721A, six channel; price \$5620. 7722A, eight channel, with visual display; price \$6900. 7723A, six channels, with visual display; price \$5870.

Option 06: ECG input facility; add \$200. Option 08: 50 Hz operation; no extra charge. Option 09: add 230 volt transformer 66A-10; specify in cabinet or loose; add \$100. Option 12: less one channel; deduct \$200.

For 7722A, 7723A only: Option 07: scope mounting facility for 569B; cabinet use only; no extra charge. Option 13: 780-6A scope mounting facility; deduct \$125. Option 14: 8-channel signal cable for 780-6A Option 01; add \$50. Option 06 and 07 cannot be used together.





## OSCILLOGRAPHIC RECORDING

Versatile, reliable, wide range

7700, 4500 Series

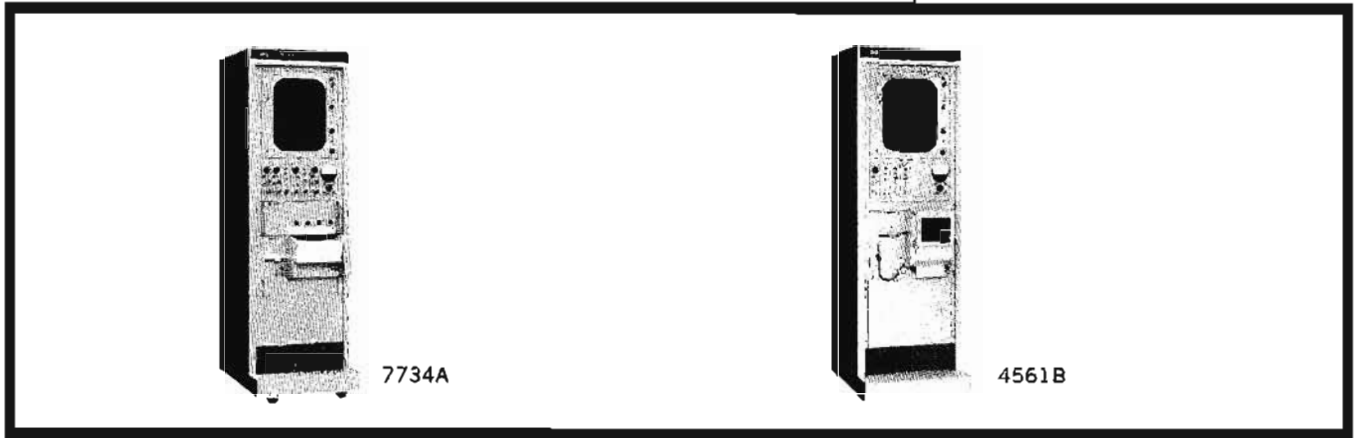

### 7734A Monitor recording systems

The 7734A system features both a complete multi-channel oscilloscope for data presentation, and a four-channel thermal recorder for making a permanent record of the data. The oscilloscope at the upper part of the cabinet presents four simultaneous channels of physiologic data on its 13 $\frac{1}{2}$ " x 10" (viewing size) cathode ray tube screen, for applications such as at-a-glance observation of a patient's condition, or for monitoring the status of a research project. Sweep speeds are 3, 6 and 12 mm/sec, automatic or manual (plus 30 mm/sec, manual) on the 17" long-persistence cathode ray tube.

The recorder makes a permanent, instantaneous thermal recording on four 50-mm wide recording channels, over a frequency range of dc to 125 Hz, unless limited by the preamplifier. Mechanically-selected chart drive speeds are 0.25, 0.5, 1, 2.5, 5, 10, 25, 50, 100 mm/sec. This frequency range is well matched to most clinical and research measurements of physiologic phenomena. Its use in conjunction with the multi-channel oscilloscope allows observing a lengthy sequence of occurrences and recording only those which are significant, for later measurement, reference, and analysis.

The system uses any six of the "760" series of plug-in preamplifiers or front end units. The output of four preamplifiers appears on the oscilloscope and recorder, leaving two system channels available for display on a meter or other indicator, or for mounting a front end unit.

**Power requirements:** 115 V 60 Hz, 000 watts.

**Overall size:** 72 $\frac{1}{2}$ " high, 22-1/16" wide, 30" deep (1841 x 560 x 762 mm).

**Weight:** net 408 lbs (184 kg); shipping 504 lbs (223 kg).

**Price:** HP 7734A, \$4795.

#### Options

- |   |       |
|---|-------|
| 08 50 Hz operation  | n/c   |
| 09 Adds 230 volt transformer 66A-10; specify in cabinet or loose; add | \$100 |

### 4561B Monitor recording system

The 4561B system features a wide-range four-channel optical recorder (Rapid Developer optional), plus a multi-channel large-screen monitoring oscilloscope. The recorder provides eight manually-selected chart drive speeds in the

range 2.5 to 200 mm/sec (5-100 mm/sec when using the 563 Rapid developer). The bromide recording paper may be 6" wide (200' length) or (with Rapid Developer) 6 cm wide (175' length), with no change required in the instrument. The paper container is loaded in the darkroom, exposed in the recorder under normal room illumination, then developed in the darkroom or automatically at the time of recording by the 563 Rapid Developer. Beams may be superimposed, or each separated into its individual portion of the chart. Amplitude and timing lines are recorded at the same time as the data, with the timing lines being controlled by an independent synchronous motor. Frequency response extends from dc to 500 Hz (other ranges available) unless limited by the preamplifier. This extended frequency response is valuable for studying physiological events such as heart sounds, electromyographic potentials and small animal ECG.

The multi-channel oscilloscope in the upper part of the cabinet is the same as that used in the 7734A system (see left) and provides the same features of operation. The system uses any six "760" preamplifiers or front end units; four preamplifiers display on the oscilloscope or drive a recorder channel, while two channels are reserved for use with other indicators or for front-end units.

**Power requirements:** 115 V 60 Hz, 650 watts (approx.).

**Overall size:** 72 $\frac{1}{2}$ " high, 22-1/16" wide, 30" deep (1841 x 560 x 762 mm).

**Weight:** net 408 lbs (184 kg); shipping 533 lbs (240 kg).

**Price:** HP Model 4561B, \$4580.

#### Options

- |   |       |
|---|-------|
| 08 50 Hz operation  | n/c   |
| 09 Adds 230 volt transformer 66A-10; specify in cabinet or loose; add | \$100 |

### 4564B Photographic recording system

The 4564B photographic recording system features the same optical recorder as is used in the 4561B system, but utilizes the more versatile series of 350 plug-in preamplifiers. These preamplifiers permit recording an extensive range of physiological phenomena, at a frequency range from dc to 500 Hz, or as limited by the preamplifier (to 1 kHz with 350-1700C). Rapid Developer 563 (optional) provides the ad-



# OSCILLOGRAPHIC RECORDING

Versatile, reliable, wide range  
7700, 4500 Series



## RESEARCH

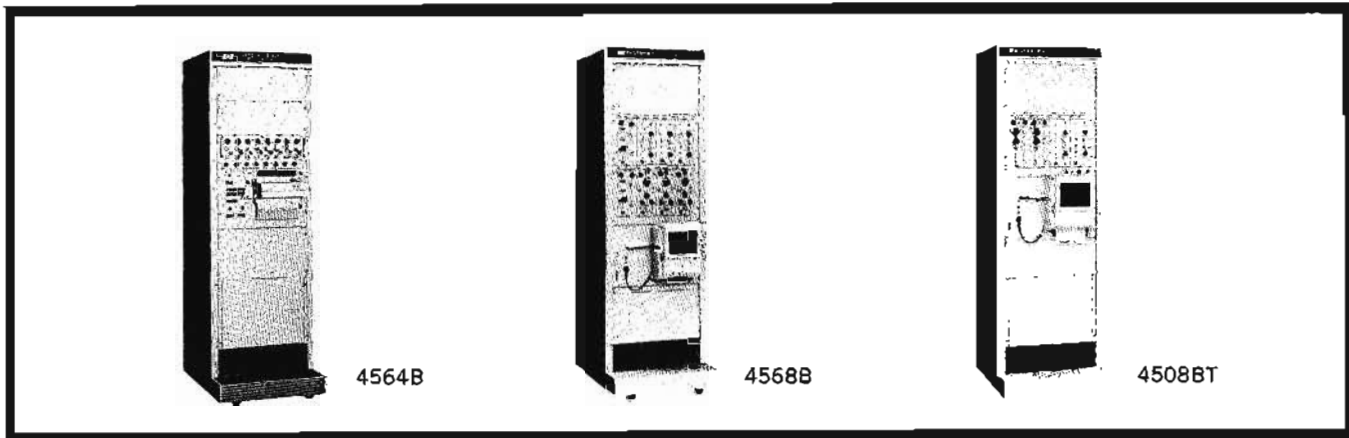

vantages of wide-range optical recording without the delay of darkroom processing before the final recording may be used.

**Power requirements:** 115 V 60 Hz, 700 watts (approx.).

**Overall size:** 72½" high, 22-1/16" wide, 30" deep (1841 x 560 x 762 mm).

**Weight:** net 458 lbs (206 kg); shipping 554 lbs (252 kg).

**Price:** HP Model 4564B, \$3455.

#### Options

06 ECG input facility; add	\$200
07 Visual display facility; for 569B scope; for cabinet use only; add	\$150
08 50 Hz operation	n/c
09 Adds 230 volt transformer 66A-10; specify in cabinet or loose; add	\$100
13 Add slides for 780-6A scope; add	\$ 25
14 With 8-channel signal cable for 780-6 Option 01; add	\$ 50

#### 4568B Photographic recording system

The 4568B photographic recording system features the same optical photographic recorder as used in the 4561B and 4564B systems, operating with any eight of the "350" series of plug-in preamplifiers, to provide eight separate or overlapping channels of wide-range data recording. Use of all eight channels provides a thorough presentation of physiologic events and their waveforms, as they may occur in clinical investigation of a patient, or in research-oriented experimentation on a subject. The wide frequency range of the recording, which extends from dc to 500 Hz unless limited by the preamplifier (to 1 kHz with 350-1700C) permits extensive small-animal investigation, as well as routine recording of such high frequency variables as heart sounds and electromyographic potentials. Other ranges available on order.

**Power requirements:** 115 V, 60 Hz, 1000 watts (approx.).

**Overall size:** 72½" high, 22-1/16" wide, 30" deep (1841 x 560 x 762 mm).

**Weight:** net 456 lbs (206 kg); shipping 552 lbs (248 kg).

**Price:** HP Model 4568B, \$5160.

#### Options

06 ECG input facility; add	\$200
07 Visual display facility; for 569B scope; for cabinet use only; add	\$150
08 50 Hz operation	n/c
09 Adds 230 volt transformer 66A-10; specify in cabinet or loose; add	\$100
13 Add slides for 780-6A scope; add	\$ 25
14 With 8-channel signal cable for 780-6A Option 01; add	\$ 50

#### 4508BT Ultra-violet recording system

The 4508BT system features a special ultra-violet sensitive recording paper whose latent image may be developed simply by exposure to fluorescent illumination. The chart paper roll may be loaded under normal room lighting, and is developed by the built-in post-exposure fluorescent lamp, so the multi-channel data may be viewed a few seconds after it is recorded. The system uses any eight of the "350" series preamplifiers, for a recorded frequency response from dc to 500 Hz (to 1 kHz with 350-1700C) unless limited by the preamplifier. The recorder provides nine pushbutton selected speeds in the range of 2.5 to 1000 mm/sec. Data channels may be separate, or may overlap to the full width of the eight-inch chart. Time and amplitude lines are recorded with the data, for maximum accuracy.

**Power requirements:** 115 V, 60 Hz, 1600 watts (approx.).

**Overall size:** 72½" high, 22-1/16" wide, 30" deep (1841 x 560 x 762 mm).

**Weight:** net 19 lbs (85,5 kg); shipping 250 lbs (113 kg).

**Price:** HP Model 4805BT, \$7100.

#### Options

06 ECG input facility; add	\$200
07 Visual display facility; for 569B scopes; for cabinet use only; add	\$150
08 50 Hz operation	n/c
09 Adds 230 volt transformer 66A-10; specify in cabinet or loose; add	\$100
13 Add slides for 780-6A scope; add	\$ 25
14 With 8-channel signal cable for 780-6A Option 01; add	\$ 50

RESEARCH

hp

## MAGNETIC TAPE RECORDING

High performance, moderate cost, compatible  
Models 3907B, 3914B, 3917B, 3924B

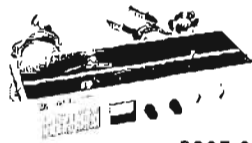

3907-06A  
Voice Channel Amplifier

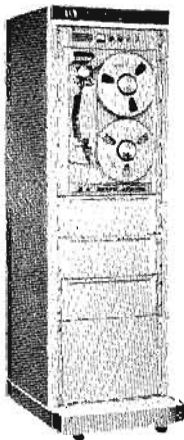

3900 Series  
Vertical  
Mobile  
Cabinet

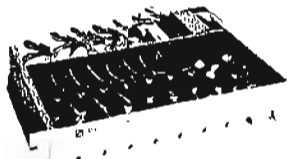

3907-07A  
Input Coupling Amplifier

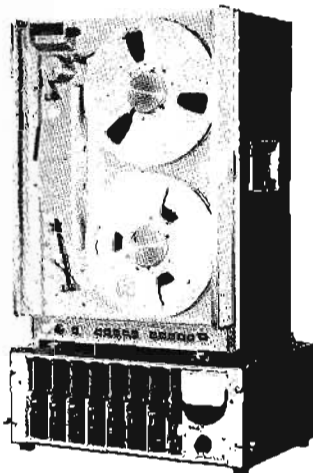

3907B Option 02  
Portable Cases  
For Transport  
And Amplifiers

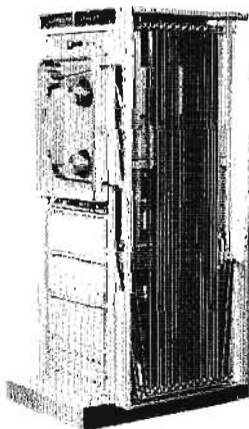

3907-04B Tape Loop Adapter



3907-11A  
Remote  
Control Unit

**System Choices—Performance Features** Sanborn 3900-series magnetic tape record/reproduce systems are available with 7 or 14 analog data recording channels, plus an optional edge-channel for recording voice commentary, 6 standard speeds from  $1\frac{7}{8}$  ips to 60 ips, with user's choice of plug-in circuit cards for direct, FM or pulse-mode recording. Narrow bandwidth systems (3907B, 3914B) have a max. frequency response in direct mode of 100 kHz; intermediate bandwidth systems (3917B, 3924B), response to 250 kHz max. As shown at left, system may be housed in vertical mobile cabinet, or tape transport and electronics packaged in separate portable cases.

Performance of these systems is compatible with the widely-accepted standards of the Inter-Range Instrumentation Group, making it possible to playback 3900-tapes on other IRIG-compatible systems, and vice-versa. Representative specifications include: 0.2% p-p flutter (dc to 200 Hz, at 30 and 60 ips); extremely low inter-channel crosstalk (even when direct and FM channels are mixed on the same head stalk); 40 db or better signal-to-noise ratio; direct connection of single-ended inputs from 0.5 to 10 V rms (direct) and  $\pm 1.2$  to  $\pm 3$  V p-p (FM), 20 k input resistance; 4 sec. max. start time and 2 sec. max stop time; max. interchannel time displacement error  $\pm 1$  microsec. at 60 ips.

**Advantages in Medical/Biophysical Applications.** Magnetic tape instrumentation offers the clinical and research investigator a unique means of obtaining *all* physiologic data from a procedure—economically, in a compact medium, and in its original dynamic form. Moreover, it enables him to *reproduce* the original data seconds or days later, either at its original frequency or over a longer or shorter time interval, by oscilloscope display, graphic recording, or for further processing by instruments such as electronic integrators, differentiators, spectrum analyzers, or analog-to-digital converters for computers analysis. The Hewlett-Packard system in one hospital heart station, for example, puts all measured data on tape with simultaneous monitoring by scope; tape playback is occasionally used during the procedure for a "second look" at significant events, and at a later time to review all data to select specific portions for permanent graphic recording. The laboratory also uses a second 3907B system, in conjunction with data-analyzing instruments, to tape record derivations of the original data while preserving the original tapes.

An important advantage to the purchaser of magnetic tape recording systems for OR and laboratory facilities such as these is the *compatibility* of 3900 systems with all other Hewlett-Packard/Sanborn equipment in the system. This characteristic, described in the examples on the facing page, is augmented by such other benefits as ease of tape reel loading; system alignment without elaborate equipment or special skills; rapid location of data by precision footage counter; virtually no maintenance of tape transport mechanism; availability of optional tape speeds; purchase of only those circuit plug-ins needed for desired operating mode; and the wide choice of accessories shown at left.

# SYSTEMS CAPABILITIES



# RESEARCH

The photograph at right and the functional block diagram below show two of many systems using 3900-series magnetic tape instrumentation, in conjunction with other Hewlett-Packard signal conditioning/recording/display instruments, which have been designed, built and installed by Sanborn Division. The system at right is designed for a Cardiovascular Research Laboratory of an 800 bed hospital, and is capable of displaying up to eight phenomena simultaneously on a 17" oscilloscope; photographically recording six variables from dc to 500 Hz; recording and reproducing 7 variables from magnetic tape. One of the system's important functional elements is a signal distribution and control unit (Model 568-2000 Control Panel, below signal conditioners in left cabinet): it enables the operator to select either the signal conditioner outputs or tape recorded data for display and/or graphic recording; attenuate, position, remove and calibrate each signal according to the needs of a specific procedure and for uniform correlation among traces—from a single, compact, self-powered unit which is a standard Sanborn product and integral to the system.

The systems engineering capabilities represented by the block diagram are applicable to the monitoring/recording requirements of a catheterization laboratory. Maximum information with minimum equipment and clutter in the cath. lab itself (dotted outline) are provided by features such as waveform and numerical displays at both ends of the room, all patient signal leads fed to other instrumentation (in an adjoining room) through a junction box on the OR table, and a max. signal display capacity of 10 patient variables. This system also employs both 350 and 760-series signal conditioners because of the number and nature of the physiologic variables, and in certain instances, to derive additional data from these variables. As in the system above, the Control Panel affords the operator convenient and complete control and adjustment of signals and desired signal paths.

Although these two configurations are representative of many different systems, each specifically oriented to the needs of a particular OR, hospital laboratory or research center, they provide their users with advantages no other company can offer: a *complete* choice of medical electronic instrumentation for all needed functions; *standard* instruments, cabinetry and cabling designed to be *electrically* and *mechanically* compatible with

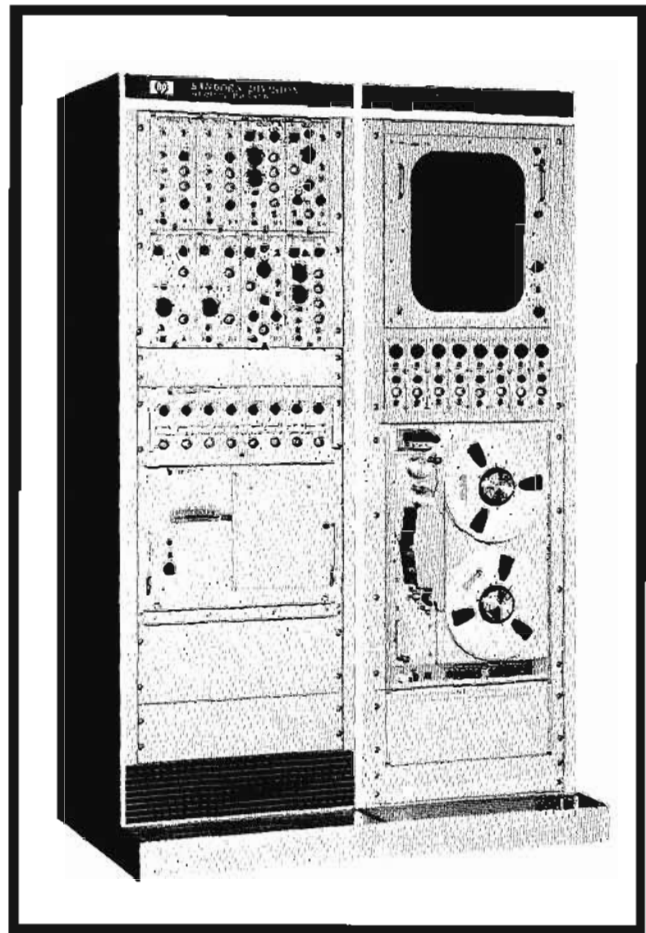

each other; a *single*, highly-experienced source of total system design, manufacture and check-out of all system components, and responsibility for proper operation; and constantly available service from people completely familiar with every element of the system.

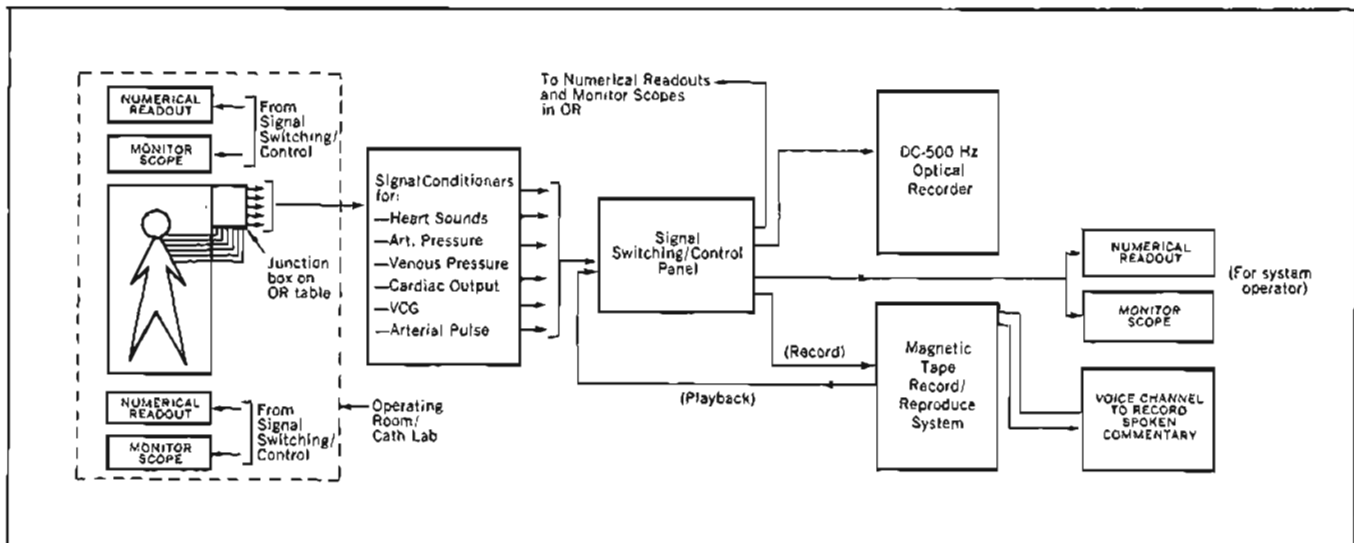

RESEARCH



## VECTOR SYSTEM

Extended capabilities in vectorcardiography  
Model 1520A

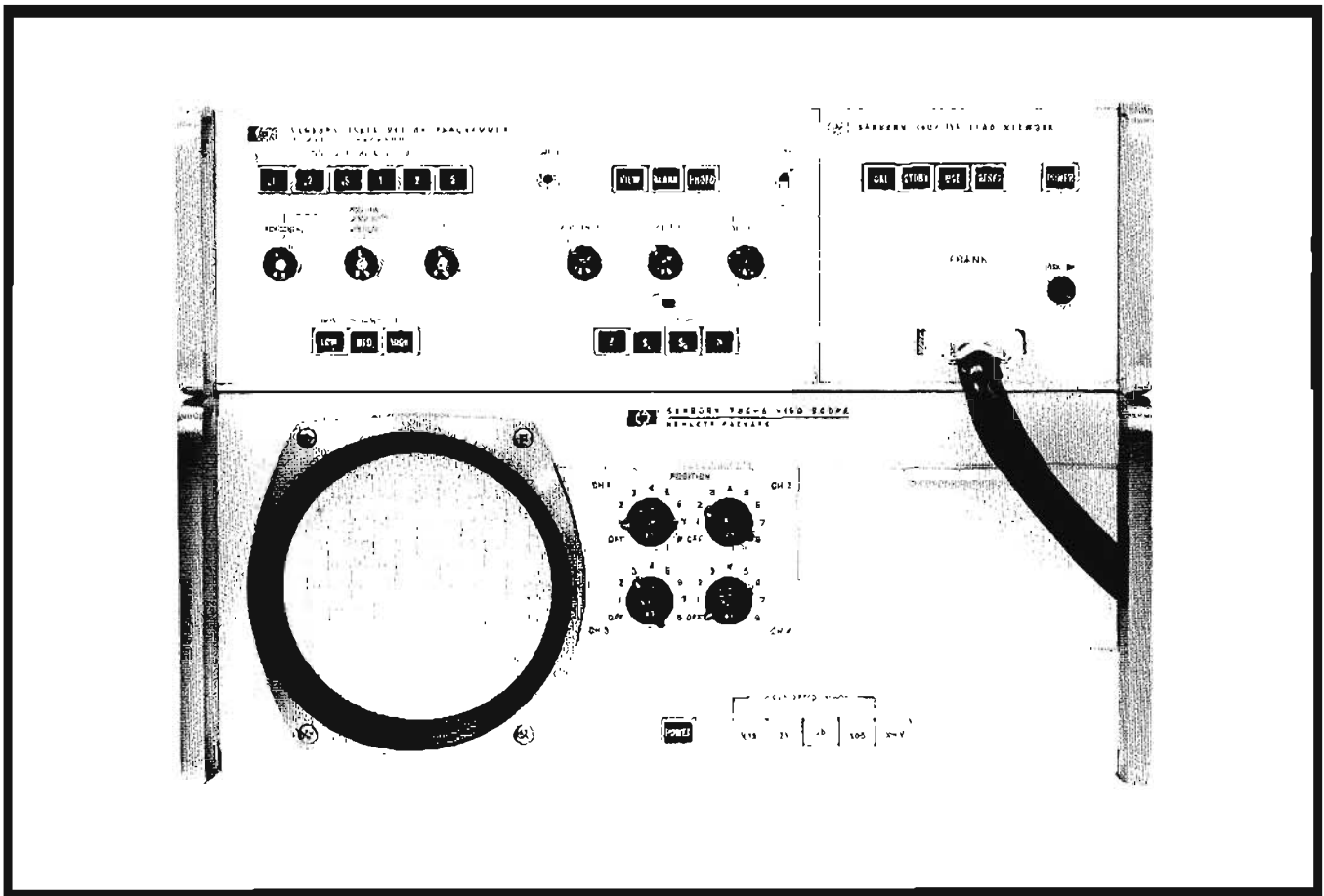

Compact, versatile, easy-to-use — the Sanborn Model 1520A Vector System is designed for both clinical and research vectorcardiography. The system consists of the Model 1507A Vector Programmer and the Model 780-6A Viso-Scope with the Model C04-197A Hewlett-Packard Scope Camera optionally available.

The Vector Programmer provides pushbutton selection of vector loops in the frontal, sagittal, or horizontal planes. Teardrop-shaped dashes are provided in loop display, if desired, to indicate direction of rotation and time in 1, 2.5 or 5 msec intervals. The programmer includes 3 ECG Amplifiers which make possible 3-channel sweep display and recording of the orthogonal components  $V_x$ ,  $V_y$ ,  $V_z$ , in addition to vector loops. The display unit section of the programmer provides controls which permit great versatility in the presentation of vector information. For example, the 1507A System can be programmed to present a single VCG loop automatically at the push of a button. Additionally, P, QRS, or T segments may be selected and enlarged for loop or sweep display. These and other features pictured and described on the next page make it possible to obtain records of excellent photographic quality easily.

The programmer accepts the user's choice of either the Frank (Standard) or Cube/Tetrahedron (Option 01) plug-in vector lead networks. This plug-in flexibility allows for

system compatibility with other present, as well as future vector lead systems. High impedance electrode amplifiers are included for each lead to permit the use of electrode creme and preserve summing accuracy in lead resistive networks. A right leg circuit reduces power line interference and affords patient protection. Appropriate patient cables with coded, fluid column electrodes are provided with the selected lead network plug-in.

The 780-6A Viso-Scope is equipped with an electronic switch for simultaneous display of the orthogonal components  $V_x$ ,  $V_y$ ,  $V_z$ . The scope provides pushbutton selection of the following sweep speeds: 25, 50, 100, 250, 500 and 1000 mm/sec or loop display. The higher sweep speeds enable accurate QRS duration determinations with time resolution to 1 msec/mm. In the sweep display mode, time information is readily obtained throughout the entire cardiac cycle.

The small size and modular configuration of the system permits mounting on a 780-10 Cart for moving to the patient's bedside or other areas of the hospital.

For photographing scope traces, the new Hewlett-Packard C04-197A Scope Camera is available as an optional accessory. The entire camera can be swung away from its mounting when not in use to expose scope face.

# VECTOR SYSTEM

Extended capabilities in vectorcardiography  
Model 1520A



## RESEARCH

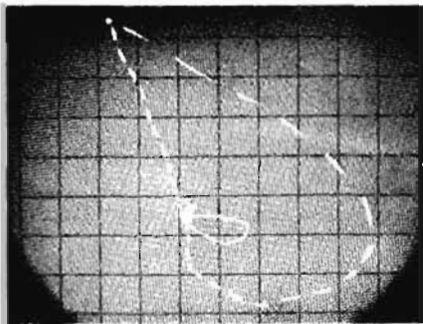

Horizontal plane vector loop with illuminated graticule. The HP Scope Camera attaches to the bezel of the scope. The operator programs the desired vector loop and simply opens the camera shutter to automatically obtain a picture of one complete loop.

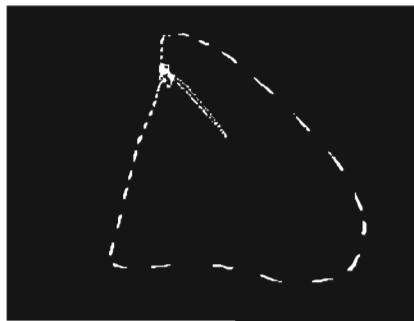

Frontal plane. Consecutive viewing of frontal, horizontal, and sagittal planes is easily accomplished by pushbutton selection. P and T loops are clearly recorded; beam velocity modulation prevents fill-in of "e" point.

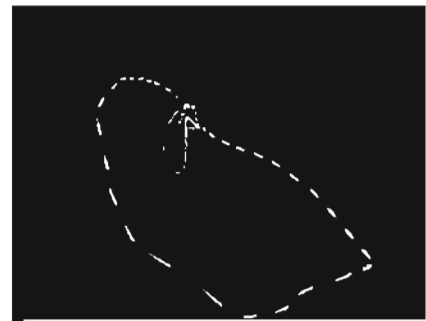

Sagittal left plane. Teardrop shaped dashes may be applied to the loop to give information on direction of loop travel and timing. The heavier end of the dash points to the direction of loop travel.

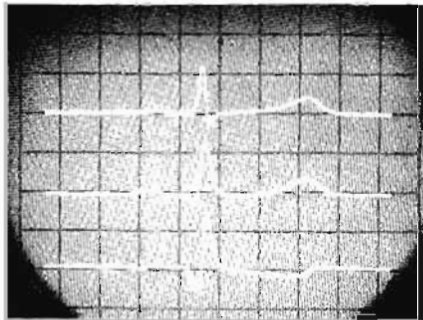

Three separate ECG amplifiers allow simultaneous presentation and recording of the orthogonal  $V_x$ ,  $V_y$ , and  $V_z$  voltages versus time, thus permitting detailed comparison and analysis of these leads.



"P-loop" sagittal left plane. Sections of the VCG loop, such as the P-wave loop, can be selected for display and can be enlarged while the remainder of the loop is simultaneously "blanked out". Sensitivity: 0.05 mV/cm.

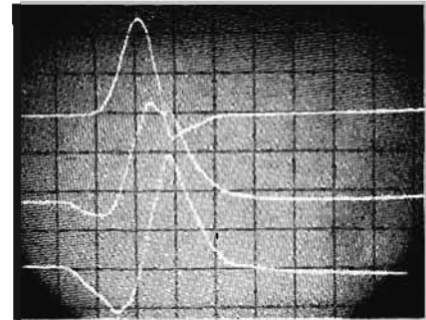

$V_x$ ,  $V_y$ ,  $V_z$  components of the QRS wave are sweep synchronized. Precise timing of QRS complexes or other segments of the cardiac cycle can be achieved using increased sweep speeds of 250, 500 and 1000 mm/sec.

## Specifications

### 1507A Vector programmer (amplification)

**Sensitivity:** sensitivities of 0.1, 0.2, 0.5, 1, 2 and 5 mV in per volt out,  $\pm 2\%$ , for 3 channels of ECG amplification.

**Electrode amplifiers:** buffer amplifier for all electrode leads (except right leg) presents an input impedance  $> 50$  megohms to electrodes and an output impedance of approx. 50 ohms to vector lead network.

**Common-mode rejection:**  $> 500:1$  at line frequency. Special right leg amplifier is incorporated to reduce the amount of common-mode signal on the patient.

**Outputs:** single-ended to ground,  $\pm 3$  volts across 800 ohms minimum.

**Bandwidth:** LOW, MEDIUM, and HIGH selections are provided with approximate 3 dB points of 50, 200 and 1000 Hz respectively. The low frequency time constant is controlled by a single RC circuit with a cutoff point  $> 2.2$  sec. Through an RC pre-emphasis network an effective time constant  $> 3.5$  seconds is presented to the first 200 msec of a changing voltage.

**Positioning:** individual position control to  $\pm 3$  volts is provided for each of the three ECG amplifiers.

**Noise:** noise is less than 10  $\mu$ V pp referred to the input with 50 K ohm source impedance and 1000 Hz bandwidth.

**Calibration:** 0.5 mV  $\pm 2\%$  dc pulse calibrated reference for the three ECG amplifiers; 2.0 V  $\pm 1\%$  dc signal for calibrating the oscilloscope and other associated equipment.

### 1507A Vector programmer (display)

**Direction and timing:** teardrop-shaped dashes are provided at 1, 2.5 and 5 msec ( $\pm 3\%$ ) intervals.

**Logic circuitry:** functions on heart rates from less than 20 BPM to over 300 BPM.

### 780-6A Viso-scope (Option 01)

**Sensitivity:** loop display: 2 cm deflection per 1 volt in. Sweep display: 1 cm deflection per 1 volt in.

**Sweep range:** 25, 50, 100 mm/sec with an X10 switch to provide sweeps of 250, 500, and 1000 mm/second.

**X-Y operation:** loops selectable with front panel pushbutton. Internal graticule: 10 cm x 10 cm, marked in cm squares with 2 mm subdivisions on major axes.

### Physical characteristics of 1520A system (1507A and 780-6A combined):

**Color:** blue cabinets with white enamel front panels.

**Weight:** net 50 lbs (22.5 kg); shipping 70 lbs (31.5 kg).

**Dimensions:** 12 $\frac{3}{8}$ " high, 16 $\frac{1}{4}$ " wide, 18 $\frac{3}{8}$ " deep (320 x 425 x 467 mm).

**Power:** 115 or 230 volts  $\pm 10\%$ , 50 or 60 Hz, approx. 125 watts.

### Prices

**Model 1520A Vector system:** including 1507A Programmer with Frank lead network plug-in and patient cable, 780-6A Viso-scope with Option 01 Electronic Switch, and joining bracket installed between 1507A (above) and 780-6A (below), \$2500.

**Model 1520A:** Option 01 same as 1520A except Cube/Tetrahedron lead networks plug-in and patient cable are substituted for Frank lead network and patient cable, \$2560.

**Model C04-197A:** Hewlett-Packard Scope Camera (same as HP 197A but with shutter synchronization cable which connects between scope and camera and automatically activates display circuitry when camera shutter is opened), \$490.



## ULTRASONIC DIAGNOSIS

Easily-obtained data on internal body structures  
Model 7214A

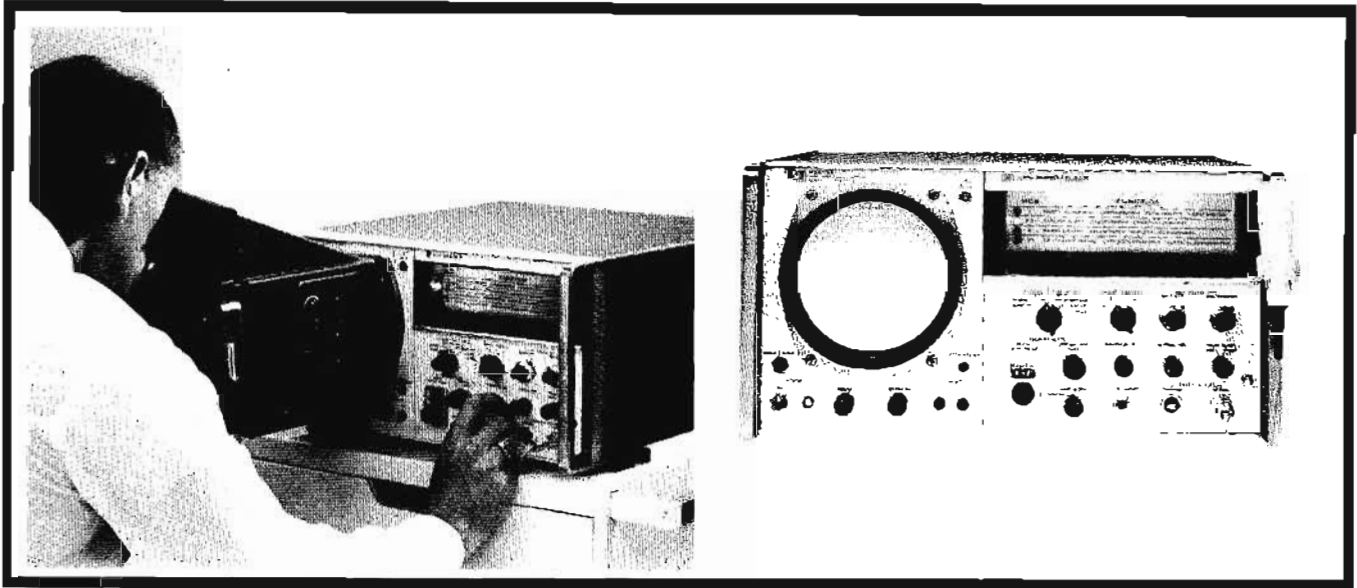

**The Model 7214A Diagnostic Sounder** — with associated transducers is a new, easily-operated ultrasonic diagnostic system with versatile usefulness in both clinical and research applications. Used alone or in conjunction with other diagnostic methods, the 7214A permits rapid, safe and accurate determinations in areas such as:

**Sono-Encephalography (SEC) in neurology** — for determining brain mid-line displacement caused by space-occupying lesions; measuring ventricular structures; detecting certain hematomas and tumors.<sup>1-2</sup>

**Echo-Cardiography in cardiology** — for observing the motions of the mitral valve and heart walls, in the diagnosis of mitral stenosis and pericardial effusion.<sup>3-4</sup>

**Fetalometry in obstetrics and gynecology** — for measuring the biparietal diameter of a fetal head as an aid to determining fetal weight and growth pattern.<sup>5</sup>

**Ocular pathology in ophthalmology** — for measuring eye length, cornea and lens thickness; studying myopia, growth, circulation, detached retinas, glaucoma and similar conditions; and for locating foreign particles in the eye.<sup>6</sup>

**Renal studies in internal medicine** — for estimating the amount of urine in the bladder by measuring the A-P diameter of the bladder; determining insertion depth of biopsy needle; and locating renal stones during surgery.<sup>7</sup>

**Principle of operation**—the 7214A uses the difference in ultrasonic reflective properties between a tissue interface or internal structure and those of surrounding tissue of a different density or elasticity. The system generates a series of very short ultrasonic pulses (in the 1 MHz to 10 MHz frequency range) which are transmitted into the body by a transducer in firm contact with the surface of the body, and through a coupling medium such as an ultra-sound transmission gel. When the pulses encounter a tissue interface or internal structure whose density or elasticity is different from the surrounding tissue, an echo pulse is reflected to the transducer and displayed on the monitor. With the screen calibrated in centimeters, the depth of the pulse-reflecting tissue interface or structure can be read directly. Data is obtained quickly and easily, without danger or discomfort to the patient.

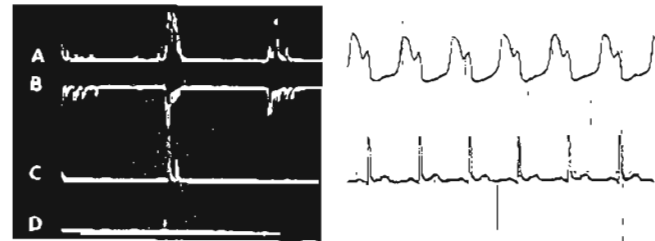

A-Scan mode showing brain mid-line examination of normal patient. (A) Right to left examination using normal vertical deflection. (B) Left to right examination using inverted vertical deflection. (C) Through transmission, notice through distance corresponds to distance of mid-line echo. (D) Marker trace set to indicate mid-line echo.

T-M mode showing a recording of the motion of the mitral valve (top), taken simultaneously with an ECG (bottom). Upstroke of the curve represents movement towards the chest wall. Downstroke represents movement away from chest wall.

Separate operating modes are provided for (1) *measuring fixed distances* between interfaces ("A-Scan") and (2) *locating and visualizing physiologic structures in motion* ("T-M" or "Time-Motion"). An example of each measurement is shown in the study of the mid-line structure of the brain (A-Scan) and in the motion of the mitral valve (T-M) in the photographs above.

**Features and advantages** — to provide optimum performance of the system and greatest measurement accuracy, four different transducers are available: 1 MHz, 2.5 MHz, 5 MHz and 10 MHz. The 2.5 and 5 MHz types are recommended for most applications; 1 and 10 MHz types are designed for better penetration and more resolution respectively. Connecting the transducers to the front panel jack automatically selects corresponding operating frequency and lights an indicator identifying the frequency.

Bright, clear, parallax-free traces in a large 10 cm x 10 cm display area are achieved by a special internal graticule, which also facilitates high-quality photographs made with the new HP 197A Scope Camera. Depth measurements accurate to within one mm are made possible by a calibrated marker trace used with a front panel numerical readout. If the user wishes

## ULTRASONIC DIAGNOSIS

### Easily-obtained data on internal body structures

Model 7214A



# RESEARCH

to compare two moving interfaces or structures simultaneously, an optional variable-persistence scope permits retention of one signal on the scope face for up to one hour. Other features which simplify the operation of the 7214A Diagnostic Sounder include calibrated gain controls for quickly resetting instrument to previously-determined values; beam-finder pushbutton which brings trace on the screen regardless of intensity or position control settings; and an audible tone signal whose pitch varies according to echo amplitude in A-Scan mode, and echo motion from the start of the gate in T-M mode, to help prevent loss of signal.

For scope trace photography, the new HP 197A Scope Camera (see page 460) produces high-quality prints of excellent resolution and contrast, quickly and easily. Built-in ultraviolet light illuminates the internal graticule. Standard Polaroid® camera back is interchangeable with 4" x 5" Gra-flok® back.

For permanent records of T-M measurements, a signal for strip chart recording is available at a front panel jack, this permits simultaneous recordings with electrocardiograms and/or phonocardiograms.

#### Reference bibliography — ultrasonic diagnostic applications

1. Grossman, Charles C.: *The Use of Diagnostic Ultrasound in Brain Disorders*, C. C. Thomas, Publisher, Springfield, Ill., 1966.
2. McKinney, W. M.; Thurstone, F. L.; Avant, W. S. Jr.; and Wallace, W. K.: "The Significance of Intracranial Echo Pulsations", *Diagnostic Ultrasound\**, pp. 114-116, Plenum Press, New York, 1966.
3. Edler, Inge: "Mitral Valve Function Studies by the Echo Method", *Ibid.*, pp. 198-228.
4. Joyner, C. R. Jr.: "Experience with Ultrasound in the Study of Heart Disease and the Production of Intracardiac Sound", *Ibid.*, pp. 237-248.
5. Thompson, H. E.: "Studies of Fetal Growth by Ultrasound", *Ibid.*, pp. 416-426.
6. Sokollu, A.: "The Use of Diagnostic Ultrasound in Eye Research", *Ibid.*, pp. 46-58.
7. Holmes, J. H.: "Ultrasonic Studies of the Bladder and Kidney", *Ibid.*, pp. 465-480.

#### Specifications, 7214A Diagnostic Sounder

**Operating modes:** A-Scan or T-M study; in A-Scan the vertical deflection is either normal or inverted for range info.

**Test frequencies:** 1, 2.5, 5 or 10 MHz, selected by connecting desired transducer (see page 72 "Features and Advantages" for transducer applications).

**Display:** cathode ray tube with an internal graticule calibrated in centimeters.

**Depth range:** 0.5 to 50 cm of tissue.

**Depth resolution:** 1 mm or less at 10 MHz.

**Marker:** range marker on alternate trace, for accurate measurement of distance from start of transmitted pulse.

**Trace height:** max. 2 or 5 cm, selectable by operator.

**Vertical sweep:** variable speed, for T-M mode.

**Gate:** permits selection of any echo or group of echos.

**Audio output:** tone frequency depends on amplitude of echo

appearing in gate during A-Scan, and on motion of echo from start of gate in T-M.

**Pulse rep. rate:** approx. 500 Hz.

**Avg. power from acoustic element:** less than 2 mW.

**Time varying gain:** approx. 80 dB of time varying gain provided by calibrated front panel controls to compensate for attenuation due to tissue absorption and scattering.

**Input connections:** two, on front panel, for transducer: normal for pulse echo operation, or through transmission mode used for calibration purposes.

**Output connection:** T-M recorder output signal jack on front panel; capable of supplying a minimum  $\pm 1$  volt open circuit.

**Circuitry:** all silicon solid-state, except for CRT and its power supply.

**Size:** 9" high, 16 $\frac{3}{4}$ " wide, 18 $\frac{3}{4}$ " deep (229 x 426 x 476 mm).

**Weight:** net 50 lbs (22,7 kg); shipping 60 lbs (27,2 kg).

**Power:** 115/230 V, 50-60 Hz, 285 watts.

**Prices:** consult Hewlett-Packard field sales office for prices of 7214A, variable persistence monitor option and accessories.

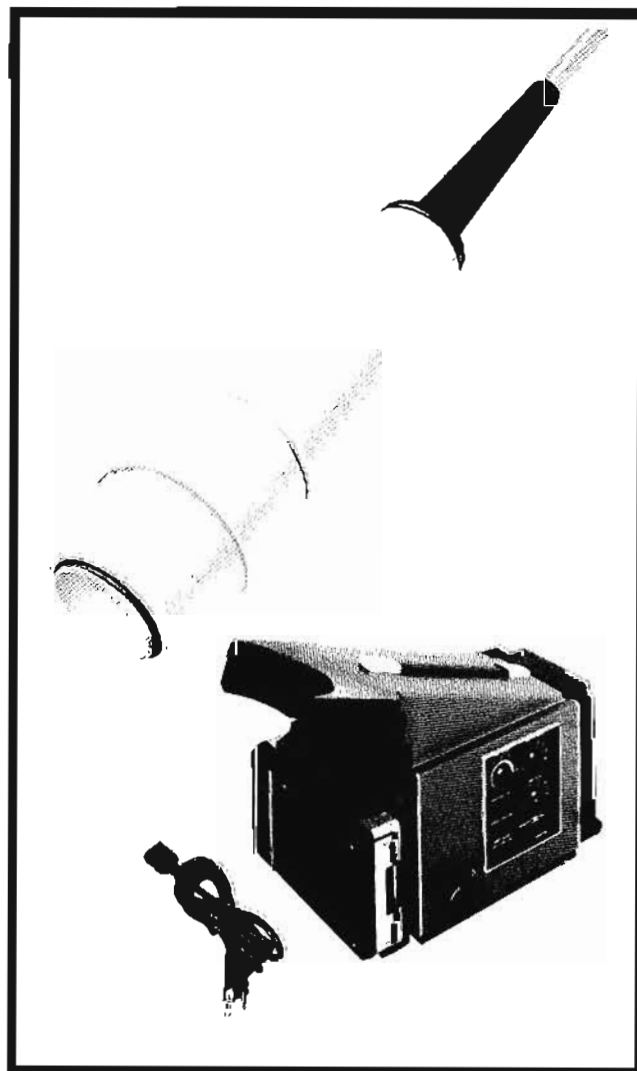

\*Contains the Proceedings of the First International Conference of the Society for Diagnostic Ultrasound, University of Pittsburgh, May 1965.





## HEART SOUND AMPLIFIER

Diagnostic heart sounds with ECG recorder  
Model 1506A

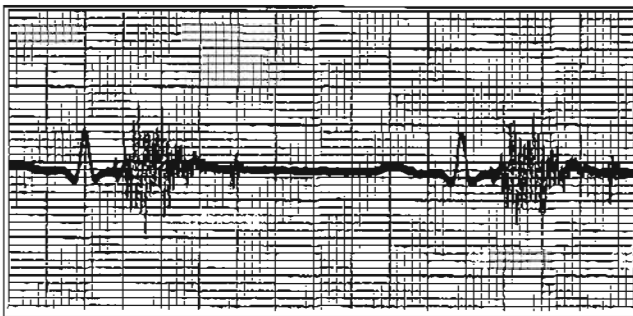
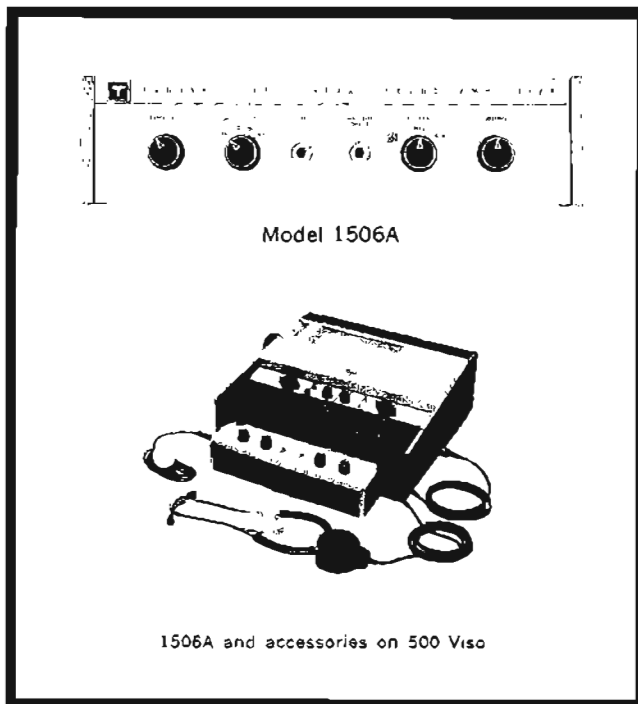

PCG mixed with ECG to establish timing of first sound

Model 1506A Heart Sound Amplifier permits heart sound recordings of diagnostic quality to be made by a 500 Viso, 100 Viso or other ECG's having a 50 mm/sec. chart speed and adequate frequency response. Such recordings can provide valuable information on the location, intensity and duration of sounds and murmurs, and the 1506A can also serve as an electronic stethoscope for listening at normal or amplified levels. Three recording modes are available: ECG only, PCG (phonocardiogram) only, and Lead II ECG superimposed on PCG, for timing. Used with a 500 Viso, the system covers a heart sound frequency range from 50 to 2000 Hz (cps) with recording resolution of 0.01 sec. The 1506A operating principle involves electronic detection of the heart sound waveform envelope, with sampling at an 85 Hz rate, with the resultant signal fed to the input of the cardiograph for graphic recording.

The 1506A is a compact, lightweight unit with all solid-state circuitry, self-powered by long-life internal batteries (6 mos. with an average use of 2 hrs./day). It clips easily and securely to the front of a 500 Viso. Controls are provided for recording mode (ECG, PCG, ECG-PCG Mix); cut-off freq. (50, 100, 250, 500 cps); sensitivity; audio-phone volume; battery check; and calibration.

### Specifications

**Input Impedance:** approximately 5 megohms.

**Microphone:** an input jack is provided for use with crystal or other high impedance microphones.

**Calibration:** with the microphone disconnected and the Cal. button pushed, an 85 Hz signal ( $\pm 6$  cycles) of approximately 4.5 millivolts peak is applied to the input stage. Cal. signal should be used only with the Cut-off Freq. switch on the 50 Hz filter position.

**Sensitivity (at 1000 Hz):** not more than 10  $\mu$ V rms input is required to produce 1 mV peak-to-peak signal going to the cardiograph input with Cut-off Freq. switch at 500 Hz, Sensitivity control at maximum and Record switch on PCG or Mix.

The sensitivity of the unit at 1000 Hz in the other filter positions is as follows:

Filter Switch	Input Signal to Produce 1 mV Peak-to-Peak
50 Hz	+40 dB $\pm$ 3 dB*
100 Hz	+28 dB $\pm$ 3 dB*
250 Hz	+12 dB $\pm$ 3 dB*

\* (referred to 18  $\mu$ V rms input to amp).

**Frequency response:** the high frequency cut-off is fixed for all filter positions down 3 dB at 2000 c/s with a slope of approximately 12 dB/octave. The low frequency cut-off is down 3 dB at 50, 100, 250, or 500 Hz depending on the position of the Cut-off Freq. switch. The filters roll off at 24 dB/octave. The response in the pass band is flat within  $\pm 3$  dB.

**Envelope detection and modulation:** both the positive and negative envelopes are detected and stored in capacitors with an approximate discharge time constant of 14 milliseconds. The envelopes are chopped at an 85 Hz rate ( $\pm 6$  cycles) and summed together. The 50 Hz position of the Cut-off Freq. switch is the only position that by-passes the modulator.

**Output:** a maximum undistorted signal of 6 mV peak-to-peak is applied to the input of the cardiograph with the Record switch in PCG and the Cut-off Freq. switch in any position except 50 c/s. In the 50 c/s position the maximum undistorted signal is 4 mV peak-to-peak. The output impedance is approximately 27 k.

**Size:** 2 $\frac{1}{4}$ " high, 10 $\frac{5}{8}$ " wide, 2-13/16" deep (58 x 270 x 72 mm).

**Weight:** 1 $\frac{3}{4}$  lbs (0.79 kg).

**Power:** 13.5 V at 2 mA, supplied by two 6.75 V internal batteries in series. (Easily checked by recording output voltage pulse on 500, using battery check pushbutton.)

**Prices:** Model 1506A with Contact Microphone (14011A), Audiophone (62-1500-C9), and Output Cable to 500 Viso (14017B), \$450. Option 01, for use with Model 100 Viso ECG (14021A Output Cable to 100 Viso, 5-pin to 6-pin adapter to connect 100 Viso patient cable to 1506A), no extra charge.

## PATIENT MONITORING

Readout: thermal dilution; cardiac computer  
Models 5601A; 350-15; 130



# RESEARCH

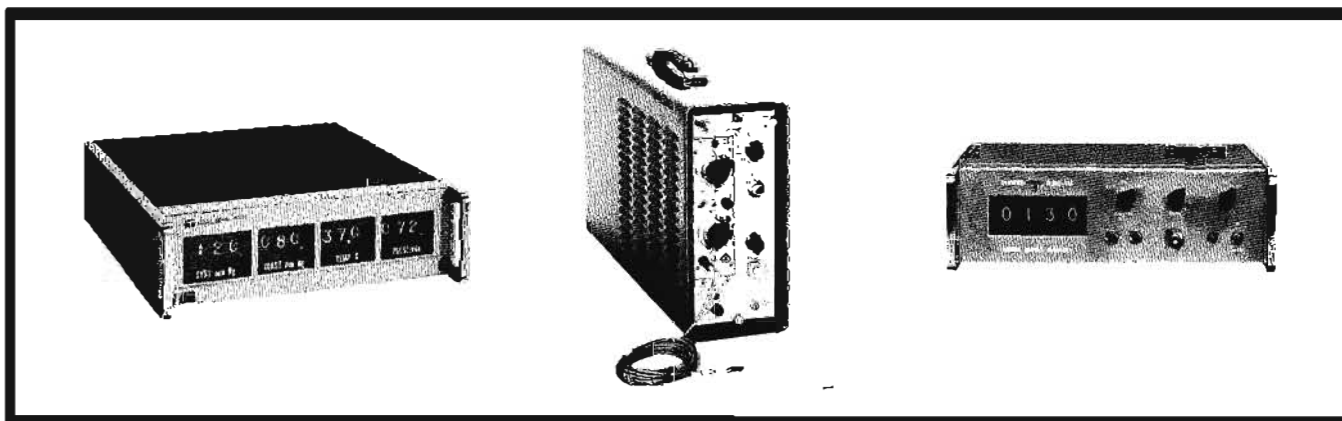

Models 5601A; 350-15; 130

Model 5601A Numerical Readout displays 3-digit values of four slowly-changing phenomena such as blood pressures; heart, pulse and respiration rates; and temperature. Each channel samples phenomena at a rate adjustable from once every 1.5 sec. to once every 10 sec. Input can be from 780-series monitors; 350, 760 or most other medical signal conditioners. Highly visible lighted numerals 0.6" high display values: left-hand channel can have a fourth digit, the numeral "1" only, as the most significant figure for temperature in °F (see Option 10). Illuminated decimal point in each channel can be manually positioned, and will blink to show rate of phenomena when connected to rate signal from 760-3, or suitable 780-series monitor. Instrument can be ordered with user's choice of sequence and type of phenomena according to options listed, and easily modified for other types or sequences by Hewlett-Packard field office. For multiple display, several units may be synchronized by interconnection. Outputs available for HP Model 562A Digital Recorder. Size: 16 $\frac{3}{4}$ " wide, 5-9/16" high, 16 $\frac{3}{8}$ " deep (426 x 141 x 422 mm). Weight: 30 lbs (13,5 kg). Power: 115/230 V, 50-60 Hz, 40 watts. Prices: 5601A sub-system (w/out readout modules), blue case, white panel, \$700. Option 01, gray panel, no added charge. Following options are readout modules, any four of which added to sub-system make a complete unit: 02, Systolic, 0-300 mm Hg: \$350; 04, Venous, 0-30 mm Hg: \$350; 05, Pulse, 0-300/min: \$350; 06, Heart Rate, 0-300/min: \$350; 07, Mean, 0-300 mm Hg: \$350; 08, Temp, 10-40°C: \$450; 09, Temp, 30.0-45.0°C: \$450; 10 Temp, 90.0-105.0°F (Ch. 1 only): \$450; 11, Resp, 0-75/min: \$350.

Thermal Dilution System consists of a 14012A calibrated thermistor temperature probe, 350-15 calibrated bridge circuit plug-in used in a 350-1500A Low Level Pre-amplifier, and for readout a Sanborn multi-channel recorder or Moseley single-channel 5" strip chart recorder. Cardiac output determinations may also be obtained by connection to a Model 130 Cardiac Output Computer (see below). The system permits estimation of left ventricular volume, by rapid and accurate measurement of the thermal dilution occurring at a point downstream from the injection site of

sterile saline in a chamber of the heart. The technique and system allow estimation of left ventricular volume from beat-to-beat data; measurement without withdrawing or re-infusing blood; greater economy than dye dilution methods; excellent patient tolerance of indicator without baseline build-up or recirculation; and fast response to intracardiac dynamic changes. Thermistor probe is aged and selected for stability, individually calibrated and supplied with chart showing absolute temperatures to two decimal places corresponding to one-ohm increments between 1000 and 2999 ohms. Probe is 125 cm long, 1 mm O.D. (0.39") or French scale 3. Prices: Model 14012A Thermistor Probe, 10' cable, calibration chart: \$190. Model 350-15 Thermal Dilution Plug-In (for 350-1500A): \$265. Model 350-1500A Low Level Pre-amplifier and 350-500B Power Supply in 450 portable case: (115/230 V, 50-400 Hz): \$790. Less case, deduct \$90. Less Power Supply, deduct \$175.

Model 130 Cardiac Output Computer, used with most standard densitometers such as Gilford and Waters, or other indicator dilution device, automatically computes the area of the primary circulation curve, provides the calibration factor and continuously displays data in illuminated numerical form. By eliminating the need to re-plot the dye curve and manually compute the area under the curve, it enables the user to make decisions regarding further measurements while the procedure is in progress. Cardiac output in liters/min. is easily obtained by simply dividing totalized integration count by the calibration factor. Continuous "on-line" operation provides all needed data in usable form slightly before completion of dye curve. Additional features of the 130 include: a baseline sensing circuit to assure maximum integration accuracy of the primary circulation curve, and which also eliminates the necessity of zeroing the densitometer at the beginning of each dye curve; sufficient readability of numerals from a distance to permit remote operation of Start and Reset controls; electrical binary coded decimal output suitable for printers, digital computers; and recorder output for graphic recording of the dye curve. Size: 5 $\frac{1}{4}$ " high, 19" wide, 11" deep (133 x 483 x 280 mm). Weight: 21 lbs (9,4 kg). Power: 115/230 V, 50-60 Hz, 70 watts. Price: Model 130 Cardiac Output Computer, \$1550.



# Data Acquisition Systems and Recorders

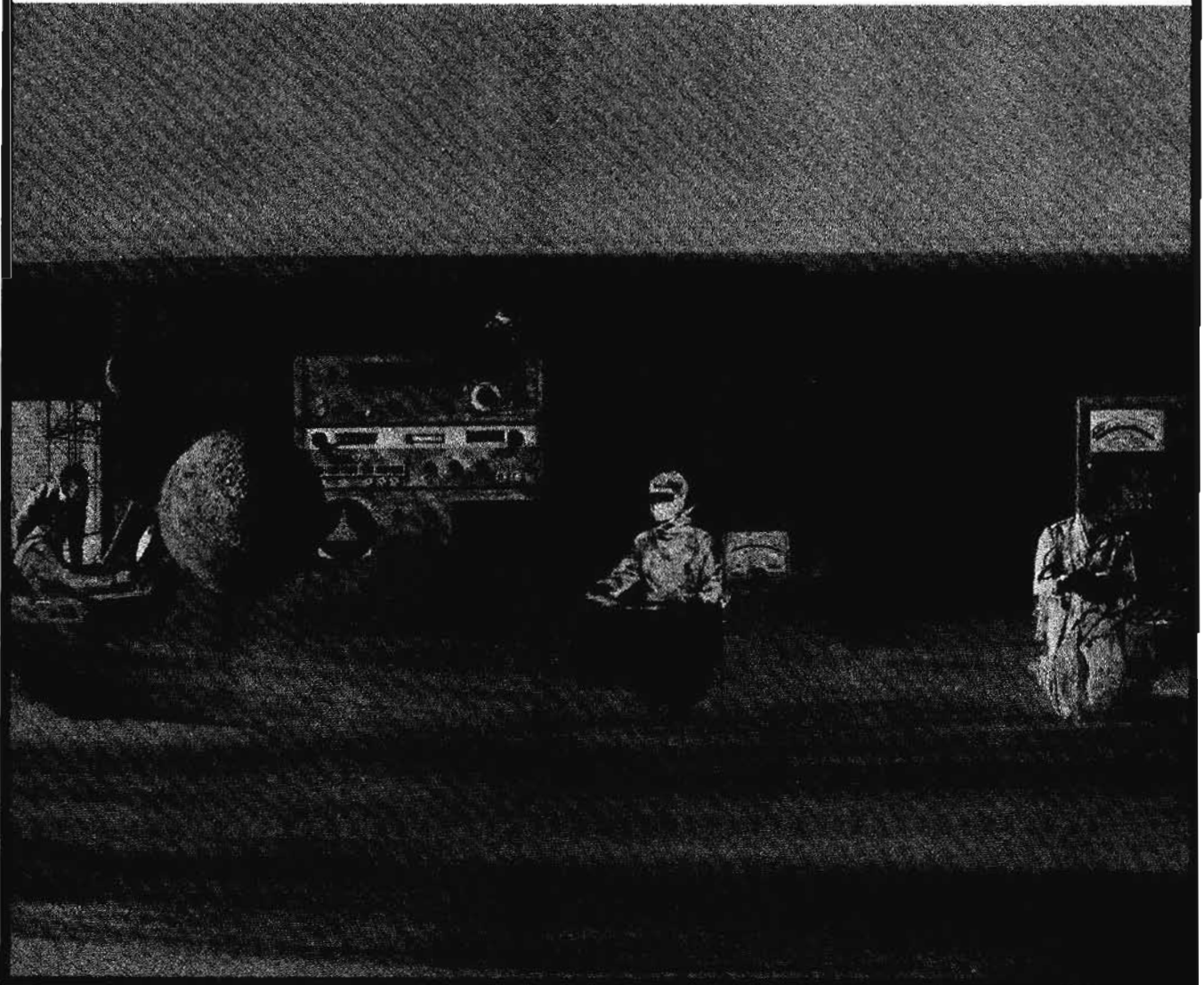

# Data Acquisition Systems and Recorders

<b>Digital System Elements . . . . .</b>	<b>80</b>	<b>Digital Recorders . . . . .</b>	<b>93</b>
Input Scanners		Digital Data Plotting System	
Programmrs		Digital Recorders, Printers and Clocks	
Signal Conditioners		Digital-to-Analog Converter	
Analog-to-Digital Converters			
Output Couplers		<b>X-Y Recorders . . . . .</b>	<b>99</b>
Auxiliary Equipment		<b>Strip Chart Recorders . . . . .</b>	<b>109</b>
<b>Data Acquisition Systems . . . . .</b>	<b>84</b>	<b>Oscillographic Recorders . . . . .</b>	<b>120</b>
Digital Data Acquisition Systems		<b>Magnetic Tape Recorders . . . . .</b>	<b>146</b>
Instrumentation Computer			



Instrumentation systems can be categorized into two basic classes: digital and analog. An analog system usually consists of a set of signal conditioning and measuring and recording equipment for each transducer. In a digital instrumentation system, the measuring and recording equipment are sequentially used by the transducers; and for a given type of measurement, signal conditioning equipment may be shared. Depending on measurement specifications, scanning equipment also may be shared.

Analog data systems are used when wide bandwidth is required or when less accuracy can be tolerated. Digital data acquisition systems are used when the physical process being monitored is slowly varying (narrow bandwidth) and high accuracy and low per-channel cost are required.

Digital systems range in complexity from economical single-channel dc voltage measuring and recording systems to sophisticated, totally automatic multiple-channel systems that measure all electrical parameters, compare against preset limits and even perform computation and decisions on the input signal. Systems are available with a wide range of speed and accuracy. Applications span individual data logging to high-speed automatic checkout.

Since measurement requirements can change rapidly, data acquisition systems must have the flexibility needed for frequent change to cope with new problems. Data systems produced by Hewlett-Packard's Dymec Division employ standard system-oriented instruments, permitting system modification or expansion to be made simply by changing instruments or adding appropriate new instruments.

#### Where and why data systems are used

Data acquisition systems, in general, are applied in many of the same situations as digital voltmeters. Systems are generally used to measure analog signals originating in two different ways:

1) Direct measurement of electrical quantities. This includes dc and ac voltages, frequency and resistance, and applies typically to areas of electronic component and subassembly testing, environmental and QA testing.

2) Signal inputs from transducers which are in common use, i.e., strain gage and thermocouples. Digital systems are generally found wherever multiple installations of transducers or electrical

pickups are employed and are frequently referred to as data logging systems, whether measured data is prepared for computer entry or logged for manual study.

Dymec data acquisition systems include five basic series of standard packages engineered for a variety of input and output situations. Specific advantages resulting from standard system design include:

**Quick delivery.** Since systems are composed of standard instruments and cables, standard production techniques can be employed.

**Better specifications.** In that each system is a thoroughly engineered and completely tested package. HP can guarantee top system specifications. Systems are completely specified on a data sheet. Moreover, ease of system expansion is assured with a wide variety of options.

**Greater reliability**—through the use of production techniques as applied to standard Hewlett-Packard instruments. These techniques have obvious advantages over the "one shot" system that has to be custom engineered and produced.

**Low price.** Systems are composed exclusively of standard, systems-oriented instruments. Special system engineering prices are not required.

#### Data acquisition systems

The 2010 Series of systems (pages 84-85) measure dc voltage and frequency with both visual readout and permanent output recorded on printed strip, punched card or tape or magnetic tape. Optional equipment permits measurement of ac voltage, resistance, plus dc measurements of  $\pm 10$  mV full scale. Programmable high-low limit comparison can be accomplished on any of the above parameters. System operation can be controlled by either pin-board or punched-tape programming. In this series the measuring element (analog-to-digital converter) is the floated and guarded 2401C Integrating Digital Voltmeter, which permits accurate low-level measurement even in the presence of severe common mode noise and noise superimposed on the measured signal.

The 2013 Series (page 86), which incorporate the 3440A Digital Voltmeter as the measuring device, provide multiple-point scanning capability with output on printed strip, typewritten record or punched card or tape—at an economical price.

The 2015 Series (page 87) incorporates the 3460B Digital Voltmeter (page 228),

as the analog to digital converter. The systems employ the input scanners and output devices common to the 2010 Series, and feature high dc voltage measurement accuracy.

The 2017 Series systems (page 92) parallel the 2010 Series in regard to input and output devices and system auxiliary equipment. All systems incorporate the 2417A Data Linearizer (page 82) to permit direct readout in familiar measurement units. These systems apply to areas of transducer measurement where, for example, display of thermocouple outputs in degrees rather than millivolts is needed.

By incorporating a 2116A small digital computer (pages 88-91) as a data system element, operation of the scanning, measuring and recording devices will respond to the input signal in a pre-determined manner. System components and functional operation are basically the same as a 2010 System. This type of data acquisition system offers flexibility in system programming, timing and sequencing, and computational chores can be done at the time of measurement—operational versatility is expanded manyfold. The system maintains all benefits of the modular system concept common to all Hewlett-Packard digital systems.

#### Digital data system elements

Elements making up a digital system may include all or part of those listed and illustrated. Essential functional operations within a digital system include handling analog signals, making the measurement, handling digital data and internal programming and control. The function of each of the system modules illustrated is:

##### Transducer

Translates physical parameters to electrical signals acceptable by the data acquisition system. Typical parameters include temperature, pressure, acceleration, weight, displacement and velocity. Electrical quantities such as voltage, frequency or resistance also may be measured directly.

##### Signal conditioner

Provides excitation power to transducer. As necessary, it also provides balancing, calibration and bridge completion circuitry. An example is a strain gage bridge balance and power supply unit.

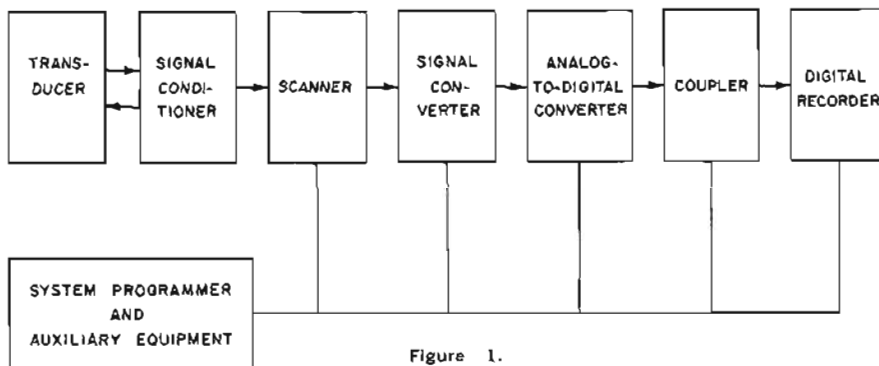

Figure 1.

### Scanner

Accepts multiple analog inputs and sequentially connects the signals to one measuring instrument. Inputs may be in the form of millivolt or high level ac or dc voltage, resistance frequency, period, time interval or events occurring in a specified time interval.

### Signal converter

Translates the analog signal to a form acceptable by the analog-to-digital converter. An example is amplification of low-level signals from thermocouples or strain gage bridges.

### Analog-to-digital converter

Converts the analog signal to its equivalent digital form. Output is a visual display and voltage outputs for further processing or recording on a digital recorder.

### Auxiliary equipment, programmer

Performs system programming and digital data processing functions within a system. Typical functions include hi-lo limit comparison, linearizing, manual data entry, time.

### Coupler

Receives digital information from the analog-to-digital converter and translates it to the proper form for entry into a digital recorder.

### Digital recorder

Records digital information on punched cards, perforated paper tape,

magnetic tape continuous printed paper strips or typewritten pages.

Data acquisition systems are used in many cases to measure low-level signals, and often these measurements must be made in the presence of large amounts of noise. A typical case would be the measurement of a millivolt level dc voltage from a thermocouple, which is measured in the presence of tens or even hundreds of volts of common mode. Other noise sources include electrostatic or electromagnetic pickup, and noise inherent to the transducer. All forms of noise are seen by the digital voltmeter as a periodic and/or random disturbance superimposed on the real signal level.

There are two ways of combatting noise: the voltmeter should be designed to discriminate the real signal from the superimposed noise appearing at its input terminals. Second, effort should be made to prevent these sources of noise from producing superimposed noise at the voltmeter input terminals.

Noise inherent in the transducer will inevitably appear at the voltmeter input as superimposed noise. Electrostatic and electromagnetic pickup on the signal leads, both from the surrounding equipment and the voltmeter power supply circuits, will give rise to superimposed noise unless precautions such as shielding, avoidance of ground loops, etc., are taken. Common mode pickup, which is noise induced in the signal circuit by circulating ac ground currents, requires guarding techniques for its elimination.

## Guarding

Induced ac ground currents, usually at the power line frequency, can generate a potential of several volts between the signal source ground and the voltmeter chassis ground. Unless blocked, these currents will cause a voltage to appear at the voltmeter input which can easily be larger than the signal itself, resulting in a completely erroneous reading. This effect is known as common mode ac pickup. A conventional floating input can reduce common mode pickup to some extent, but it is limited in its effectiveness by the capacitance between the measuring circuit and chassis (Fig. 2a). In addition, current injection from the voltmeter power supply can create a measurement error. Use of a heavy ground buss or shield usually will not reduce common mode pickup appreciably and may even increase it, due to magnetic pickup from the ground loop formed.

Guarding as employed in the 2401C, 3460B, and 3459A completely isolates the floating measuring circuit from the chassis: the guard effectively breaks the common mode loop (see Fig. 2b). With the guard of the 2401C operated at the ground potential of the signal source, the common mode rejection (defined as the ratio between the common mode signal and the spurious voltage it causes to be superimposed on the signal to be measured) exceeds 120 dB at 60 Hz and 160 dB at dc, with a groundleg impedance of 1000 ohms between the source ground and the low side of the voltmeter input.

The 2401C average-reading characteristic further attenuates the common mode voltage. To take a practical example, the combined effect of guarding and averaging is such that a common mode potential of 100 volts will not cause a discernible error in the 2401C reading, even on its most sensitive range.

Guarding provides an absolute solution to the problem of common mode pickup from grounded signal sources. This is especially valuable in systems applications where the alternative solution, floating the signal sources, would be extremely troublesome.

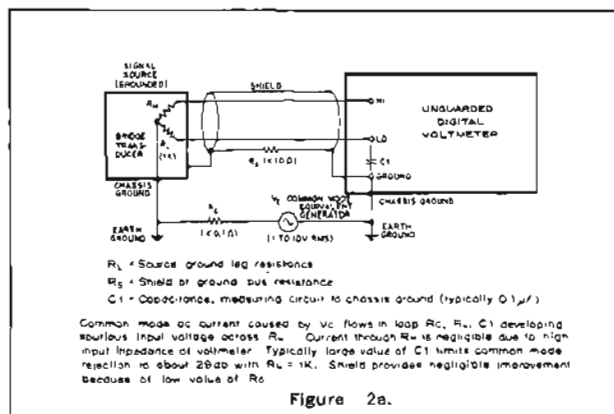

Figure 2a.

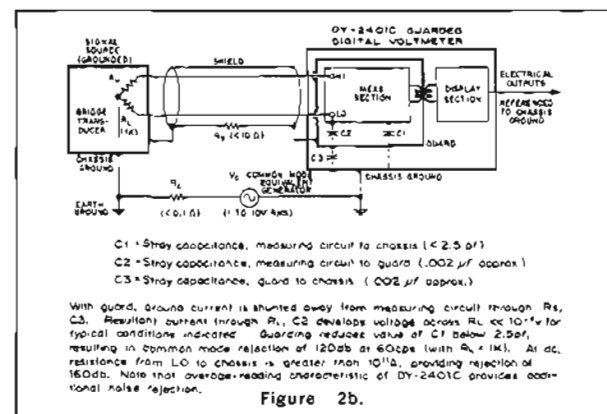

Figure 2b.



### Signal conditioners

2480 Series Signal Conditioning Modules (page 563) provide dc excitation and signal conditioning for strain gage transducers, resistance thermometers and other variable resistance devices. They incorporate full floating and guarding, and are particularly useful in data acquisition systems having guarded digital voltmeters and data amplifiers, pro-

viding maximum system accuracy and minimizing common mode noise problems.

Excitation sources and the associated signal conditioning circuitry share the same instrument case. Ten instruments plug into a combining case which occupies 5¼" (133 mm) of vertical panel space.

Constant voltage, constant current, and "Linear" modes of operation are provided by a standard power supply card. Conversion from one mode to the other is by a switch. Regulation and stability of the power supply is exceptional.

The 2480A excitation source is highly regulated. In the constant voltage mode, changes in output voltage for load current change of 200 mA is  $<600 \mu\text{V}$  at full scale 30 V dc out,  $300 \mu\text{V}$  at .1 V output. A line voltage change of  $\pm 10\%$  from nominal causes  $<600 \mu\text{V}$  at 30 V output,  $300 \mu\text{V}$  at .1 V output. Output voltage variation with temperature change is  $<170 \mu\text{V} + 0.005\%$  of output per  $^{\circ}\text{C}$  change in ambient. Instrument operates accurately in ambients to  $+55^{\circ}\text{C}$ , and at humidities to 95% at  $40^{\circ}\text{C}$ . A companion 2482N Monitor Function Selector determines the parameter to be measured, excitation volts or current or signal. A 2480K Excitation Coupler replaces the power supply in each module and permits multiple signal conditioners to receive power from a common external supply.

The 2481A Resistance Bridge module provides bridge completion and calibration circuitry for 1, 2 and 4 active arm bridges.

**Prices:** are as follows: 2480A Power Supply, \$245; 2480K Excitation Coupler, \$35; 2481A Resistance Bridge, \$65; 2482N Monitor Function Selector, \$125.

### Input scanners

2911 Guarded Crossbar Scanner for rejection of common mode noise. User may select 600 1-wire, 300 2-wire, 200 3-wire, or 100 6-wire inputs. Lower and upper scan limits selectable at front panel, with random access to any channel. Channel being monitored is indicated by in-line visual display and 4-2'-2-1 BCD (optionally 8-4-2-1) output. Roller-mounted switch withdraws from rear for easy cabling. Maximum scanning rate is 30 channels/second. Panel height 14" (355 mm). Price 2911, \$4,650.

2901A Input Scanner/Programmer scans 25 3-wire inputs and programs all functions of associated system. May be expanded to 100 channels with 2902 Slave Units. Easy system set-up with individual quick-release input connectors and pushbutton selection of channels to be scanned. System functions and measurement delay are programmed individually for each channel with built-in pinboard. Maximum scanning rate is 12 channels/second. Panel height 7" (177 mm). Prices: 2901A Master, \$2,375; 2902 Slaves (25 channels each), \$1,975.

2900B Input Scanner scans up to 50 1-wire or 25 2-wire inputs. Upper scan limit selectable at front panel. Channel

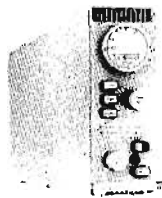

2481A, 2480A

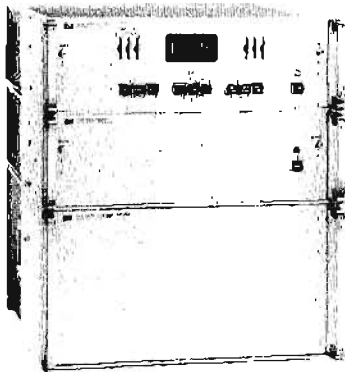

2911A, B, C

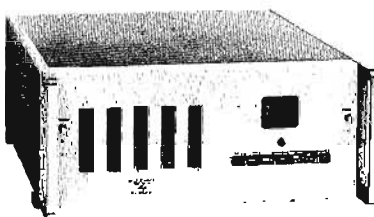

2901A



2900B



CONTINUED **DATA SYSTEM ELEMENTS**  
Instrumentation for system benefit



**DIGITAL SYSTEM ELEMENTS**

being monitored is indicated by in-line visual display and 4-2-2-1 BCD output. Maximum scanning rate is 25 channels/second. Panel height 5¼" (133 mm). Price 2900B, \$1,420.

2515A Digital Scanner transmits digital data from multiple digital measuring instruments to a single recording device at a rate up to 10 sources per msec. The 2515A provides for scanning, in programmable sequence, of electronic counters, nuclear scalars, digital voltmeters or complete digital clocks. It couples their outputs into a single recording device such as a digital recorder, card or tape punch or magnetic tape recorder.

The basic 2515A accepts up to 12 digits of bcd data (10 data digits, 2 source ID digits) from up to 3 sources. Modifications expand this to 6 sources. By bussing scanner output lines, data from 150 or more sources can be transferred to a single recorder. The 2515A interrogates all selected data sources in programmed sequence and transmits this data directly to recorder by solid-state switch. It accommodates a variety of input levels and provides uniform input to recorder. Panel height 5¼" (133 mm). Price 2515A, \$4200.

### Signal converters

2410B AC/Ohms Converter (page 227) used in conjunction with 2401C Digital Voltmeter for measurement of ac voltages and resistances. Converter features floated, guarded input similar to voltmeter. Combined common mode rejection is 110 dB at 60 Hz. 2410B is fully programmable for systems use. Converter function and range information included in voltmeter display and recording outputs. Panel height 7" (177 mm). Price: 2410B, \$2,250.

2411A Guarded Data Amplifier (page 227). This floated and guarded amplifier provides the 2401C Integrating Digital Voltmeter with a full-scale input of  $\pm 10$  mV, overranging to  $\pm 30$  mV. Ideal for measurements of thermocouples, strain gage bridges and other low-level signal sources. Input impedance is greater than  $10^{10}$  ohms. Combined common mode rejection with 2401C is 134 dB. 2411A features very low noise and zero drift, short settling time for fast data sampling. Panel height 3½" (88 mm). Price: 2411A, \$1200.

### Analog-to-digital converters

2401C Integrating Digital Voltmeter (page 225). Features floated and guarded input and is average-reading, leading to an effective common mode noise rejection better than 140 dB at all frequencies, including dc. Noise problems with grounded, low-level transducers are eliminated with the 2401C. All operating functions may be controlled manually or by external contact closures to ground, enabling it to be used on the bench or in systems applications. BCD outputs provided for digital recording or comparison. Panel height 7" (177 mm). Price: 2401C, \$3,950.



2515A

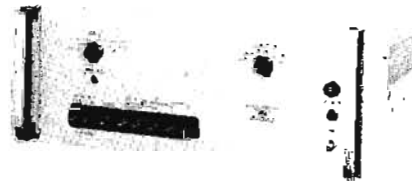

2410B



2411A

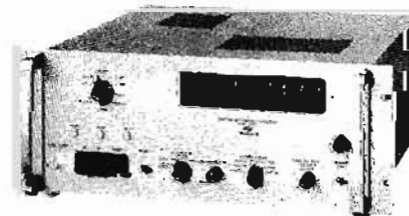

2401C

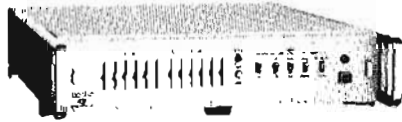

2539A

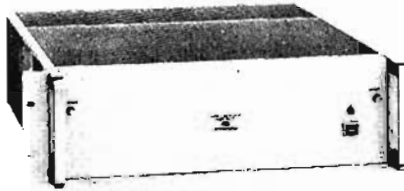

2417A

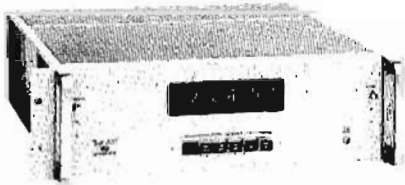

2509A

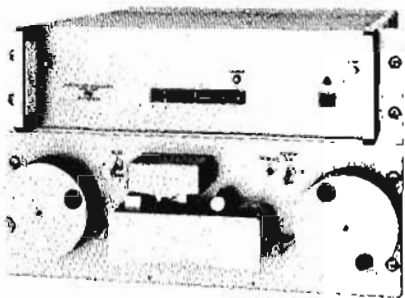

2560A

#### Auxiliary equipment, programmers

2539A Digital Comparator compares BCD information against single or dual preset limits, providing (respectively) Hi/Go/Lo lamp indications and electrical outputs. Comparisons take less than 3 msec. Instrument can be operated either manually or by external signals. The 2539A provides for 12 different comparison conditions, handles any combination of limit relative magnitudes and signs likely to be encountered in practical measurement situations. All solid state, features data storage for fast system operation. Panel height  $3\frac{1}{2}$ " (88 mm). Price 2539A, \$1,850 for 4-digit comparison, \$1,950 for 5-digit, \$2,050 for 6-digit.

2417A Data Linearizer. Arithmetic conversion of electrical values produced by transducers into familiar units such as rpm, psi, degrees C or F, is usually accomplished after the measurement either with a computer or manually using charts or tables. The 2417A permits direct display and recording of transducer outputs in engineering units at the time of measurement. Corrections provided are scale factoring, transducer zero off-set and linearization. Readout is annunciated at the 2401C Digital Voltmeter. Digital techniques are employed and the capability introduces no significant error into the system accuracy. Panel height  $5\frac{1}{4}$ " (133 mm). Price: 2417A, \$2,650.

2509A Digital Clock is a precision time source used to supply time information to the data system and initiate measurements at predetermined intervals. Time-of-day is available visually and as an electrical output for connection to a recorder. It supplies time information on demand, without ambiguities due to time changes, permitting associated system to operate independently of clock. The instrument is all solid-state, features pushbutton selection of timing outputs at intervals from 1 second to 1 hour. Time reference derived internally from line frequency or from external 1 pps signal. Provision for 100 kHz external reference optional. Easy manual or remote time set. 4-2<sup>2</sup>-2-1 BCD output. Panel height  $5\frac{1}{4}$ " (133 mm). Price: 2509A, \$2,250.

2911C Programmer is designed to operate with the 2911 Guarded Crossbar Scanner. It offers a convenient means of storing and selecting, by channel groups, the system measurement function (e.g., ac/dc voltage, resistance, frequency) and input range, and also enables channels to be skipped individually. Programming is accomplished by inserting diode pins into internal program boards which are easily accessible from the front panel while the instrument is installed in position. 2911C is all solid-state. Panel height  $5\frac{1}{4}$ " (133 mm). Price: 2911C, \$3,425.

2560A Programmer reads instructions punched on paper tape and governs all aspects of system operation. Programmer selects measurement functions, scanner input channel on a specific channel or group-channel basis and controls

CONTINUED **DATA SYSTEM ELEMENTS**  
Instrumentation for system benefit

**IBM** **DIGITAL SYSTEM ELEMENTS**

data recording. Also programs system comparator and governs data recording in accordance with comparison result. Optional tape-search capability allows programmer to search for different instructions on tape in response to comparison results and/or time information supplied by a digital clock. Operation of the entire system can be changed simply by changing programming tape. 2560A is all solid-state. Panel height 5 $\frac{1}{4}$ " (133 mm). Price: 2560A, \$3,380 to \$5,125, depending on options. Price includes tape reader.

2116A Computer (page 88) provides a method for sophisticated system control. Timing and sequencing of the input scanner, measuring and recording devices is programmed by the computer. It also performs the functions of limit comparison and code conversion usually accomplished by separate individual instruments. Arithmetic manipulation of data such as solving of single and multiple variable equations on stored or measured inputs from one or more channels is easily practical when the system includes this device. Convenience of operation and system programming and input/output flexibility are paramount in the design of this system element. Panel height 3 $\frac{1}{2}$ " (798 mm). Price 2116A with 4096 word memory. \$22,000.

#### Output couplers, recorders

2545 Coupler operates with Teletype BRPE 11 Tape Punch (Tally 420 Punch optional). Recording speed 110 characters/second. Data storage feature permits new reading during recording cycle, for faster data sampling. Standard model accepts 10 input characters, produces IBM 8-level code. Up to 16 input characters and other 5 to 8-level output codes optional. Simultaneous printer operation optional. All solid-state. Panel height 8 $\frac{3}{4}$ " (222 mm). Price (including punch): 2545, \$3,900.

Tape punch and spooler available in rack-mount form (2545C). Panel slides up for access. Assembly rolls forward for easy tape loading and unloading. Panel height 12 $\frac{1}{4}$ " (310 mm). Add \$800 to price of 2545 set.

2526 Coupler operates with IBM 526 Summary Punch. Standard model accepts 10 input characters, stores data to allow new reading during recording cycle for faster system operation. Format flexibility through IBM patchboard. Optional simultaneous operation of printer. All solid-state. Panel height (incl. junction panel) 10 $\frac{1}{2}$ " (266 mm). Price: 2526, \$3,100.

2546 Coupler operates with Kennedy 1406 Incremental Tape Recorder. (Optionally Kennedy 1506 or DS 3706). Records in standard IBM 7-channel NRZI code with tape format completely flexible as controlled by a diode pinboard. Accepts up to 12 BCD characters and records at 400 characters/second, asynchronous. Data storage permits fast data sampling. Simultaneous printer operation optional. All solid state. Panel height 5 $\frac{1}{4}$ " (133 mm) for coupler 12 $\frac{1}{4}$ " (310 mm) for tape deck. Price: 2546, \$8,150.

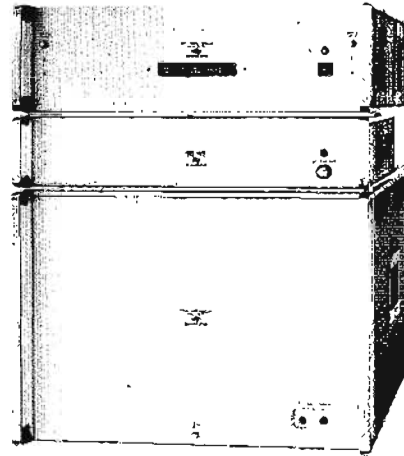

2545A



2526A



2546A

## DATA ACQUISITION



## DATA ACQUISITION SYSTEMS

Rapid, accurate measurement of analog signals  
2010 Series

### Features

- Accurate digital measurements of dc inputs down to a few millivolts
- Frequency measurements to 300 kHz
- Optional ac voltage measurements from 50 Hz to 100 kHz
- Optional resistance measurements from 100 ohms to 10 megohms full scale
- Average-reading characteristics minimizes superimposed noise effects

### Application

Dymec Data Acquisition Systems measure analog data derived from a number of sources, and display and record this information in digital form. To present the recorded information in its most useful medium, systems are available with a choice of output recording devices. For direct reading by the operator, a printout on paper tape is provided. If the data is to be entered into a computer, it may be recorded on punched paper tape, punched cards, or digital magnetic tape, as appropriate. A standard addition to the basic system allows measurements to be compared digitally against preset upper and lower limits; the comparison result is indicated visually and is included in the data recording. Another standard addition enables time-of-day to be recorded along with the measurement data, and also permits the gathering of data at predetermined time intervals.

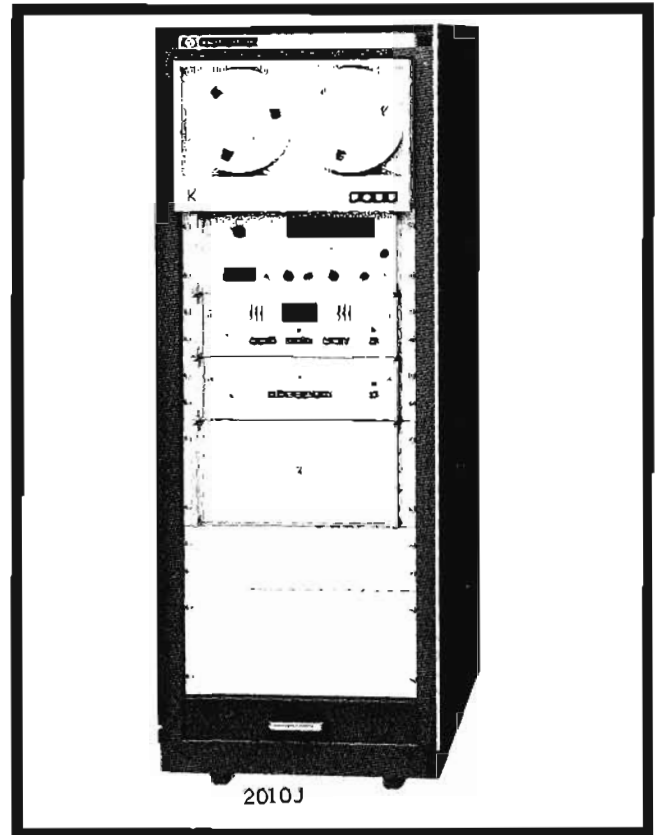

2010J

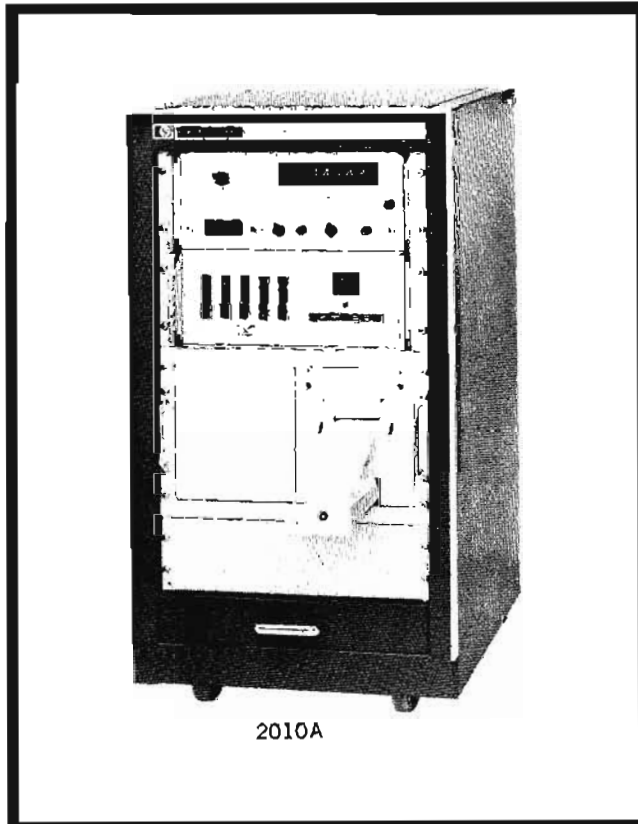

2010A

Typical inputs are dc and ac voltages, frequencies and resistances. It follows that Dymec Data Acquisition Systems may therefore be employed to measure any combination of physical parameters that are convertible by transducers to these analog forms. Some examples are temperatures, pressures, velocities, accelerations, weights, and displacements.

Digital techniques are used to obtain high measurement resolution and accuracy, high sampling speeds, and the ability to transfer the measured information easily to a wide variety of digital recording devices. In particular, the 2010 Series of data acquisition systems utilizes the 2401C Integrating Digital Voltmeter as the digitizer. This instrument features a floated and guarded input, permitting accurate low-level measurements in the presence of severe common mode noise—a common problem with grounded transducers.

By virtue of a large choice of standard optional features, the 2010 systems can be tailored to suit a wide range of analog measurement applications, and it is most likely that your requirements can be met by a completely standard, proven system. Meeting your needs with standard equipment means reliability, good delivery and cost savings for you. If a standard 2010 system does not exactly match your requirements, Dymec will supply modified versions, or advise other systems in the Dymec line that may be closer to your needs. Principal characteristics of the 2010 Series systems are given in the specifications.

## Specifications, 2010 Series

### DC voltage measurements

#### Noise rejection:

Overall effective common mode rejection (ratio of common mode signal to its effect on digital display): 2010A, B, E, H: 100 dB at all frequencies, 100 dB at dc; 2010C, D, F, J: 130 dB at all frequencies, including dc (0.1 sec sample period); amplifier option reduces CMR by less than 6 dB.

Common mode rejection (ratio between common mode signal and voltage it superimposes on source): 2010A, B, E, H: 85 dB at 60 Hz 100 dB at dc; 2010C, D, F, J: 110 dB at 60 Hz 130 dB at dc, with 1000 ohms between ground and low side of input (resistances up to 10 k).

Superimposed noise rejection (ratio of superimposed noise to its effect on digital display): on 0.1 sec sample period, noise rejection is infinite to 60, 120, 400 Hz and all common noise frequencies.

**Voltage ranges:** five ranges from 0.1 V to 1000 V full scale; polarity sensed and indicated automatically; amplifier (option) provides 10 mV full scale; auto-ranging available.

**Overranging:** to 300% of full scale except on 1000 V range; input attenuator switched to 1000 V range if overload exceeds 310%; reset automatically as scanner advances to next channel, or manually.

**Input impedance:**  $10^7$  ohms on 10, 100, 1000 V ranges; 1 megohm on 1 V range; 100 k on 0.1V range;  $10^8$  ohms with amplifier option for inputs up to 10 V.

**Resolution:** three fixed sample periods of 0.01, 0.1 and 1 sec.

**Internal calibration source:**  $\pm 1$  V internal standard provided for self-calibration; voltage reference is derived from temperature stabilized zener diode; drift less than  $\pm 0.006\%$  in 6 months; internal standard may be compared against external standard; factory adjusted to better than  $\pm 0.002\%$  absolute accuracy at 25°C; temperature effect  $\pm 0.001\%$  /°C, 10 to 40°C.

**Overall dc accuracy for 2010 Systems:** (specifications hold for  $\pm 10\%$  line voltage change).

**Basic accuracy:**  $\pm 0.01\%$  reading  $\pm 0.005\%$  full scale  $\pm 1$  digit (0 to full scale);  $\pm 0.025\%$  reading  $\pm 1$  digit (at 3X full scale); applies to all ranges, 6 months operation; assumes daily calibration against internal standard, operating at 25°C.

**Temperature coefficient:**  $\pm 0.0015\%$  reading per °C, 10 to 50°C, when calibrated against internal standard at operating temperature;  $\pm 0.002\%$  reading  $\pm 0.0005\%$  full scale per °C (0.1 V range);  $\pm 0.002\%$  reading  $\pm 0.0002\%$  full scale per °C (1/10/100/1000 V ranges), when not calibrated at operating temperature, over range 10 to 50°C.

### Frequency measurements

**Range:** 5 Hz to 300 kHz.

**Sample period:** 0.01, 0.1 or 1 sec.

**Accuracy:**  $\pm 1$  digit  $\pm$  time base accuracy; stability of internal time base,  $\pm 2/10^6$  per week over  $\pm 5^\circ\text{C}$  temperature range; temperature effect,  $\pm 100/10^6$  over 10 to 50°C range; rear BNC and switch provided for external frequency standard; level, 2 V peak to peak into 1.2 k.

**Input sensitivity:** 0.1 to 100 V rms (front-panel adjustment 0, or 1 V negative pulses, 2  $\mu\text{sec}$  min. width)

**Impedance:**  $10^6$  ohms shunted by 250 pF.

### AC voltage measurements (optional)

#### Noise rejection

**Common mode rejection:** 2010A, B, E, H: 75 dB at 60 Hz 2010C, D, F, J: 100 dB at 60 Hz with 1000 ohms between ground point of source and low side of system input.

**Voltage ranges:** same as for dc voltage measurements (optional amplifier not applicable); max. input, 750 V peak.

**Input impedance:**  $10^6$  ohms on all ranges, shunted by 400 pF.

**Accuracy (steady state):** 50 Hz to 10 kHz  $\pm 0.05\%$  full scale  $\pm 0.1\%$  of reading; 10 kHz to 30 kHz  $\pm 0.06\%$  full scale  $\pm 0.2\%$  of reading; 30 to 100 kHz  $\pm 0.1\%$  full scale  $\pm 0.2\%$  of reading.

**Transient error:** normal response (frequencies below 400 Hz) output settles to  $\pm 0.25\%$  of final value in 550 msec; fast response (frequencies above 400 Hz); output settles to  $\pm 0.25\%$  of final value in 200 nsec.

### Resistance measurements (optional)

**Noise rejection:** resistance measurement circuit is guarded; ac common mode pickup on resistance measurements can be reduced to negligible level by connecting guard to grounded end of test resistance.

**Ranges:** six ranges from  $\pm 100/10^7$  ohms full scale.

**Overranging:** to 300% of full scale on all ranges except 10 megohm; input attenuator switched automatically to  $10^7$  ohms range if overload exceeds 310%; reset automatically as scanner advances to next channel or manually.

### Resistance measurement accuracy

Specifications hold for  $\pm 10\%$  line voltage change, 6 months operation. Assume daily calibration against internal standard.

RANGE	MEASUREMENT CURRENT	RELATIVE HUMIDITY (AT 40°D)			
		70%		95%	
		= % rdg	= % fs	= % rdg	= % fs
0.1 k	10 mA	.02	.51	.02	.51
1 k	1 mA	.02	.06	.02	.06
10 k	100 $\mu\text{A}$	.02	.01	.03	.01
100 k	10 $\mu\text{A}$	.02		.12	
1 M	1 $\mu\text{A}$	.03		1.0	
10 M	1 $\mu\text{A}$	.12		10	

Figures do not include  $\pm 1$  count display ambiguity.

Overrange accuracy: convert % fs error to % rdg, add to existing % rdg error.

Temperature effect: .005% rdg = .001% fs, not calibrated at operating temp.

(Per °C, 10 to 50°C) .004% rdg = .0005% fs, when calibrated at operating temp.

Internal settling delay of 100ms reduces response error to .005% rdg.

#### General

**Display:** 6-digit in-line readout; polarity, decimal point measurement units, and overload; storage holds display between readings, switch permits display during count if desired; scanner provides in-line digital indication of channel being monitored.

**2010 Series Data Acquisition Systems Table**

HP model	2010A	2010B	2010E	2010H	2010C	2010D	2010F	2010J
Number of input channels	stepping-switch scanner; up to 25 3-wire inputs; to 100 channels with slave scanners				guarded crossbar scanner; up to 200 3-wire inputs; also accepts 100 6-wire, 200 3-wire and 600 1-wire inputs			
Programming	self-programming capability permits measurement of mixed types and levels of signals				pinboard or punched tape programmer may be added to handle mixed types and levels of signals			
Effective common mode noise rejection	105 dB				130 dB			
Measurement speed (max. dc volts meas.)	5 channels per sec	10 channels per sec	1 channel per sec	10 channels per sec	5 channels per sec	9 channels per sec	1 channel per sec	18 channels per sec
Output	printed paper tape	perforated paper tape	punched card (on IBM 526)	digital magnetic tape	printed paper tape	perforated paper tape	punched card (on IBM 526)	digital magnetic tape
Price	\$8,310	\$10,225	\$9,425	\$14,475	\$10,660	\$12,500	\$11,700	\$16,750
Options	time of day; ac/ohms measurements; 10 mV full-scale sensitivity; limit comparison; programmers							

## DATA ACQUISITION SYSTEMS



## DATA ACQUISITION SYSTEM

Measure multiple dc V or ac V economically  
2013 Series

Dymec 2013 Series Data Acquisition Systems sequentially scan many analog sources, convert the data to digital form and measure and record it digitally. Ten different individual systems comprise the series. All 2013 Systems use the HP Model 3440A Digital Voltmeter (page 220) as the analog-to-digital converter. All provide a visual readout and permanent record of the measurement and channel identification. For descriptions of basic system functions, see page 78.

Advantages common to all 2013 Systems, arising from use of standard, proven system elements in fully engineered systems; lowest cost, quick delivery, completely specified system performance, high reliability.

For maximum usefulness, systems in the series differ in input accommodations and output recording devices. Models 2013A and J record on printed paper strip. Each printed line contains the data for one system input channel, including channel identification, data function (polarity) and indication of decimal point location. 2013B and K provide a perforated tape output, using an output coupler and a Friden SP-2 Tape Punch, to produce tape punched in standard IBM 8-level code. Models 2013C and L log typewritten records, using a coupler and an IBM Model B output writer. Records up to 25 channels per line. 2013D and 2013M produce electrical outputs suitable to drive IBM 024 or 026 Card Punch equipment, incorporating a coupler to serialize the binary-coded decimal output of the digital voltmeter, and present it in a form suitable for the card punch.

Many standard options are available. Any 2013 System will record 6 digits of time by adding a 24-hour digital clock. Options also provide input ranges of 100 mV and 1 V auto-ranging and ac measurement capability.

### Specifications

#### DC voltage measurements

**Voltage ranges:** 10, 100, 1000 V full scale (max. input 750 V); optionally 0.1, 1, plus above.

**Overranging:** 5% all ranges except 1000 V, indicated in display window and recorded.

**Range selection:** manual at front panel standard all models; optionally manual or automatic for all or the upper three voltage ranges.

**Auto-range change points:** upwards at decade, down at 9% full scale.

**Input impedance:** 10.2 megohms all ranges.

**Resolution:** 4 digits.

#### AC voltage measurements (optional)

**Ranges:** 1, 10, 100, 1000 V full scale (max. input 300V rms).

**Overranging:** 5% all ranges except 1000 V.

**Range selection:** manual.

**Frequency range:** 50 Hz to 100 kHz.

**Input impedance:** 1 megohm shunted by 500 pF.

**Accuracy:** 50 Hz to 50 kHz,  $\pm 0.3\%$  of reading  $\pm 0.001$  V  $\pm$  dc accuracy (above); 50 kHz to 100 kHz  $\pm 0.75\%$  of reading  $\pm 0.001$  V  $\pm$  dc accuracy.

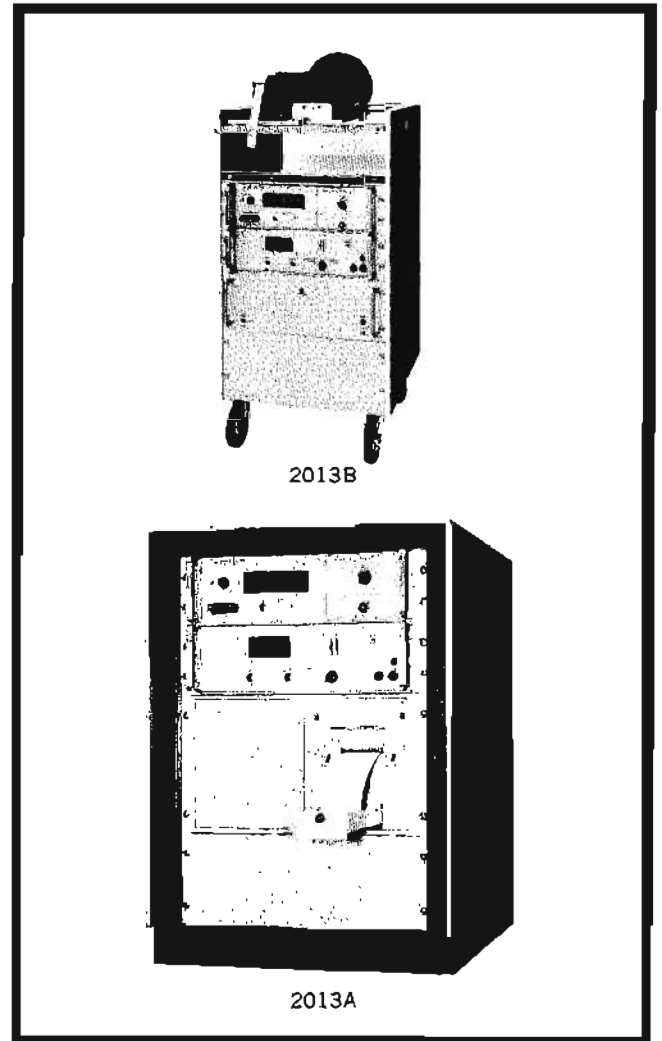

#### General

**Input:** single-ended (signal low must be connected to ground either at source or voltmeter) all models: 2013A through D, 25 switched wire-pairs or 50 single wires; 2013J through M, 25 3-wire shielded pairs.

**Prices:** 2013A, \$4495; 2013B, \$5410; 2013C, \$5645; 2013D, \$4420; 2013J, \$4850; 2013K, \$5765; 2013L, \$6000; 2013M, \$4775.

**Options:** 10 to 1000 V auto/manual range selector, add \$135; 0.1 to 1000 V auto/manual range selector, add \$450; time recording once each channel (2013A only), add \$1775; rack mount Friden tape punch (2013B) add \$800, time reading once each scan \$1980.

**Accessories:** **Cabinets:** 5060-2445 and 5060-2446 include power strip, switch, indicator lamp and cord, caster base, fan assembly, rear door, instrument-mounting rails and blank panels for unoccupied space, 5060-2445, \$565; 5060-2446, \$735; 5060-2451 same style, but includes only rails and blank panels \$300; 5060-3760 is 1117A Testmobile (page 304) modified to accept instrument mounting rails, \$200.

# DATA ACQUISITION SYSTEMS

## High accuracy digital data system

### 2015 Series



# DATA ACQUISITION SYSTEMS

Dymec Data Acquisition Systems are designed to measure analog data derived from a number of sources, and to display and record this information in digital form. To present the recorded information in its most useful medium, systems are available with a choice of output recording devices. For direct reading by the operator, a printout on paper tape is provided. On the other hand, if the data is to be entered into a computer, it may be recorded on punched paper tape, punched cards, or digital magnetic tape, as appropriate.

Exceptionally high accuracy is provided by the 2015 systems through a new measuring technique employed in the H01-3460A Digital Voltmeter. This voltmeter uses a combination of the classic high-accuracy potentiometric technique, combined with integration to average out disturbances on the dc signal. Accuracy is within  $\pm .004\%$  of reading ( $\pm 2$  counts in the least significant displayed digit) over an ambient temperature range of 20 to 30°C. Readings are displayed to 5 digits of resolution (plus an overrange digit).

The H01-3460A is guarded, such that common mode noise arising from circulating ground currents is greatly attenuated before reaching the voltmeter's input terminals. For example, common mode noise at 60 Hz is reduced by 85 dB (overall system specification).

Additionally, the H01-3460A reduces noise superimposed on the signal by averaging. Cancellation of the usual hum frequencies of 60 and 120 Hz is virtually infinite. Combined, guarding and averaging provide an effective common mode rejection of 105 dB for any noise frequency. This figure corresponds to an error of less than  $6 \mu\text{V}$  for 1 volt of common mode noise.

### General Specifications

#### Input circuit

Floated and guarded signal pair for each channel. Signal pair and guard may be operated up to 500 V above chassis ground.

#### Display

6-digit Nixie® readout. Polarity, decimal point, measurement units, and overload condition indicated automatically.

Storage feature holds display between readings. Scanner displays channel number being monitored.

® Burroughs Corporation.

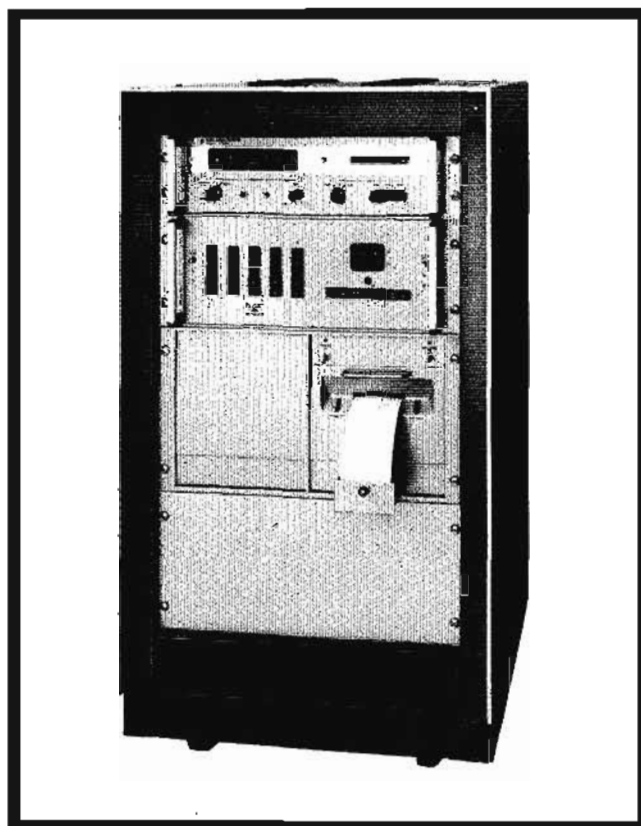

#### Operating modes

**On demand logging (single scan):** system makes one measurement scan consisting of all selected channels on push-button or external command; **Continuous Logging:** System repeats measurement scan continuously. No external triggering required. **Single-Step Operation:** System advances channel by channel on pushbutton command. **Single-Channel Monitoring:** System is stepped manually to desired channel, then voltmeter is set to sample and record continuously.

#### Output recording

**All systems record:** Channel number (2 digits); Function (1 char.); Measurement (6 digits); Range (1 digit).

In addition punched tape recording includes end-of-word character, and magnetic tape recording includes 2 blank characters at end of word.

### DY-2015 Series Data Acquisition Systems

	2015A	2015B	2015E	2015H	2015D	2015D	2015F	2015J
Number of input channels	Stepping-switch scanner. Up to 25 3-wire inputs; to 100 channels with slave scanners.				Guarded crossbar scanner. Up to 200 3-wire inputs. Also accepts 100 5-wire, 200 3-wire and 600 1-wire inputs.			
Programming	Self-programming capability permits measurement of mixed types and levels of signals.				Programmer may be added to handle mixed types and levels of signals.			
Measurement speed (Maximum, dc volts meas.)	5 channels per sec.	7 channels per sec.	1 channel per sec.	7 channels per sec.	5 channels per sec.	9 channels per sec.	1 channel per sec.	12 channels per sec.
Output	Printed paper tape	Perforated paper tape	Punched card (on IBM 526)	Digital magnetic tape	Printed paper tape	Perforated paper tape	Punched card (on IBM 526)	Digital magnetic tape
Price	\$8,160	\$10,075	\$9,275	\$14,325	\$10,510	\$12,350	\$11,550	\$16,600





## COMPUTER

Add computation to digital measuring systems

Model 2116A

### Hardware advantages:

- 16 bit word length
- 16 individually buffered I/O channels with automatic priority interrupt
- 59 parallel, interrupting channels with priority control
- 4096 word memory, expandable to 8192 words with optional plug-ins
- 1024 word page size 2048 words directly addressable
- 1.6  $\mu$ sec memory cycle time
- Dual, directly addressable accumulators
- Wide environmental operating tolerance
- 68 basic one-word instructions

### Software features:

- Software package fully operable with 4096 word memory
- Extended ASA Basic FORTRAN Compiler
- Modular, flexible I/O control system—allows device-independent programming
- Linking, relocating loader
- Assembly language programs may be linked to FORTRAN-generated code
- Utility routines—software configurator, debugging package, hardware diagnostics

The Hewlett-Packard Model 2116A Computer is a versatile general-purpose digital computer designed to add computation capability to Hewlett-Packard data measuring and recording systems. The logical design and software follow conventional

standards of computer usage and notation so that the 2116A may also be used as a free-standing device or in other types of systems. The hardware and software permit interfacing of real-time devices running asynchronously with respect to a program.

The basic hardware package includes the processor unit (main frame) with 4096-word ferrite core memory. Standard options are available (1) to extend the capabilities of the basic instrument, and (2) input/output (I/O) options to add to the facilities of the basic 2116A Computer. I/O options are listed in table on page 91. Standard software packages are supplied when input/output capability is included as part of a purchased system.

Standard computing data acquisition systems are available in specified configurations, which combine Hewlett-Packard digital scanning, measuring, and recording equipment with the 2116A Computer. An example of this type of system is illustrated at left. In this system the computer is programmed to exercise control over the data taking process and to perform computations on data measured by the system. Capabilities of available instruments include measurement of ac or dc voltages, resistances, frequencies, time periods, temperatures, gas pressures, nuclear events, etc., and scanning of multiple inputs using different scanning modes including specific channels on computer command. The functions of some instruments such as linearizers, comparators, scanner programmers, and output couplers are performed by the 2116A Computer.

Additionally, special systems may be supplied to perform specific functions and tailored to individual requirements. Hewlett-Packard and other OEM instrumentation capabilities are utilized in this type system.

### Input/output system

The flexible addition of input/output devices is a major user feature of the 2116A Computer. It can operate with up to 16 input/output devices in its basic configuration; up to 55 channels are available.

The I/O system is simplicity itself. Peripherals can be added or deleted, and service priorities changed, on a plug-in basis. No wiring changes are involved. Even the software is modular—a software configurator allows the user to change his operating system with minimum programming.

Interface circuitry to run a specific peripheral is contained on one or more cards that plug into any I/O slot in the 2116A. All interface cards have identical pin assignments, and the computer backplane is uniformly wired. Interconnecting cables mate directly with the I/O interface cards reducing the number of mechanical connections in the system, and minimizing the possibility of noise injection into the backplane. All peripherals draw their own power directly from the power line; the interface cards are powered from the computer's internal power supply.

Multichannel priority interrupt capability is included as a standard hardware feature in the 2116A—an interrupt channel associated with a unique memory location is provided with each I/O interface. Priority level for an input/output device is determined by the I/O slot into which its interface card is installed, so priority levels can be rearranged simply by moving cards into different slots. Peripherals can also be programmed "in" or "out" by enabling or disabling the control bit associated with its I/O address. The interrupt system also can be bypassed and all peripherals run under direct program control.



The 2116A multi-channel interrupt capability significantly reduces the time involved in processing interrupt routines. In a multi-device system, the first useful instruction on a higher priority device is executed in less than 7  $\mu$ sec; with one I/O device, response time is less than 3  $\mu$ sec. The multi-channel interrupt feature and fast response promote efficient operation in a real-time environment, as in instrumentation systems.

I/O options for the computer are listed in the table on page 91. In most cases the option includes the peripheral as well as the interface cards and interconnecting cables. An example is the HP 2737A Punched Tape Reader, its interface card and cable. In some instances where the peripheral may be associated with more than one interface (or be subject to optional modifications of its own), it is not included in the option. An example is the 2401C Integrating Digital Voltmeter, which requires one interface to transfer its data into the computer, and another interface to accept function commands from the computer.

### Machine organization

The HP 2116A Computer has nine internal registers; eight of these are flip-flop (integrated circuit) registers, and the ninth consists of toggle switches for manual data entry. Contents of all but one of the flip-flop registers are available to the programmer and are displayed on the front panel. (See specifications for definition of registers.)

### Panel controls

**Switch register:** 16 toggle switches for manually entering information into the computer.

**Power:** controls power input to computer. System is power fail-safe; contents of memory are not affected by switching power off and on.

**Loader:** toggle switch which protects the block of memory (last 64 locations) which are normally occupied by the Basic Binary Loader.

**Preset:** momentary switch to preset computer to fetch phase, turns off interrupt system and all I/O control bits, sets I/O flag bits (Resets optional parity error indication.)

**Run:** momentary switch to start operation at current state of computer.

**Halt:** momentary switch to stop computer operation at end of current phase.

**Load memory:** momentary switch to store contents of Switch Register into memory location specified by address in M-Register.

**Load A, load B:** momentary switches to transfer contents of Switch Register into A or B Register, respectively. Computer's phase status is not altered.

**Load address:** momentary switch to transfer contents of Switch Register into both P and M Registers, directing computer to desired address.

**Display memory:** momentary switch to display, in T-Register, contents of location specified by address in M-Register.

**Single cycle:** momentary switch to execute one machine cycle.

### Instructions

The HP 2116A has 68 basic one-word instructions.

These instructions are grouped in three types, described in the Instruction Repertoire Table. Combinations of the Register Reference microinstructions extend the total of different one-word, single cycle instructions to over 1000.

### Instruction repertoire

Type	Mnemonic	Description	Time Microsec
Memory Reference Instructions (14)	AND	'And' (M) to A; result in A	3.2
	XOR	Exclusive 'or' (M) to A; result in A	3.2
	IOR	Inclusive 'or' (M) to A; result in A	3.2
	JSB	Jump to subroutine	3.2
	JMP	Jump, unconditionally	1.6
	ISZ	Increment (M); skip if result zero	3.6
	ADA/B	Add (M) to A or B; result in A or B	3.2
	CPA/B	Compare (M) with A or B; skip if not equal	3.2
	LDA/B	Load (M) into A or B	3.2
STA/B	Store (A) or (B) into M; A, B unchanged	3.2	
41 Shift-Rotate Group (20)	NOP	No operation	All 1.6*
	CLE	Clear E-Register	
	SLA/B	Skip if least significant bit of A/B is zero	
	A/BLS	A or B arithmetic left shift one bit	
	A/BRS	A or B arithmetic right shift one bit	
	RA/BL	Rotate A or B left one bit	
	RA/BR	Rotate A or B right one bit	
	A/BLR	A or B left shift one bit (sign cleared)	
	ERA/B	Rotate E right one bit with A or B	
	ELA/B	Rotate E left one bit with A or B	
A/BLF	Rotate A or B left four bits		
Register Reference Instructions Alter-Skip Group (19)	CLA/B	Clear A or B	All 1.6*
	CMA/B	Complement A or B (ones complement)	
	CCA/B	Clear, then complement A or B (sets A/B to -1)	
	CLE	Clear E-Register	
	CME	Complement E-Register	
	CCE	Clear, then complement E-Register (sets E to 1)	
	SEZ	Skip if E-Register is zero	
	SSA/B	Skip if sign of (A) or (B) is zero (A/B positive)	
	SLA/B	Skip if least significant bit of (A) or (B) is zero	
	INA/B	Increment (A) or (B) by one	
SZA/B	Skip if (A) or (B) is zero		
RSS	Reverse skip sense		
Overflow (4)**	STO	Set arithmetic overflow	All 1.6
	CLO	Clear arithmetic overflow	
	SOC	Skip if arithmetic overflow clear	
	SOS	Skip if arithmetic overflow set	
I/O Instructions (13)	HLT	Halt program	All 1.6
	STF	Set flag bit of selected channel	
	CLF	Clear flag of selected channel	
	SFC	Skip if flag clear	
	SFS	Skip if flag set	
	MIA/B	Merge contents of selected channel into A or B (inclusive 'or')	
	LIA/B	Load contents of selected channel into A or B	
	OTA/B	Output from A or B to selected channel	
STC	Set control bit of selected device		
CLC	Clear control bit of selected device		

\*Register Reference Instructions can be combined to execute in 1.6  $\mu$ sec. This allows, for example, shifts and rotations up to 8 places in 1.6  $\mu$ sec total.

\*\*Coded under I/O group.

(M) = Contents of memory location M.

### Programming

The HP 2116A Computer is supported by a full range of software, furnished on punched paper tape. The following software packages are supplied:

- FORTTRAN compiler
- Assembler
- Symbolic editor
- Basic control system
- Hardware diagnostics

All software packages will run in the minimum 2116A Computer system configuration — 4K memory and Teleprinter I/O. Programs prepared with the compiler or assembler are essentially independent of hardware input/output configuration; the Basic Control System links these "device-free" programs to software elements which in turn drive the peripherals. The Basic Control System is made up to suit a particular system. An auxiliary software package allows user to change Basic Control System to fit different input/output arrangements.



## Word formats

## Memory Reference Instructions

15	14	13	12	11	10	9	8	7	6	5	4	3	2	1	0
D/I	Instruction					Z/C	Memory address								

## Register Reference Instructions

15	14	13	12	11	10	9	8	7	6	5	4	3	2	1	0
Reg. Ref.-Instr.				A/B	SR/AS	Micro-Instruction									

## Input/Output Instructions

15	14	13	12	11	10	9	8	7	6	5	4	3	2	1	0
I/O Instr.		A/B	Instruction				I/O Select Code								

## Full Address

15	14	13	12	11	10	9	8	7	6	5	4	3	2	1	0
D/I	Page Address					Word Address									

D/I Direct/Indirect; Z/C Page Zero/Current Page; A/B Register Identifier; SR/AS Shift-Rotate/Alter-Skip Identifier

## Data, Single precision, fixed point

15	14	13	12	11	10	9	8	7	6	5	4	3	2	1	0
Sign	Integer														

## Data, Double Precision, fixed point (31 bits &amp; sign.)

15	14	-----													0	15	-----													0
Sign	Most Significant Bits															Least Significant Bits														

Data, Single Precision, Floating Point  
(Magnitude, 23 bits & sign. Exponent, 7 bits & sign.)

15	14	-----													0	15	8	7	-----	1	0
Mag Sign	Magnitude, Most sig. bits															Mag., least sig. bits	Ex-ponent	Exp Sign			

**FORTRAN compiler:** Accepts source programs written to ASA specifications for Basic FORTRAN (a standardized form of FORTRAN II). It produces a relocatable machine language object program which can be loaded and executed under control of the Basic Control System. Operable in 4K memory.

**Assembler:** Translates symbolic source language instructions into an object program for execution on the computer. The source language provides mnemonic machine operation codes, assembly-directing pseudo codes, and symbolic addressing. The assembled program may be absolute or relocatable. Source program may be assembled as a complete entity, or divided into several sub-programs, (or a main program and several subroutines) each of which may be assembled separately. The loader of the Basic Control System loads and links relocatable programs; the Basic Binary Loader loads absolute programs.

**Symbolic editor:** A program which enables use of the computer to simplify the correction or updating of an assembly language program or a FORTRAN language program, avoiding the process of manually repunching an entire program.

**Basic Control System:** Provides an efficient loading, input/output control and debugging capability for relocatable programs produced by the HP-2116A Assembler or HP-2116A Compiler. The system is modular in design and may be constructed or modified to fit the user's particular hardware configuration. The following modules are provided.

**Relocating Loader:** Links, initiates execution of relocatable object programs produced by Assembler or FORTRAN Compiler.

**I/O Control:** Provides for general input/output device control and software buffered data transmission between I/O devices and memory.

**I/O Drivers:** Provide the instructions necessary to operate specific input/output devices, and serve as an interface between the I/O Control system and the peripheral devices.

Two other software packages are furnished for the preparation of the Basic Control System. **Prepare Control System:** Combines the Basic Control System component modules together with equipment tables to generate a particular Basic

Control System configuration. **Debugging Routines:** Interpret and execute machine instructions.

**Hardware diagnostics:** Check out memory, arithmetic and logic unit and I/O system including peripherals.



## General specifications

**Type:** general-purpose digital computer, with I/O system and modular software organized for on-line instrumentation systems.

**Memory:**

**Type:** magnetic core.

**Size:** 4096 16-bit word. Expandable to 8192 words with optional plug-in 4K module and associated cards. Maximum size 32,768 words. (Parity bit included in standard stack.)

**Addressing:** memory is organized in 1024-word pages, 2048 words directly addressable.

**Speed:** 1.6  $\mu$ sec. cycle time.

**Loader protection:** last 64 locations of memory reserved for Basic Binary Loader. Front panel switch in 'Protect' position, prevents alteration of contents of these locations.

**Memory parity check (optional):** permits parity checking within memory. Consists of one plug-in card for each 4 k of memory.

**Memory test (optional):** enables memory to be tested independently of program control. Consists of one plug-in card.

**Arithmetic:** parallel, binary, fixed point, two's complement.

**Speed:** (subroutine operations except for Add):

Add	3.2 $\mu$ sec
Subtract	4.8 $\mu$ sec
Multiply	150 $\mu$ sec
Divide	200 $\mu$ sec
Floating point add	700 $\mu$ sec
Floating point subtract	700 $\mu$ sec
Floating point multiply	900 $\mu$ sec
Floating point divide	1.1 ms

**Registers:** (contents except I and S registers displayed by front panel lamps):

**A-register:** accumulator, input/output. (16 bits.)

**B-register:** accumulator, input/output. (16 bits.)

**E-register:** extend register, links A and B register; indicates carry from A or B register. (1 bit.)

**OV-register:** overflow register, indicates overflow from A or B register. (1 bit.)

**T-register:** transfer register, temporarily holds data transferred in or out of memory. (16 bits.)

**P-register:** program counter. (15 bits.)

**M-register:** memory address register, holds address of next memory location to be accessed (15 bits.)

**I-register:** instruction register, decodes memory reference instructions, holds indicators for zero/current page, direct/indirect addressing (6 bits, 10-15.)

**S-register:** toggle switches on front panel for manual data entry. Contents of register indicated by switch positions. (16 bits.)

**Instructions:**

68 basic, one-word instructions, in three types:

- Memory Reference (2-cycle) 14
- Register Reference (1-cycle) 41
- Input/Output (1-cycle) 13

(Register Reference instructions are micro-operations, can be combined to form over 1000 one-word, single-cycle instructions.)

**Input/Output:**

59, 16-bit interrupting channels with priority control utilized through plug-in I/O interface cards (1 per channel); 55 I/O channels; 4 processor options. Main frame accommodates 16 cards. Servicing of interrupt request begins within 3  $\mu$ sec with one I/O channel, 7  $\mu$ sec for highest priority channel in multiple-channel systems.

**Software:**

- Software (punched tape) furnished consists of:
  - Compiler, ASA Basic FORTRAN (Extended)
  - Assembler
  - Symbolic Editor
  - Basic Control System (BCS)
  - Hardware Diagnostics

(BCS is modular, includes configurator to permit adaptation by user to different I/O arrangements. Also includes debug routines).

**Physical specifications**

**Ventilation:** intake on sides and back at bottom, exhaust at top. Air flow 400 cfm. Heat dissipation 5500 BTU/hr.

**Service access:** front panel hinged at left side, permitting front access to input/output connectors, test switches, plug-in circuit boards, and panel wiring. Main chassis slides forward out of cabinet and swings to right. Permits front access to back plane wiring, power supply, fuses, and 115/230 V jumpers.

**Power:** 115/230 V  $\pm$  10%, 50 to 60 Hz. Main unit power consumption with internal supply loaded to capacity by plug-in options, 1600 W maximum.

**Environmental conditions:** operates in ambient temperatures from 0 to +55°C; relative humidity to 95% at 40°C.

**Installation:** fully enclosed for use on bench, or may be mounted in standard 19-inch rack, using adapters furnished. Requires no special wiring, subflooring, or other special installation preparation.

**Dimensions:** 16 $\frac{3}{4}$ " wide, 31 $\frac{1}{2}$ " high, 18 $\frac{3}{8}$ " deep behind panel (425 x 782 x 467 mm).

**Weight:** (with all plug-in options installed): net 230 lbs (104 kg); shipping 330 lbs (150 kg).

**Price:** HP 2116A, \$22,000.

**Input/output options, HP 2116A**

(I/O options, as defined, include coupling cards, interconnecting cable and peripheral; exceptions noted by \*. Each I/O card occupies one address slot in HP 2116A Computer.

I/O Option	Capability	Peripheral	Price	
			230 V/ 60 Hz	116 V/ 60 Hz
Teletypewriter input/output	HP 2116A records on typewriter and/or punched tape, and inputs from keyboard or punched tape	2752A Teletypewriter (modified Teletype ASR-33)	\$2,100	\$2,000
Heavy-duty teletypewriter input/output	Similar to above, except heavy-duty teletypewriter. Recommended where use exceeds 5 hrs/day or 30 hrs/week	2754A Teletypewriter (modified Teletype)	not available	4,600
High-speed punched tape input	2116A inputs from punched tape at 300/characters/sec.	2737A Punched Tape Reader	2,150	2,100
High-speed punched tape input	Similar to option above, but reader equipped with tape spooler	2737B Punched Tape Reader-Spooler	3,150	3,100
Digital voltmeter programmer (2401C)	Enables 2116A to program 2401C Integrating Digital Voltmeter	2401C Integrating Digital Voltmeter *	1,000	1,000
Digital voltmeter programmer (3460A)	Enables 2116A to program HP 3460A Digital Voltmeter	3460A Digital Voltmeter *	1,000	1,000
Crossbar scanner programmer	Enables 2116A to program 2911 Guarded Crossbar Scanner	2911 Guarded Crossbar Scanner *	1,500	1,500
High-speed punched tape output	2116A records on 120 characters/sec tape punch	2753A Tape Punch	4,150	4,150
Incremental magnetic tape output (1200 ft. reels)	2116A records on IBM compatible, $\frac{1}{2}$ inch 7-channel NRZI tape. Bit density 200 bpi, recording speed 400 characters/sec	Kennedy 1406 Incremental Tape Transport	6,400	6,250
Incremental magnetic tape output	Similar to option above, but reel capacity 2400 feet	Kennedy 1506 Incremental Tape Transport	7,650	7,500
Magnetic tape input/output	2116A records on, and reads from, IBM-compatible $\frac{1}{2}$ inch, 7-channel NRZI tape. Bit density 200 bpi	D2020 Tape Unit (with data electronics and operator control panel)	12,600	12,500

I/O Option	Capability	Peripheral	Price	
			230 V/ 60 Hz	116 V/ 60 Hz
Dual-density magnetic tape input/output	Similar to option above, but records and reads at both 200 and 556 bpi	D2020 Tape Unit (with electronics and operator control panel)	15,100	15,000
Time base generator	Generates real time intervals in decade steps from 100 $\mu$ sec to 1000 sec. Used as time tick for software clock		1,400	1,400
Data-phone interface	Interfaces 2116A with Bell System Data Phone service	Bell System Data Set 103A *	—	1,000
Digital voltmeter data interface (2401C)	2116A accepts BCD data output from 2401C Integrating Digital Voltmeter	2401C Integrating Digital Voltmeter *	1,250	1,250
DVM data interface (3460A)	Accepts BCD data output from 3460A Digital Voltmeter	3460A Digital Voltmeter *	1,250	1,250
DVM data interface (3440A)	Accepts BCD data from 3440A Digital Voltmeter	3440A Digital Voltmeter *	1,250	1,250
Counter Thermometer data interface (8 digits)	Accepts data from 8-digit counter and quartz thermometer	5245L Electronic Counter, 2801A Quartz Thermometer *	1,250	1,250
Counter data interface (7 digits)	Accepts BCD data from 7-digit counters	5244L, 5285A Electronic Counters	1,250	1,250
Counter/thermometer data interface (6 digits)	Accepts BCD data from 6-digit counters and quartz thermometer	5201L, 5202L, 5203L, 5232A, 5233L, 5533L Counters. 2800A Quartz Thermometer *	1,250	1,250
Counter/thermometer data interface (5 digits)	Accepts BCD data from 5-digit counters and quartz thermometer	5212L, 5214L, 5223L, 5512A Counters. 2800A Quartz Thermometer *	1,250	1,250
Counter/Thermometer interface (4-digits)	Accepts BCD data from 4-digit counter and Quartz	5211A/B Counter, 2800A Quartz Thermometer *	1,250	1,250

\*not included in I/O option price



The 2017 Series Data Acquisition Systems are an extension of the 2010 systems described on page 84, but are specifically designed for direct reading of transducer measurements. A 2017 system sequentially measures the outputs of a number of transducers, which can be of similar or of mixed types. It displays and records each measurement in the engineering units appropriate to the physical stimulus sensed by that transducer. Systems incorporate a 2417A Data Linearizer (page 80) in conjunction with a 2401C M70 Integrating Digital Voltmeter as the measuring device.

Besides converting each transducer's electrical output to physical units, the 2017 system is capable of compensating for transducer "live" zero and non-linearity.

This compensation is accomplished by introducing an appropriate preset count into the voltmeter's counting decades. Because the voltmeter's display decades are reversible offsets of both polarities can be handled for voltage (and optional resistance) measurements. Correction for transducer non-linearity is accomplished by approximating the transducer's nominal response curve through a series of straight lines, each having a particular slope or scale factor, and an associated intercept on the readout axis equivalent to a display offset. The number of segments, their lengths, slopes and offsets depend on the particular transducer used, the extent of its non-linearity over the specified operating range, and the degree of "curvefit" required.

The basic 2017 systems measure dc voltage and frequency (pulse rate) inputs or if dc voltage inputs are predominantly low-level (below 30 mV), an optional 2411A Guarded Data Amplifier (page 227) can be added to maintain high resolution readings.

AC voltage and resistance inputs are accommodated with a standard optional addition to the basic system. A 2410B AC/Ohms Converter (page 227). Other standard system options permit digital comparison (2539A Digital Comparator, page 82) of the measured signal against pre-determined upper and lower limits, with comparison results indicated visually and in the data recording. Time-of-day can be added, with visual indication and recording in the permanent record, with a 2509A Digital Clock (page 82). Data recording at pre-determined time intervals is accommodated also with this digital clock. System programming options for the 2017C,D,F,J permit control of all system operating and recording functions using diode pin programmers or punched paper tape reading programmers. 2017A,B,E and H Systems contain program facilities as a part of their input scanner.

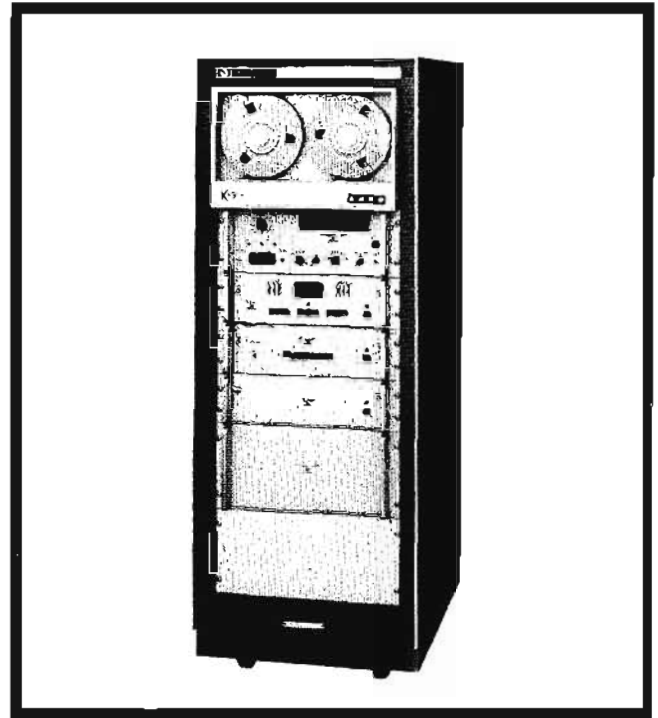

### Specifications, 2017 Series

**Input impedance:** for dc volts measurements, 10  $\Omega$  ohms on 10, 100, and 1000 V ranges, 1 M ohm on 1 V range, 100 k ohm on 0.1 volt range. For ac/ohms 1 M ohm shunted by 400 pF Input circuit: floated and guarded signal pair for each channel. Signal pair and guard may be operated up to 500 V above chassis ground.

**Operating modes:** on demand logging, continuous logging, single step.

**Resolution:** three fixed sample periods of 1, 0.1, and 0.01 seconds.

**Output modes:** printed record on 3" wide paper tape at 5 1/2 lines/sec.; punched tape, 8-level standard IBM code at 110 characters/sec. with Teletype BRPE 11 Punch, punched card, system couples directly to IBM 526 Summary Punch at a maximum speed of 17 characters/sec.; magnetic tape, standard IBM format, NRZI process on 1/2" 7 track tape. with a bit density of 200 bits/inch (optionally, 556 bits/inch) and a recording speed of 400 characters/sec.

**Operating conditions:** ambient temperatures 10 to 50°C relative humidity to 95% at 40°C.

	2017A	2017B	2017E	2017H	2017C	2017D	2017F	2017J
Number of input channels	stepping-switch scanner; up to 25 3-wire inputs; to 100 channels with slave scanners				guarded crossbar scanner; up to 200 3-wire inputs; also accepts 100 6-wire, 200 3-wire and 600 1-wire inputs			
Programming	self-programming capability permits measurement of mixed types and levels of signals				punched tape or pinboard programmer may be added to handle mixed types and levels of signals			
DC voltage ranges	100 mV to 1000 V in 5 ranges; overranging to 300% F.S. on 4 lower ranges; optional 10 mV f.s.							
Frequency ranges	5 Hz to 300 kHz							
Display	5 digits of data plus 1 overrange digit, measurement units, polarity, range, channel number.							
Output	printed paper tape	perforated paper tape	punched card (on IBM 526)	digital magnetic tape	printed paper tape	perforated paper tape	punched card (on IBM 526)	digital magnetic tape
Price	\$11,990	\$13,785	\$12,940	\$17,990	\$13,915	\$15,690	\$14,790	\$19,840

## DIGITAL RECORDERS, ACCESSORIES AND PLOTTING SYSTEMS



## RECORDERS

### Digital recorders

It frequently is expedient or necessary to obtain permanent records of rapidly changing phenomena measured by electronic counters, digital voltmeters or other digital devices. Often it is desirable to relate this permanent data record to time or translate it to analog form. Hewlett-Packard digital recorders and accessories are designed for this purpose.

Hewlett-Packard digital recorders are electro-mechanical devices which provide printed records of digital information from electronic counters, digital voltmeters, scaler-timers, etc. The two major HP digital recorder categories are the 20 line/sec Model 5050A, and the 5 line/sec Models 560A, 561B, 562A and 565A. The common characteristics of all HP digital recorders are: (1) parallel entry (i.e., the input data for all digits must be present at the time printing is commanded); (2) a manual paper advance aids observation of last printout; (3) paper is 3" wide fan-folded tape (560A, 561B, 562A and 565A also use roll paper) and is easily changed; (4) holdoff signals from the recorders (except 565A) prevent external equipment from changing input data while print wheels are being positioned, and a print command pulse is required from the data source to initiate a recorder print cycle; (5) standby, momentary and print-on-command operation is manually selectable; (6) the recorders are designed for continuous unattended operation; the printing mechanisms are designed for simplicity, durability, and trouble-free operation with little maintenance required.

An analog output, suitable for driving either potentiometer or galvanometer recorders is standard on the 560A and optional for those 562A's with either 1-2-2-4 or 1-2-4-8 BCD column boards installed. Analog output is very useful for continuous analog plots of data variations such as oscillator drift where the important information is in the printed record's last few digits. HP can also supply separate digital-to-analog converters (Models 580A and 581A, page 98).

### 20 line/sec Model 5050A

This recorder accepts up to 20 columns of 4-line BCD data from 1 or 2 sources, and prints up to 18 of these columns at rates up to 20 lines per second. It is not necessary for all input data to be in the same BCD code; contact Hewlett-Packard for details of mixed-code operation.

The 5050A can easily be set up so that zeroes that are not significant are not printed.

### 5 line/sec printers

(Models 562A, 560A, 561B and 565A)

These printers record up to 11 columns of data (12 on special order) and all utilize the same basic printing mechanism. Model choice is usually based upon the flexibility required, input codes, and the cost of equipping the instrument to operate with the printer. A wide variety of special print wheels is available.

### Model 562A

This printer requires a parallel-entry, 4-line, binary-coded-decimal input (or 10-line decimal; see options on page 96). The 562A (utilizing plug-in column board input circuitry) is extremely flexible, allowing operation from two unsynchronized sources. Interchangeability of column boards allows complete mixing of the available codes among the columns. A unique storage feature in the 562A permits the driving source to transfer BCD data into the 562A binaries in 2 milliseconds, thus freeing the source to initiate a new measurement.

### Model 560A

The Model 560A accepts "single-line" or staircase information for each column (digit position) from the data source, i.e., each position (0 through 9, blank and —) of each print wheel is determined by a specific voltage level on a single-line connection to that column. For the 560A, digital recorder adapter kits for field installation in HP counters are available as follows:

HP Counter model	Kit number	Price
521 Series	521D-95A	\$45
522B	522B-95A	\$45
523B	523B-95A	\$45
523C,D	523D-95A	\$45
524B	524B-95C	\$200
524C,D	524D-95A	\$60

HP 405A-95C Adapter, connects 560A to 405CR Digital Voltmeter, \$85.

### Model 561B

The 561B requires a "10-line" input for each column of information from the data source; thus, each print wheel position is controlled by a separate line.

Digital recorder kits for field installation in HP counters are available to permit operation with the 561A: for 521D and 521E counters, kit 521D-95B, \$45; for 523C, kit 523C-95B, \$65; for 524C, kit 524C-95B, \$165.

### Model 565A

The HP Model 565A is the basic printer mechanism used in the 562A, 561B and 560A digital recorders. Data entry is parallel, and one line is needed for each position on each print wheel. Control cables and driving electronics must be fabricated for each 565A application. Front panel appearance of the 565A is similar to the right-hand half of the 561B, and it is 9 $\frac{3}{4}$ " deep behind the front panel.

### Digital clocks

For providing time-of-day reference to recorded data, all HP recorders (except the 565A) may have a digital clock installed. The HP Model 570A Digital Clock is used with the 560A Digital Recorder, the 571B Digital Clock with the 561B Digital Recorder, and a special clock, the H03-571B, is used with the 562A Digital Recorder. These clocks indicate time to 23 hours, 59 minutes and 59 seconds in an in-line display. All time digits are available for printing. The location and number of time digits on the printed record are determined by connector arrangements on the rear of the digital recorders. Clocks also issue timing signals.

### Data plotting systems

Data plotting instrumentation systems produce graphical plots from digital information stored in punched cards, perforated tape or magnetic tape as produced by a 2010 Series or similar data acquisition system. The 2031 (page 94) accepts data directly from magnetic or perforated tape, or operates from a punched card reader. Data also can be entered manually on a keyboard.

When digital data is more meaningful in graphical form a tape editor, 2734B (page 94) is available to provide direct x-y graphical output of data recorded on magnetic or punched paper tape. With any of the data acquisition systems, you can measure—then play back immediately on a 2031 plotting system. No computer or other equipment or intermediate steps are required.



# RECORDERS



## DIGITAL PLOTTING SYSTEMS

X-Y displays of digital information  
2031 Series

The Dymec 2031 Digital Data Plotting Systems provide easily read graphical presentations of digital data stored on punched card, paper tape or magnetic tape. A 2031 System is a valuable accessory to any computer installation, for both quick visual checks of the computer data and the production of accurate finished curves. Systems may also be used to plot data recorded on perforated tape or magnetic tape by a Dymec 2010, 2013, 2015, or 2017 Series Data Acquisition System. This allows measurements to be examined immediately after acquisition without waiting for computer analysis.

Three basic systems are available, as outlined in the table. The punched card and tape systems can accept the complementary input simply by addition of the appropriate input device.

The heart of the 2031 Systems is the 2701A Point-Plot X-Y Translator or 2702A for line plots. These units convert digital information to analog voltages, and include control circuits to initiate card or tape readout and actuate the functions of the x-y recorder. Instruments are all solid state and feature modular plug-in construction.

	2031A	2031C	2031E
Type of input	punched cards	perforated tape	magnetic tape
Plotting area	10" x 15" on 11" x 17" paper; optional roll chart.		
Price	\$9,490	\$8,500	\$15,670
Options	Tape editor (2031C, E), line generation, cabinet		

Standard 2031 Systems plot data as a series of discrete points. The plotter is equipped with a character printer for plotting each point; up to six characters may be selected manually. Line plotting is optionally available, allowing the system to interpolate automatically from coordinate data supplied for successive points, and draw smooth straight lines to connect the points. Lines are drawn at high speed with minimum overshoot. The line segment generator employs digital techniques which contribute no degradation to system accuracy. No adjustments for line length and circuit balancing are required.

Data acquired by Dymec 2010, 2013, 2015 or 2017 Series Data Acquisition Systems with punched tape or magnetic tape output can be plotted directly on a 2031 Plotting System. To select the desired information from the data tape, a 2734B Tape Editor is added to the plotting system. The editor offers these plotting modes: (1) data in any two channels can be plotted against each other in x-y form; (2) data in any channel can be plotted against time-of-day recorded on the tape.

The 2031E Plotting System includes a digital magnetic tape reader and is used to plot data from these tapes. Dymec data acquisition systems are available with computer-compatible punched tape or card or digital magnetic tape output. Computer plotting sub-routines also can be furnished to allow tapes to be prepared by most IBM computers for plotting by a 2031E,F System. With suitably prepared tapes, a tape editor is not required.

A serial-entry keyboard is supplied with each system for manual plotting of tabular data and for calibrating the x-y plotter. The keyboard is integral with the 10" x 15" plotters.

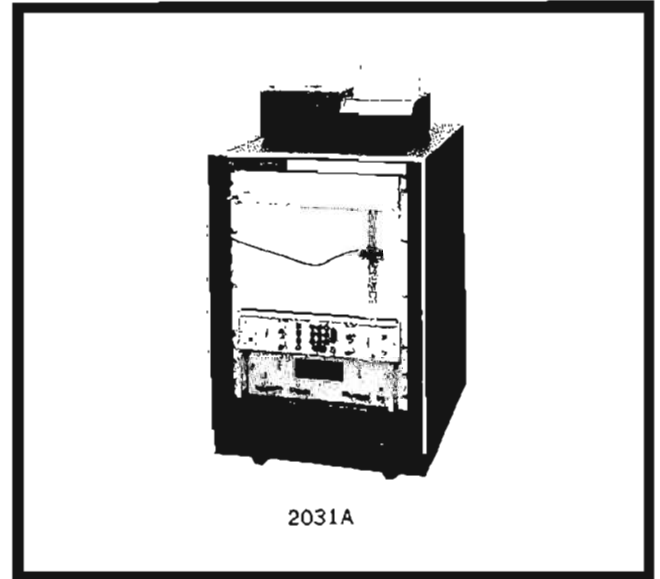

2031A

### Specifications

**Punched card input (2031A):** DY-2736A Card Reader reads 80-column punched cards in any format.

**Punched tape input (2031C):** code: IBM 8-level; system can be modified to accept any code in 5- through 8-level at extra cost; tape size: 1" standard; front-panel control allows tape reader to handle 7/8" or 11/16" tape for non-standard codes.

**Magnetic tape input (2031E):** recording standards: IBM compatible; tape width: 1/2"; reel: 10 1/2" diameter, IBM type; code: IBM BCD; format: as prepared by Dymec data acquisition system or standard computer subroutines.

**Keyboard input (all systems):** manual keyboard for entering 4 digit coordinates into x and y axes; key for sign included.

**Resolution:** 4 digits (10,000 counts), sign accepted for both axes.

**Accuracy:** overall system accuracy better than  $\pm 0.15\%$  f.s.; repeatability better than  $\pm 0.05\%$  f.s.

**Point plotting speed:** punched cards: 50 pts./minute max.; perforated and magnetic tape: 120 pts./minute max. (1/8" spacing).

**Line plotting speed (option):** lines between points are drawn at 4 inches per second; speed automatically reduced to 2 inches per second as point is approached, minimizing overshoot.

**Digit selection:** any 4 consecutive digits from up to 11, supplied for each coordinate.

**Scale factor:** continuous adjustment up to X20 for each axis (full scale may be varied from  $\pm 9999$  to 1000 counts).

**Zero shift:** continuously-adjustable offset up to two full scale lengths for each axis.

**Zero suppression:** switch-selected 2000-count increments.

**Operating conditions:** specifications apply for ambient operating temperatures from +10 to +50°C; relative humidity up to 95% at 40°C; full accuracy after 30-second warm-up.

**Power:** 115 V  $\pm 10\%$ , 60 Hz, 250 W maximum.

**Optional modifications:** (prices on request) sequential character selection: D-2 Character Printer; automatic character selection: 2733A Character Printer and programming modification to x-y translator and recorder; automatic paper advance: includes automatic drive circuitry, for 10" x 15" recorder (bench mount) only; card input: can be added to 2031C tape input systems to allow operation with punched card input; tape reader-spooler to 2031C; rack mount recorder: 10" x 15", no additional charge; line plotting, 2702A X-Y Translator; tape editor: 2734B, can be added to 2031C,E Systems; no change to system required.



# DIGITAL RECORDER

Rapid printing rates; mixed code operation  
Model 5050A



## RECORDERS

### Advantages:

- Prints at 20 lines/sec.
- 18 column capacity
- Input code versatility
- Few moving parts
- Quiet operation

This latest HP Digital Recorder (available Spring 1967) has been designed to be fully compatible with existing HP solid state equipment. A significant advance has been made in print capacity and rate; this recorder will accept up to 20 columns of 4 line BCD data from one or two sources, and prints up to 18 of these columns at rates up to 20 lines per second.

The 5050A permits mixed code operation in that it is not necessary that all input data be in the same BCD code. Contact HP for further details. A further feature allows the recorder to be set up so that zeros that are not significant are not printed.

The print drum (18 print wheels with 16 printing positions each) rotates continuously, eliminating the stop-start operation of slower printers; an inked roller presses against the drum, constantly renewing the ink on the drum characters (pressure sensitive paper operation is optional). The print cycle begins with a print command from the data source, a BCD code for each print position of the drum being compared with the BCD signal from the data source. In any column where the two agree, the print hammer is momentarily activated, pressing the paper against the character. Asynchronous printing is hence a feature of this machine.

The reduction in moving parts resulting from this system leads to ultra reliable operation and easy maintenance. Particular attention has been paid to ensuring that noise is as low as possible.

The data source is inhibited through the print cycle.

### Tentative Specifications

**Accuracy:** identical to input device used.

**Printing rate:** 20 lines per second, maximum.

**Column capacity:** to 18 columns.

**Print wheels:** 16 positions, numerals 0 through 9, —, +, A, V, Ω, \*; other symbols available.

#### Input requirements

**Data input:** parallel entry, BCD (1-2-2-4, 1-2-4-8 or 1-2-4-2) "1" state must differ from "0" state by at least 4.5 volts but by no more than 75 volts.

**Reference voltages:** BCD codes require both "0" and "1" state references; reference voltages may not exceed  $\pm 150$  V to chassis; input impedance is approximately 1 megohm.

**Hold-off signals:** both polarities are available simultaneously for BCD codes and are diode-coupled; 10 mA maximum load + 15 V open circuit from 1 K source, —15 V open circuit from 1 kΩ source.

**Print command:** + or — pulse, 6 to 20 volts amplitude, 1 V/ $\mu$ sec minimum rise time, 20  $\mu$ sec or greater in width, ac coupled.

**Transfer time:** 50 msec.

**Paper required:** HP folded paper tape (18,000 prints per packet with minimum spacing) HP Stock No. 9281-0386 or folded pressure sensitive paper.

**Line spacing:** adjustable, 3.5 to 4.5 lines/inch.

**Inking:** ink roller or pressure sensitive paper.

**Operating temperature:** —20°C to +65°C with pressure sensitive paper, +10°C to 40°C with ink roll.

**Power:** 115 or 230 V  $\pm 10\%$ , 50 to 60 Hz, approx. 100 W idle, 190 W at 20 lines/sec. 50 Hz model with 20 prints/sec available.

**Dimensions:** cabinet: 16 $\frac{3}{4}$ " wide, 8 $\frac{1}{2}$ " high, 18 $\frac{3}{8}$ " deep (426 x 226 x 467 mm).

**Weight:** net 40 lbs (18 kg).

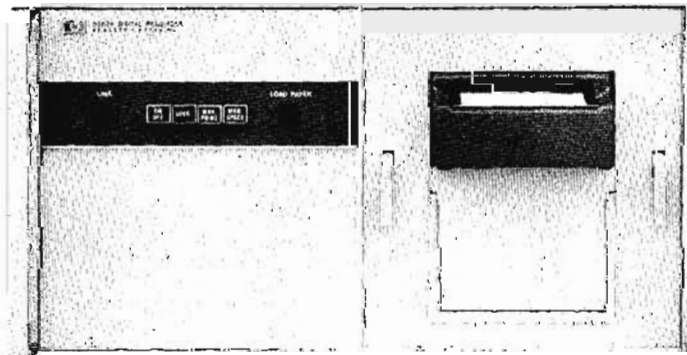



## DIGITAL RECORDER

Flexible data input with information storage  
Model 562A

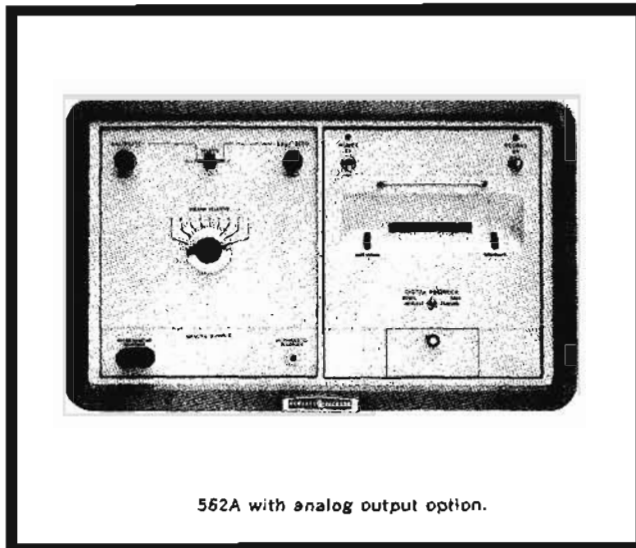

562A with analog output option.

HP Model 562A Digital Recorder is a solid-state electro-mechanical device providing a printed record of digital data from any of a number of sources. Parallel data entry and low-inertia moving parts allow printing rates as high as 5 lines per second, each line containing up to 11 digits. Twelve-digit capacity is available on special order.

Data enter the unit through rear-mounted 50-pin connectors. Internal plug-in connectors route the information to any desired sequence of print wheels. A separate storage binary unit is associated with each individual print wheel for 4-line BCD input codes.

Model 562A may be equipped to translate 1-2-2-4 BCD, other 4-line codes or 10-line code by substituting plug-in column boards and input connector and cable assemblies.

### Specifications

**Accuracy:** identical to input device used.

**Printing rate:** 5 lines per second, maximum.

**Column capacity:** to 11 columns (12 available on special order).

**Print wheels:** 12 positions, numerals 0 through 9, a minus sign and a blank; other symbols available.

#### Input requirements

**Data Input:** parallel entry, BCD (1-2-2-4, 1-2-4-8 or 1-2-4-2) or 10-line, see Options; "1" state must differ from "0" state by at least 4 volts but by no more than 75 volts.

**Reference voltages:** BCD codes require both "0" and "1" state references; 10-line codes require reference voltage for "0" state; reference voltages may not exceed  $\pm 150$  V to chassis; input impedance is approximately 270 K ohms.

**Hold-off signals:** both polarities are available simultaneously for BCD codes and are diode-coupled; 10 mA maximum load +15 V open circuit from 1 K source, -5 V open circuit from 2.2 K source (160 msec hold-off is provided for 10-line codes).

**Print command:** + or - pulse, 6 to 20 volts amplitude, 1 V/ $\mu$ sec minimum rise time, 20  $\mu$ sec or greater in width, ac coupled.

**Analog output (optional):** (from 1-2-2-4 or 1-2-4-8 boards) accuracy is  $\pm 0.5\%$  of full scale or better; 100 mV for potentiometer recorder; 50 K ohm minimum load resistance; 1 mA into 1.5 K ohm maximum for galvanometer recorder.

**Transfer time:** 2 msec for BCD codes.

**Paper required:** HP folded paper tape (15,000 prints per packet with single spacing) HP Stock No. 560A-131A or standard 3-inch roll tape.

**Line spacing:** single or double.

**Power:** 115 or 230 V  $\pm 10\%$ , 50 to 60 Hz, approx. 130 W. (4 prints/sec at 50 Hz; 50 Hz model with 5 prints/sec available.)

**Dimensions:** cabinet: 20 $\frac{3}{4}$ " wide, 12 $\frac{1}{2}$ " high, 18 $\frac{1}{2}$ " deep (527 x 318 x 470 mm); rack mount: 19" wide, 10-15 $\frac{3}{32}$ " high, 16 $\frac{1}{2}$ " deep (483 x 266 x 419 mm).

**Weight:** net 35 lbs (16 kg), shipping 80 lbs (36 kg) (cabinet); net 30 lbs (13 kg), shipping 63 lbs (31 kg) (rack mount).

**Price:** HP 562A, \$1085 (cabinet); HP 562AR, \$1060 (rack mount); basic unit with 11-column capacity; column boards, input connector assemblies and cables required for operation are not included, see Options.

#### Options, Group 1

(Completely equips 562A for operation with Hewlett-Packard and Dymec instruments.)

Option 11. For 6-column operation from 1-2-2-4 "1" state positive code, add \$540

Option 12. For 9-column operation from 1-2-2-4 "1" state positive code, add \$765.

Option 13. For 11-column operation from 1-2-2-4 "1" state positive code, add \$993.

Option 14. For operation with 5245L; 10-column operation; prints measurement unit and indicates decimal position — e.g., 16942.496 kHz would be printed as 3 kHz 16942496; the first digit shows how far to move the decimal to the left; add \$865.

#### Options, Group 2, column boards

Option 21. 1-2-2-4 "1" state positive, \$75 each.

Option 22. 1-2-4-8 "1" state positive, \$75 each.

Option 23. 1-2-4-8 "1" state negative, \$75 each.

Option 24. 1-2-2-4 "1" state negative, \$75 each.

Option 25. 10-line "1" state positive (no storage), \$50 each.

Option 26. 10-line "1" state negative (no storage), \$50 each.

Option 27. 1-2-4-2 "1" state negative, \$75 each.

**NOTE:** Input connector assemblies and input cables (Group 3 options) are required for use with Group 2 column boards.

#### Options, Group 3, connector assemblies

Option 30. BCD input connector assembly for up to 9 columns, \$55.

Option 31. BCD input connector assembly for up to 6 columns, \$43.

Option 32. Input cable, for up to 10 BCD columns or three 10-line columns, \$35.

Option 33. 10-line input connector assembly for up to 3 columns, \$35.

Option 34. BCD input connector assembly for up to 10 columns, \$60.

**NOTE:** More than one input connector assembly and input cable are required for: 1. more than nine BCD columns; 2. operation from two sources; 3. more than three 10-line columns.

#### Options, Group 4

Option 41. Analog output (from 1-2-2-4 boards), \$175.

Option 42. Analog output (from 1-2-4-8 boards), \$175.

## DIGITAL RECORDERS

Print 10-line or staircase data, 5 lines/sec  
Models 560A, 561B, 565A



## RECORDERS

Similar in operation to the HP 562A, the 560A accepts only parallel entry staircase inputs, and the HP 561B accepts only 10-line decimal code inputs. The 560A also supplies an output (0-100 mV, 0-1 mA) for analog recordings of any 3 adjacent digits. The HP 565A Printer Mechanism is mechanically similar to the mechanism in the 560A, 561B and 562A, and is useful in custom systems.

### Specifications, 560A, 561B

- Column capacity:** 11 columns (12 available on special order).
- Print rate:** 5 lines per second.
- Print wheels:** 12 positions having numerals 0 through 9, a minus sign, and a blank; other symbols are available on special order.
- Input:** 560A: parallel entry staircase voltages, staircase descends from +135 V at count of zero to +55 V at count of nine; 561B: decimal code, 10 lines, plus 2 lines for blank and minus sign for each column.
- Driving sources:** 560A: HP electronic counters which have staircase output recorder kits installed, 405A-95C Adapter, or other sources providing appropriate input voltages; 561B: HP electronic counters (521D, 521E, 523C, 524C; pages 522 to 526) with recorder kits, 405CR Digital Voltmeter, stepping switches, relays, beam switching tubes, contact closures, or -15 to -100 volts connected to appropriate input wire.
- Print command signal:**  $\pm 15$  volts peak, 10  $\mu$ sec or greater in width, 1 V/ $\mu$ sec minimum slope; manual control with momentary-contact switch.
- Line spacing:** zero, single or double; in "zero" does not print, paper does not advance.
- Paper required:** 560A-131A folded paper tape or standard 3" roll; tape sufficient for 15,000 single-spaced lines.
- Power:** 115 or 230 volts  $\pm 10\%$  approximately 75 watts. (250 watts for 560A) 50 to 60 Hz (4 prints/sec maximum at 50 Hz); 50 Hz model available which retains 5 print/sec capability.
- Dimensions:** cabinet: 20 $\frac{3}{4}$ " wide, 12 $\frac{3}{4}$ " high, 18 $\frac{1}{2}$ " deep (527 x 324 x 470 mm); rack mount: 19" wide, 10-15/32" high, 16 $\frac{1}{2}$ " deep (483 x 266 x 419 mm).
- Weight:** 560A: net 63 lbs (28.5 kg), shipping 81 lbs (36.8 kg) (cabinet); net 55 lbs (25 kg), shipping 78 lbs (35.5 kg) (rack mount). 561B: net 35 lbs (19.7 kg), shipping 70 lbs (31.5 kg) (cabinet); net 30 lbs (18 kg), shipping 65 lbs (29.2 kg) (rack mount).
- Accessories available:** 560A-131A folded paper tape, 24-packet carton, \$20; 560A: 9283-0602 inked ribbon, \$3.50, 560A-16P

Extension Cable, 6 ft. (1830 mm) long, 20-conductor, \$65, 560A-16Q Extension Cable, 6 ft. (1830 mm) long, 26-conductor, \$85; 561B: 561B-16A Cable, 6 ft., 6 columns, \$100, 561B-95D Connectors (mates with J101 or J102). \$8.50.

**Accessories furnished:** 560A and 561B: 9281-0018 folded paper tape, one packet, 9283-0002 inked ribbon, 560A-95N Digital Recorder Service Kit; 560A: 560A-16H Cable, accommodates 8 columns, connects to Option 01-equipped HP vacuum tube counters and 405CR Digital Voltmeter; 561B: 561B-16A Cable, accommodates 6 columns, connects to Option 02-equipped vacuum tube counters.

**Price:** HP 560A, \$1400 (cabinet); HP 560AR, \$1385 (rack mount); additional 560A-58 Plug-in Comparators (one required per column; 6 furnished), \$125 each; HP 561B, \$1150 (cabinet); HP 561BR, \$1135 (rack mount).

### Specifications, 565A

- Number of columns:** 11 (12 available on special order).
- Data entry:** parallel entry to all columns; one line required for each position of each print wheel to be operated.
- Maximum print rate:** 5 lines per second.
- Standard characters:** 0 through 9, minus sign and blank (others available on special order); dimensions: approximately 0.085" wide, 0.1" high.
- Column spacing:**  $\frac{1}{4}$ ".
- Line spacing:** 5/32" single space; 5/16" double space.
- Power**
- Motor: 115 V  $\pm 10\%$ , 60 W, 50 to 60 Hz (50 Hz provides 4 prints/sec max.).
- Clutch solenoid: 240 to 260 Vdc, 75 mA (operates for approx. 15 msec to start printing cycle); coil designed for vacuum tube switching networks; lower voltage coils are recommended and available on special order for transistor switching.
- Pawl magnets: 60 to 70 Vdc, 15 mA (operate when needed during printing cycle); coils designed for vacuum tube switching networks; lower voltage coils are recommended and available on special order for transistor switching.
- Dimensions:** 9 $\frac{3}{4}$ " high, 8 $\frac{3}{8}$ " wide, 9 $\frac{3}{4}$ " deep (248 x 213 x 248 mm). Appearance similar to right-hand half of 561B.
- Weight:** net 15 lbs (7 kg); shipping 20 lbs (9 kg).
- Price:** HP 565A (with high-voltage clutch and pawl coils for vacuum tube drive), \$750; for 115 V, 50 Hz operation with 5 prints/sec capability specify H27-565A, \$763; for 230 V, 50 Hz operation with 5 prints/sec capability specify H24-565A, \$765.

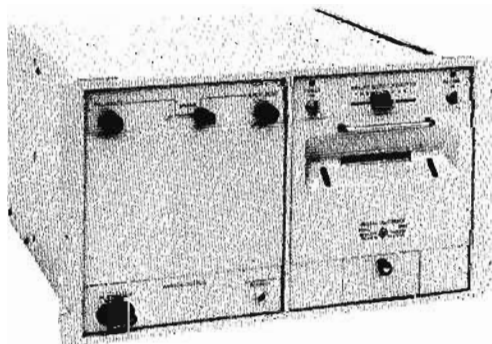

560AR

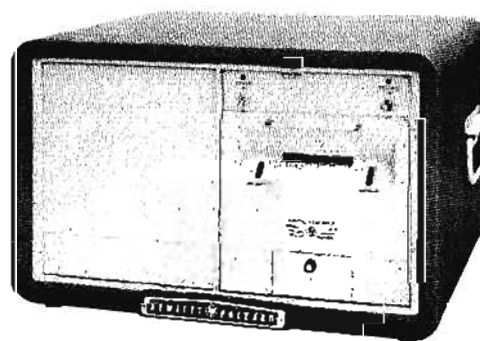

561B

# RECORDERS



## D/A CONVERTERS; DIGITAL CLOCKS

High resolution recording; time recording

Models 580A, 581A; 570A, 571B

Digital-to-Analog Converters make possible automatic, high-precision analog records from electronic counters, digital voltmeters and other devices providing the proper 4-line BCD output code. These converters operate directly with HP Quartz Thermometers, HP Nuclear Scalers and most HP solid-state counters; output kits are available for HP vacuum tube counters. Since the digital-to-analog converters tolerate a wide range of input voltages, they are suitable for use with other tube and solid-state devices.

Output signals for strip-chart or x-y recorders of both the potentiometer and galvanometer types are available, and controls for recorder calibration and zero adjustment are provided. A 50-pin connector accepts 4-line data from a maximum of nine decade counting units. This information is transferred to storage binary units upon receipt of a command pulse from the counting source. The stored data are then translated and weighted to provide the proper analog output voltage or current.

### Specifications, 580A, 581A

**Accuracy:** 0.5% of full scale or better.

**Potentiometer output:** 100 mV full scale; minimum load resis-

tance 20 K; calibrate control; dual banana plugs front and rear; typical 5 mV residual output at "000".

**Galvanometer output:** 1 mA full scale into 1500 ohms; zero and calibrate controls; phone jack front and rear.

**Driving source:** parallel entry 4-line BCD, 1-2-2-4 (9 digits maximum); "1" state +4 to +75 volts with reference to "0" state.

**Reference voltages:** reference voltages required for both the "0" and "1" state, reference voltages not to exceed  $\pm 150$  V to chassis.

**Command pulse:** positive or negative pulse, 20  $\mu$ sec or greater in width, 6 to 20 volts amplitude

**Transfer time:** 1 millisecond.

**Power:** 115 or 230 volts  $\pm 10\%$ , 50 to 1000 Hz, 11 watts.

**Dimensions:** 580A (rack mount): 16 $\frac{3}{4}$ " wide, 3-15/32" high, 11 $\frac{1}{4}$ " deep (425 x 88 x 286 mm); 581A: 7-25/32" wide, 6-3/32" high, 8" deep (198 x 155 x 203 mm).

**Weight:** 580A: net 13 lbs (6 kg), shipping 16 lbs (7.2 kg); 581A: net 8 lbs (3.5 kg), shipping 13 lbs (6 kg).

**Accessory furnished:** 562A-16C Cable, 6' (1830 mm) long with an Amphenol 57-30500 connector at each end.

**Price:** HP 580A, \$525; HP 581A, \$525.

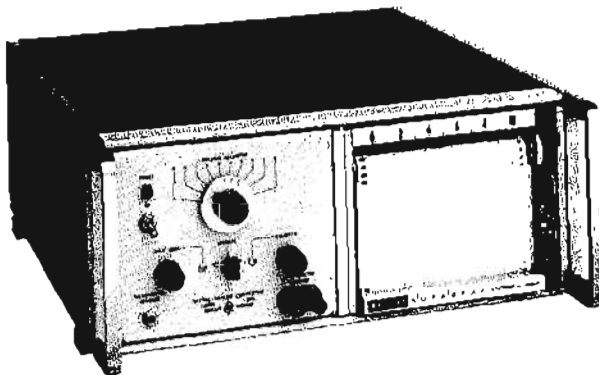

581A, Moseley 680 Recorder

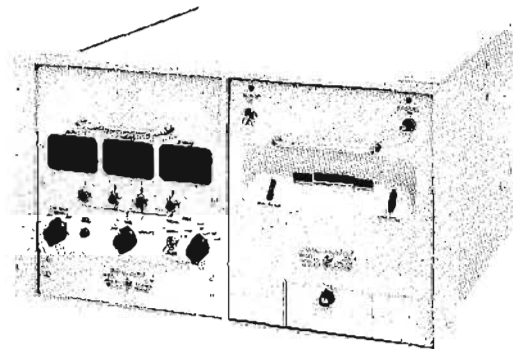

571B with 561BR Recorder

The 570A, 571B Digital Clocks, which mount in the left side of the HP 560A and 561B Digital Recorders (page 97), provide time-of-day information and control the rates at which measurements are made. They indicate time in hours, minutes and seconds (24-hour basis) in an in-line display. All time digits displayed are available for printing. Clocks may be ordered installed in the respective recorders. In addition, a modified 571B (H03-571B) is available for use with the HP 562A Digital Recorder (page 96).

### Specifications, 570A, 571B

**Indication:** 6-in-line digital display tubes indicate to 23 hours, 50 min, 59 sec; 12-hour format available on special order.

**Time base:** front-panel time-base switch selects: (1) 60 Hz (50 Hz available on special order), (2) counter (1 pps, HP vac. tube counters), (3) external (5 V positive pulses, 200  $\mu$ sec long, 1 pps; input impedance approximately 500 ohms).

### Time print format

**570A:** time format determined by wiring of program plug at rear of 560A (serves all 11 cols.), normally prints six time digits on left side of paper; blank also programmable in any single column.

**571B:** six time digits recorded in right-hand columns of 561B with clock connected to J101 on 561B; with clock connected to J102, time records in the five left-hand columns without tens-of-hours.

**562A:** recording format (all columns) is set-up by plug-in connectors and column boards in 562A.

**Weight:** net 20 lbs (9 kg); shipping 28 lbs (13 kg).

**Power:** ac and dc supplied by digital recorder, approximately 15 watts (normally wired to operate on 60 Hz).

**Price:** HP 570A, \$1050; HP 571B, \$1000.

Because of many options for the 570A and 571B, please contact your nearest HP sales office when ordering.

## X-Y RECORDERS



## RECORDERS

The Cartesian coordinate graph is one of the most efficient means ever devised to portray related data clearly. Modern x-y recorder speed data interpretation by producing such graphs quickly. An x-y recorder automatically and conveniently plots the value of an independent variable versus a dependent variable, directly on conventional graph paper, working from readily derived electrical signals.

Many years of experience by the Hewlett-Packard Moseley Division in pioneering and manufacturing x-y recorders has provided features which make Moseley Division recorders the most useful of their kind. Among advanced features are:

- Autogrip® electric paper hold-down, with no moving parts
- inputs with 1-megohm null loading
- calibrated multi-scale ranges
- dc sensitivity to 100  $\mu\text{V}/\text{inch}$
- ac sensitivity to 5  $\text{mV}/\text{inch}$
- zero offset up to 4 scale lengths
- 140 dB dc common mode rejection
- 120 dB ac common mode rejection

### Basic operation of x-y recorders

The x-y recorder uses electrical servo systems to produce a pair of crossed motions, moving a pen so as to write precise x-y plots. It consists of basic balancing circuits, plus auxiliary elements to make the instrument versatile.

A self-balancing potentiometer circuit compares an unknown external voltage with a stable internal reference voltage. The difference between these voltages is amplified and applied to a servo motor to drive a potentiometer in a direction that will null any difference or error voltage. Accuracy of plots made by this principle is typically 0.1%. The full-scale range of the recorder for each axis is obtained with input signals as low as fractions of a millivolt. Thus, the output of many low-level devices, such as thermocouples and strain gages, may be plotted directly without additional amplification.

A stepped attenuator or range selector is included for each axis, so voltages as high as 500 volts may be handled directly. Input resistance is at least 200,000 ohms per volt, with higher values, including constant 1-megohm input resistance, available on some models. Sensitivity may be as high as 100  $\mu\text{V}$  per inch for dc, 5  $\text{mV}$  per inch for ac.

Zeroing potentiometers permit the user to locate the plotting origin as desired

by inserting an offset voltage. With these controls the zero of either axis, or both, can be extended or suppressed up to four full-scale lengths on some models, so plotting may be carried out in any desired quadrant.

To fit the range of the recorder's response exactly to the coordinates of the paper in use, or to the units of measurement desired, a continuously adjustable range control may be switched in as a substitute for the calibrated control. Thus, the response range of the recorder can be adjusted smoothly to match, for example, some calibrated maximum from a transducer, so the paper's coordinates directly correspond to the desired units of measurement (psi, °C, etc.).

Since it is often desirable to plot a function against time, a time base sweep circuit is supplied or made available as an accessory. (Model 17108A)

### Accessories and options

The range of accessories offered for Hewlett-Packard Moseley Division recorders exceeds that offered by any other manufacturer. When equipped with a curve follower, an x-y recorder can read a previously recorded graph, feeding out a pair of analog signals. Roll chart accessories provide capability for manual or automatic continuous chart advance or frame advance plus convenient chart storage. Single character or multi-character automatic printers for point plotting are offered for use with 11"x17" recorders. Logarithmic converters, waveform translators to enable plotting of oscilloscope traces, keyboard control for plotting of tabular data in print graph form, and a self contained external time base are also available.

Options include rack mounting, metric calibration and scaling, special input characteristics, rear connections and others. The range of accessories is constantly being augmented. The user may be sure his Hewlett-Packard x-y recorder will be adaptable to the widest possible variety of future needs, without added initial cost.

### Selecting an x-y recorder

Moseley Division x-y recorders may be selected among models in two basic chart sizes, 8½"x11" or 11"x17". Three basic levels of performance are available depending upon measurement needs. For general purpose applications where high dynamic performance is not required the newly designed inexpensive recorders (Models 7035A, 7005A) represent an extremely good value in x-y recorders.

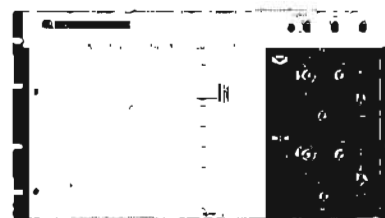

7035A X-Y Recorder

Two pen models are available, capable of simultaneously plotting two curves. Certain models have high sensitivity, high common mode rejection and high input resistance. Models are available with and without ac and time sweep capability. Metric models are available with scaling and calibration equivalent to that shown below but in metric units.

Hewlett-Packard X-Y Recorders

Model	Chart size	Performance level	Pens	Sensitivity $\text{mV}/\text{inch}$	Input resistance (maximum sensitivity)	AC	Time sweep	Rack model	Price
7035A	8½ x 11	general purpose	1	1 10	Potentiometric 100 k	no	internal—no external—yes (Model 17108A)	same	\$895
135	8½ x 11	medium	1	0.5	*200 k/volt	no	yes	same	1650
135A	8½ x 11	medium	1	0.5	*1 meg	no	yes	same	1650
136A	8½ x 11	medium	2	0.5	*1 meg	no	yes	same	2650
7030A	8½ x 11	high	1	0.1	*1 meg	no	yes	same	1795
7005A	11 x 17	general purpose	1	1 10	Potentiometric 100 k	no	internal—no external—yes (Model 17108A)	same	1195
2D-2	11 x 17	medium	1	0.5	*200 k/volt	no	yes	2DR-2	1950
2D-2A	11 x 17	medium	1	0.5	*1 meg	no	yes	2DR-2A	1950
2FA	11 x 17	medium	2	0.5	*1 meg	no	yes	2FRA	3375
7000A	11 x 17	high	1	0.1 dc 5 ac	*1 meg	yes	yes	7000AR	2495
7001A	11 x 17	high	1	0.1 dc	*1 meg	no	yes	7001AR	2175

\*Potentiometric input possible on most sensitive ranges by removing straps on input board.

# RECORDERS



## 8½ x 11 X-Y RECORDER

Low Cost — multiple use

Model 7035A



The Moseley Model 7035A is a high performance, low cost, solid state X-Y Recorder for general purpose applications not requiring high dynamic performance. Each axis has an independent servo system with no interaction between channels. The recorder will draw a graph of two related functions from two dc signals representing each of these functions. The ultra-compact design is convertible to rack mounting with only the addition of two wing brackets which are supplied with the model. Also available is a metrically scaled model (7035AM).

The input terminals accept either open wires or plug-type connectors. Five calibrated ranges from 1 millivolt/inch to 10 volts/inch are available in each axis. A variable range control allows any voltage, within the recorder limits, to be adjusted for full scale deflection. Standard features include high input impedance of one megohm (all but the first two ranges), floating and guarded input, 0.2% accuracy, Autogrip electric paper holddown, electric pen lift, and adjustable zero set.

Extra cost options include locks for zero controls and for variable range controls, rear input connector, and retransmitting potentiometer. A plug-in time base (Model 17108A) is also available and operates on either axis to provide five sweep speeds from 0.5 to 50 seconds per inch.

Each closed loop servo system employs a high gain solid-state servo amplifier, Moseley manufactured servo motor, long life balance potentiometer, photochopper, low pass filter, guarded inputs, precision attenuator and balance circuit. Model 7035A is designed for easy maintenance with most components mounted on a printed circuit board and accessible by removing only the rear cover. Both balance potentiometers are accessible for inspection or cleaning by simply removing a trim strip requiring no tools. Also included are snap-on side panels and maintenance free Autogrip paper holddown.

### Specifications

**Input ranges:** 5 fixed calibrated ranges: Standard: 1 mV/in., 10 mV/in., 100 mV/in., 1 V/in., and 10 V/in.; Metric: 0.4 mV/cm, 4 mV/cm, 40 mV/cm, 400 mV/cm, and 4 V/cm, 5 variable ranges: Continuous range adjustment from 1 mV/in. to 25 V/in. (0.4 mV/cm to 10 V/cm) provided by a high resolution control.

**Type of inputs:** floating differential. All input terminals may be placed up to 500 V dc from ground. Critical circuit areas are guarded with guard terminal on front panel.

**Input isolation:** dc—500 megohms (min) to ground at 500 V dc (all terminals). ac—Guard to ground: 0.05 mfd.

**Effective guarded capacity:** 200 pfd (capacity between + and - terminals, and chassis ground with guard shield driven).

Input resistance:

Range	Input resistance
1 mV/in. (.4 mV/cm) variable	Potentiometric (essentially infinite at null) 11k
10 mV/in. (4 mV/cm) variable	100k 100k
100 mV/in. (40 mV/cm) variable	1 meg 1 meg
1 V/in. (400 mV/cm) variable	1 meg 1 meg
10 V/in. (4 V/cm) variable	1 meg 1 meg

**Interference rejection:** conditions for the following data is line frequency with up to 1 k ohm between the negative input and the point where the guard is connected. Maximum ac common mode voltage is 500 volts peak. Maximum dc common mode voltage is 500 volts.

Range		DC(CMR)	AC(CMR)
Standard	Metric		
1 mV/in.	0.4 mV/cm	130 dB	95 dB
10 mV/in.	4 mV/cm	110 dB	75 dB
100 mV/in.	40 mV/cm	90 dB	55 dB
1 V/in.	400 mV/cm	70 dB	35 dB
10 V/in.	4 V/cm	50 dB	15 dB

**Input filter:** 20 dB at 60 Hz; -18 dB/octave above 60 Hz.

**Maximum allowable source impedance:** no restrictions except on fixed 1 mV/in. (.4 mV/cm) range. Up to 20 k ohm source impedance will not alter recorder's performance.

**Accuracy:** ±0.2% at full scale.

**Linearity:** ±0.1% of full scale.

**Dead band:** ±0.1% of full scale.

**Standardization:** continuous electronic zener reference with temperature stability better than 0.002%/°C.

**Zero set:** zero may be placed anywhere on the writing area or electrically set off scale up to one full scale from zero index. Adjustable by a high resolution control.

**Slewing speed:** 15 inches/sec, 37 cm/sec, nominal at 115 V. (Typically 13 inches/sec at 103 V, 16 inches/sec at 127 V.)

**Paper holddown:** Autogrip electric paper holddown grips charts 8½" or 11" or smaller. Writing area: 7" x 10" (18 x 25 cm).

**Pen lift:** electric pen lift capable of being remotely controlled. Connector supplied (#57-30240).

**Dimensions:** 10.15/32" deep, 17½" wide, 5½" high.

**Weight:** approximately 16 lbs (net); shipping 22 lbs.

**Power:** 115 or 230 V ±10%, 50 to 60 Hz, approximately 45 watts.

**Time base accessory:** Model 17108A self-contained external time base has five sweep speeds. Price: \$175.

**Accessories supplied:**

1. Accessory kit: containing slidewire cleaner, slidewire lubricant, set of Bristol wrenches, 2 pens, 1 bottle green ink, 1 bottle red ink, ink filling syringe, remote pen lift mating connector.
2. Appropriate graph paper.
3. Power cord (7').
4. Rack mounting brackets.
5. Flexible plastic dust cover.
6. Instruction manual.

**Price:**

Model 7035A (Standard)	\$895
Model 7035AM (Metric)	\$895

**Options:**

02. Lockable zero and variable controls (both axes)	\$15
03. Retransmitting potentiometer on X axis	
Total resistance: 5 k ±3%	
Linearity (independent): ±0.1%	
Resolution: 0.04%	\$75
05. Rear input connector in parallel with front terminals	\$15

## 8½" x 11" X-Y RECORDER

High-sensitivity to 100  $\mu\text{V}/\text{inch}$   
Model 7030A



# RECORDERS

Assembled on a sturdy aluminum cast frame, the Moseley 7030A X-Y Recorder accepts dc signals with much greater sensitivity and higher common mode rejection than previously possible in one instrument. Guarded and shielded input circuitry has 1-megohm resistance at null on each of 17 ranges from 100  $\mu\text{V}/\text{inch}$  to 20 V/inch, with continuous flexibility of each range for arbitrary full-scale voltages. The 5 most sensitive ranges may be operated in potentiometric mode which draws practically no current at null. The unit has an electronic time sweep with automatic reset or recycle, if desired, at the end of the sweep. The Model 7030A can be used on the bench or rack mounted. A metric model (7030AM) is available with metric scales.

Special multi-contact flat mandrel balancing potentiometers maintain trouble-free operation without frequent cleaning. Zero offset controls for each axis are calibrated in continuously adjustable 5-inch steps which cover 3 full scale lengths on x and 4 full scale lengths on y. Recording accuracy is better than 0.2% of full scale on all ranges, this accuracy being maintained from range to range. Extremely good retrace performance assures high dynamic accuracy and resetability.

The paper holddown system is the exclusive Moseley Autogrip® which operates on an electronic principle, has no moving parts, is quiet, reliable and effective on any paper size up to the capacity of the platen.

### Specifications

**Input ranges:** 17 calibrated ranges: 0.1, 0.2, 0.5, 1, 2, 5, 10, 20, 50 mV/inch, 0.1, 0.2, 0.5, 1, 2, 5, 10, 20 V/inch.

**Metric:** 0.05, 0.1, 0.25, 0.5, 1, 2.5, 5, 10, 25 mV/cm; 0.05, 0.1, 0.25, 0.5, 1, 2.5, 5, 10 V/cm. Plus continuously variable mode.

**Type of inputs:** floating up to 500 V above ground; guarded and shielded.

**Input resistance:** one megohm at null on all calibrated and variable ranges. Potentiometric input on 5 most sensitive ranges by disconnecting an internal buss wire. Potentiometric switch optional.

**Maximum allowable source impedance:** up to 10 k ohm source impedance will not alter recorder's performance on the five most sensitive ranges (0.1, 0.2, 0.5, 1, 2 mV/in.). Higher source impedances will cause an increase in dead zone and a decrease in pen speed. No source impedance restrictions on ranges above 2 mV/in.

**Interference rejection:** dc common mode rejection 140 dB on 2 most sensitive ranges; 120 dB at power line frequency on 2 most sensitive ranges.

**Radio frequency interference:** meets specifications of MIL-I-6181D.

**Slewing speed:** 20 inches/second, maximum, each axis for 60 Hz; 16 inches/second, maximum, for 50 Hz.

**Time sweeps:** may be applied to either axis in 8 calibrated ranges: 0.5, 1, 2, 5, 10, 20, 50, 100 sec/in; Metric models: 0.25, 0.5, 1, 2.5, 5, 10, 25, 50 sec/cm. Adjustable sweep length; may be reset or recycled at any point manually or automatically.

**Accuracy:** 0.2% at full scale; Time sweep: 2% of full scale.

**Linearity:** 0.1% of full scale; Time sweep: 1% of full scale.

**Dead band:** 0.1% of full scale.

**Zero offset:** continuously adjustable with 5" calibrated steps for up to 3 full scale lengths on X and 4 on Y. Zero-check push-button switches on each axis.

**Reference voltage:** continuous electronic reference, zener diode controlled. Temperature stability better than 0.005%/°C.

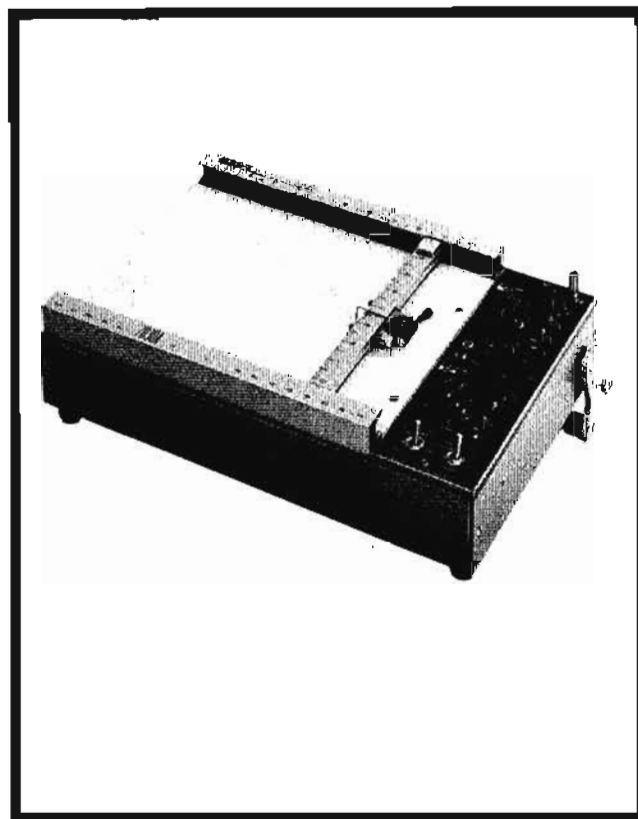

**Writing mechanism:** independent isolated servo mechanism for each axis. Liquid ink pen with visually monitored cartridge.

**Paper holddown:** Autogrip electric paper holddown grip charts 8½" x 11" or smaller; quiet and maintenance free with no moving parts.

**Pen lift:** local and remote pen lift.

**Accessories supplied:**

1. Accessory Kit: Contains spare fuse, slidewire cleaner, slidewire lubricant, set of Bristol wrenches, 2 pens, 12 cartridge-green ink, 12 cartridge-red ink.
2. Appropriate graph paper.
3. Power cord (7').
4. Flexible plastic dust cover.
5. Instruction manual.
6. Rack mounting brackets.
7. Carrying handle.

**Power:** 115 or 230 V, 50 to 60 Hz, 75 volt-amperes.

**Dimensions:** table model: 12-1/16" deep, 4¾" high, 17⅞" long (306 x 120 x 454 mm). Rack model: 4¾" deep, 10-15/32" high, 19" long (120 x 265 x 482 mm).

**Weight:** approximately 20 lbs (9 kg).

**Prices:** Model 7030A (standard)

Model 7030AM (metric)

\$1895

**Options:**

- |  |            |
|--|------------|
| 01 Potentiometric switch for five most sensitive ranges    | add \$ 55  |
| 05 5 k linear retransmitting potentiometer in the X axis   | add \$ 150 |
| 06 Rear input terminals                                    | add \$ 50  |
| 07 3.5 k linear retransmitting potentiometer in the Y axis | add \$ 150 |
| 08 Retransmitting potentiometers in both axes              | add \$ 300 |
| 09 Remote sweep capability                                 | add \$ 75  |



# RECORDERS



## 8½ x 11 X-Y RECORDER

Multi-range, general-purpose plotter  
Model 135 Series

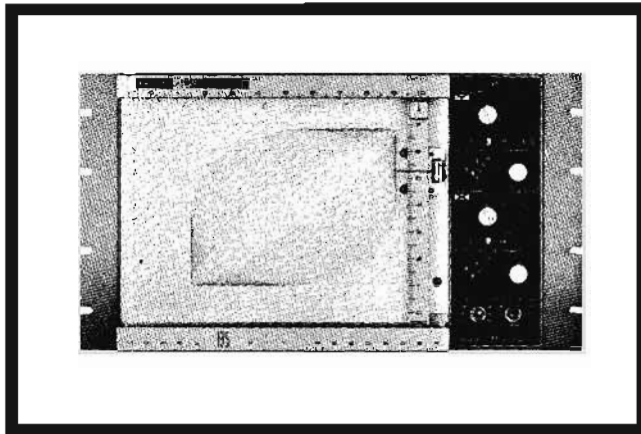

Available in two basic models, these Moseley 8½" x 11" x-y plotters are adaptable to almost any laboratory, field or system application. In the first group, the 135 and the 135M (metric) feature 16 dc input ranges on each axis with a minimum input resistance of 200,000 ohms/volt full scale (10"); in the second group, the 135A and 135AM (metric) feature 11 calibrated ranges with 1-megohm resistance at null.

Unique construction permits instant adaptation to desk or bench positioning in a horizontal, inclined or vertical plane, or rack mounting by the addition of brackets in only 10½" of panel space. A detachable handle doubles as a tilt support or carrying aid. Standard features include advanced transistor circuitry, calibrated time base on the x-axis, zero set and zero suppression, potentiometric input mode, scale factor vernier and autogrip electric paper holddown which has no moving parts, holds any chart 8½" x 11" or smaller, is quiet and maintenance-free.

Modular construction of major assemblies insures maximum flexibility and ease of maintenance. The control module incorporates all input circuitry with conveniently grouped operating controls. A panel group for each axis includes input terminals which accept either open wire or banana plugs, ground terminal, range selector with scale factor vernier, function switch and zero control. High-gain servo amplifiers are plug-in units, isolated and free of ground. Special Moseley servo motors control the ink pen via a pantograph mechanism which is accurate and non-interacting. The pen may be controlled locally or remotely by an electric lift. The "drop-in" pen mounting facilitates easy changing or cleaning. Calibrated scales along each axis align with standard paper markings.

### Specifications

#### Input ranges:

**Model 135:** 16 calibrated ranges: 0.5, 1, 2, 5, 10, 20, 50 mV/inch; 0.1, 0.2, 0.5, 1, 2, 5, 10, 20, 50 V/inch.

**Model 135M:** 16 calibrated ranges: 0.2, 0.5, 1, 2, 5, 10, 20, 50, 100 mV/cm; 0.2, 0.5, 1, 2, 5, 10, 20 V/cm.

**Model 135A:** 11 calibrated ranges: 0.5, 1, 5, 10, 50 mV/inch; 0.1, 0.5, 1, 5, 10, 50 V/inch.

**Model 135AM:** 11 calibrated ranges: 0.2, 0.5, 2, 5, 20, 50 mV/cm; 0.2, 0.5, 2, 5, 20 V/cm.

**All models:** stepless range control permits arbitrary full scale range setting. Potentiometric mode on Y-axis, obtainable on X-axis by removing strap on input circuit board. (Operates on most sensitive range of Model 135; four most sensitive ranges of Model 135A).

**Type of inputs:** floating up to 500 V above ground.

#### Input resistance:

**Model 135:** 200,000 ohms/volt full scale (10") through 1 V/inch range; 2 megohms on all higher ranges.

**Model 135M:** 200,000 ohms/volt full scale (25 cm) through 0.5 V/cm range; 2.5 megohms on all higher ranges.

**Models 135A, 135AM:** one megohm at null on all fixed ranges. When in variable range control mode, 100,000 ohms on four most sensitive range steps and one megohm on all other steps. Potentiometric input draws essentially zero current at null.

**Maximum allowable source impedance:** (Model 135A) up to 10K ohm source impedance will not alter recorder's performance on the four most sensitive ranges (0.5, 1, 5, 10 mV/in). Higher source impedances will cause an increase in dead zone and a decrease in pen speed. No source impedance restrictions on ranges above 10 mV/in. Model 135: up to 1K ohm source impedance will not alter recorder's performance on potentiometric input. Higher source impedances will cause an increase in dead zone and a decrease in pen speed. No source impedance restrictions on any calibrated ranges.

**Radio frequency interference:** meets specifications of MIL-I-6181D.

**Slowing speed:** 20 inches/second, maximum, each axis for 60 Hz; 16 inches/second, maximum, for 50 Hz.

**Time sweeps: (X-axis only)** **Model 135:** 0.5, 1, 2, 5, 10, 20, 50 sec/inch. **Model 135M:** 0.2, 0.5, 1, 2, 5, 10, 20 sec/cm.

**Model 135A:** 0.5, 1, 5, 10, 50 sec/inch. **Model 135AM:** 5 calibrated sweeps: 0.2, 0.5, 2, 5, 20 sec/cm.

**Accuracy:** 0.2% at full scale; Time sweep: 5% of full scale.

**Linearity:** 0.1% of full scale.

**Dead band:** 0.1% of full scale.

**Zero set:** continuously adjustable to any point on the graph paper or up to one full scale, from zero, off the chart paper.

**Reference voltage:** continuous electronic reference, zener diode controlled. Temperature stability better than 0.002%/°C.

**Writing mechanism:** independent isolated servo mechanisms for each axis. Liquid ink pen with ample ink supply. Visually monitored cartridge pens available as option.

**Paper holddown:** AUTOGRIP electric paper holddown grips charts 8½" x 11" or smaller; quiet and maintenance free with no moving parts.

**Pen lift:** local and remote pen lift.

#### Accessories supplied:

- (1.) **Accessory kit:** contains spare fuse, slidewire cleaner, slidewire lubricant, set of Bristol wrenches, 2 pens, 1 bottle of green ink, 1 bottle of red ink, syringe.
- (2.) Appropriate graph paper.
- (3.) Power cord (7').
- (4.) Flexible plastic dust cover.
- (5.) Instruction manuals.
- (6.) Rack mounting brackets.
- (7.) Carrying handle.

**Power:** 115 or 230 V, 50 to 60 Hz, 120 volt-amps.

**Dimensions:** table model: 17¾" wide, 10-15/32" high, 4¾" deep. Rack model: 19" wide, 10-15/32" high, 4½" deep.

**Weight:** approximately 20 lbs (9 kg); shipping 32 lbs.

#### Prices:

Models 135/135M/135A/135AM \$1650

#### Options:

- |    |  |           |
|----|--|-----------|
| 02 | Rear input connectors (with mating connector)  | \$15      |
| 04 | Cartridge ink supply                           | N/C       |
| 05 | 5K ohm retransmitting potentiometer (X-axis)   | add \$100 |
| 06 | 3.5K ohm retransmitting potentiometer (Y-axis) | add \$100 |
| 07 | Retransmitting potentiometer (both axes)       | add \$200 |

## TWO-PEN X-Y RECORDER

Three channels for plotting two curves  
Model 136A Series



# RECORDERS

The Moseley Model 136A is a two-pen three channel ( $x, y_1, y_2$ ),  $8\frac{1}{2}'' \times 11''$  X-Y Recorder, identical electrically and physically to the 135A except for the added second pen with its associated circuitry and controls. The two pens traverse the full vertical axis independently with not less than 0.1 inch horizontal separation, and the horizontal axis simultaneously over the complete recording area of the paper. Input circuitry and controls for each axis are constructed in modular form, electrically isolated and free of ground. Advanced transistor circuitry insures high accuracy and stability. Units are available with metric scales.

The controls for each channel are conveniently grouped with input connectors accepting either banana plugs or open wire. Eleven calibrated steps cover voltage ranges from 0.5 mV/inch to 50 V/inch with continuously variable expansion control for fitting arbitrary voltage limits within the paper margins. One-megohm input resistance at null is a feature of all calibrated ranges. Five time sweeps are provided on the x axis and potentiometric mode on the four most sensitive ranges of both y axes. Potentiometric operation on the x axis is obtainable by removing an internal strap. Zero controls operate without affecting calibration and provide full scale zero set and one full scale of zero suppression.

Reliable paper holddown is provided by Autogrip electric platen, which has no moving parts, is quiet and effective on any size chart  $8\frac{1}{2}'' \times 11''$  or smaller. Pens are capillary fed from a generous reservoir, are "drop-in" mounted, easily changed for color variation or cleaning.

### Specifications

**Input ranges:** 11 calibrated ranges: 0.5, 1, 5, 10, 50 mV/inch; 0.1, 0.5, 1, 5, 10, 50 V/inch. Metric: 0.2, 0.5, 2, 5, 20, 50 mV/cm; 0.2, 0.5, 2, 5, 20 V/cm. Stepless range control permits arbitrary full scale range setting. Potentiometric mode on  $Y_1$  and  $Y_2$  axis, obtainable on X-axis by removing strap on input circuit board operates on four most sensitive ranges of Model 136A.

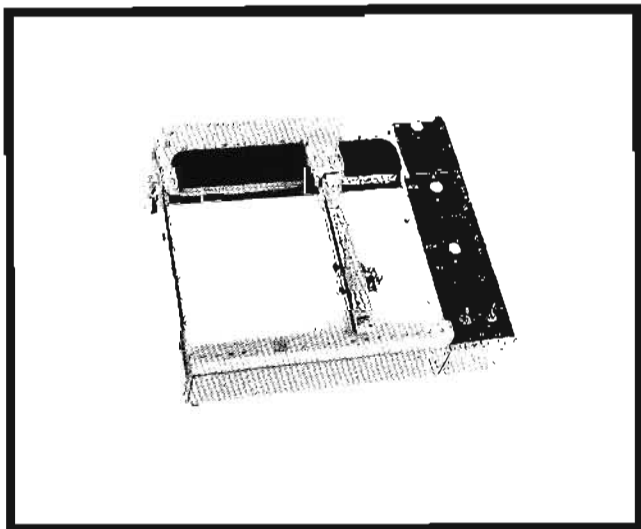

**Types of inputs:** floating up to 500 V dc above ground.

**Input resistance:** one megohm at null on all fixed ranges.

When in variable range control mode, 100,000 ohms on four most sensitive range steps and one megohm on all other steps. Potentiometric input draws essentially zero current at null.

**Maximum allowable source impedance:** up to 10 k ohm source impedance will not alter recorder's performance on the first four ranges (0.5, 1, 5, 10mV/in). Higher source impedances will cause an increase in dead zone and a decrease in pen speed. No source impedance restrictions on ranges above 50 mV/in.

**Radio frequency interference:** meets specifications of MIL-I-6181D.

**Response time:** 0.6 sec. maximum, full scale.

**Time sweeps:** 5 calibrated sweeps: 0.5, 1, 5, 10, 50 sec/inch.

Metric: 0.2, 0.5, 2, 5, 20 sec/cm.

**Accuracy:** 0.2% at full scale; time sweep: 5% of full scale.

**Linearity:** 0.1% of full scale.

**Dead band:** 0.1% of full scale.

**Zero set:** continuously adjustable to any point on the graph paper or up to one full scale off the chart paper.

**Reference voltage:** continuous electronic reference, zener diode, controlled. Temperature stability better than 0.002%/°C.

**Writing mechanism:** independent isolated servo mechanisms for each axis. Liquid ink pen with ample ink supply.

**Paper holddown:** Autogrip electric paper holddown grips charts  $8\frac{1}{2}'' \times 11''$  or smaller; quiet and maintenance free with no moving parts.

**Pen lift:** local and remote pen lift.

**Accessories supplied:**

1. Accessory Kit: Contains spare fuse, slidewire cleaner, slidewire lubricant, set of Bristol wrenches, 2 pens, 1 bottle of green ink, 1 bottle of red ink, syringe.
2. Appropriate graph paper.
3. Power cord (7').
4. Flexible plastic dust cover.
5. Instruction manuals.
6. Carrying handle and wing brackets.

**Power:** 115 or 230 V, 50 to 60 Hz, 140 volt-amps.

**Dimensions:** table model: 14" high,  $17\frac{7}{8}''$  wide,  $4\frac{3}{4}''$  deep; (355 x 443,4 x 120,7 mm). Rack model: 14" high, 19" wide,  $4\frac{3}{4}''$  deep; (355 x 483 x 120,7 mm).

**Weight:** approximately 34 lbs (15,3 kg); shipping 47 lbs (21,2 kg).

**Prices:**

Models 136A/136AM \$2650

**Options:**

- |  |           |
|--|-----------|
| 02 Rear input terminals (2 sets with mating connectors)      | add \$15  |
| 03 5 k ohm linear retransmitting potentiometer in the X axis | add \$100 |

# RECORDERS



## 11" x 17" X-Y RECORDER

Low cost, multiple use

Model 7005A

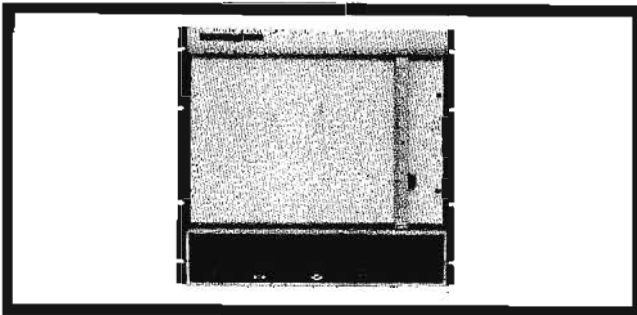

The Moseley Model 7005A is a high performance, low cost, solid state X-Y Recorder for general purpose applications not requiring high dynamic performance. Each axis has an independent servo system with no interaction between channels. The recorder will draw a graph of two related functions from two dc signals representing each of these functions. The instrument is convertible to rack mounting with only the addition of two wing brackets which are supplied with the model. Also available is a metrically scaled model (7005AM).

The input terminals accept either open wires or plug-type connectors. Five calibrated ranges from 1 millivolt/inch to 10 volts/inch are available in each axis. A variable range control allows any voltage, within the recorder limits, to be adjusted for full scale deflection. Standard features include high input impedance of one megohm (all but the first two ranges), floating and guarded inputs 0.2% accuracy, Autogrip electric paper holddown, electric pen lift, and adjustable zero set.

Extra cost options include locks for zero controls and for variable range controls, rear input connector, and retransmitting potentiometer. An external time base (Model 17108A) is also available and operates on either axis to provide five sweep speeds from 0.5 to 50 seconds per inch.

Each closed loop servo system employs a high gain solid state servo amplifier, Hewlett-Packard manufactured servo motor, long life balance potentiometer, photochopper, low pass filter, guarded inputs, precision attenuator and balance circuit. Model 7005A is designed for easy maintenance with most components mounted on a printed circuit board and accessible by removing only the rear cover. Both balance potentiometers are accessible for inspection or cleaning by simply removing a trim strip, requiring no tools. Also included are snap-on side panels and maintenance free Autogrip paper holddown.

### Specifications

**Input ranges:** 5 fixed calibrated ranges: standard: 1 mV/in., 10 mV/in., 100 mV/in., 1 V/in., and 10 V/in.; metric: 0.4 mV/cm, 4 mV/cm, 40 mV/cm, 400 mV/cm, and 4 V/cm; 5 variable ranges: continuous range adjustment from 1 mV/in. to 25 V/in. (0.4 mV/cm to 10 V/cm) provided by a high resolution control.

**Input resistance:**

Range	Input Resistance
1 mV/in. (.4 mV/cm) variable	Potentiometric (essentially infinite at null) 11k
10 mV/in. (4 mV/cm) variable	100k 100k
100 mV/in. (40 mV/cm) variable	1 meg 1 meg
1 V/in. (400 mV/cm) variable	1 meg 1 meg
10 V/in. (4 V/cm) variable	1 meg 1 meg

**Type of Inputs:** floating differential. All input terminals may be placed up to 500 V dc from ground. Critical circuit areas are guarded with guard terminal on front panel.

**Input isolation:** DC: 500 megohms (min) to ground at 500 V dc (all terminals). AC, Guard to Ground: 0.05  $\mu$ F.

**Effective guarded capacity:** 300 pF (capacity between + and - terminals, and chassis ground with guard shield driven).

**Interference rejection:** conditions for the following data is line frequency with up to 1 k ohm between the negative input and the point where the guard is connected. Maximum ac common mode voltage is 500 volts peak. Maximum dc common mode voltage is 500 volts.

Range		DC (CMR)	AC (CMR)
Standard	Metric		
1 mV/in	0.4 mV/cm	130 dB	95 dB
10 mV/in	4 mV/cm	110 dB	75 dB
100 mV/in	40 mV/cm	90 dB	55 dB
1 V/in	400 mV/cm	70 dB	35 dB
10 V/in	4 V/cm	50 dB	15 dB

**Input filter:** >20 dB at 60 Hz; -18 dB/octave above 60 Hz.

**Maximum allowable source impedance:** no restrictions except on fixed 1 mV/in. (.4 mV/cm) range. Up to 20 k ohm source impedance will not alter recorder's performance.

**Accuracy:**  $\pm 0.2\%$  at full scale.

**Linearity:**  $\pm 0.1\%$  of full scale.

**Dead band:**  $\pm 0.1\%$  of full scale.

**Standardization:** continuous electronic zener reference with temperature stability better than 0.002%/°C.

**Zero set:** zero may be placed anywhere on the writing area or electrically set off scale up to one full scale from zero index. Adjustable by a high resolution control.

**Stewing speed:** 15 inches/sec., 37 cm/sec. nominal at 115 V. (Typically 13 inches/sec at 103 V, 16 inches/sec at 127 V.)

**Paper holddown:** Autogrip electric paper holddown grips charts 11" x 17" or smaller. Writing area: 10" x 15" (25 cm x 37 cm).

**Pen lift:** electric pen lift capable of being remotely controlled. Connector supplied (#57-30240).

**Dimensions:** 17½" wide, 7½" high, 4-5/16" deep.

**Weight:** net approximately 18 lbs; shipping 24 lbs.

**Power:** 115 or 230 V  $\pm 10\%$ , 50 to 60 Hz, approximately 45 watts.

**Accessories supplied:**

- (1) Accessory Kit: containing slidewire cleaner, slidewire lubricant, set of Bristol wrenches, 2 pens, 1 bottle green ink, 1 bottle red ink, ink filling syringe, remote pen lift mating connector.
- (2) Appropriate graph paper.
- (3) Power Cord (7').
- (4) Rack mounting brackets.
- (5) Flexible plastic dust cover.
- (6) Instruction Manual.

**Price:**

Model 7005A	(Standard)	\$1195.
Model 7005AM	(Metric)	\$1195.

**Options:**

- 02 Lockable zero and variable range controls (both axes) \$15.
- 03 Retransmitting potentiometer on X axis  
Total resistance: 5 k  $\pm 3\%$   
Linearity (independent):  $\pm 0.1\%$   
Resolution: 0.04% \$75.
- 05 Rear input connector in parallel with front terminals \$15.

## TWO-PEN X-Y RECORDER

Three-channel for plotting two curves  
Model 2FA series



# RECORDERS

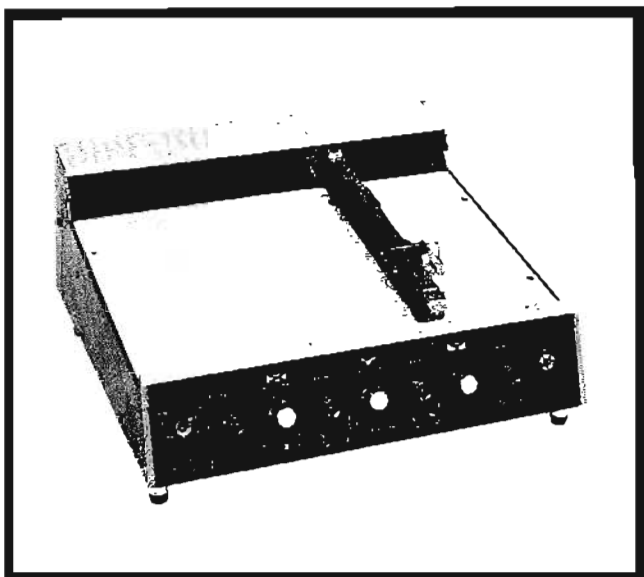

The 2FA is a three channel two-pen 11" x 17" graphic recorder, each channel presenting 1-megohm input resistance at null. It is available for rack mounting (2FRA) and with metric (2FAM, 2FRAM) instead of English scaling. Standard facilities include a time base on the x axis, 11 voltage ranges with continuous expansion feature, full scale zero set and suppression, local and remote electric pen lift and potentiometric capability.

Two drop-in mounted pens with integral ink reservoir traverse the full y axis with no less than 0.1 inch horizontal separation. Writing range for both pens is 10 inches vertically and 15 inches horizontally. Servo drives are independent and free of electrical ground. Servo amplifiers and power supply are combined in a single compact plug-in unit. A simplified self-balancing system uses linear slidewires and a continuous zener-controlled reference.

Each input range has a calibrated (fixed) and continuously variable mode. The variable mode may be used to fit arbitrary maximum voltages within the recording limits of the paper. Potentiometric operation on the four most sensitive ranges of each axis may be easily established by removing linkages on the input circuit boards. The built-in time base operates on the x axis, with five calibrated sweeps from 7.5 to 750 seconds for full-scale pen travel.

The exclusive electric paper holddown provides positive grip of charts 11" x 17" or smaller. Operation is silent with no moving parts and is maintenance free.

### Specifications

**Input ranges:** 11 calibrated ranges (each axis): 0.5, 1, 5, 10, 50 mV/inch; 0.1, 0.5, 1, 5, 10, 50 V/inch. Metric Models: 0.2, 0.5, 2, 5, 20, 50 mV/cm; 0.2, 0.5, 2, 5, 20 V/cm. Variable range mode all positions. Potentiometric input available on four most sensitive ranges of each axis by removing internal attenuator straps.

**Type of Inputs:** dc floating up to 500 V above ground.

**Input resistance:** one megohm at null on all fixed ranges. When in variable range mode, 100,000 ohms on four most sensitive ranges and one megohm on all others. Potentiometric input operation draws essentially zero current at null.

**Maximum allowable source impedance:** up to 10 K ohm source impedance will not alter recorder's performance on the first four ranges (0.5, 1, 5, 10 mV/inch). Higher source impedances will cause an increase in dead zone and a decrease in pen speed. No source impedance restrictions on ranges above 10 mV/in.

**Radio frequency interference:** meets specifications of MIL-I-6181D.

**Response time:** 1 sec full scale on X-axis; 0.5 sec full scale on Y<sup>1</sup> and Y<sup>2</sup>, maximum.

**Time sweeps:** 5 calibrated rates on X axis only: 0.5, 1, 5, 10, 50 sec/inch; metric: 0.2, 0.5, 2, 5, 20 sec/cm.

**Accuracy:** 0.2% of full scale. Time sweep: 5% of full scale.

**Linearity:** 0.1% of full scale.

**Dead band:** 0.1% of full scale on all ranges.

**Reference voltage:** continuous electronic reference, zener diode controlled. Temperature stability better than 0.002%/°C.

**Writing mechanism:** independent isolated servo mechanisms for three channels, X, Y<sup>1</sup>, Y<sup>2</sup>.

**Paper holddown:** autogrip electronic paper holddown grips charts 11" x 17" or smaller; quiet and maintenance free with no moving parts.

**Pen lift:** local and remote pen lift.

#### Accessories supplied:

1. Accessory kit: contains spare fuse, slidewire cleaner, slidewire lubricant, set of Bristol wrenches, 4 pens, 1 bottle green ink, 1 bottle red ink, ink filling syringe.
2. Appropriate graph paper.
3. Power cord (7').
4. Flexible plastic dust cover (bench models only).
5. Instruction manual.

**Power:** 115 or 230 V, 50 or 60 Hz, approximately 120 volt-amperes.

**Weight:** net approximately 42 lbs (18.9 kg); shipping 55 lbs (24.75 kg).

**Dimensions:** Bench Model: 18.87" (479 mm) deep, 17.50" (444 mm) wide, 8.25" (209 mm) high; Rack Model: 8" (203 mm) deep, 19" (483 mm) wide, 19.22" (488 mm) high.

#### Price:

- Model 2FA (standard bench)
- Model 2FRA (standard rack)
- Model 2FAM (metric bench)
- Model 2FRAM (metric rack), \$3375.

#### Options:

01. With rear input terminals (mating connector supplied), add \$15
02. With installed event marker, add \$100

# RECORDERS



## 11" x 17" HIGH SENSITIVITY

100  $\mu$ V/in dc; 5 mV/in ac (7000A only)

Models 7000A; 7001A

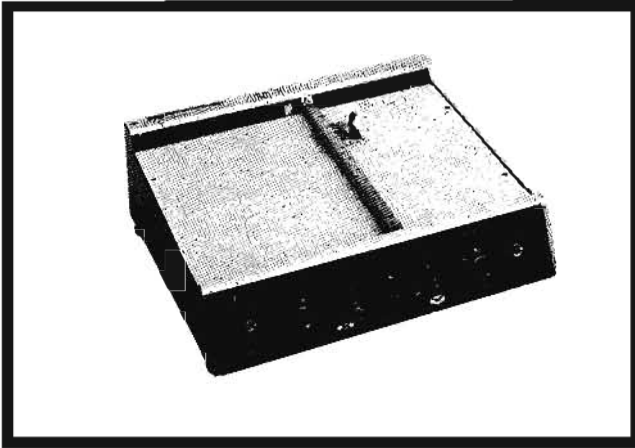

The Moseley 7000A X-Y recorder accepts dc or ac signals on either or both axes with high sensitivity and common mode rejection. The 7001A is identical to the 7000A except for the omission of ac input ranges. Specially guarded and shielded circuitry provides one megohm input resistance at null on all ranges. Units are available for rack mounting and with metric scales.

Any chart 11" x 17" or smaller may be held smoothly and firmly on the Autogrip electric platen which is silent in operation and maintenance-free. Flexibility is built into the electronic time base which may be switched to operate in either axis. Features include automatic reset, adjustable sweep length, and automatic recycling.

The plotting mechanism is greatly simplified by mounting the Y servo motor on the X carriage. Zero offset for each axis may be preset in calibrated 5-inch steps up to 4 full scale lengths in Y and 3 full scale lengths in X with continuous adjustability between steps. A dc accuracy of 0.2% of full scale holds when switching between ranges, making recalibration unnecessary during operation. All 7000A and 7001A models display extremely good retrace characteristics.

An ac sensitivity up to 5 mV/in (2.5 mV/cm) is a convenience when using Hewlett-Packard Model 1110A and 465A ac clip-on current probes for plotting low currents without additional amplification.

### Specifications

**DC Input ranges:** 17 calibrated ranges: 0.1, 0.2, 0.5, 1, 2, 5, 10, 20, 50, mV/in; 0.1, 0.2, 0.5, 1, 2, 5, 10, 20 V/in. Metric models: 0.05, 0.1, 0.25, 0.5, 1, 2.5, 5, 10, 25 mV/cm; 0.05, 0.1, 0.25, 0.5, 1, 2.5, 5, 10 V/cm. Plus continuously variable mode.

**AC Input ranges (7000A only):** 12 calibrated ranges: 5, 10, 20, 50 mV/in; 0.1, 0.2, 0.5, 1, 2, 5, 10, 20 V/in. Metric models: 2.5, 5, 10, 25 mV/cm; 0.05, 0.1, 0.25, 0.5, 1, 2.5, 5, 10 V/cm. The continuously variable mode is available on the dc ranges only.

**Type of Inputs:** dc floating up to 500 V above ground; guarded and shielded. AC input (7000A only) is single-ended, capacitor coupled.

**Input Isolation:** guard to ground capacity 0.002 mfd.

**DC Input resistance:** one megohm at null on all calibrated and variable dc ranges. Potentiometric input on 6 most sensitive ranges by disconnecting an internal buss wire. Potentiometric switch optional.

**AC Input Impedance:** (7000A only): one megohm on all calibrated ac ranges.

**Maximum allowable source impedance:** up to 10 k ohm source impedance will not alter recorder's performance on the first six ranges (0.1, 0.2, 0.5, 1, 2, 5 mV/inch). Higher source impedances will cause an increase in dead zone and a decrease in pen speed. No source impedance restrictions on ranges above 5 mV/in.

**Interference rejection:** dc common mode rejection 140 dB on 3 most sensitive ranges; 120 dB at power line frequency on 2 most sensitive ranges.

**Radio frequency interference:** meets specifications of MIL-I-6181D.

**Slewing speed:** 20 in/sec., maximum, each axis for 60 Hz; 16 in/sec., maximum for 50 Hz.

**Time sweeps:** may be applied to either axis in 8 calibrated ranges: 0.5, 1, 2, 5, 10, 20, 50, 100 sec/in. Metric models: 0.25, 0.5, 1, 2.5, 5, 10, 25, 50 sec/cm. Adjustable sweep length; may be reset or recycled at any point manually or automatically. Local and remote sweep controls.

**Accuracy:** dc: 0.2% at full scale; ac: 0.5% of full scale, 20 to 100,000 Hz; time sweep: 2% at full scale.

**Linearity:** dc: 0.1% of full scale; ac: 0.2% of full scale; time sweep: 1% of full scale.

**Dead band:** 0.1% of full scale on all ranges.

**Zero set (dc range only):** continuously adjustable with 5" calibrated steps for up to 3 full scale lengths on X and 4 on Y. Zero-check push button switches on each axis.

**Reference voltage:** continuous electronic reference, zener diode controlled. Temperature stability better than 0.005%/°C.

**Writing mechanism:** independent isolated servo mechanisms for each axis. Liquid ink pen with visually monitored cartridge.

**Paper holddown:** Autogrip electric paper holddown grips charts 11" x 17" or smaller; quiet and maintenance free with no moving parts.

**Pen lift:** local and remote pen lift.

**Accessories supplied:**

(1.) Accessory Kit: contains spare fuse, slidewire cleaner, slidewire lubricant, set of Bristol wrenches, 2 pens, 12 cartridges green ink, 12 cartridges red ink. (2.) Appropriate graph paper. (3.) Power cord (7'). (4.) Flexible plastic dust cover. (5.) Instructional manual.

**Power:** 115 or 230 V, 50 to 60 Hz, 85 volt-amperes.

**Dimensions:** bench model: 17½" wide, 15½" high, 6½" deep (445 x 382 x 165 mm); Rack model: 17½" inside rack clearance, 17½" panel height, 6½" maximum depth (444 x 444 x 165 mm).

**Weight:** net 38 lbs (17.1 kg); shipping 46 lbs (20.7 kg).

**Prices:** 7000A (standard bench); 7000AR (standard rack); 7000AM (metric bench); 7000AMR (metric rack): \$2495  
Moseley 7001A (standard bench); 7001AR (standard rack); 7001AM (metric bench); 7001AMR (metric rack): \$2175

**Options:**

01. Potentiometric switch for 6 most sensitive ranges:	add	\$55
04. 5 k ohms linear retransmitting slidewire on X-axis:	add	\$75
05. Rear input terminals	add	\$50
06. 5 k ohms linear retransmitting slidewire on Y-axis:	add	\$75
07. Retransmitting slidewire on both axes:	add	\$150

# DATA PLOTTING SYSTEM

Automatically plots in point or line form  
Model 7590C



## RECORDERS

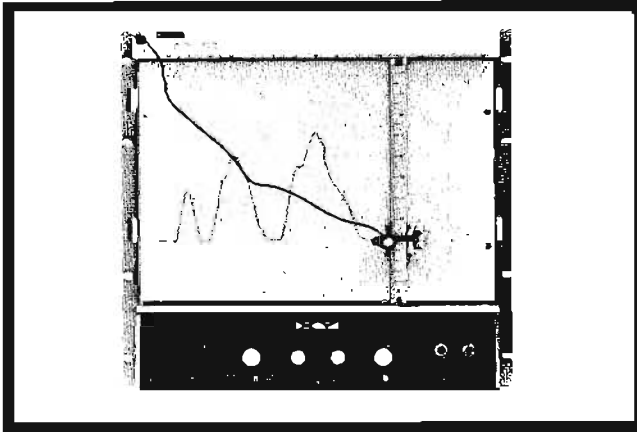

The Model 7590C is a specially equipped x-y recorder for automatically plotting electrical information in line or point form at a rapid rate. The basic recorder has standard features of 10 input ranges on each axis, all solid-state circuitry, floating inputs, drift-free servo mechanisms and mechanical paper holddown. Added to achieve automatic point or line plotting capability are a built-in null detector and a solenoid-actuated character printer. Character printer and pen are interchangeable, the one used being dependent on whether digital or analog information is being recorded.

The built-in 5-mode null detector is capable of plotting up to 360 points per minute. Mute mode requires a command from the data source to unmute the recorder servos. Any signal at the input which unbalances the servo will reposition the plotting carriage until a null or balanced condition is reached, at which time the servos are muted, a plot is accomplished, and a completed plot pulse is issued to an external control, causing the system to assume a standby status ready for the next command. No-mute mode is similar to mute mode except that a command is not required to unmute the servos. This allows the recorder to seek null as soon as an input signal is applied. Upon reaching balance, a plot is made, a completed plot pulse issued and the system returns to standby. A calibrated mode accepts a signal, balances but does not plot. This mode is useful in pre-run procedures. Line or point plotting, using pen or character printer, respectively, is established by a function selector.

The character printer supplied is similar to the 17009B with symbol stamp and actuating solenoid. Six symbols are furnished. Special characters are available at moderate cost.

### Specifications

**Recording mechanism:** An independent servo system for each axis (X and Y) non-interacting; transformer isolated and free of ground; rear input connectors.

**Slewing speed:** Fifteen inches/second (38 cm/sec) maximum speed, each axis.

**Plot rate:** 360 plots/minute, maximum.

**Paper size:** Standard 11" x 17" graph paper with a writing area 10" x 15". Metric unit: 25 cm x 38 cm graph paper. Mechanical paper hold-down. 10" x 120' roll charts when equipped with roll chart accessory (17006A).

**Input voltage ranges:** Ten fixed ranges each axis: 0.5, 1, 5,

10, 50 millivolts per division (inch) and 0.1, 0.5, 1, 5, 10, volts per division (inch). Metric unit: Ten ranges each axis: 0.2, 0.5, 2, 5, 20, 50 millivolts/centimeter and 0.2, 0.5, 2, 5 volts/centimeter. Stepless range control allows arbitrary full scale voltage setting. Recorder may be operated as a potentiometric recorder on most sensitive range.

**Input resistance:** 200,000 ohms/volt full scale (10") on all fixed ranges. Potentiometric mode provides essentially zero current drain at null.

**Standardization:** Long life mercury cell.

**Accuracy:** The most sensitive range, 0.5 mV/in (0.2 mV/cm on metric unit) is factory adjusted to 0.1% of full scale. 1% resistors are used in the attenuator. Resettability is 0.1% of full scale. Any one range may be calibrated to 0.1% of full scale by an easily accessible control.

**Interference rejection:** dc common mode rejection better than 10' to 1 on most sensitive range.

**Point plotting accuracy:** Better than 0.2%.

**Symbols furnished:** Six interchangeable dies with standard symbols; ink impregnated; print ten thousand impressions before re-inking.

**Dimensions:** Models 7590C, 7590CM: 17½" long, 16" deep, 6¾" high; Models 7590CR, 7590CMR: 17¾" inside rack clearance, 17½" high, 5½" maximum depth.

**Weight:** Approximate weight, either model: 28 pounds.

**Power requirements:** 115/230 volts, 50/60 Hz, approximately 110 volt-amperes.

**Forced plot:** If a null is not reached within approximately 2 seconds, a plot is forced.

**Enable/disable:** Required disable voltage: -3 volts, dc. Required enable voltage: from 0 volts dc to any plus potential. A contact closure may be substituted for the disable bias by inserting a resistor between existing terminals on the printed circuit board.

Voltage or contact closure requirements can be reversed by moving jumpers on the printed circuit board.

**Seek signal:** Minimum pulse height: ±3 volts; +10 to -20 volts, maximum range. Minimum pulse width: 2 microseconds. A seek signal is required for normal operation.

**Completed plot signal:** Pulse height: 20 volts; pulse width: 100 microseconds; rise time: less than 1 microsecond; maximum permissible capacitive load: .002 mfd; output impedance: less than 200 ohms (capacitor coupled).

**Line plot:** Points should not exceed a distance of 0.05" in order to obtain a smooth line segment presentation.

**Accessories supplied:**

1. Accessory Kit: Fuse, slidewire lubricant, set of Bristol wrenches, pen, 1 ink cartridge green ink, 1 ink cartridge red ink, pen cleaning wire.
2. Appropriate graph paper.
3. Power cord (7').
4. Flexible plastic dust cover.
5. Instruction manual.
6. Character Printer Accessory Kit: Wooden storage box, printing ink (Black) and Bristol wrench.

**Price:**

Model 7590C (standard)

Model 7590CR (standard rack)

Model 7590CM (metric)

Model 7590CMR (metric rack)

\$1985

**Options:**

01. Autogrip paper holddown add \$95.

03. Zener reference supply add \$120.



# RECORDERS



## 11" x 17" X-Y RECORDERS

High Z input; time base or computer reference

Models 2D-2, 2D-3

Moseley 2D-2 and 2D-3 Series X-Y Recorders offer a wide choice of features in options tailored for almost any application. The 2D-2 Series are basically general-purpose plotters, including models with electronic time base and 1 megohm input resistance. Recorders in the 2D-3 Series are specially equipped to accept the standard +100 and -100 volt computer reference as the servo balancing potential; they have an input resistance of 200,000 ohms/volt and do not include a time base. Other features of the two series are electrically and mechanically identical and include the new Autogrip® electric paper hold-down system, which has no moving parts, is quiet, maintenance-free and grips any size chart 11" x 17" or smaller.

All 2D-2 and 2D-3 recorders are completely solid state except the 1-megohm models which use a single nuvistor in each axis to provide the extra gain required.

As on all Moseley recorders, range selectors include a scale factor vernier which continuously extends the full-scale voltage acceptance of any range to permit on-scale recording of data within arbitrary limits. Potentiometric operation on the most sensitive range of 2D-2 models is possible by making a simple internal circuit board modification, and on 2D-3 models by a function switch selection.

The 2D-3 models include zero check pushbutton switches on each axis for convenience in checking computer reference calibration. Although specially designed for computer table use, 2D-3 recorders also have a standard internal electronic reference which may be utilized when operated as a standard plotter. Rack models and metric scaling are available for both recorders.

### Specifications

**Input ranges:** Model 2D-2/2D-3: 0.5, 1, 2, 5, 10, 20, 50 mV/inch; 0.1, 0.2, 0.5, 1, 2, 5, 10, 20, 50 V/inch. Model 2D-2M/2D-3M (metric): 0.2, 0.5, 1, 2, 5, 10, 20, 50, 100 mV/cm; 0.2, 0.5, 1, 2, 5, 10, 20 volts/cm. Model 2D-2A (one megohm): 0.5, 1, 5, 10, 50 mV/inch; 0.1, 0.5, 1, 5, 10, 50 volts/inch. Model 2D-2AM (one megohm metric): 0.2, 0.5, 2, 5, 20, 50 mV/cm; 0.2, 0.5, 2, 5, 20 volts/cm.

Scale factor vernier on all models. Potentiometric operation on 2D-2 Series on most sensitive range by removal of internal connection (effective on four most sensitive ranges of one megohm models). Potentiometric mode on selector switch of each axis on 2D-3 Series

### Types of inputs

**Model 2D-2:** floating differential inputs. All input terminals may be placed up to 500 V dc above ground. AC input is single-ended.

**Model 2D-3:** inputs single ended to ground for computer operation, switched to floating when operated on internal reference.

### Input resistance

**Model 2D-2 and 2D-3:** 200,000 ohms/volt full scale (10") through 1 V/inch; 2 megohms on all higher ranges.

**Model 2D-2M and 2D-3M (metric):** 200,000 ohms/volt full scale (25 cms) through 0.5 volt/cm range; 2.5 megohms on all higher ranges.

**Model 2D-2A (one megohm) and 2D-2AM (one megohm metric):** one megohm at null on all fixed ranges. When in the variable range control mode, 100,000 ohms on four most sensitive ranges and one megohm on all others.

On all models potentiometric operation draws essentially zero current at null. One megohm input resistance not available on Model 2D-3.

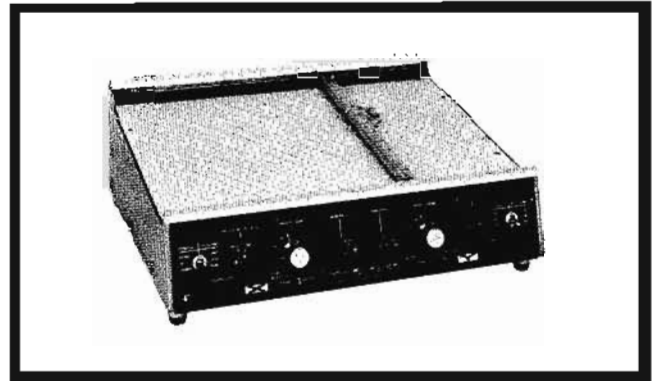

**Accuracy:** 0.2% of full scale on all ranges.

**Time base (except 2D-3):** 5% of full scale, adjustable to 1%.

**Dead band:** 0.1% of full scale on all ranges.

**Linearity:** 0.1% linearity on all ranges.

**Standardization:** continuous zener reference with temperature stability better than 0.002%/°C. Model 2D-3 may also be operated from an external ±100 volt computer reference (HO1-2D-3 accepts ±10 volt reference).

**Time sweep speed x-axis only (except 2D-3):** Model 2D-2: 0.5, 1, 2, 5, 10, 20, 50 sec/inch. Model 2D-2M (metric): 0.2, 0.5, 1, 2, 5, 10, 20 sec/cm. Model 2D-2A (one megohm): 0.5, 1, 5, 10, 50 sec/inch. Model 2D-2AM (one megohm metric): 0.2, 0.5, 2, 5, 20 sec/cm.

**Zero set:** zero may be placed anywhere on the writing area or electrically set off scale up to one full scale from zero index. Adjustable by a multi-turn potentiometer located on the control panel.

### Slowing speed

**60 Hz operation:** 20 inches/sec maximum (50 cm/sec).

**50 Hz operation:** 17 inches/sec maximum (42 cm/sec).

**Paper holddown:** Autogrip electric paper holddown holds charts 11" x 17" or smaller. Writing area 10" x 15" (25 cm x 38 cm).

### Dimensions

**Bench models:** 17½" wide, 16½" deep, 7" high.

**Rack models:** 17¾" inside rack clearance, 17½" high, 19" wide, 5¼" depth inside rack.

**Weight:** bench models: 34 lbs (net), 47 lbs (shipping). Rack models: 43 lbs (net), 52 lbs (shipping).

**Radio frequency interference:** meets specifications of MIL-I-6181D.

**Power:** 115/230 volts ac, 50/60 Hz, approximately 143 volt-amps for the 2D-2, and 88 volt-amps for the 2D-3.

### Price:

Model 2D-2 (any model in series) \$1950

Model 2D-3 (any model in series) \$2050

Model HO1-2D-3 (accepts ±10 V dc external computer reference in place of standard ±100 V dc external reference) \$2075

### Options:

01 Rear input connectors (rack units only): add \$ 15

02 Event marker (lower margin of X-axis): add \$100

03 Retransmitting potentiometer, 5 k, Ω  
0.1% linearity, X-axis: add \$ 50

04 Cartridge ink supply: n/c

06 Retransmitting potentiometer, 5 k, Ω  
0.1% linearity, Y-axis: add \$ 50

07 Retransmitting potentiometer, both axes: add \$100



## RECORDERS

### Strip chart and oscillographic recorders



## RECORDERS

Much of the instrumentation which extends, refines or supplements human perception produces information in the form of electrical analog signals. Records of such data are, of course, often required. Electrical data acquired in serial fashion, comprising a chain of meaningful changes in a signal, record naturally on continuous instruments such as strip chart recorders or oscillographic recorders. The character of the signal will determine the appropriate recording instrument. Analog records of slowly changing (<1 Hz) values are conveniently made by Hewlett-Packard servo-driven strip chart recorders.

Laboratory and industrial type recorders are available and produce records in rectilinear co-ordinates with considerable accuracy — typically 0.2%. Two-pen models permit both channels to realize the full resolution of the chart width simultaneously, since the pens can overlap on the same chart without interference. Active research on strip chart recorders has yielded high reliability, improved writing systems and other advances. Important features are: solid state circuitry, reliability, electric writing, optical slidewires, modular construction, versatile multi-range performance for laboratory applications, wide choice of single range performance for industrial applications.

#### Basic operation

Each Hewlett-Packard servo-driven strip-chart recorder uses an individual electrical servo system for each channel employed. All servos are similar. Each consists of a basic balancing circuit, plus auxiliary elements for instrument versatility.

The self-balancing potentiometer circuit compares an unknown external voltage with a stable internal reference voltage. The difference between these voltages is amplified and applied to a servo motor to drive a potentiometer in a direction that will null any difference or error voltage. Accuracy of plots made by this principle is typically 0.2%. The full-scale span of the recorder for each channel is obtained with input signals as low as one millivolt. Thus, the output of many low-level devices, such as thermocouples and strain-gages, may be plotted directly without additional amplification.

A stepped attenuator or span selector is included for each channel, so voltages as high as 100 volts full scale may be handled directly. Input resistance is at least 200,000 ohms per volt, with higher values, including constant 1-megohm in-

put resistance, available on most models. Sensitivity may be as high as 100 microvolts per inch.

Zero controls provide adjustment of electrical zero to any position on the chart and one full scale zero suppression.

#### Types of writing systems

Hewlett-Packard strip chart recorders provide three types of writing systems: ink, pressure stylus, and electric writing.

Ink recording is standard and still the most generally used writing method. Hewlett-Packard recorders employ the capillary ink feed system in which the ink supply is a cartridge or tank. After priming, flow is maintained by the capillary process.

Pressure-sensitive paper may be used on Model 680 recorders. When this mode of writing is employed, the pen is replaced with a stylus. The stylus exerts pressure on the pressure-sensitive paper, resulting in a display. The main advantage is elimination of pen clogging and the need to replenish ink supply, thus enabling unattended operation.

Electric writing is also available on most strip chart recorders. With the elimination of ink refilling, long term unattended recording with maximum reliability is possible. Electric writing features crisp, clean, permanent records with the advantage of instant start-up. It is not sensitive to light or pressure, eliminating special handling; it is odorless and permanent, without processing.

#### Options and accessories

A variety of options and accessories is available to customize the recorder for

individual applications. Options include event markers, retransmitting potentiometers, remote electric pen lift, remote chart drive switch, disc integrator, limit switches, etc.

Available accessories include input filters, logarithmic converters, line followers, BNC adapters, etc.

Most special applications can be satisfied by using one or more of the available options and accessories.

#### Industrial recorders

Requirements for industrial strip chart recorders are more critical than those for laboratory recorders. The main factors to be considered before purchasing a recorder are desired performance, length of continuous unattended operation, and the maximum down time that can be tolerated. An often overlooked consideration is how readily and inexpensively can the recorder be converted for use in applications *other* than those for which it is originally purchased. The versatility of the instrument should be carefully analyzed.

Hewlett-Packard industrial strip chart recorders are completely modular in design. This provides three definite advantages: (1) Selection of a low cost recorder tailor-made to the measurement need. (2) Isolation of faults to modules, any of which may quickly be replaced. (3) Special or optional modules may be purchased later if requirements for the recorder change.

Unattended operation for long periods of time is possible with long roll charts and large ink reservoirs, or electric writ-

Hewlett-Packard strip-chart recorders

Model	Use	Writing width	Pens	Price	Chart speeds	Speed range	Voltage range (full-scale)
680	Laboratory	5"	1	\$750	8	8"/min - 1"/hr	5 mV to 100 volts
H01-680	Laboratory	5"	1	\$800	8		1 mV to 100 volts
7101B	Laboratory	10"	1	\$1000 (main frame only)	12	2"/sec - 1"/hr	Input Modules 17500A: 5 mV - 100 V, \$250 17501A: 1 mV - 100 V, \$350 17502A: single span to match thermocouple, \$250 17504A: single span; 5 mV - 100 V, \$200
7100B	Laboratory	10"	2	\$1300 (main frame only)	12	2"/sec - 1"/hr	
7127A	Laboratory-Industrial	10"	1	\$850 (main frame only)	4	1/4"/min - 2"/min or 6"/hr - 48"/hr or, 1.5"/hr - 12"/hr.	1 mV
7128A	Laboratory-Industrial	10"	2	\$1150 (main frame only)	4	Same as 7127A	
7127A plus 17503A	Gas chromatography	10"	1	\$1100	4	Same as 7127A	1 mV
7128A plus 17503A	Gas chromatography	10"	2	\$1400	4	Same as 7127A	1 mV
5701A	Industrial	6"	1	\$825	1	Single range 10"/min - 0.5"/hr	Single span 1 mV to 100 V
5703A	Industrial	11"	1	\$995	1		
5700A	Industrial	6"	2	\$1325	1		
5702A	Industrial	11"	2	\$1895	1		

# RECORDERS



## RECORDERS continued Strip chart and oscillographic recorders

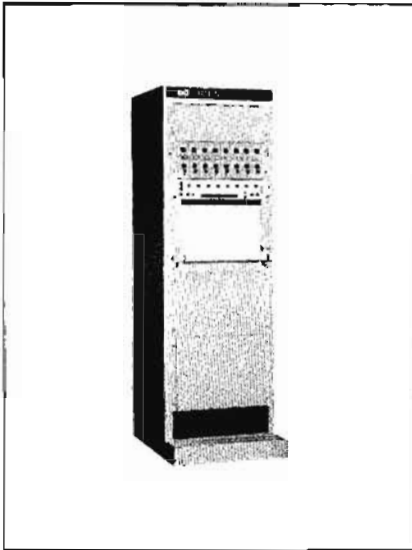

7708A Recorder

ing. Balance potentiometers are available with *no moving contact*, virtually eliminating maintenance, and insuring long life.

### Direct-writing galvanometer recorders

A considerable proportion of data recording requirements is for continuous, visible analog records of signals with maximum significant frequency content in the range 30 to 150 Hz. These needs are well filled by direct-writing instruments operating on the galvanometer principle. In the Hewlett-Packard family are four extensive series of Sanborn recorders in this category. Three produce inkless, rectilinear traces on matched thermo-sensitive Permapaper® by the hot stylus method. Linearity of 0.5% full



7858A Recorder

scale, resolution of 4 cycles/mm of paper travel even at small amplitudes, and reliable operation without attention to the writing medium are significant advantages of the Sanborn thermal writing method. Standard versions are available with 1, 2, 4, 6, 8 and 16 channels.

The fourth recorder—Model 7858A—produces rectilinear traces in instant-drying ink on Hewlett-Packard Z-fold paper or rolls. This compact, solid-state eight-channel recorder utilizes a pen position feedback technique providing greater accuracy for true rectilinear recording of analog signals for applications involving telemetry systems, medical instrumentation systems and analog computers. A pressurized ink system, with plug-in ink reservoir produces ultra-clear traces throughout a speed range of .025 to 200 mm/sec. The 7858A also features a frequency response of dc-150Hz (−3 dB) at 10 div pp deflection and 60 Hz (max.), for full-scale deflection. Linearity is 0.5% full-scale.

These recorders are well suited for data recording applications in scientific and industrial research, production and environmental testing, quality control, communications, telemetry, and process control. In the medical field, they are designed for use in cardio-pulmonary and catheterization laboratories, and a wide range of research, clinical and teaching applications.

The Sanborn Division also offers smaller one- and two-channel recorders, some of the portable type, which uniquely fill many purposes. Among these, Model 7701A achieves two to three times the resolution of conventional direct-writing recorders by offering response of 30 Hz across the full 100 mm of its chart width. It accurately displays critical levels of force, velocity, strain, displacement and other measurements with unmatched clarity.

A broad line of amplifiers and signal-conditioners matches the Sanborn thermal direct-writing recorders to transducers, including direct and carrier types. These amplifiers include: individual-channel plug-ins of (1) a highly versatile, maximum-signal-control design using tube and solid-state circuitry (11 models) and (2) miniaturized all solid-state versions available in seven models; 6 or 8 identical amplifier channels on a common plug-in chassis are available in four types

There also are important needs for continuous, visible analog records of signals with significant content in the frequency

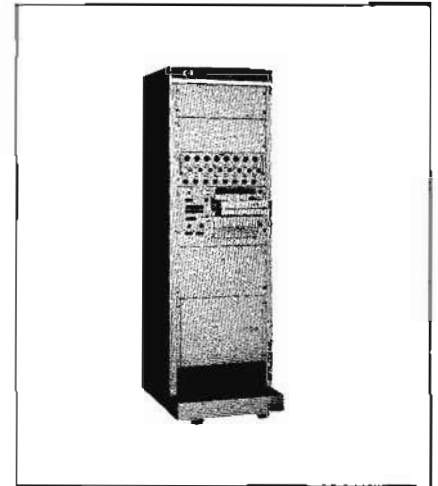

4508A Recorder

range 0 to 5 kHz or more. These are well met by Sanborn direct-writing high-speed optical recorders. They are ideal for monitoring and recording such variables as temperature, pressure, force, displacement, strain, computer and power supply outputs in missile and engine analysis, analog recording, production testing, control applications and nuclear tests. They employ compact, high-speed galvanometers to direct light beams, recording at amplitudes up to 8" on photo-sensitive paper. Rectilinear charts are produced, and traces may overlap. Standard versions are available up to 25 channels. One series of these highspeed Sanborn optical recorders writes with high-intensity ultra-violet light, to produce almost-immediately visible traces which require no chemical development; another series writes with light originating in incandescent lamps, producing traces of high contrast on photosensitive paper stock of lower cost, but requiring chemical development. This, however, may be accomplished rapidly and continuously by an optional automatic rapid developer attachment to the recorder.

The same wide options among amplifiers and signal-conditioners are offered both for optical and for thermal-writing instruments.

Excellence of performance in all types of galvanometric recorders depends heavily upon the paper medium used. Sanborn quality-controlled papers play a large part in determining the resolution and reliability of these instruments. Standard papers are available in a wide variety to suit a broad range of general and special applications, and custom services are offered where needed.

## 6" STRIP CHART RECORDER

Multi-speed servo recorder  
Model 680



# RECORDERS

The Models 680 and 680M, 6" strip-chart recorders provide a wide range of performance for general or specialized use. The 680 is equipped with multi-range input, multi-speed chart transport, full-range zero set, and electric pen lift; features essential for general purpose applications. The instrument is available with standard (English) or metric scaling (680M) and extra cost options such as retransmitting potentiometers, event markers, limit switches, and dual rack adapter for rack mounting in pairs. It is useful for recording the output of HP Digital recorders such as the Model 562A when equipped with two D/A converters such as the Model 581A.

The recorder features modular construction with all transistor circuitry, high accuracy, fast response, synchronous motor chart drive and full view tilting chart magazine. Standard facilities include instant chart speed transfer, local and remote pen lift control, tear-off or chart roll storage, and a choice of cartridge-fed ink pen or pressure stylus. Optional electric writing provides crisp, clean, permanent records for long-term unattended recording capability.

### Specifications

#### Recording mechanism:

**Ink:** servo actuated ink pen drive, free of ground, with local and remote pen lift and full scale zero adjustment.

**Pressure sensitive:** similar to ink mechanism except a stylus for pressure sensitive paper is furnished in place of the ink pen.

**Electric:** similar to ink mechanism except a stylus for electrosensitive paper and the associated electronics are furnished in place of the ink pen.

#### Chart requirements:

**Ink:** 6" by 100' roll charts, 5 inch (12 cm) writing width. Approximately 4" by 6" visible chart area during operation.

**Pressure sensitive:** 6" by 80' roll charts, 5" (12 cm) writing width.

**Electrosensitive:** 6" by 80' roll charts, 5" (12 cm) writing width.

**Response time:** one-half second or less for full scale.

**Chart speeds:** eight-synchronous motor controlled speeds at, 1, 2, 4, 8 inches per minute; 1, 2, 4, 8 inches per hour. Metric model: 2.5, 5, 10, 20 centimeters per minute; 2.5, 5, 10, 20 cm per hour. Speeds in a ratio of 16 to 1 may be supplied at additional cost.

**Spans:** ten calibrated spans of 5, 10, 50, 100, and 500 millivolts; 1, 5, 10, 50, and 100 V full scale. Metric model has spans of 6, 12, 60, 120, and 600 millivolts; 1.2, 6, 12, 60, and 120 V. An extra span of 1 millivolt, full scale, is available at extra cost (1.2 mV on metric).

**Input resistance:** 200,000 ohms per volt (166,666 ohms/volt on metric models) full scale, through 10 volt spans; 2 megohms on all others. Potentiometric input on most sensitive span permits operation with essentially zero current drain at null. Constant 100,000 ohm input resistance on all spans available at extra cost on both models.

**Standardization:** continuous electronic reference from zener diode controlled power supply.

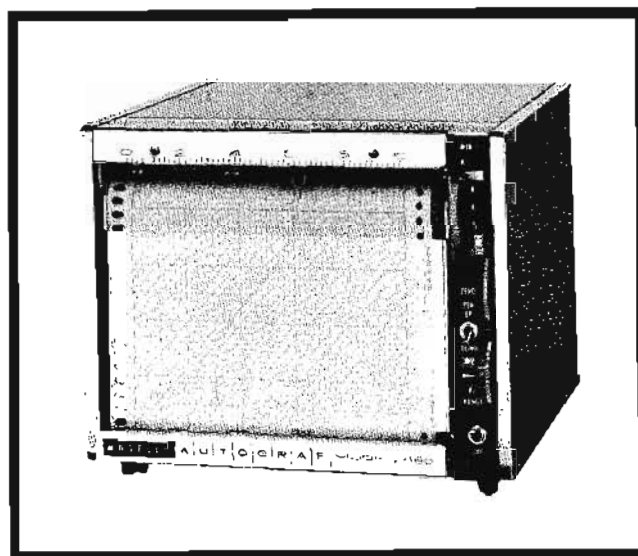

**Accuracy:** better than 0.2% of full scale. Resettability: 0.1% of full scale.

**Interference rejection:** dc common mode rejection better than 100,000 to 1 on 5 millivolt span.

**Power requirements:** 115/230 volts, 60 Hz, 22 volt-amperes, 50 Hz models available at no extra cost, Option 10.

**Physical dimensions:** 6 1/2" (165 mm) high, 8-3/5" (219 mm) deep, 7 3/4" (197 mm) wide. Rack mounting requires 7 inches of vertical space.

**Weight:** net approximately 11 lbs (5 kg); shipping 17 lbs (7.6 kg).

**Accessory kit supplied:** spare fuse, pen cleaning wire, slide-wire cleaner and lubricant, 2 ink cartridges (red and blue), set of Bristol wrenches, and a roll of appropriate chart paper.

#### Prices:

Models 680 (standard) or 680M (metric):	\$750
Model H01-680 or H01-680M (with added span of 1 mV on H01-680 or 1.2 mV on H01-680M):	\$800
Model H02-680 or H02-680M (with 100,000 ohms input resistance on all spans):	\$825

#### Options:

—01 With installed 5k, 0.1% linearity retransmitting potentiometer:	add	\$50
—02 With installed event marker:	add	\$25
—03 With installed limit switches:	add	\$90
—08 With 16 to 1 instead of 60 to 1 speed reducer:	add	\$25
—09 With remote chart drive switch:	add	\$25
—10 For 115/230 V, 50 Hz operation:	n/c	
—11 With special scale markings:	add	\$10
—12 With stylus for pressure sensitive paper:	n/c	
—13 For operation with Logarithmic Converter:	add	\$25
—14 Glass door with lock:	add	\$45
—15 Electric writing:	add	\$75

# RECORDERS



## INDUSTRIAL RECORDERS

6" and 11" calibrated spans

Model 5700A Series

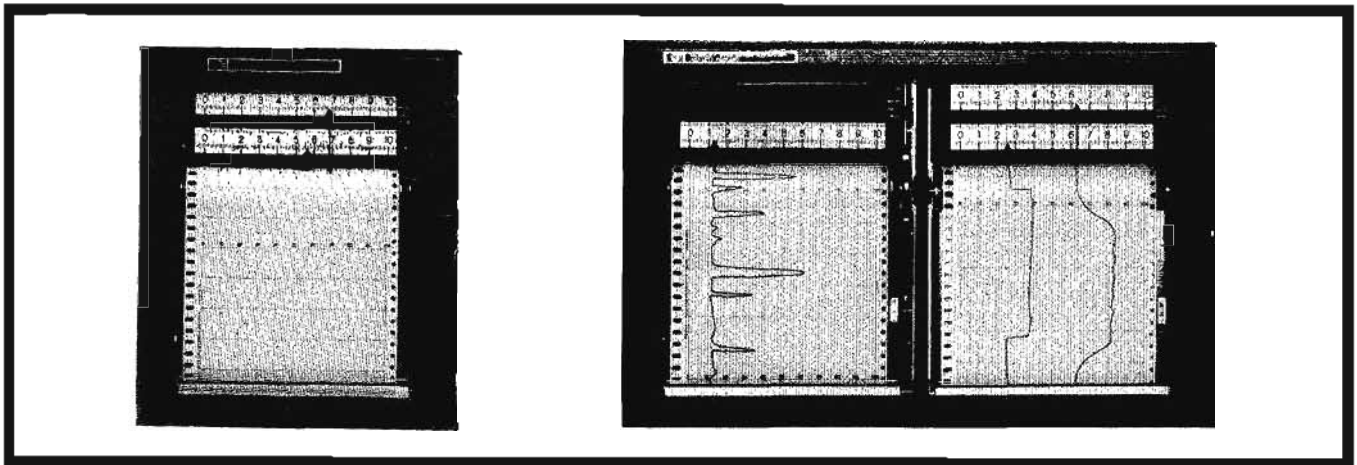

The HP Industrial Strip Chart Recorders are dual and single channel instruments designed for installation in racks or on industrial panels. Four models are available—single pen and two pens in both 6 inch and 11 inch spans.

The modular concept used in these recorders provides standardization of subassemblies within the entire line of recorders. Like modules may be interchanged between recorders or quickly removed and replaced in case of malfunction. Servo module, amplifier, range card, control panel, chart magazine, chart motor, and even the entire frame are modular and may be replaced in approximately 5 minutes without removing the instrument from the line. Fault isolation to modules and replacement of defective module may be accomplished rapidly. This minimizes "on line" down time and allows repairs to be performed by skilled personnel in instrument maintenance shops.

This modular concept is a realistic approach to providing the ultimate in dependability. The instrument still maintains the highest degree of reliability and trouble-free operation.

The modular design also allows instruments to be modified on the line to meet changing requirements. A one pen recorder may be converted to a two pen recorder by adding an identical servo module and amplifier. New speeds and spans may be obtained by simply plugging in a new motor gear box and/or range card. These modifications may be accomplished within minutes in the field.

Isolated operation for long periods of time is possible with 120 foot roll charts and a large ink reservoir. High reliability is achieved by the all-new solid-state circuitry, zener reference, and Moseley developed multi-contact flat mandrel potentiometers. Optional Moseley exclusive non-contacting potentiometers (6" recorder only) provide long life and low maintenance, due to no moving contacts. A roll out carriage offers access to all components and allows quick removal of the instrument from the case.

The tilt-out chart magazine locks in two extended positions, 30° and 45°. These positions are designed to aid in writing notes on the graph paper during recordings. A chart paper supply indicator is a standard feature on both models.

Each pen has an individual scale. Special scales are available.

Input connections are made to terminals located on the rear of the recorder. The input may be floated to  $\pm 500$  V dc. All models are supplied with a single span per channel and single speed. The appropriate model number for the desired span (range card) may be selected from Figure 2. Each range card contains a precision adjustable potentiometer allowing range card calibration over a 2.1 span (minimum). The plug-in range card may be quickly changed without removing the instrument from the panel.

A complete line of plug-in accessories is being developed to further enhance the capability of the recorders. All models are designed to accept plug-ins such as temperature module with automatic compensation of reference junction with changes in ambient temperature, adjustable zero and adjustable span, automatic ranging, and others.

### Options

A variety of options is available to customize the recorder for each individual application. These options include: Up to two event markers per instrument; one retransmitting potentiometer per channel; up to 8 "dry circuit" limit switches per channel, each rated at 100 V, 250 milliamps (limited to 8 per instrument); remote electric pen lift, each pen actuated individually by a contact closure; input burnout protection; remote chart switch; power switch omitted; and electric writing.

New Hewlett-Packard developed electric writing provides instant startup and crisp, clean, permanent records. It eliminates ink refilling providing long term unattended recording capability, is not sensitive to light or pressure, and is odorless and permanent without processing. Electro-sensitive paper offers uniform traces at all recorder speeds and is ideal for many critical applications. All of the above options may be simultaneously included in a recorder. An accessory cable (Option 20) is required for certain options as shown in the specifications.

**Specifications**

**Span:** single span (selected from Figure 2).  
**Input impedance:** input operates in a potentiometric mode with spans from 1 to 100 mV, providing infinite impedance at null. With spans above 100 mV input impedance is a constant 1 megohm.  
**Interference rejection:** transverse interference (normal mode) 60 dB at 60 Hz (60 dB at 50 Hz with Option 19). Longitudinal interference (common mode) 120 dB at power line frequency.  
**Span step response time:** 0.5 second maximum at 50 or 60 Hz—5700 and 5701; 0.7 second maximum at 60 Hz (0.8 sec 50 Hz)—5702 and 5703.  
**Chart requirements:** 5700A/5701A: 7 inch by 120 foot roll charts, 6 inch calibrated width. 5702A/5703A: 12 inch by 120 foot roll charts; 11 inch calibrated width.  
**Accuracy:** ±0.25% or 5 microvolts, whichever is greater.  
**Dead band:** ±0.1% or 5 microvolts, whichever is greater.  
**Terminal-based linearity:** ±0.1%.  
**Zero adjust:** continuously adjustable one full scale to the right or left of the zero position.  
**Standardization:** continuous electronic Zener reference.  
**Source impedance:** 10 k maximum on potentiometric input range cards. Unrestricted on 1 meg. range cards.  
**Chart speed:** single chart speed (selected from Figure 1). Motor may be easily changed. Extra chart drive motors for speeds from Figure 1 available at \$20.

**Available chart speeds—select one for each recorder:**

0.5 in/hr	10 in/hr	72 in/hr
1 in/hr	12 in/hr	90 in/hr
2 in/hr	15 in/hr	2 in/min
3 in/hr	20 in/hr	3 in/min
4 in/hr	30 in/hr	5 in/min
5 in/hr	36 in/hr	6 in/min
6 in/hr	60 in/hr	10 in/min

Figure 1. Chart Speeds

**Recording mechanism:** servo actuated pen drive; floating and guarded input; mechanical pen lift. One large ink reservoir for each channel.  
**Power requirements:** 115 volts; 60 Hz. 115 volt-amps (basic).  
**Physical dimensions:** 11" and 6" dual rack models: 19" wide, 12 1/4" high, 15" deep. 6" single enclosure. 10-3/5" wide, 12 1/4" high, 15" deep.  
**Weight:** 5701 net approximately 30 lbs, shipping 42 lbs. 5703 net approximately 42 lbs, shipping 55 lbs.  
**Accessory kit supplied:** spare fuse, slidewire cleaner, slide-wire lubricant, 1 bottle of ink per channel (red and green, 5700A and 5702A only), set of Bristol wrenches, a roll of appropriate graph paper, a package of 5 pen tips (disposable), syringe, and tubing.

**Prices:**  
 5700A—6" 2 pen \$1325  
 5701A—6" 1 pen \$ 825  
 E01-5700A (5700A/5700A in one cabinet) \$2560  
 E03-5701A (5701A/5701A in one cabinet) \$1560  
 E02-5700A (5700A/5701A in one cabinet) \$2060  
 5702A—11" 2 pen \$1895  
 5703A—11" 1 pen \$ 995

**Options:**  
 01 6 inch recorder in left side of dual case n/c  
 02 6 inch recorder in right side of dual case n/c  
 03 Air purged case \$ 50

- \*04 Right-hand Event Marker \$ 35
- \*05 Left-hand Event Marker \$ 35
- \*06 One retransmitting potentiometer (channel #1\*\*) 1 k ohm standard \$ 55
- \*07 One retransmitting potentiometer (channel #2) 1 k ohm \$ 55
- \*08 Limit Switch—1 each (channel #1\*\*) \$ 25
- \*09 Limit Switch—2 each (channel #1\*\*) \$ 50
- \*10 Limit Switch—3 each (channel #1\*\*) \$ 75
- \*11 Limit Switch—4 each (channel #1\*\*) \$100
- \*12 Limit Switch—1 each (channel #2) \$ 25
- \*13 Limit Switch—2 each (channel #2) \$ 50
- \*14 Limit Switch—3 each (channel #2) \$ 75
- \*15 Limit Switch—4 each (channel #2) \$100
- \*16 Remote pen lift (channel #1\*\*) \$ 40
- \*17 Remote pen lift (channel #2) \$ 40
- 18 Power Switch omitted \$ 15
- 19 50 Hz operation n/c
- 20 Accessory Cable \$ 15
- 21 230 volts operation n/c
- 22 Non-Contact Potentiometer (5701A only) Terminal based linearity 0.2% \$100
- 23 Non-Contact Potentiometer (5700A only) Terminal based linearity 0.2% \$200
- 24 Door Lock (Key) \$ 15
- 25 Electric Writing (5701A and 5703A) \$ 75
- 26 Electric Writing (5700A and 5702A) \$100
- 27 Jump Speed 10:1 \$ 50
- \*28 Remote On-Off Chart Control \$ 25
- 29 Zero Right (channel #1\*\*) \$ 15
- 30 Zero Center (channel #1\*\*) \$ 15
- 31 Zero Right (channel #2) \$ 15
- 32 Zero Center (channel #2) \$ 15
- 33 Jump Speed 60:1 \$ 50

**Range Card**

One range card (for input span selection) for each channel must be specified when ordering recorder.

**Specifications**

Span	Model Number	Input Impedance
1-3 mV/full scale	17550A	Potentiometric
3-10 mV/full scale	17551A	Potentiometric
10-30 mV/full scale	17552A	Potentiometric
30-100 mV/full scale	17553A	Potentiometric
100-200 mV/full scale	17554A	1 Megohm
200-500 mV/full scale	17555A	1 Megohm
500 mV-1 V/full scale	17556A	1 Megohm
1-3 V/full scale	17557A	1 Megohm
3-10 V/full scale	17558A	1 Megohm
10-30 V/full scale	17559A	1 Megohm
30-100 V/full scale	17560A	1 Megohm

Figure 2

**Span:** calibrated at factory to any full scale span within the range of the card.

**Price:** any of the above range cards, \$35.

Note: one card supplied at no charge with each channel of 5700A/5701A/5702A/5703A recorders.

**Options:**

- 01 Burnout Protection: an open input drives the pen to the right \$ 10
- 02 Burnout Protection: an open input drives the pen to the left \$ 10

\*Requires accessory cable Option 20.

\*\*Channel 1 is the lower pen.

# RECORDERS



## STRIP CHART RECORDERS

Versatile 10" recorders — with input modules

Models 7100B, 7101B

### Description

The 7100B Series recorders have a basic recorder frame with 12 speed strip chart transport which provides 10" strip chart recording capabilities. Each input channel accepts any of the wide variety of input modules which determine the electrical span or special purpose recording capability. The 7100B has two pens and takes two modules; the 7101B has one pen and takes one input module. Metric and rack mounting models are also available. Ordering information should

specify basic frame and exact input module or modules required.

Each main frame is equipped with a modular chart magazine which will swing out from its vertical position if desired to lock at a 10° angle for operational viewing or 30° for convenient note writing. Optional features available include event markers, electric pen lift, and chart drive start-stop (all remotely controllable). Retransmitting potentiometers, limit switches, and remote 10:1 speed changer are also available.

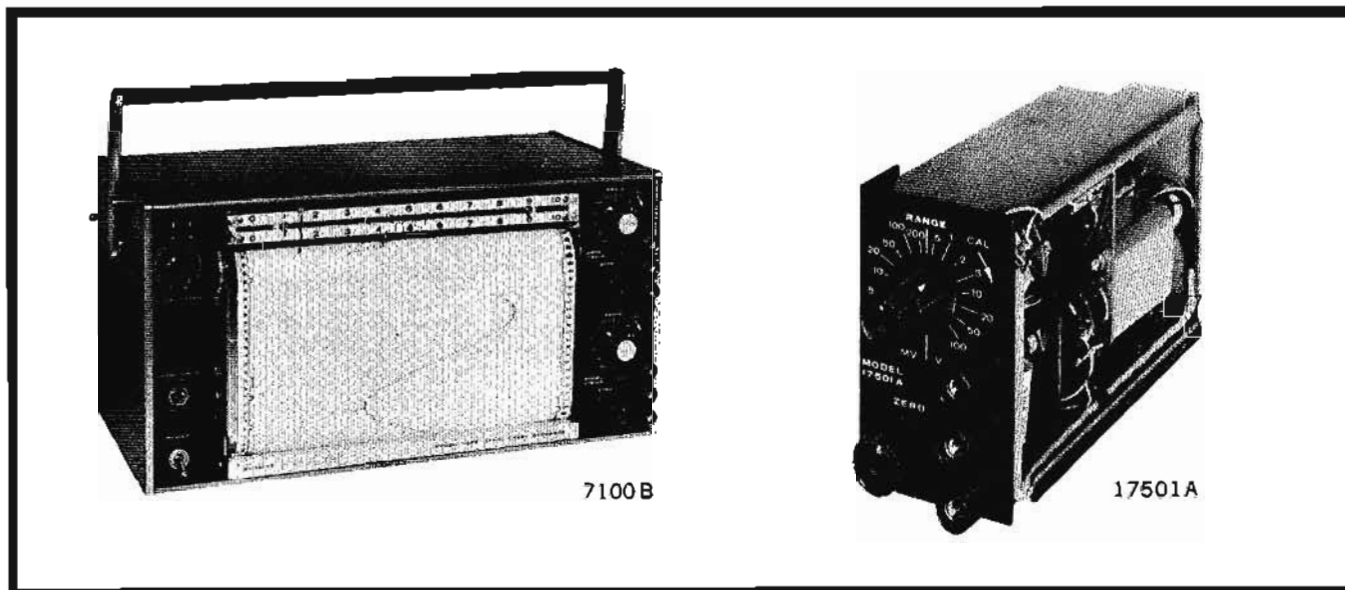

7100B

17501A

### Specifications

**Recording mechanism:** servo activated ink pen drives; manually operated pen lift.

**Response time:** maximum 0.5 sec. (50 Hz operation 0.6 sec.). (Reduce for some input modules.)

**Chart capacity:** 120' chart rolls 11" wide with 10" calibrated writing width.

**Chart speeds:** standard models: 1, 2 in/hr; 0.1, 0.2, 0.5, 1, 2 in/min; 0.1, 0.2, 0.5, 1, 2 in/sec; metric models: 2.5, 5, 15, 30, cm/hr; 1.25, 2.5, 5, 15, 30 cm/min; 1.25, 2.5, 5 cm/sec. Remotely controlled 10 to 1 speed reducer available at extra cost.

**Power:** 115 or 230 V  $\pm 10\%$ , 60 Hz, 65 volt-amperes for 7100. 42 volt-amperes for Model 7101B. 115 or 230 V, 50 Hz models available as option.

**Weight:** 7100B, net 22 lbs (9.9 kg), shipping 30 lbs (13.5 kg); 7101B, net 21 lbs (9.45 kg), shipping 28 lbs (12.6 kg). All weights exclude input modules.

#### Accessories supplied:

- Accessory kit contains: ink cartridge—4 each of red and 4 each of blue, set of Bristol wrenches, balance potentiometer lubricant, balance potentiometer cleaner, syringe and tube for ink system cleaning, extra pen for each channel, rear input mating connector, and pen cleaning wire.
- Appropriate graph paper (one 120' roll)
- Power cord (7')
- Instruction manual

**Dimensions:** 16 $\frac{3}{4}$ " long, 8-11/16" high, 7 $\frac{1}{4}$ " deep.

**Radio frequency interference:** meets specifications of MIL-I-6181D.

#### Prices: (basic frame less input module)

Dual channel Models 7100B (standard); 7100BR standard rack, 7100BM (metric), 7100BMR (metric rack): \$1300  
Single channel Models 7101B (standard), 7101BR (standard rack), 7101BM (metric), 7101BMR (metric rack): \$1000

#### Options:

- |   |           |
|---|-----------|
| 02 With 10 to 1 remote speed reducer:                             | add \$ 85 |
| 04 With 5000 ohm retransmitting potentiometer in channel #1:      | add \$ 50 |
| 05 With high-low limit switches (7101B and channel one on 7100B): | add \$ 50 |
| 06 Electric pen-lift with remote control:                         | add \$ 50 |
| 07 With remote on-off chart control:                              | add \$ 25 |
| 10 For 115 or 230 V, 50 Hz operation:                             | n/c       |
| 11 With latching glass door:                                      | add \$ 50 |
| 12 With left mounted event marker:                                | add \$ 35 |
| *14 With two event markers:                                       | add \$ 70 |
| *15 With Disc Integrator:   | add \$585 |
| *16 With 5000 ohm retransmitting potentiometer in channel #2:     | add \$ 50 |
| 17 With high-low limit switches (channel #2 on 7100B):            | add \$ 50 |
| 18 With high-low limit switches (both channels of 7100B):         | add \$100 |
| 19 Electric writing:  | add \$ 75 |
| 20 Scale with "o" right side:                                     | n/c       |
| 21 Gray Control Panel:  | n/c       |

\*Options 14, and 18 can not be installed when option 15 is installed.



### Input modules

For use with all 7100 Series Basic Frames

#### Description (17500A)

This multiple span plug-in offers high input resistance and continuously variable span control. The 17500A has ten calibrated spans from 5 mV to 100 V full scale. Inputs are floating up to 500 V above ground, have high common mode rejection, and present input impedance of one megohm at null on all calibrated spans. Combined with single or dual channel recorder frames, it offers an unexcelled, versatile, high precision strip chart recorder for general laboratory or industrial use.

#### Specifications (17500A)

**Voltage spans:** ten spans at 5, 10, 50, 100, 500 mV; 1, 5, 10, 50, 100 V, full scale; continuously variable mode on all spans and potentiometric operation on four most sensitive spans by removal of internal buss wire.

**Accuracy:**  $\pm 0.2\%$  of full scale.

**Linearity:** Terminal-Based: 0.1% of full scale.

**Dead band:** 0.1% of full scale.

**Input resistance:** 1-megohm at null on all fixed calibrated spans; when in variable mode, 100,000 ohms on four most sensitive spans, 1-megohm on all others.

**Interference rejection:** dc common mode, 120 dB on four most sensitive ranges; line frequency, 100 dB on four most sensitive ranges.

**Zero-set:** continuously adjustable over full scale, plus one full scale of suppression.

**Maximum source impedance:** up to 10 k ohm source impedance will not alter recorder's performance on the first four ranges (5, 10, 50, 100 mV/fs). Higher source impedances will cause an increase in dead zone and a decrease in pen speed. No source impedance restrictions on ranges above 100 mV/fs.

**Reference supply:** continuous electronic reference, zener diode controlled.

**Weight:** 4 lbs net, shipping 7 lbs.

**Price:** Model 17500A \$250

**Option:** 04 Gray control panel n/c

#### Description (17501A)

This multiple span plug-in offers high input resistance and continuously variable span control. The 17501A has sixteen spans from 1 mV to 100 V full scale. Inputs are floating up to 500 V above ground, having high common mode rejection, and input impedance of one megohm at null on all spans. Combined with the recorder frame, it offers an unexcelled, versatile, high precision strip chart recorder for general laboratory or industrial use.

#### Specifications (17501A)

**Voltage spans:** sixteen spans, 1, 2, 5, 10, 20, 50, 100, 200, 500 mV; 1, 2, 5, 10, 20, 50, 100 V full scale. Continuously variable mode on all spans and potentiometric operation on six most sensitive spans by removal of internal buss wire. The high sensitivity is obtained by using a single nutster and associated circuitry.

**Accuracy:**  $\pm 0.2\%$  of full scale.

**Linearity:** Terminal Based, 0.1% of full scale.

**Dead band:** 0.1% of full scale.

**Input resistance:** 1-megohm at null on all fixed and variable spans.

**Interference rejection:** dc common mode, 120 dB on three most sensitive ranges; line frequency, 100 dB on three most sensitive ranges.

**Zero-set:** continuously adjustable over full scale, plus one full scale of suppression. Extended 5-scale suppression available at extra cost.

**Maximum source impedance:** up to 10 k ohm source impedance will not alter recorder's performance on the first six ranges (1, 2, 5, 10, 20, 50 mV/fs). Higher source impedances will cause an increase in dead zone and a decrease in pen speed. No source impedance restrictions on ranges above 100 mV/fs.

**Reference supply:** continuous electronic references, zener diode controlled.

**Weight:** 4 lbs net, shipping 7 lbs.

**Price:** Model 17501A \$350

**Option:** 01 With 5-scale zero suppression add \$50

04 Gray control panel n/c

#### Description (17502A)

This temperature measuring input module has a special single span selected to match almost any commonly used thermocouple. A wide variety of ranges are available. Thermocouple reference corrections for changes in ambient temperature are made within the module thus eliminating requirements for a remote compensation junction. The non-linear thermocouple output is converted within the module to a linear function of temperature which allows the use of standard ruled graph paper.

#### Specifications (17502A)

**Voltage spans:** single span to match cold-junction thermocouples.

**Accuracy:**  $\pm 1/2\%$  or  $\pm 1^\circ\text{C}$  (whichever is greater), refer to NBS CIR 561, dtd 1948.

**Input resistance:** potentiometric input.

**Reference supply:** continuous electronic reference, zener diode controlled.

**Interference rejection:** dc common mode, 120 dB; line frequency, 100 dB.

**Weight:** 4 lbs net, shipping 7 lbs.

**Price:** Model 17502A (single span, T-C match) \$250

**Option:** 04 Gray control panel n/c

#### Description (17504A)

This single span plug-in module offers high input resistance and wide versatility. Any single span may be ordered from 5 mV to 100 V full scale. Additional range cards may be ordered for any span within this range. Range cards may be purchased with the desired span and may be recalibrated later, if desired, to any span within the range card limits, (see below). Inputs are floating up to 500 volts above ground, have high common mode rejection, and input impedance of one megohm at null. Removal of jumper wire allows potentiometric input on four most sensitive range cards (5 mV to 200 mV). This modification permits operation with essentially zero current drain at null. Combined with the recorder frame, it offers an unexcelled, versatile, high precision strip-chart recorder.

#### Specifications (17504A)

**Voltage spans:** 10 range cards available, which allow any span from 5 mV to 100 V full scale. Specify range card (part number) or span required when ordering.

**Accuracy:**  $\pm 0.2\%$  of full scale.

**Linearity:** Terminal-Based: 0.1% of full scale.

**Dead band:** 0.1% of full scale.

**Input resistance:** 1 megohm at null. Potentiometric input on first four range cards (5 mV to 200 mV) permits operation with essentially zero current drain at null.

**Interference rejection:** dc common mode 120 dB on 4 most sensitive range cards. AC (line freq.) common mode 100 dB on 4 most sensitive range cards. Combination low pass, line frequency notch filter minimizes differential signal noise effects.

**Zero-set:** continuously adjustable over full scale and one full scale of zero suppression.

**Maximum source impedance:** up to 10 k ohm source impedance will not alter recorder's performance.

**Reference supply:** continuous electronic reference, zener diode controlled.

**Frequency:** 60 Hz (line frequency) 50 Hz operation optional.

**Weight:** 4 lbs net, shipping 7 lbs.

**Price:** Model 17504A (with one range card) \$200

(specify range card)

Additional range cards \$25

**Option:**

01 50 Hz operation n/c

02 Gray control panel n/c



# RECORDERS



## STRIP CHART RECORDERS

For laboratory and industrial use

Models 7127A and 7128A

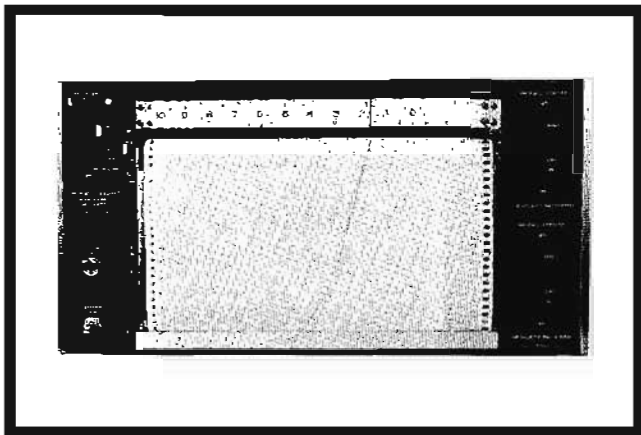

### Description

The Model 7127A/7128A Series 10" strip chart recorders are designed primarily for use with gas chromatograph systems. However, due to the high degree of flexibility, these recorders can be used in a wide range of laboratory and industrial applications. They feature high performance, low cost, and solid state construction for reliability, compactness, and light weight. Model 7128A has two independent servo pen drives and requires two input modules. The 7127A is a single pen unit and takes one input module. Ordering information should specify basic frame and exact input module or modules required.

The Model 17503A input module is designed specifically for use with gas chromatography systems. For other applications the input modules described on the preceding page are compatible with the Models 7127A and 7128A main frames.

Each main frame is equipped with four instantly selected chart speeds and a modular chart magazine. The chart magazine will swing out at a 10° or 30° angle for convenient note writing. An optional integrator for simultaneously and accurately computing the area under the chart curve is also available.

### Description (17503A)

The 17503A plug-in is equipped with special circuitry for gas chromatography use. A single span of one millivolt full scale is provided with potentiometric input. The input can be floated up to 500 V above ground and has high common mode rejection. Zero may be positioned over the full span or suppressed up to one full scale. A high performance input filter allows the recording of signals with differential noise.

### Specifications (7127A/7128A)

**Recording mechanism:** servo activated ink pen drives; manually operated pen lift.

**Response time:** maximum 0.5 sec. (50 Hz operation 0.6 sec.) (Reduce for some input modules.)

**Chart capacity:** 120' chart rolls 11" wide with 10" calibrated writing width.

#### Chart speeds:

Standard 7127A/7128A—1/4, 1/2, 1, 2 inches/min.

H01-7127A & H01-7128A—6, 12, 24, 48 inches/hour.

H02-7127A & H02-7128A—1 1/2, 3, 6, 12 inches/hour.

**Power:** 115 or 230 V ±10%, 60 Hz, 65 volt-amperes for 7128A; 42 volt-amperes for Model 7127A, 115 or 230 V, 50 Hz models available as option.

**Weight:** 7128A, net 30 lbs, shipping 38 lbs 7127A, net 25 lbs, shipping 32 lbs. All weights include input modules.

### Accessories supplied:

- (1) Accessory kit contains: ink cartridge—4 each of red and 4 each of blue, set of Bristol wrenches, balance potentiometer cleaner, syringe and tube for ink system cleaning, extra pen for each channel, rear input mating connector, and pen cleaning wire.
- (2) Appropriate graph paper (one 120' roll).
- (3) Power cord (7').
- (4) Instruction manual.
- (5) Rack mounting brackets.

**Dimensions:** 16 3/4" long, 8-11/16" high, 7 1/4" deep.

**Radio frequency interference:** meets specifications of MIL-I-618D.

**Prices:** (basic frame less input module):

Single Channel	Model 7127A	\$ 850
	H01-7127A	\$ 850
	H02-7127A	\$ 850
Dual Channel	Model 7128A	\$1150
	H01-7128A	\$1150
	H02-7128A	\$1150

### Options:

- |  |           |
|--|-----------|
| 01 With high-low limit switches (7128A and channel one on 7128A):                              | add \$ 50 |
| 02 With remote on-off chart control:   | add \$ 25 |
| 03 For 115 or 230 V, 50 Hz operation:  | n/c       |
| 04 With left moulded event marker:   | add \$ 35 |
| *06 With two event markers:  | add \$ 70 |
| *07 With disc integrator:  | add \$585 |
| 08 Remote controlled electric pen lift:  | add \$ 50 |
| 09 With high-low limit switches (channel two on 7128A):  | add \$ 50 |
| 10 With high-low limit switches (both channels on 7128A):                                      | add \$100 |
| 11 With carrying handle:   | add \$ 25 |
| f12 Mounted in cabinet compatible with F & M chromatograph systems:                            | add \$ 50 |
| f13 With locking glass door:   | add \$ 50 |
| 14 With 5 k ohm retransmitting potentiometer (7127A and channel #1 on 7128A):                  | add \$ 50 |
| *15 With 5 k ohm retransmitting potentiometer (channel #2 7128A):                              | add \$ 50 |
| *16 With 5 k retransmitting potentiometers (channel #1 and #2 7128A):                          | add \$100 |
| 17 Electric writing:   | add \$ 75 |
| 18 Scale marked for use with integrator (integrator not supplied) calibrated writing width 8": | add \$ 15 |
| 20 Scale with "0" right side:  | n/c       |
| 21 Gray control panel:   | n/c       |

### Specifications (17503A)

**Voltage span:** 1 mV full scale (fixed).

**Accuracy:** ±0.2% of full scale

**Linearity:** terminal based: 0.1% of full scale.

**Dead band:** 0.1% of full scale.

**Input resistance:** potentiometric.

**Interference rejection:** dc common mode, 120 dB. Line frequency common mode 100 dB. Contains filter for attenuation of noise and line frequency pickup.

**Zero set:** continuously adjustable over full scale, plus one full scale of zero suppression.

**Maximum source impedance:** up to 5 k ohm source impedance will not alter recorder's performance. Higher source impedance will cause an increase in dead zone and a decrease in pen speed.

**Frequency:** 60 Hz (line frequency) 50 Hz operation optional.

**Price:** Model 17503A, \$250.

#### Options:

- |   |     |
|---|-----|
| 01 Detector selector switch                     | n/c |
| 02 50 Hz operation                              | n/c |
| 03 1 mV (for 8" travel) for use with integrator | n/c |
| 04 Gray control panel                           | n/c |

\*Option 08, 15, 18 cannot be installed when Instrument is equipped with Option 07.

†Only one option (either 12 or 13) can be installed, but not both.

## LOGARITHMIC CONVERTERS

Convert ac or dc signal to logarithmic scale

Models 7560A and 7561A



## RECORDERS

The Models 7560A and 7561A are completely self-contained dual and single channel instruments, respectively. They produce dc output voltages in logarithmic relationship to dc input voltages or the peak or average amplitude of ac input voltages over a 1000 to 1 amplitude range. The output signal of one channel may be applied directly to one axis of an X-Y recorder to produce curves representing logarithmic values as a function of an independent variable applied to the second axis. Since the logarithmic scale compresses the high amplitudes and expands the lower ones, the presentation has the advantage of plotting over wide amplitude ranges with maximum accuracy at low levels. The converter is especially useful working with decibel scales, and when used as a computing element. For log-log plotting, the dual channel converter may be used with one channel for each axis of the recorder.

All functional controls of the 7560A and the 7561A are conveniently located on the front panel. These include input and output attenuators, ac-dc input selector switch, meter and

power switch. Input and output connectors are provided both on the front and rear. Input attenuator steps of 0, 10, 20, 30 and 40 dB permit application of ac signals from 1 mV to 100 volts, and dc from 3.16 mV to 316 volts. The output selector may be set to establish deflections of 5, 10, or 20 dB/inch on the 10 mV/inch range of a standard Moseley X-Y recorder. Metric models (7560AM, 7561AM) are available and provide 2, 5, and 10 dB/cm on the 2 mV/cm range of metric recorders.

The cabinet is attractively designed in a compact module suitable for bench operation with a tilt-bail, and is easily convertible to rack mounting. Completely transistorized including a self-contained power supply, the 7560A and 7561A may be utilized in numerous applications as a systems element.

A typical application is in plotting the frequency characteristics of filters, transformers, amplifiers, networks and similar devices.

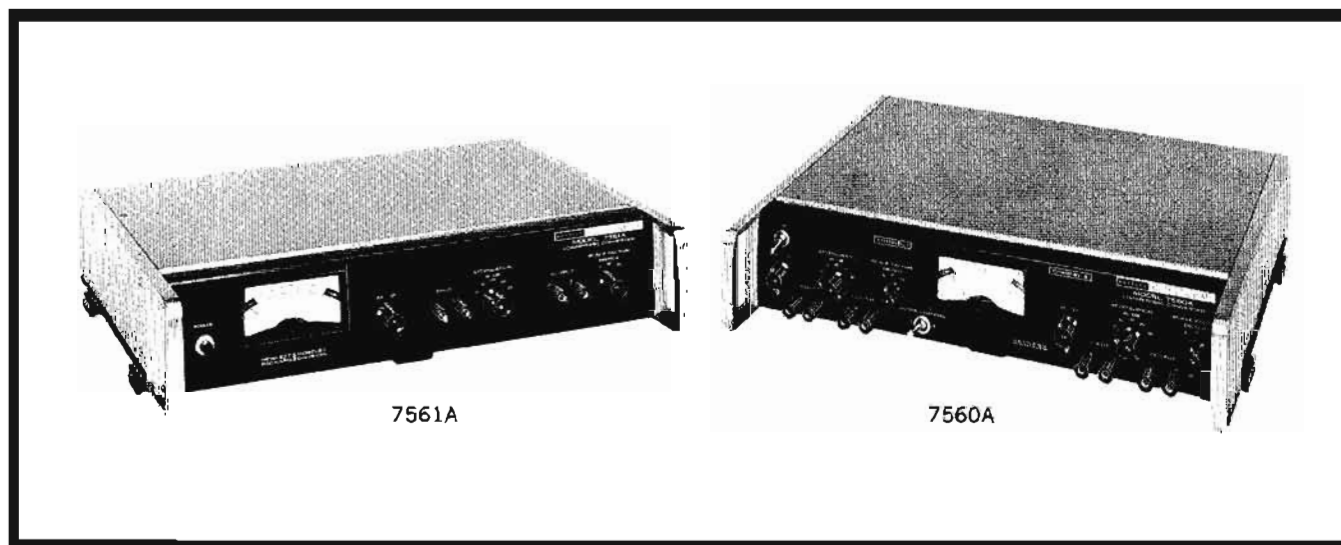

### Specifications

#### Input ranges:

Input Attenuation	AC Input Range (sine wave, RMS)	DC Input Range
0	.001 to 1.0 volt	.00316 to 3.16 volt
-10	.00316 to 3.16	.01 to 10.0
-20	.01 to 10.0	.0316 to 31.6
-30	.0316 to 31.6	.10 to 100.0
-40	.10 to 100.0	.316 to 316.0

**Frequency range:** 20 to 100,000 Hz (ac input).

**Dynamic range:** 60 dB (1000 to 1), ac or dc.

**Output range:** 5, 10, or 20 dB/inch into 20,000 ohm load (10mV/inch recorder range); metric unit: 2, 5, 10 dB/cm into 10,000 ohm load (2 mV/cm range of most metrically scaled recorders).

**Response speed:** up to 1-second for input change of 20 dB.

**Calibration stability:**  $\pm 0.5$  dB (better than  $\pm 0.2$  dB over any 24-hour period).

**Input impedance:** approximately 2 megohms, 35 pF (either ac or dc.)

**Accuracy:**  $\pm 0.5$  dB up to 50 kHz; and  $\pm 1.0$  dB up to 100 kHz; with continuous signal changes less than 2 dB/sec.

**Power:** 115 or 230 V, 50 to 60 Hz, approximately 40 watts on the 7560A, 25 watts on the 7561A.

#### Price:

Dual channel: Model 7560A (standard), \$975.

Model 7560AM (metric), \$975.

Single channel: Model 7561A (standard), \$595.

Model 7561AM (metric), \$595.

# RECORDERS



## ROLL CHART ADAPTERS

Convert recorders for roll chart capability  
Models 17006A/17007A/17008A

Moseley roll chart adapters are designed especially for use with bench type model 2D, 2FA and 7000A Series X-Y recorders. They permit use of 10" x 120' continuous roll chart paper in a variety of operating modes. The roll chart accessories are supplied in a kit for user installation, using pre-tapped mounting holes in compatible recorders.

### Model 17006A

This model permits manual chart advance by operating a hand crank. A crank handle also is provided on the supply reel for rewind purposes. Included is a tear-off wire attachment for chart "pull through, tear off."

### Model 17007A

The 17007A converts compatible recorders to operation as a strip-chart recorder of high accuracy and sensitivity. The 17007A adapter consists of a synchronous motor and gear-train assembly which attaches to the left side of the re-

recorder; eight selectable speeds are provided. Standard speeds furnished are 10, 4, 2, 1 min/in and 30, 15, 5, 2 sec/in. Metrically scaled and calibrated units (17007AM) are available at no extra cost to operate at speeds of 240, 96, 48, 24, 12, 6, 2, 0.8 sec/cm. Both models are available (optional) for operation on 50 cycle current.

### Model 17008A

The 17008A provides compatible recorders with the capability of individual frame positioning of a continuous chart roll. Paper moves from right to left across the recorder platen in 19 inch increments. The advance cycle is initiated by a push-button and is completed in approximately four seconds. Frame positioning is precise with stopping point repeatable within  $\pm 0.01$  inch. During chart advance, the drive unit pulls the paper across the platen, meters it, and stores it on a take-up roller. If desired, single frames may be fed out and separated by tearing against the bottom of the drive unit pressure roller cover.

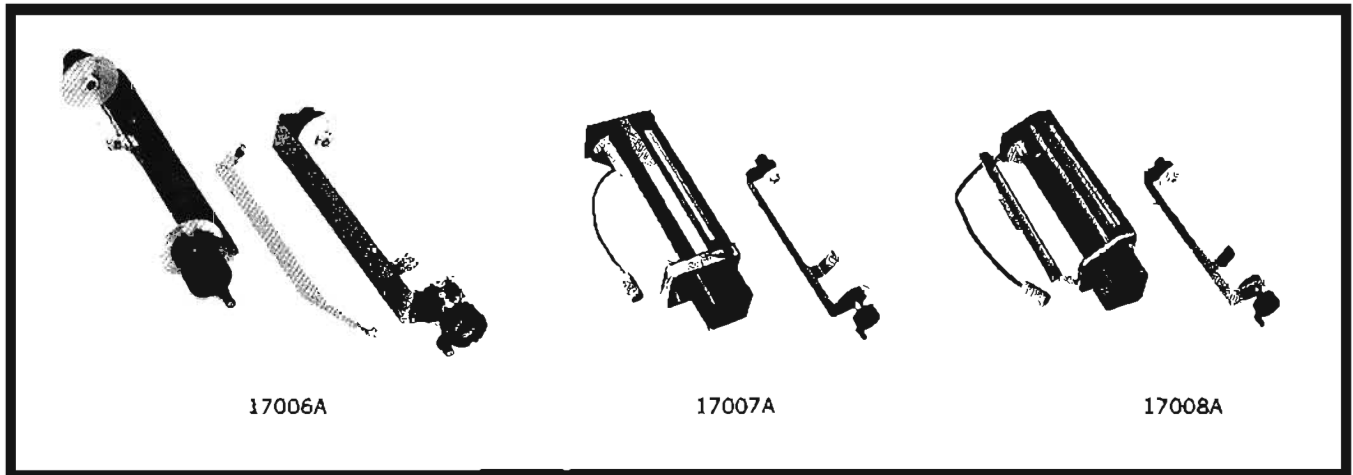

### Specifications

**Compatible recorders:** most bench model 2D, 2FA and 7000A Series Moseley X-Y Recorders.

**Paper requirements:**

- 17007A: Continuous grid roll chart, 10" x 120'.
- 17008A: Frame chart rolls with 10" x 15" frames 4" margin, 120' long.
- 17006A: Any of the above paper.

**Controls:**

- 17006A: None.
- 17007A: On-Off switch, speed selector and "Drive-Stop" lever.
- 17008A: Push-button advance command with provision for remote control.

**Chart speed:**

- 17006A: Manual drive.
- 17007A: A speed selector provides eight speeds: 10, 4, 2, 1 min/in. 30, 15, 5, 2 sec/in. Metric: 240, 96, 48, 24, 12, 6, 2, 0.8 sec/cm.

17008A: Advance cycle of approximately 4 seconds; stopping point of chart repeatable within  $\pm 0.01$  inch (adjustable).

**Power:**

- 17006A: None (manual).
- 17007A: 115 V, 60 cycle, normally supplied from associated recorder which may be operated from either 115 or 230 V (50 cycle operation optional).
- 17008A: 115 V, 50 to 60 cycles, normally supplied from associated recorder which may be operated from either 115 or 230 V.

**Price:**

17006A	\$85
17007A or 17007AM (metric)	\$575
17008A	\$575

**Options: (17007A/AM only)**

*01. Remote control of chart drive	add	\$25
*02. Designed for 50 Hz operation		n/c

\*NOTE: Not compatible with 2D4 recorders.

## RECORDER ACCESSORIES

Accessories for use with x-y recorders



## RECORDERS

### 40D keyboard

The Moseley 40D is a full keyboard-type accessory for use with compatible Moseley x-y recorders to plot tabular data in point-graph form. Operating power is derived from an x-y recorder through a cable and plug connector which also carries servo-positioning information back to the recorder. Keyboard for each axis includes polarity, hold, clear and calibrate keys. Panel selectors control circuits for zero suppression, points/inch calibration and logarithmic plotting.

**Keyboard:** two 3-column, nine-row arrays and unit "1000" keys. Numbers from 0 to  $\pm 1999$  on each axis; function keys provide x hold, y hold, calibrate, clear and main clear.

**Output attenuator (linear mode):** 5 fixed steps at 10, 20, 50, 100, 200 pts/inch (5, 10, 25, 50, 100 pts/cm on metric model); provision for variable attenuation between steps up to 500 pts/inch (200 pts/cm on metric model).

**Accuracy:**  $\pm 0.1\%$ .

**Power:** 115 or 230 V, 50 to 60 Hz, single phase, approximately 12 volt-amperes (derived from associated recorder).

**Dimensions:** 9 $\frac{3}{8}$ " wide, 5-3/16" high, 13-11/16" deep (244 x 132 x 348 mm).

**Weight:** net 16 lbs (7.2 kg); shipping 30 lbs (13.5 kg).

**Price:** Moseley 40D or 40DM (metric), \$975; when ordering for use with existing Moseley x-y recorders, specify model and serial number (compatible recorders must have digital or point plotter receptacles).

### G-2 null detector

The Moseley G-2 Null Detector is an accessory for use with Moseley x-y recorders during point plotting. It controls the operation of the recorder in any one of five modes during plotting of continuous, discontinuous or point function data. The source may be any analog signal producing system, or digital system with conversion accessories. Available in two versions, the G-2A mounts internally as a plug-in unit in Moseley 2D-2 and 2D-3 Recorders; G-2B is a cabinet model with cable and plug for connection to all Model 2D Series (except 2D-4), and existing Models 2A, 2S, and 4S Recorders. For optimum performance, the G-2A should be factory installed.

**Plot rate:** in point mode, 6 plots/sec, max. using 17009A Character Printer; in line mode, 7 pts/sec, max. when points are displaced an average of 0.05 in and using regular recorder pen.

**Sensitivity:** better than 0.4% of full scale.

**Power:** 115 V, 50 to 60 Hz, 1 W single phase.

**Price:** Moseley G-2A or G-2B, \$265; when ordering for existing recorders, specify model and serial numbers; G-2A requires factory installation.

### 17009A/B character printers

The Model 17009A or 17009B Character Printer is an accessory specially designed to replace the pen on most Moseley 11" x 17" x-y recorders to identify points or curves when plotting families of digital information.

The 17009A/B consists of a solenoid assembly with pre-formed flexible cable, connecting plug with cable guide, and six standard character slip-on dies. The solenoid mounts in place of the pen using existing pen swivel mounts; the cable plugs into an existing jack. Symbols are easily and quickly installed or changed by sliding the unit over a fixed flange on the end of the plunger element. Symbols are molded from special porous rubber saturated with a special printing ink. After ten thousand impressions, printing ability of the die may be renewed by a simple impregnation process.

**Plotting rate:** 360 points per minute, maximum.

**Accuracy:** overall recorder accuracy not degraded.

**Power source:** associated recorder.

**Actuating source:** external contact closure, or manually operated pen-lift control of recorder.

**Compatible recorders:** Moseley (most) Models 2D, 2D-2, 2D-3, 7000A series; specify model and serial number.

**Price:** Moseley Model 17009A/17009B, \$95.

**Options:**

01 Extra symbols each, \$1.

### F-3B, 7500A, 7501A, 7502A Line follower systems

The F-3B Line Follower, available factory-installed on Moseley 11" x 17" X-Y Recorders, regenerates original data directly from previously recorded curves. Any line prepared with pencil or pigment-type ink will be followed automatically with high accuracy by means of an optical photo-electric sensing element which replaces the pen of the recorder. The unit does not impair normal recording characteristics of the recorder.

Models 7500A, 7501A and 7502A line follower systems convert Moseley 2D, 680 and 7100B Series Recorders, respectively, for use as chart readers or transport delay simulators.

**Displacement analog output:** F-3B: with external signal supplied—proportional to head displacement. 7500A, 7501A and 7502A: approximately 0 to 6 V dc. or 0 to 5000 ohms

**Straight-line accuracy:**  $\pm 0.03$ " ( $0^\circ$  to  $45^\circ$  and time sweeps through 0.5 sec/in) angular ranges from  $0^\circ$  up to  $85^\circ$  up to 5 sec/in; square waves or spike functions of 0.1 inch maximum amplitude will remain within the scanned area at time sweeps up to 10 sec/in.

**Scanned area:** 0.1 inch on either side of its center line and 0.05 inch along its center line.

**Power:** 115 or 230 volts, 56 to 60 Hz, single phase; F-3B 5 watts, 7500A, 7501A and 7502A; 30-volt amperes.

**Prices:**

Moseley F-3B	\$795
Moseley 7500A (for use with 11" x 17" X-Y Recorders),	\$1595
Moseley 7501A (for use with 680 Series)	\$1650
Moseley 7502A (for use with 7100B and 7127A Series),	\$1650

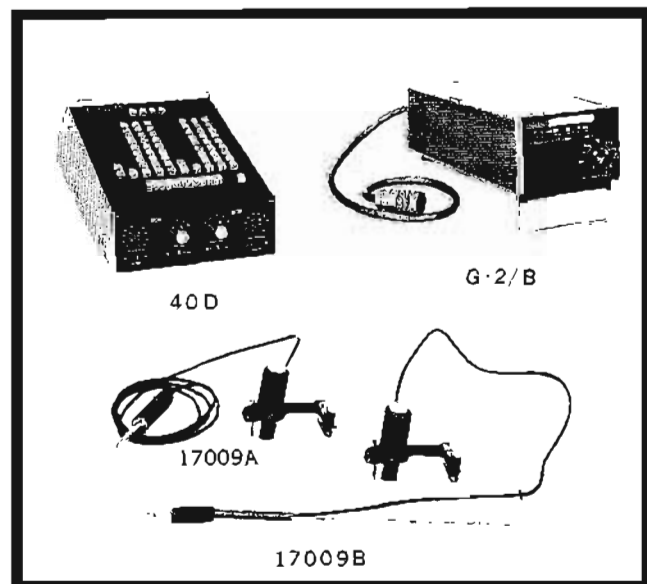



## THERMAL AND INK RECORDERS

Summary of HP systems for permanent, graphic records of measurements

### New! Solid-state ink recording systems

Rectilinear modulated pressure ink recording system with choice of 8 individual-channel "8800 Series" signal conditioners. Readout data appears on 8-channel 600-sheet Z-fold recording chart or 500' roll. Viewing area is 15 $\frac{5}{8}$ " wide and 10" long. Pushbuttons control 14 chart speeds. All operating controls are front panel-mounted. Plug-in ink supply cartridge permits continuous operation. See pages 133-135 for complete information.



8801A



8802A



8803A



8805A

### Thermal writing systems with solid-state plug-ins

Four, 6 or 8 channel oscillographic writing systems with choice of 8 individual-channel "8800 Series" signal conditioners. These include low-gain dc, medium-gain dc, high-gain dc, ac-ac converter, phase sensitive demodulator, carrier, general purpose dc and logarithmic signal conditioners. Systems are complete with power amplifiers, power supplies and your choice of many options. See pages 126-127 for system performance specifications.



8806B



8807A



8808A



8809A

### Identical-channel solid-state systems

These 6, 8 or 16 channel thermal writing systems offer the economical solution to recording many channels of similar measurements. Available in a choice of four 8-channel "950 Series" dc signal conditioners—low gain (50 mV/div), medium-low gain (10 mV/div), medium-gain (0.5 mV/div) and high-gain (10  $\mu$ V/div). Plug-in amplifier elements and subassemblies offer easy accessibility. See pages 127-128 for system performance specifications.



958-3600

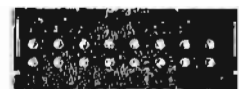

958-3400

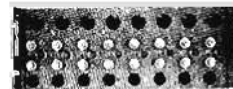

958-2900

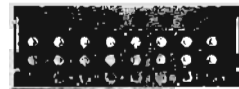

958-1500

### General purpose thermal writing system

A versatile 8-channel system for recording telemetry, computer and other 50 mV to 250 V signals. A wide variety of relatively high-level ac-dc outputs accurately and clearly record data on Permapaper® charts. System is operational after just 4 steps: calibration, setting the range with the attenuator, positioning the stylus and selection of chart speed. System is furnished complete and ready to operate. See page 128 for performance specifications.

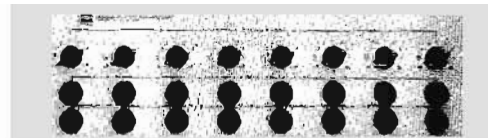

7709-01A



7700-03A

### Portable, mobile systems

For versatile, low-cost 1- and 2-channel recording in the field or in the lab. Chart widths: 32 mm, 50 mm and 100 mm channels.

#### Reliable, general purpose recorders

A "briefcase size" recorder ideal for use by field engineers and test technicians. This 21-pound solid-state recorder occupies less than  $\frac{1}{2}$  cubic foot and operates in any position. Two versions are available—10 mV/div or a universal carrier system. See page 130 for specifications.



#### 100 mm wide chart recorder

With 2 to 3 times the resolution of other units, this recorder accurately displays critical levels of force, velocity, strain, displacement and other measurements. Sanborn "8800 Series" solid-state plug-in preamplifiers provide large-system versatility, but with 100 mm channel width. See page 124 for details.

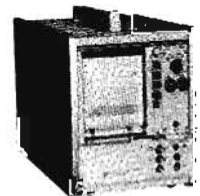

# THERMAL & INK RECORDERS

Summary of HP systems for permanent, graphic records of measurements



## RECORDERS

Series 7858  
with  
8800 Preamplifiers



7858A

Series 7700  
with  
8800 Preamplifiers

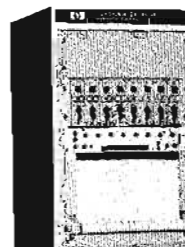

7708A

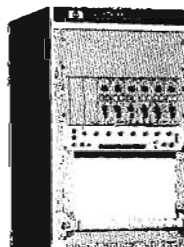

7706B

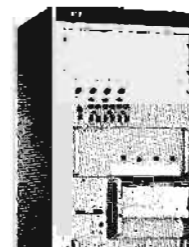

7704A

Series 7700  
with  
950 Preamplifiers

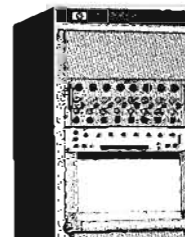

7728A

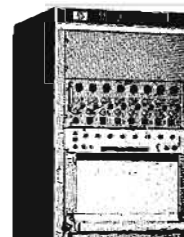

7726A

General purpose  
system

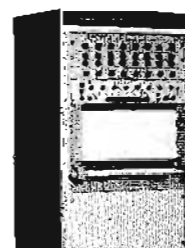

7709A

Portable, rack mount or mobile  
2-channel system

A dual-channel solid-state recorder only 8¾" high with "8800 Series" performance in portable case, rack-mount or mobile cart units. Two 50 mm wide charts display signals clearly with heated stylus writing. Four chart speeds are standard with choice of 4 additional speeds optional. See page 125 for specifications.

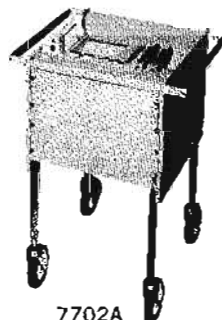

7702A

Portable, 2-channel general  
purpose or carrier recording

Hewlett-Packard offers a choice of 3 lightweight, dual-channel recorders that provide quick, accurate on-the-spot recording. Available in models for general purpose dc-ac inputs in a variety of sensitivities. Two 50 mm channels. See page 131 for specifications.



321

# RECORDERS



## 1-CHANNEL RECORDERS

Wide channel triples resolution

Model 7701A, 7701AX

Model 7701A provides two to three times the signal resolution of a standard width recorder and can be used with any of the versatile solid-state 8800 interchangeable plug-in signal conditioners. Frequency response is dc to less than 3 dB down at 30 Hz for any amplitude between 5 and 50 divisions, damping set for 4% overshoot with a 40 division

p-p square wave. The low-impedance ruggedly constructed galvanometer employs velocity feedback for damping and the power amplifier has electrical limiting to protect recording stylus. Up to 2000 hours of continuous unattended recording at 0.5 mm/min (optional plug-in 1 minute timer) is possible without changing chart roll.

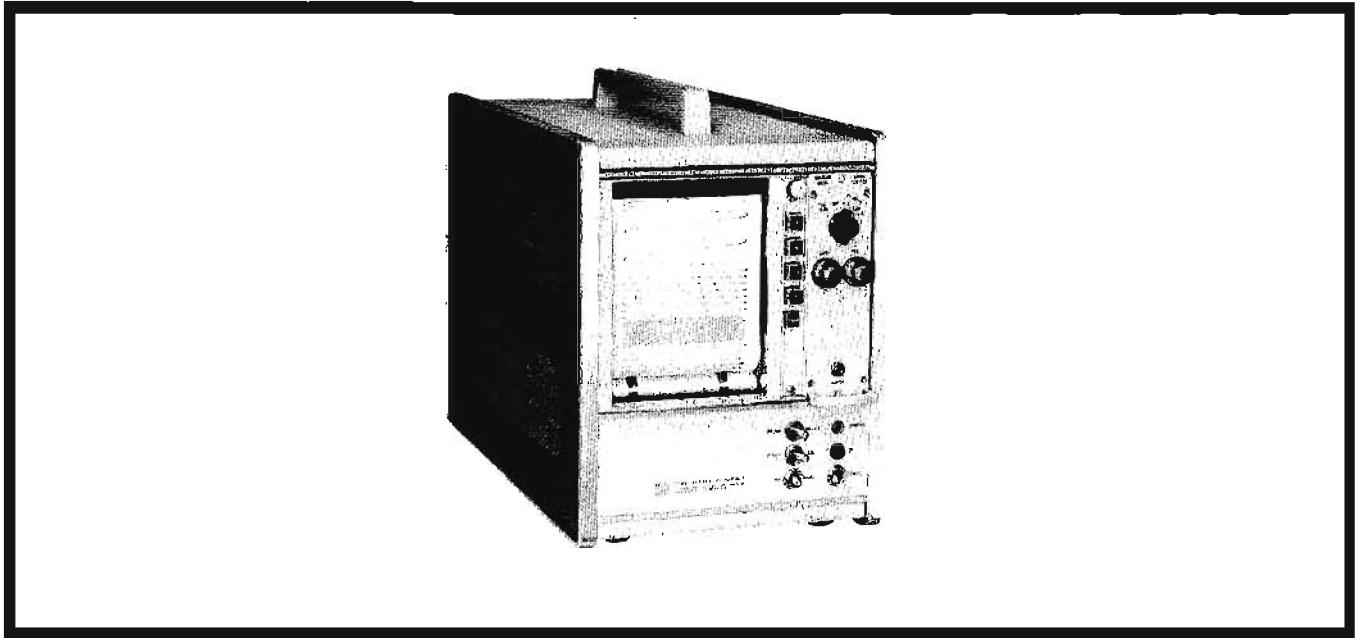

### Specifications

(for complete performance specifications with Sanborn's versatile plug-in 8800 Signal Conditioners see pages 136-141).

**Paper speeds:** 4 mm/sec speed standard (0.5, 2.5, 10 and 50 mm/sec), mechanically shifted and selected by front-panel pushbuttons; four additional speeds 0.5, 2.5, 10 and 50 mm/min can be added as Option 03.

**Event marker:** right margin, manually operated from front panel; 1 sec or 1 min plug-in timer and second event marker optional.

**Front-panel controls:** stylus heat control, pushbutton paper speed selectors, remote-local switch, timer-off-marker switch, mm/sec-mm/min switch, power switch and galvanometer damping adjustment.

**Paper:** 200 ft roll of 100 mm wide-channel standard Permapaper® (651-217); time lines every 5 mm, amplitude lines every 2 mm (50 div full scale).

**Paper take-up:** automatic paper take-up standard (concealed in recorder).

**Power:** 115 volts  $\pm 10\%$ , 60 Hz, 100 watts; 115 or 230 volts  $\pm 10\%$ , 50 Hz, 100 watts (Model 7701AX).

**Dimensions:** 7701A, in carrying case: 13½" high, 10" wide, 18½" deep (343 x 254 x 460 mm); without case: 10½" high, 8-11/16" wide, 17½" deep (269 x 221 x 445 mm); rack mounting adapter (mounts 2 wide-channel recorders): 14" high, 19" wide, 17½" deep (356 x 483 x 445 mm).

**Weight:** 7701A in carrying case, includes typical 8800 Series Preamplifier: net 32 lbs (14,5 kg), shipping 42 lbs (18,9

kg); rack mount adapter: net 20 lbs (9,1 kg), shipping 30 lbs (13,5 kg).

**Accessories:** 1-channel, 100 mm (50 div) 200 ft roll Permapaper (651-217), \$14. (consult local HP sales office for quantity prices); 412-4 Analog Stylus, \$15; 411-9 Marker Stylus, \$9.

**Prices:** Model 7701A Direct Writing Oscillographic Recorder, 115 V, 60 Hz (less preamplifier and case), \$1400; Option 01: Regulator Card, 440 Hz, Model 07701-60110, required when an 8803A Preamplifier is used with the recorder. (With this card, the recorder can be used with any "8800" Preamplifier except Model 8805A), add \$35; Option 02: Regulator Card, 2400 Hz, Model 321-100-C10, required when an 8805A Preamplifier is used with the recorder. (With this card, the recorder can be used with any "8800" Preamplifier except Model 8803A), add \$35; Option 03: mm/minute Speed Reduction Kit (60:1, 60 Hz) Model 07701-60130), add \$110; Option 04: Left Event Marker, Model 07701-60140, add \$45; Option 05: One-Minute Timer (60 Hz unit), Model 07701-60150 available only with Option 03 installed, add \$30; Option 06: One-Second Timer (60 Hz unit), Model 14002E, add \$20; Option 07: Portable Case, Model 7701-04A included, add \$90; Model 7701AX Direct Writing Oscillographic Recorder, 115/230 volts, 50 Hz (less preamplifier and case), \$1450; Option 01: same as 7701A, Option 01.



## DUAL-CHANNEL RECORDER

Mount in cart, cabinet or portable case

Model 7702A



## RECORDERS

This handy Hewlett-Packard dual-channel recorder can be mounted in a cabinet, mobile cart or portable carrying case. It uses the same plug-in preamps as 6- and 8-channel assemblies. The recorder chart paper runs horizontally. Assembly consists of fully solid-state individual current feedback power amplifiers and single power supply. Frequency

response is dc to less than 3 dB down at 125 Hz for chart deflection of 10 divisions p-p. Damping is set for 4% overshoot with a 10 division p-p square wave. Response time is less than 5 msec for 10 to 90% of a 10 division square wave with damping set for 4% overshoot.

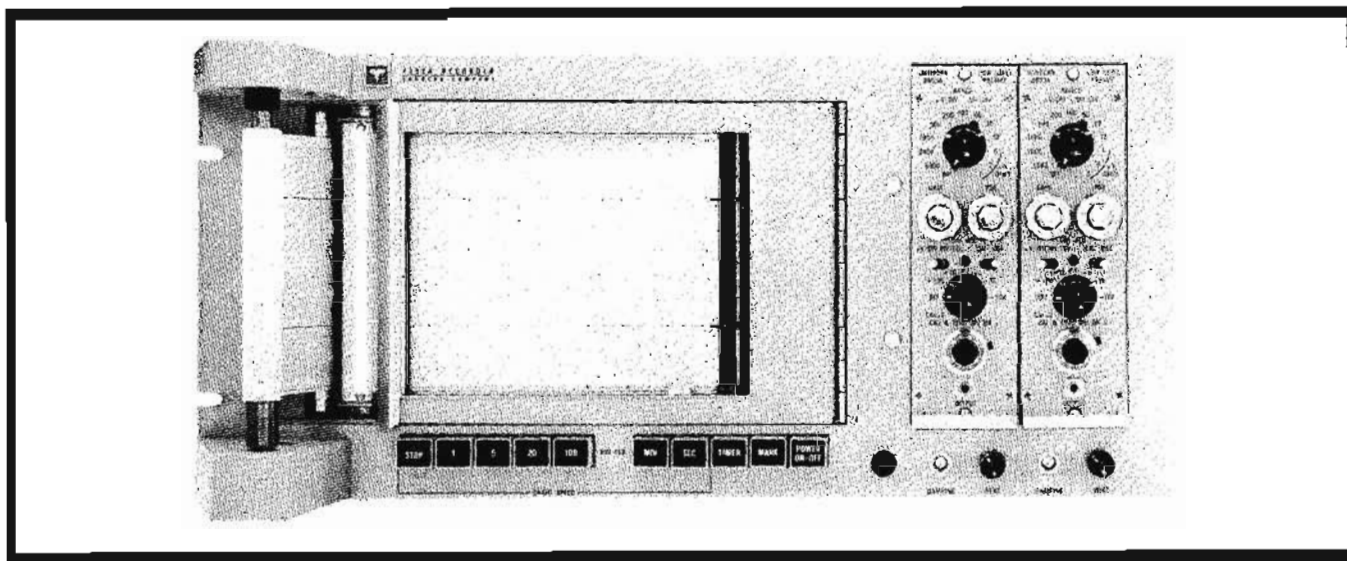

### Specifications

(For complete performance specifications with Hewlett-Packard's versatile plug-in 8800 signal conditioners see pages 136-141.)

**Paper speeds:** standard recorders are supplied with 4-speeds (1, 5, 20 and 100 mm/sec) mechanically shifted and selected by front-panel pushbuttons; other speed combinations are available as options (see Options 10, 11 and 12 under Prices); provision is made for optional remote operation of paper speeds and drive from suitable 115 V ac source.

**Timer-off-marker:** separate stylus marks edge of chart (paper) 1 sec pulses in "time" position (timer motor) or with 60 Hz signal operator can use as a reference mark in "mark" position; remote marking provision at rear connector by simple contact closure (115 V ac); an extra marker is available as optional accessory.

**Panel controls:** individual stylus heat controls; pushbuttons for power, timer, marker and speed selection; and individual galvanometer damping adjustments (screwdriver).

**Paper:** standard 200 ft rolls of 5 inch wide 2-channel Permapaper® (651-52), easily loaded from the recorder panel; one channel only may be used with 1-channel Permapaper (651-51); translucent Permapaper (651-182) is available for making multiple copies of recording on contact copier (Ozolid, etc.).

**Paper take-up:** automatic paper take-up standard equipment.

**Power:** 115 volts  $\pm 10\%$ , 60 Hz, 200 watts; 115 or 230 volts  $\pm 10\%$ , 50 Hz, as Option 08.

**Dimensions:** 7702A, mobile cart: 39 $\frac{1}{4}$ " high, 26 $\frac{3}{4}$ " wide, 20 $\frac{1}{2}$ " deep (997 x 680 x 521 mm); rack mounted Option 01: 8 $\frac{3}{4}$ " high, 19" wide, 17 $\frac{1}{4}$ " deep (222 x 483 x 438 mm); portable case Option 02: 9 $\frac{1}{4}$ " high, 19 $\frac{3}{8}$ " wide, 21 $\frac{1}{2}$ " deep (235 x 498 x 546).

**Weight (approx):** typical for either 7702A with 2 preamplifiers in mobile cart: net, 130 lbs (59 kg); shipping, 172 lbs (77.4 kg); rack mounted Option 01: net, 60 lbs (27.2 kg), shipping, 86 lbs

(38,7 kg); portable case Option 02: net, 89 lbs (40,4 kg), shipping, 135 lbs (60,8 kg).

**Accessories:** 2-channel, 50 mm (50 div) channels 200 ft Permapaper roll (651-52), green coordinates on opaque white paper, \$12.50. 1-channel, 50 mm (50 div) 200 ft Permapaper roll (651-51), green lines on white, \$6.90 (consult local HP sales office for quantity prices); 398 Analog Writing Arm, \$7.15; 411-10 Event Writing Arm, \$6.65 ea.

**Optional accessory equipment:** 462-189 Extra Marker (center margin), \$76. 7702-14A Portable Case (7702-01A recorder) \$195.

**Prices (Note 1):** 7702A (2-channel mobile cart recorder assembly less 8800 Series Preamplifiers), \$1870; mobile cart assembly includes 2-channel recorder, dual-channel power amplifier and power supply, paper take-up and preamplifier power supply.

**Option 01:** same as 2-channel assembly above less mobile cart (includes guide supports for rack mounting): 7702A Option 01 \$1675.

**Option 02:** same as 2-channel assembly above but recorder and preamplifiers are mounted in portable case: 7702A Option 02 \$1870.

**Option 08:** 50 Hz, \$19.20. Option 10: Medical Speeds 2.5, 5, 25 and 50 may be specified with Option 08 and/or Option 11 or 12, no charge. Option 11: mm/minute Speed Reduction (60:1, 60 Hz), add \$150. Option 12: mm/minute Speed Reduction (60:1, 50 Hz), add \$150.

**Note 1:** Add price of signal conditioners (see pages 136-141), times the number of channels you desire to use, to the above basic assemblies prices for complete system cost.

# RECORDERS



## 4-CHANNEL RECORDERS

Pullout table-top facilitates chart noting  
Model 7704A

This Hewlett-Packard recorder provides the convenience of horizontal table-top chart marking, the flexibility and high performance of the solid-state interchangeable, individual-channel preamplifiers (used in 6- and 8-channel assemblies) and the economy of a 4-channel system. Individual power amplifiers have built-in electrical limiting to protect recording stylus and current feedback circuits which virtually eliminate drift. Variables appear sharp and clear, in true rectilinear coordinates on 50 mm wide Permapaper®. Frequency response is dc to less than 3 dB down at 125 Hz for chart deflection of 10 divisions p-p, damping set for 4% overshoot with a 10 division square wave.

### Specifications

(For complete performance specifications with signal conditioners available for these basic assemblies, see pages 136-141.)

**Paper speeds:** 0.25, 0.5, 1, 2.5, 5, 10, 25, 50 and 100 mm/sec.

**Markers:** right side marker is standard; a second marker mounted between channels 1 and 2 is available as an accessory. Amplitude of trace approx. 1.5 mm. With front panel switch or external contact closure in MARK position, marker pulses at line frequency. In TIME position, marker pulses at line frequency for a few cycles every second.

**Front-panel controls:** individual stylus heat controls, speed selector handle motor starting switch, timer-off-marker switch, remote control plug.

**Paper type:** 4-channel green recording Permapaper. Width 10 inches (254 mm), grid 50 mm wide per channel with amplitude lines every 1 mm, 50 divisions full scale, time lines every 1 mm.

**Paper take-up:** front panel loading with front panel concealed paper take-up.

**Paper footage indicator:** indicates paper footage remaining on the supply roll, located on front panel of recorder.

**Power:** 115 volts  $\pm 10\%$ , 60 Hz, approx. 180 watts (less preamplifiers); 115 volts  $\pm 10\%$ , 50 Hz, specify Option 08; 230 volts  $\pm 10\%$ , 50 Hz, specify Option 09.

**Cooling:** cabinet vented top and bottom for convection cooling. Temperature inside of cabinet should not exceed 40°C.

**Dimensions:** 7704A mobile cabinet mount: 72½" high, 22-1/16" wide, 30" deep (1841 x 560 x 762 mm); rack mount Option 01 — 28" high (rack mounting height), 19" wide, 20¾" deep maximum (711 x 483 x 527 mm). Option 02 — consult factory.

**Weight:** (typical) 4-channel recorder with 4 amplifiers in cabinet mount, viz. 7704A: net, 408 lbs (185 kg) less preamplifiers, shipping, 504 lbs (228,2 kg); rack mount Option 01: approx. net, 200 lbs (91 kg), shipping, 275 lbs (124,9 kg).

**Accessories:** 4-channel 5 cm wide channels (50 div), green coordinates, 200 ft. Permapaper roll (651-54-1), \$18.20 (consult local Hewlett-Packard sales office for quantity prices); 4-channel, translucent for contact reproductions, 200 ft. roll (651-184-1), \$29.10 (consult local Hewlett-Packard sales office for quantity prices); 398 Analog Stylus \$7.15; 411-10 Marker Stylus \$6.65.

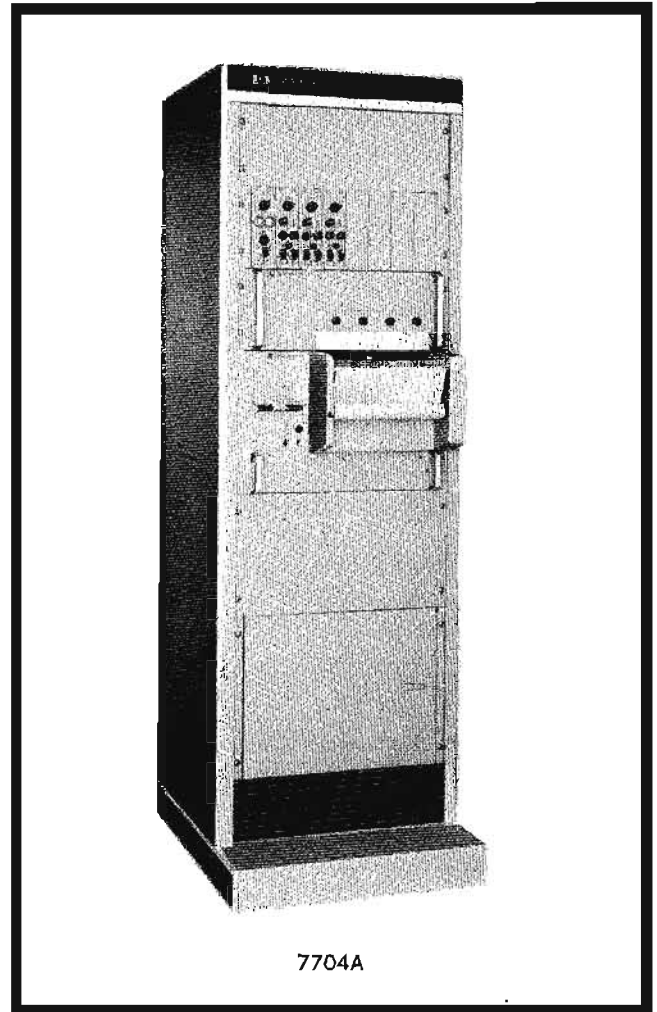

7704A

**Optional accessory equipment:** 608-100-C11 Extra Event Marker, \$70; 188AP DC Marker Driver Amplifier (produces over 1 mm Event Marker deflection with +1.5 volt, 0.5 mA signal input), \$77.50; 188APM DC Marker Driver Amplifier (produces over 1 mm Event Marker deflection with  $\pm 1.5$  volt, 0.5 mA signal input), \$107.50; 7704-09A Mobile System Cabinet, \$500.

**Prices (Note 1):** Sanborn 7704A, 4-channel Thermal Writing System, consisting of cabinet with master power control, power amplifiers and power supply, recorder assembly, pre-amplifier power supply, \$4020.

**Option 01 (Note 1):** less 7704-09A cabinet plus 1069-03A master power panel, \$3645.

**Option 02:** portable cases, consult factory.

**Option 08:** 115 volt, 50 Hz model, add \$50.

**Option 09:** 230 volt, 66A-10 Transformer installed in cabinet or loose (specify), add \$100.

**Note 1:** add price of signal conditioners for each channel required to the above basic assembly price for complete system cost.

## 6- AND 8-CHANNEL SYSTEMS

Record 6 or 8 variables simultaneously  
7700 Series



## RECORDERS

### Advantages:

- Extremely versatile input capacity
- Completely integrated: signal input to galvanometer
- Field-proved electronics, recorder
- True rectilinear inkless recording
- Clear resolution to 4 Hz/mm, 0.25 div non-linearity

### Uses:

- Record 6 or 8 variables simultaneously
- Select the signal conditioners and system packaging best suited to the application

Sanborn 6- and 8-channel basic assemblies offer complete versatility for making accurate, permanent records of multiple variables simultaneously. These basic assemblies accept 6 or 8 channels of interchangeable preamplifiers designed to condition and control simple or complex signals. Variables appear as sharp, clean, permanent traces on Permapaper® charts (opaque, or translucent for copying). They can be analyzed independently, compared immediately with accurate timer pulses, or marked for identification, and stored for later use. Frequency response of the recorder is 0 to 125 Hz on 50 mm wide (6-channel) assemblies; 0 to 150 Hz on 40 mm wide (8-channel) assemblies. Rise time is 4 msec on 8-channel systems, 5 msec on 6-channel. The basic assemblies all use the same flush-front recorder with fully solid-state power amplifiers, which have built-in electrical limiting to protect recorder styli accuracy and feedback circuits to virtually eliminate drift. These systems also can be purchased in optional rack mounts and portable cases.

### Compact all solid-state 8800 Preamplifiers

For Models 7706A, 7708A basic assemblies, the eight channels of 8800 Preamplifiers occupy only 7" x 19" of panel space.

### Economical, all-channels-alike 950 Amplifiers

For Model 7728A (7726A) basic assembly the 950 Series is ideal for applications where many channels of similar real-time or stored data must be monitored simultaneously and there is no need to change individual channels. Four classes of dc 8-channel amplifiers are available in this series (see page 142). Each amplifier channel is complete from signal input to galvanometer output and all channels receive power from a single power supply.

### General-purpose system

With the 7709A, many channels of telemetry and computer outputs as well as a wide variety of relatively high level ac-dc outputs can be accurately and vividly displayed. This general-purpose recorder provides the versatility, simplicity and reliability required in multi-channel recording systems. Operation is simple—only four steps are required for operation once the system is turned on: (1) calibrate (internal

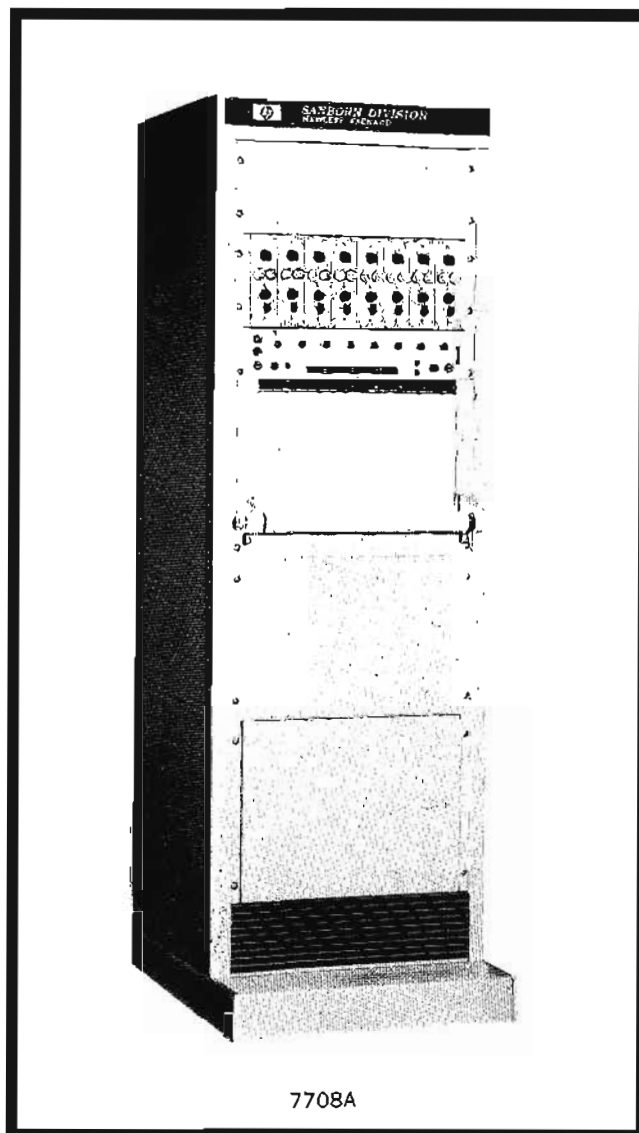

source provided), (2) set input range with the attenuator, (3) position the stylus, and (4) select the chart speed. An event channel is supplied for the recording of timing or coded pulses. Input polarity for each channel may be changed by turning a switch.

### Specifications (all models)

(The complete system performance specifications of these basic assemblies with the two classes of preamplifiers (amplifier) are on Pages 136-142.)

**Paper speeds:** standard recorders are supplied with 9 speeds: 0.25, 0.5, 1, 2.5, 5, 10, 25, 50 and 100 mm/sec, electrically shifted and selected by front-panel pushbuttons; optional "D" version recorders have 9 additional speeds, 0.25, 0.5, 1, 2.5, 5, 10, 25, 50 and 100 mm/min; provision is made for optional remote operation of paper speeds and paper drive.

**Event marker:** right margin; built-in timer provides 1 sec timing marks; provision for manual or remote event marking from external contact closure; "D" version recorders provide 1 sec and 1 min timing markers; optional second event marker (608-100-C11) can be installed between channels #1 and #2 and actuated by external contacts; also, solid-state marker driver amplifiers for dc event marking are available (188AP, +dc input and 188APM,  $\pm$ dc input) and require 1.5 V at 0.5 mA at input to produce slightly over 1 mm deflection.

**Front-panel controls:** individual stylus heat controls; push-button speed selectors; motor starting switch; timer-off-marker switch.

**Paper footage indicator:** front-panel indicator shows number of feet remaining on the supply roll.

**Paper length:** standard roll 200 feet long; adapter (462-184) allows the use of special 1000 foot rolls: adapter requires  $8\frac{3}{4}$ " (222 mm) of panel space.

**Paper takeup:** standard paper takeup on front panel; concealed takeup (358-800) is available on special order and occupies additional  $8\frac{3}{4}$ " (222 mm) of panel space.

**Power:** recorder: 115 volts  $\pm 10\%$ , 60 Hz, 230 watts; 115 or 230 volts, 50 Hz available on special order; systems: 7708A, 390 watts; 7728A, 515 watts.

#### Dimensions

**7706A, 7708A:** mobile cabinet mount:  $72\frac{1}{2}$ " high,  $22\frac{1}{16}$ " wide, 30" deep (1841 x 561 x 762 mm); rack mount Option 01: (recorder)  $17\frac{1}{2}$ " high, 19" wide,  $24\frac{1}{8}$ " deep (445 x 483 x 613 mm); (amplifier) 7" high, 19" wide,  $20\frac{1}{2}$ " deep (178 x 483 x 621 mm); portable cases Option 02: (recorder)  $19\frac{3}{4}$ " high, 20" wide,  $21\frac{1}{2}$ " deep (502 x 508 x 546 mm); (amplifier)  $7\text{-}9\frac{1}{16}$ " high, 22" wide,  $21\frac{1}{2}$ " deep (193 x 559 x 546 mm).

**7728A:** mobile cabinet mount: same as 7706A, 7708A; rack mount Option 01: (recorder) same as 7708A; (amplifier) 7" high, 19" wide, 18" deep (178 x 483 x 457 mm).

**7709A:** mobile cabinet mount same as 7706A, 7708A; rack mount Option 01: (recorder) same as 7708A; (control panel and recorder occupy  $26\frac{1}{4}$ " of panel space).

**Weight, typical (for all systems in cabinet):** 8-channel recorder with 8 amplifiers in cabinet mount, viz. 7708A: net 590 lbs (265,5 kg), shipping 755 lbs (339,8 kg); rack mount Option 01: recorder, all systems: net 210 lbs (94,5 kg), shipping 250 lbs (112,5 kg); 8800 Preamplifiers (8): net 100 lbs (45 kg), shipping 120 lbs (54 kg), subtract 12 lbs (5,4 kg) for 6-channels; 950 Amplifier, viz. 7728A: net 85 lbs (38,3 kg), shipping 95 lbs (42,8 kg); 950 Amplifier, viz. 7726A: no change for 6 channels; portable cases Option 02: recorder, all systems: net 300 lbs (125 kg), shipping 340 lbs (153 kg); 8800, 950 Amplifiers viz. 7708A, 7728A: net 120 lbs (54 kg),

shipping 140 lbs (63 kg). Control panel and polarity reverse panel, viz. 7709A: net 23 lbs (10,3 kg), shipping 32 lbs (14,4 kg).

**Accessories:** 8-channel, 40 mm (50 div), 200 ft Permapaper® roll 651-58, \$23.50; 6-channel, 50 mm (50 div) 651-57, \$21.80 (consult HP sales office for 1000 ft rolls and price for quantity purchases of 200 ft rolls); 399 Analog Writing Arm (8-channel), \$6.65; 398 Analog Writing Arm (6-channel) \$7.15; 411-3 Marker Arms (8-channel), \$6.65; 401-10 Marker Arms (6-channel), \$6.65.

**Optional accessory equipment:** 358-800-1 Concealed Paper Take-up, \$350; 462-184 1000 ft Roll Adapter, \$175; 608-100-C11 Extra Event Marker, \$70; 188AP Marker Driver Amplifier (+1.5 V dc input), \$77.50; 188APM Marker Driver Amplifier ( $\pm 1.5$  V dc input), \$107.50; 358-1400 Recorder Carrying Case, \$250; 858-1400 (7706A, 7708A, 7728A) Amplifier Carrying Case, \$250.

**Prices (Note 1):** Model 7706A (6-channel cabinet assembly, less 8800 Amplifiers), \$4820; Model 7708A (8-channel cabinet assembly, less 8800 Amplifiers), \$5495; cabinet consists of master control panel, blower system preamplifier rack(s), recorder assembly with power amplifiers and power supply, and preamplifier power supplies; Model 7728A (8-channel cabinet assembly, less 950 Amplifiers), \$3425; cabinet assembly consists of master control panel and cabling, blower system, transfer chassis and 8-channel recorder; Model 7726A is quoted on request. Model 7709A 8-channel system consists of cabinet, control panel, polarity reversal panel, recorder assembly including an 8-channel recorder, power amplifier power supply and 8 power amplifiers: \$5030.

**Option 01 (Note 1) all models:** (same as 6- or 8-channel assemblies less cabinet includes: blower, master power panel cabling and slides for rack mounting): Model 7706A Option 01, \$4425; Model 7708A Option 01, \$5100; Model 7728A Option 01, \$3000; 950 Amplifiers used with this recording system under Option 01 have a muffin fan installed on the rear for cooling purposes; when ordering, add a -3 after the amplifier model number, and add \$100 to the price of the 950 Amplifiers; also add  $1\frac{5}{8}$ " to the depth dimension of the amplifier. Model 7709A Option 01, \$4650. (less cabinet).

**Option 02 (Note 1) all models:** Model 7706A Option 02, \$4820; Model 7708A Option 02, \$5495; Model 7728A Option 02 (consult factory), (recorder and amplifier assemblies supplied in portable cases). Model 7709A Option 02, \$5030 (recorder and control panel/polarity reversing panel assemblies supplied in portable cases). Model 7709A Option 03, add \$150 (polarity reversing panel).

**Note 1:** Add price (times number of channels) of signal conditioners required to the above basic assembly prices for complete system cost. "D" version recorders have 9 mm/min, in addition to standard 9 mm/sec speeds; adds \$250 to system cost; order by requesting "D" recorder.

## RECORDERS

Recording systems for lab, bench or field  
Models 7701A, 7702A



## RECORDERS

### Features

- Choice of 8 versatile plug-in preamplifiers
- 4 speeds, 8 optional
- Ideal for the recording of low-level signals from thermocouples, strain gages, differential transformers
- Heated styli, true rectilinear recording
- Solid-state throughout

### 7701A, 100-mm wide-chart, single-channel recorder

Model 7701A is a lightweight instrument that offers improved readability by means of 100-mm wide rectangular coordinate recording charts and the versatility of "8800" Series interchangeable plug-in preamplifiers. This recorder provides maximum efficiency because all recording functions are controlled at the front panel. Preamplifiers available for this recorder are all solid-state. Preamplifier power supply has provision for a plug-in oscillator card which eliminates the need for external carrier or chopper excitation. The size and weight of this instrument make it convenient for test bench instrument operation, field operation or rack mounting for systems use. Dual-channel wide-chart recording can

be easily accomplished by fitting two Model 7710A's side-by-side in a standard 19-inch rack. Eight 7701A's can be accommodated in a standard upright cabinet. Complete descriptions, specifications and prices are found on page 122.

### 7702A, dual-channel recorder

Two 50-mm charts for rectangular coordinate recording of measurements and comparisons. The 7702A uses "8800" Series preamplifiers which are interchangeable and plug in directly into the front panel. This compact system occupies a mere 8 $\frac{3}{4}$ " of panel height and can be rack-mounted in an equipment cabinet, an easy-to-handle mobile cart or in a handy carrying case for field applications. The two-channel recording section uses the same low-impedance, velocity-feedback-damped galvanometers which are found in the larger recorders. The recording paper is easily loaded and may be driven at any one of four speeds. These are push-button-controlled. Approximately 6 inches of visible record is available for viewing and marking while recording. Additionally, the recording section provides a separate margin stylus for marking and timing. Timing is provided by an internal timer which produces a pulse every second on the chart. Complete descriptions, specifications and prices appear on page 123.

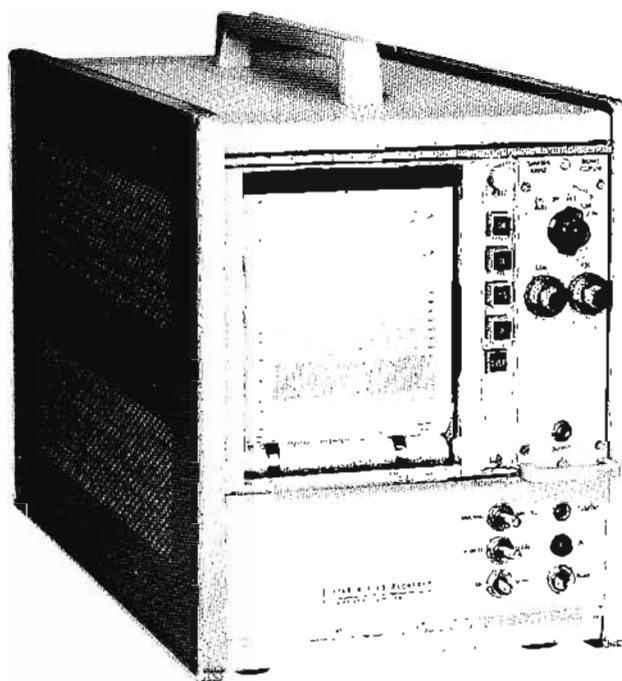

7701A

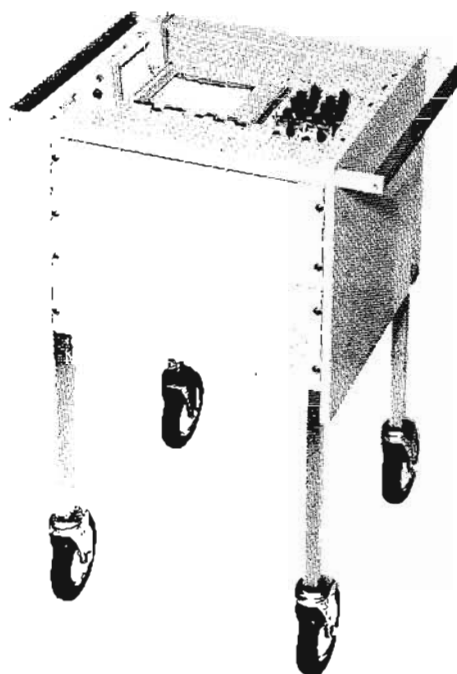

7702A

# RECORDERS



## 1-CHANNEL PORTABLES

For medium-gain dc/ac or carrier measurements  
Models 299, 301

These single-channel, 25 lb recorders are widely used by engineers and technicians for measuring and recording the results of equipment checkout and servicing, in the field and in the laboratory. They possess most of the features found in larger systems and produce high resolution traces on a 32 mm (40 div) wide channel. Four inches of chart

are displayed at all times for study and marking. Model 299 is very useful for medium-gain broad dc and ac measurements; 301 (with built-in excitation source) for carrier inputs from resistance bridges, variable reluctance devices, differential transformers and other ac transducers.

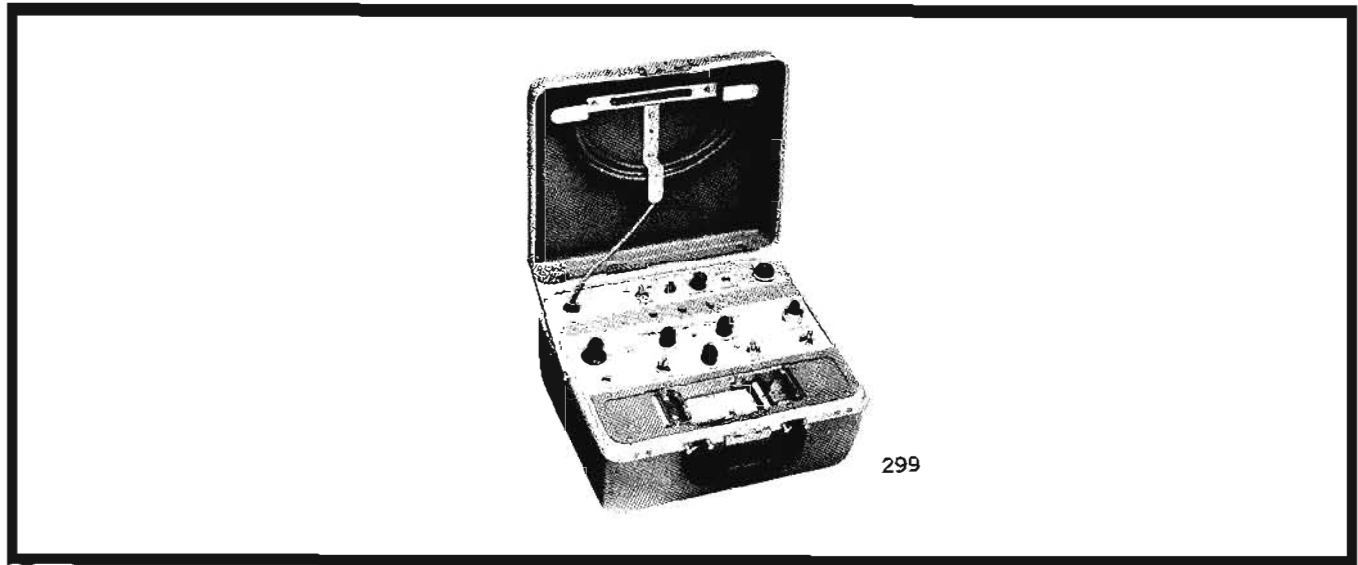

### Specifications

Recorder model	Sanborn 298	Sanborn 301 †
Sensitivity (maximum)	10 mV rms/div (each div = 1/32")	10 $\mu$ V rms/div (each div = 1/32")
Sensitivity range (attenuation)	10, 20, 50, 100, 200, 500 mV/div and 1, 2, 5 and 10 V/div; attenuator error $\approx$ 2% max.	X1, 2, 5, 10, 20, 50, 100 and 200 attenuation factors; attenuator error $\approx$ 2% max.
Input circuit	5 megohms each side, balanced to ground	6000 ohms min. resistance, 13 K min. reactance—measured with full zero suppression and R & C balance; 7000 ohms resistance, 13 K reactance—with R & C balance control centered and zero suppression out; transducer impedance, 100 ohms min.
Common mode or quadrature rejection ratio	50:1 on most sensitive ranges; 25:1 on other ranges	quadrature rejection ratio is greater than 100 to 1
Common mode or quadrature voltage tolerance	$\approx$ 2.5 V max. on most sensitive range, higher on other ranges to $\approx$ 500 V max. 10X the differential signal which causes 25 div deflection up to 500 V max.	quadrature tolerance: quadrature rejection is in specification if input signal amplitude does not exceed 2X that of an inphase signal which causes stylus deflection from chart center to chart edge with zero suppression off.
Zero suppression	$\approx$ 2 V max., from mercury cells, in series with output of input attenuator, and used for both single-ended and balanced inputs; corresponds to max. suppression of 10 times center of chart to either edge	5-step switch, center out, two positions for both positive and negative signal, each step equivalent to approx. 5 turns of R-Bal control
Frequency response (-3 dB max. at 10 div p-p) (-3 dB max. at full scale)	dc to 100 Hz dc to 50 Hz	dc to 100 Hz dc to 50 Hz
Zero drift Temperature, 0 to 50°C Line voltage variation, —103 to 127 volts Time	0.5 div/10°C 0.25 div 0.5 div/hr, 2 div/24 hrs	0.25 div/10°C 0.1 div
Noise (peak-to-peak max.)	0.1 div	0.25 div
Calibration (internal)	0.2 V, $\approx$ 1%	40 $\mu$ V/excitation volt, $\approx$ 1% (200 $\mu$ V/20 div deflection)

†Carrier frequency 2400 Hz, internally supplied; carrier voltage 4.5 to 5.5 V rms, not adjustable.

## 2-CHANNEL PORTABLES

For recording both dc or carrier variables  
Models 320, 321, 322



## RECORDERS

These complete recording systems are extremely useful in the field when two similar variables must be simultaneously analyzed and permanently recorded. They operate in any position, record signals on two 50-mm wide channels, have electrical limiting to protect recording styli and current feedback circuits to reduce drift. Model 320 has guarded and floating inputs designed for broad dc and ac signals even though complicated by excessive noise due to ground loops. Model 322 has two general-purpose direct-coupled amplifier channels, each with calibrated zero suppression, which can be used for single-ended and balanced inputs. Model 321, with built-in 2400 Hz carrier excitation source, is designed to measure signals from resistance bridges, variable reluctance devices, differential transformers and other ac transducers.

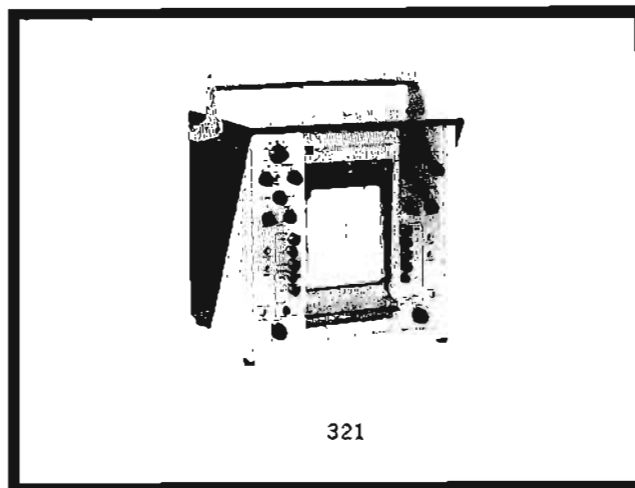

### Specifications, dual-channel

Recorder model	Sanborn 320	Sanborn 321†	Sanborn 322, 322A
Maximum sensitivity	0.5 mV/div (each div — 1 mm)	10 $\mu$ V/div (each div — 1 mm)	10 mV/div (each div — 1 mm)
Attenuation range	0.5, 1, 2, 5, 10, 20 mV/div and V/10 div; attenuator error $\pm$ 2% max.	X1, 2, 5, 10, 20, 50, 100 and 200 attenuation factors; attenuator error $\pm$ 2% max.	10, 20, 50, 100, 200, 500 mV/div and 1, 2, 5 and 10 V/div; attenuator error $\pm$ 2% max.
Input circuit	0.5 megohm on mV/div and 1 megohm on V/10 div; floating and guarded with channel-to-channel isolation; dc source resistance should be below 10 K on mV ranges only	6000 ohms min. resistance, 13 K min. reactance, measured with full zero suppression and R & C balance; 7000 ohms resistance, 13 K reactance, with R & C balance control centered and zero suppression out; transducer impedance, 100 ohms min.	5 megohms each side balanced to ground
Common mode or quadrature rejection ratio	140 dB max. at dc; 120 dB min. at 60 Hz with no input unbalance; 100 dB min. at 60 Hz with 5000 ohms unbalance	Quadrature rejection ratio is greater than 100 to 1	50:1 on most sensitive range, 25:1 on other ranges
Common mode or quadrature voltage tolerance	$\pm$ 500 volts max.	Quadrature tolerance: Quadrature rejection is in specification if input signal amplitude does not exceed 2X that of an inphase signal which causes stylus deflection from chart center to chart edge with zero suppression off.	$\pm$ 2.5 volts max. on most sensitive ranges; higher on other attenuator positions to $\pm$ 500 volts max.
Zero suppression	None	5-step switch, center out, two positions for both positive and negative signal, each step equivalent to approx. five turns of R-Bal controls	$\pm$ 2.5 V max. from mercury cells, in series with output of input attenuator, and used for single-ended and balanced inputs; corresponds to max. suppression of ten times center of chart to either edge (322A has no zero suppression)
Frequency response (—3 dB max. at 10 div p-p)	dc to 125 Hz	dc to 125 Hz	dc to 125 Hz
(—3 dB max. at full scale)	dc to 50 Hz	dc to 50 Hz	dc to 50 Hz
Zero drift Temp., 0 to 50°C;	0.25 div/10°C	0.25 div/10°C	0.5 div/10°C
Line voltage variation, 103 to 127 V	0.1 div	0.1 div	0.25 div
Time	—	—	0.5 div/hr, 2 div/24 hrs
Noise (p-p max.)	0.25 div	0.25 div	0.1 div
Internal calibration	10 mV, $\pm$ 2%	40 $\mu$ V/excitation volt, $\pm$ 1% (200 $\mu$ V 20 div deflection)	0.2 volt $\pm$ 1%

†Carrier frequency 2400 Hz, internally supplied; carrier voltage 4.5 to 5.5 V rms, not adjustable.



### Specifications (1, 2-channel portables)

**Gain stability:** better than 1% to 50°C on all models; better than 1% for line voltage variations from 103 to 127 V ac, all models.

**Non-linearity:** 0.25 div max with respect to straight line through centerline and calibration point 20 div from chart center, all models.

**Response time:** 5 msec, 10% to 90% with 4% or less overshoot over center ten divisions.

**Paper speeds:** single-channel 299,301: two speeds (5 and 50 mm/sec); dual-channel 320, 321, 322: four speeds (1, 5, 20 and 100 mm/sec); other speeds are available on any model on special order.

**Channel width:** single-channel models, 1.25" divided into 40 div, 1/32" apart; dual-channel models, 2" divided into 50 div, 1 mm apart.

**Timer-marker:** single-channel models have separate stylus for edge marking (60 Hz excitation); on dual-channel models, 1 second timers are internal and extra event marker can be added on special order; jacks are provided on all models for remote operation of marker coil by contact closure.

**Input connectors:** single-channel, 3-pin contact male connector on front panel; dual-channel models in portable cases have 3-pin contact male front-panel connectors, rear connectors when rack mounted (optional binding post adapters available).

**Monitor output connectors:** miniature phone jack on front panels provide approx. 40 mV div across min. external load of 100 k.

**Electrical limiting:** single-channel, approx. 125% of full scale; dual-channel, approx. 115% of full scale.

**Power requirements:** single-channel, 115 volts  $\pm 10\%$  60 Hz, 45 watts; dual-channel, 115 volts  $\pm 10\%$  60 Hz, 100 watts; 115-230 volts 50 Hz available in all models on special order.

**Dimensions:** single-channel models: 7" high, 12" wide, 10½" deep (178 x 305 x 267 mm); dual-channel models in portable cases: 13¾" high, 14¼" wide, 9½" deep (349 x 361 x 241 mm); rack mounts (models ending in R): 14" high, 19"

wide, 16" deep (356 x 483 x 406 mm); paper takeup 320-300 for dual-channel portable is 4¾" high, 14½" wide, 9½" deep (121 x 370 x 241 mm) and 320R-300 on rack mount adds only 5¼" (133 mm) to recorder height.

**Weight, approx:** single-channel models: net 22 lbs (10 kg), shipping 25 lbs (11,3 kg); dual-channel models: net 55 lbs (24 kg), shipping 66 lbs (29,7 kg).

**Accessories:** 1-channel: Permapaper®, 1¼" wide (40 div), 125 ft roll (651-202-1), \$4.60 ea (consult Hewlett-Packard sales office for quantity prices); 403A Analog Writing Stylus, \$6.65; 411-1 Marker Stylus, \$6.65; dual-channel: Permapaper (651-52-1) 50 mm (50 div), 200 ft roll, \$12.50; 398 Analog Writing Stylus, \$7.15; 411-10 Marker Stylus, \$6.65.

**Optional accessory equipment:** paper takeup 299-300 for single-channel 299, 301, \$41; paper takeup 320-300 for dual-channel 320, 321, 322 (in portable cases) \$150; 320R-300 for dual-channel 320R, 321R, 322R (rack mounts), \$175; binding post adapter (to make it easier to connect banana plugs, spade lugs, clip leads, bare wires, etc.): 299-200-C10 for 299 and 322, \$10; 301-200-C11 for 301, \$9; 320-100-C31 for 320 and 321, \$11 extra marker 462-189 (center-margin) for dual-channel models, \$76.

**Prices:** single-channel: Model 299, \$800; Model 301, \$850; dual-channel: portable case: Model 320, \$1650; Model 321, \$1650; Model 322, \$1395; Model 322A (without zero suppression) \$1295; rack mount: Model 320R, \$1800; Model 321R, \$1800; Model 322R, \$1545; Model 322AR, \$1445.

### Model 53 Battery Converter

This handy accessory is a portable, stable source of ac power that will operate single- and dual-channel recorders in most field applications. It will supply 128 volts, 60 Hz at 125 watts continuously for 2 hours, and with a 35 watt load, battery life between charges is 7 hours. Model 53 is a combination charger/converter/storage battery packed in a flameproof carrying case 9" high, 14" wide, 5" deep (246 x 372 x 137 mm). Weight 30 lbs (6,7 kg). Model 53 (including 12-volt storage battery), \$271; without battery, \$225.

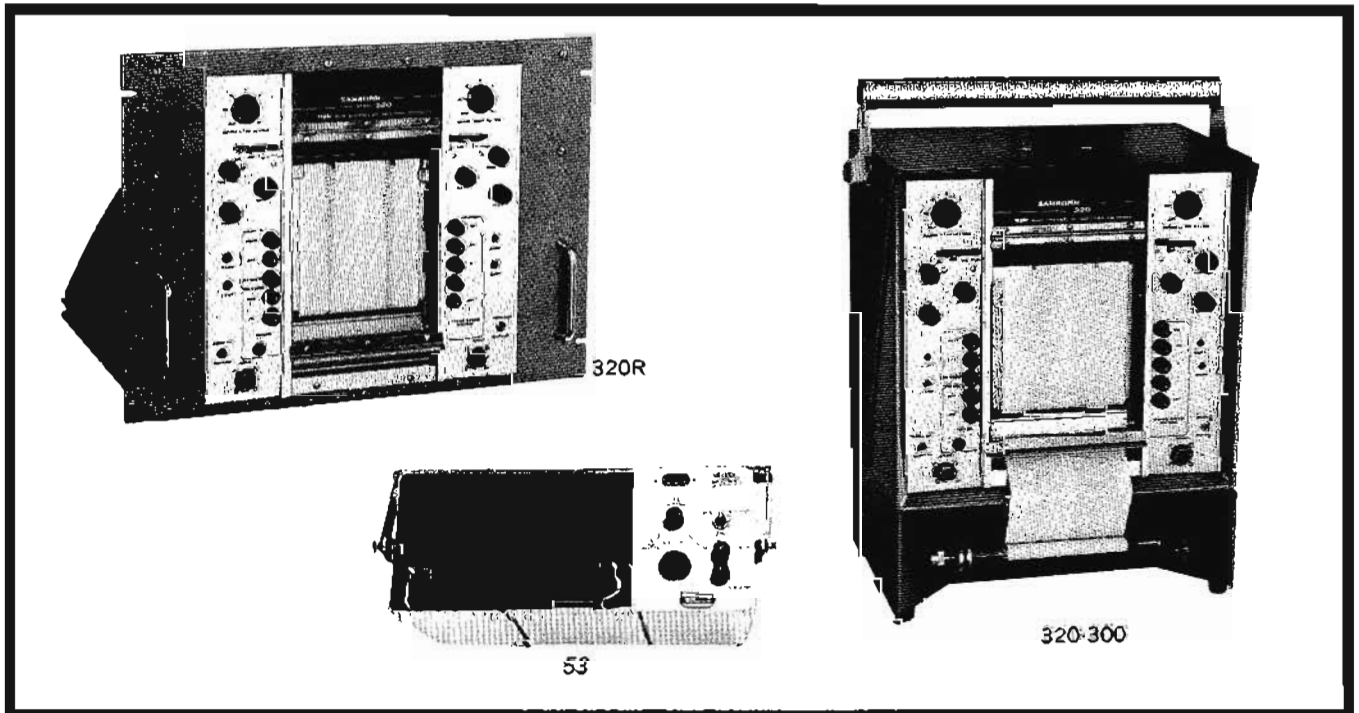

## RECTILINEAR INK RECORDER

New ink system records on Z-fold paper or rolls  
Model 7858A



# RECORDERS

### Features:

- Reliable, inexpensive, non-smear, non-splatter, non-clog rectilinear writing
- Sharp, high-resolution, consistent traces from dc to 160 Hz
- Easily reproducible recording by inexpensive means
- Eight plug-in solid state signal conditioners to choose from
- Numbered Z-fold chart for convenient access to entire record

### Uses:

- Accurate, permanent recording of up to 8 variables from a wide range of inputs

Model 7858A is an integrated, 8-channel rectilinear ink recording system designed to deliver greater accuracy than present-day recorders. The recorder has a self-contained power supply and modular type solid-state electronics. The chart viewing area is  $15\frac{5}{8}$ " wide with a length of ten inches. Its low-pressure ink system produces ultra-clear traces throughout the recorder's electrically-controlled speed range — from .025 to 200 millimeters per second. The paper chart moves from top to bottom from an internal supply and take-up roll or from an internal Z-fold paper supply. A wide selection of "8800" Series Preamplifiers provides signal conditioning to the driver-amplifiers which drive the recording pens of the multi-channel recorder. The system includes preamplifier power supply, a driver amplifier power supply and a cabinet to house the complete system. Front panel pushbuttons assure ease of operation. The frequency response of the recorder is 160 Hz for 10 div p-p deflection and 60 Hertz maximum for full scale deflection. Maximum ac or dc non-linearity is 0.5% full scale.

### System components

The 7858A system consists of the the following major components: "8800" Series Preamplifiers, as ordered; 7858-01A 8-channel position feedback ink recorder; 8800-03A Preamplifier Power Supply and 7858-09A Cabinet. System Option 01 for rack mounting omits the cabinet and adds 1069-03A Master Power Panel; Option 02 omits the cabinet and adds 358-1400 Recorder Carrying Case and 858-1400 Amplifier Carrying Case.

### System characteristics

The following specifications apply to the entire system. For specifications which depend upon choice of preamplifier, see pages 136-141.

**System power:** 115 volts  $\pm 10\%$ , 60 Hertz, 600 watts. Other voltages and frequencies on special order.

**Size:** 72" high, 22" wide, 30" deep (1830 x 534 x 762 mm). Option 01 uses only 24 $\frac{1}{2}$ " (632 mm) panel height. Option 02 uses Recorder Carrying Case 20" high, 19 $\frac{3}{4}$ " wide, 21 $\frac{1}{2}$ " deep (508 x 502 x 546), plus Amplifier Carrying Case 22", high, 7-9/16" wide, 21 $\frac{1}{2}$ " deep (762 x 195 x 546).

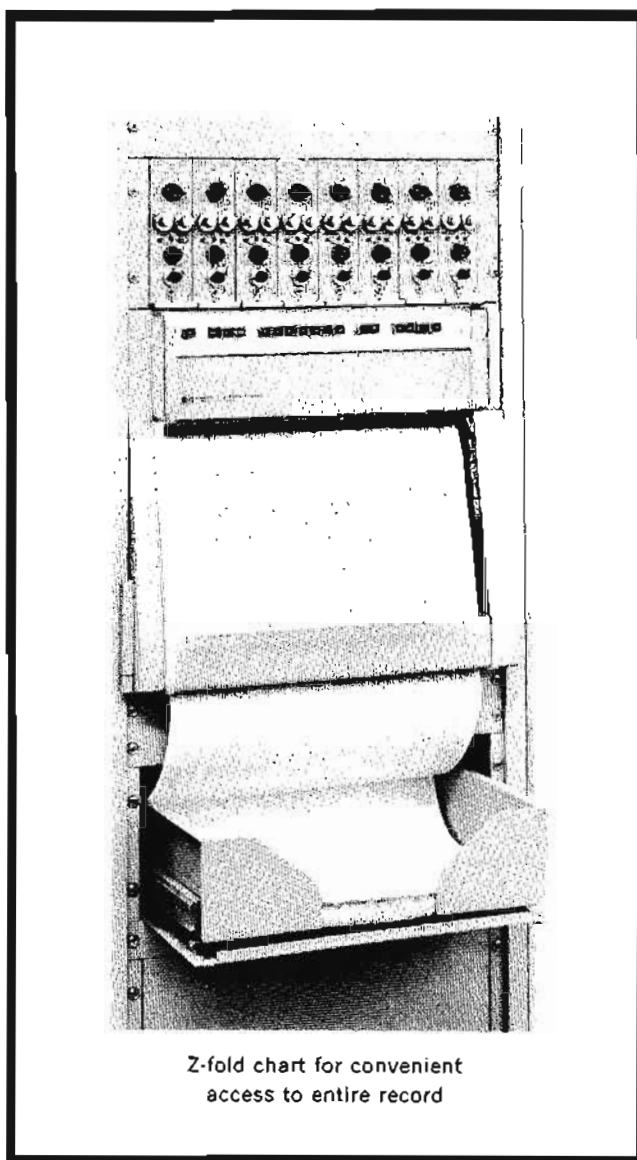

Z-fold chart for convenient access to entire record

**Weight:** approx. 550 lbs (249 kg) including full set of Preamplifiers and Cabinet or Carrying Case. Exact weight depends on equipment selected.

**Portability:** four large casters permit moving standard system as needed. Carrying Case Option 02 permits moving system to site of field measurements.

**Cooling:** cabinet vented top and bottom for natural air ventilation. Maximum ambient temperature outside case must not exceed 50°C. If vents are sealed, maximum ambient temperature outside case must not exceed 40°C.

**Environment:** system is designed to operate reliably in any location reasonably free from vibration, dust, corrosive or explosive gases or vapors, extremes of temperature, etc.



## RECTILINEAR INK RECORDER

New ink system records on Z-fold paper or rolls  
Model 7858A

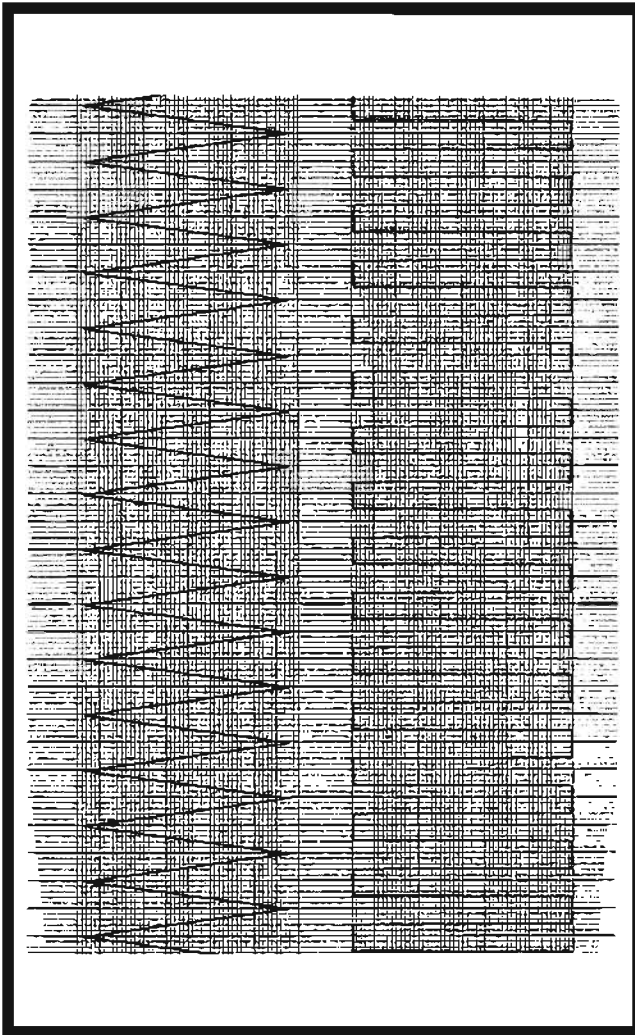

### Component description

**Ink recorder:** the recorder displays the system read-out data on a multi-channel recording chart. The illuminated recording is visible as soon as it is made, with the most recent ten inches remaining in view at all times. The recording process provides instantaneous, permanent, inked recording in rectilinear coordinates on HP Ink Recording Charts.

The recorder features include: 14 electrically-controlled chart speeds, selected by pushbuttons on the front panel; built-in paper take-up; low ink supply warning light; plug-in ink supply cartridge that may be replaced while recorder continues to operate; simple paper loading from the front and regulated low-pressure ink system. The Take-Up Drawer for Z-fold paper is optional. The recorder also has enclosed individual moving coil penmotors with adjustable electrical damping and limiting; contactless pen tip position feedback; provision for remote control of paper drive, paper speeds and markers; and a signal for low ink or end of roll is indicated on front panel and brought out to a remote connector.

**Driver amplifier:** one driver amplifier is provided for each recording penmotor. The combination of driver-amplifier and penmotor simulate the characteristics of a simple galvanometer with 71% of critical damping, with negative velocity-voltage feedback from the galvanometer damping control, in conjunction with the position feedback circuit.

**Driver amplifier and recorder power supply:** the Power Supply provides operating power for up to eight Driver Amplifier modules. Power is also supplied for all recording functions and is integral with recorder.

### Recorder specifications including driver amps

**Frequency response:** 160 Hz for 10 div p-p deflection or 60 Hz maximum for full scale deflection.

**Response time:** from 10% to 90% amplitude—

Total Deflection	Response Time
10 chart divisions	3 milliseconds
25 chart divisions	4 milliseconds
50 chart divisions	6 milliseconds

**Drift:** less than 1/10th chart division over temperature range from 20°C to 55°C and for line voltage variation from 103 to 127VAC.

**Gain stability:** 0.1% from 20°C to 55°C and over line voltage range of 103 to 127VAC.

**Sensitivity:**  $\pm 2.5$  volts full scale (4 cm channel width).

**Static linearity:** 0.5% full scale maximum non-linearity.

**Hysteresis:** previous signals do not affect recorded data by more than  $\pm 0.15$  divisions.



Ink dries on contact, leaves ultra-clear trace

**Penmotor:** one per recording channel, high-torque, moving coil drive. Single-ended drive coil plus a velocity-voltage feedback winding. Drive coil winding approximately 16 ohms and velocity coil approximately 35 ohms at room temperature. Sensitivity is approximately 16 mA/div.

**Limiting:** electrical limiting separately adjustable from  $\pm 12$  div. to 3 div. beyond full scale. Mechanical stops set beyond full scale.

**Noise:** not visible on recording, including drive circuit, with zero signal input.

**Chart:** 500 ft. rolls  $15\frac{3}{8}$ " wide, 4 cm, 50-division channel width rectilinear coordinate paper suitable for diazo or similar reproduction process. Also available in 600 sheet folded pack  $11.9" \times 15\frac{3}{8}"$ .

**Chart speed:** 14 speeds selected by seven pushbutton switches in conjunction with 1x and 100x pushbuttons. A remote pushbutton transfers all speeds and OFF-ON functions to a remote station and also provides a voltage which can be used to indicate remote readiness. Speeds: .025, .05, .10, .25, .50, 1.0, 2.0, 2.5, 5, 10, 25, 50, 100 and 200 mm/sec.

**Chart drive:** for a full roll or pack of paper, paper weave, is less than  $\pm 0.25$  div.

**Paper take-up:** internal roll. Accessible by pivoting the writing table down from the top. Optional Z fold drawer.

**Trace width:** recorded trace .010" wide. Base lines up to .020" wide during standby or for very slow chart speeds.

**Rectilinear linkage:** line is straight within 0.0025" in 4 cm. stylus pressure is 15 to 20 grams. Interchannel displacement along time axis is less than 0.005".

**Ink system:** pressurized in proportion to the instantaneous velocity of the pen tip. Five-ounce supply is capable of writing 1000 miles of line.

**Ink:** ink is permanent, non-smudging and dries on contact with Hewlett-Packard Ink Recording Paper.

**Stylus:** stainless steel tubular ink tube supported by a light-weight frame containing a sensing element for position sensing. Design life: over 40,000,000 full scale cycles.

**Timer/marker:** left margin marker provides timing pulse every minute or every second. Right margin marker provides positive deflection for event marking. Provision is made for markers between each channel.

**Remote operation:** connector provided for remote operation of chart drive, selection of chart speeds and operation of timer/markers.

**Recorder size:**  $17\frac{1}{2}$ " high, 19" wide, 23" deep (444 x 482 x 585 mm). (Including power supply and driver amps.)

**Weight:** approximately 170 lbs (77.1 kg).

**Power requirements:** 115 volts, 60 Hertz, 500 watts including Driver Amplifiers and Power Supply with synchronous motor chart drive.

**Fuses:** protection is provided for the galvanometers, driver amplifiers, power supply and drive motor. Failure in any channel will not affect operation of the other channels. Fuses for the line, power supply and drive motor are accessible when the recorder is extended.

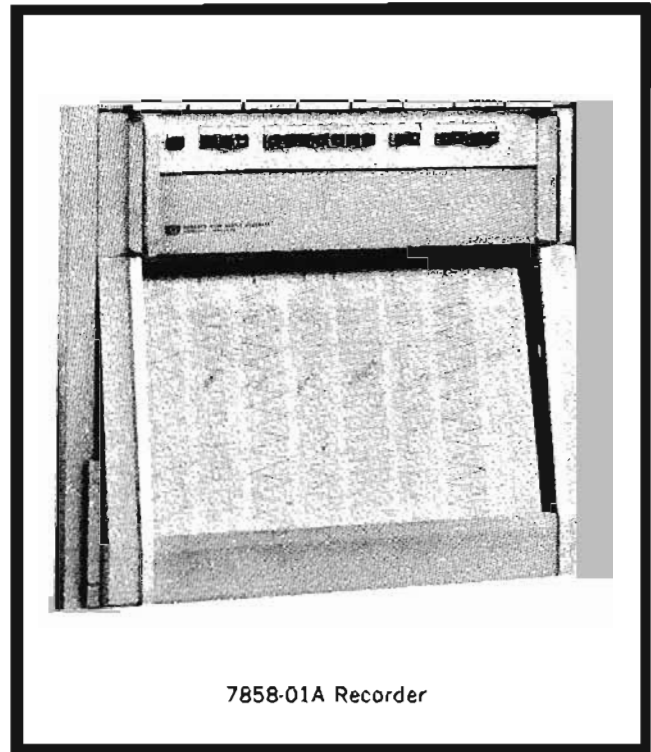

7858-01A Recorder

**Mounting:** on latch slide and frame assembly. Recorder locks in normal or extended positions.

### 8800 Series preamplifier description

These preamplifiers are compact, solid-state modules which plug into the system from the front to mate with the Preamplifier Power Supply. All connections to the Preamplifier are made at the Power Supply rear, although preamplifier outputs may be monitored from the front panel. AC excitation voltages are supplied to the Preamplifier as needed from plug-in oscillator circuit cards in the Power Supply. Preamplifier characteristics are shown on pages 136-144.

### Preamplifier power supply description

This power Supply provides operating power for up to eight "8800" Series Preamplifiers. It serves as a transfer chassis for signal input and output circuits and supplies the mounting facilities for sliding Preamplifiers into place to complete the system. The basic model Power Supply is identified as Model 8800-03A.

### Cabinet description

The Cabinet mounts and encloses all components of the recording system. The Master Power Panel above the Preamplifiers and the internal power and signal cabling are all considered a part of the cabinet. The cabinet is 72" high, 22" wide, 30" deep (1830 x 559 x 762 mm), including caster-wheel base which accounts for 2" of the height. The Cabinet weighs approximately 300 lbs (136 kg), including Power Panel and all internal wiring. Access is through rear door.



## OPTICAL RECORDER

For high-frequency, high-speed applications  
Model 4500

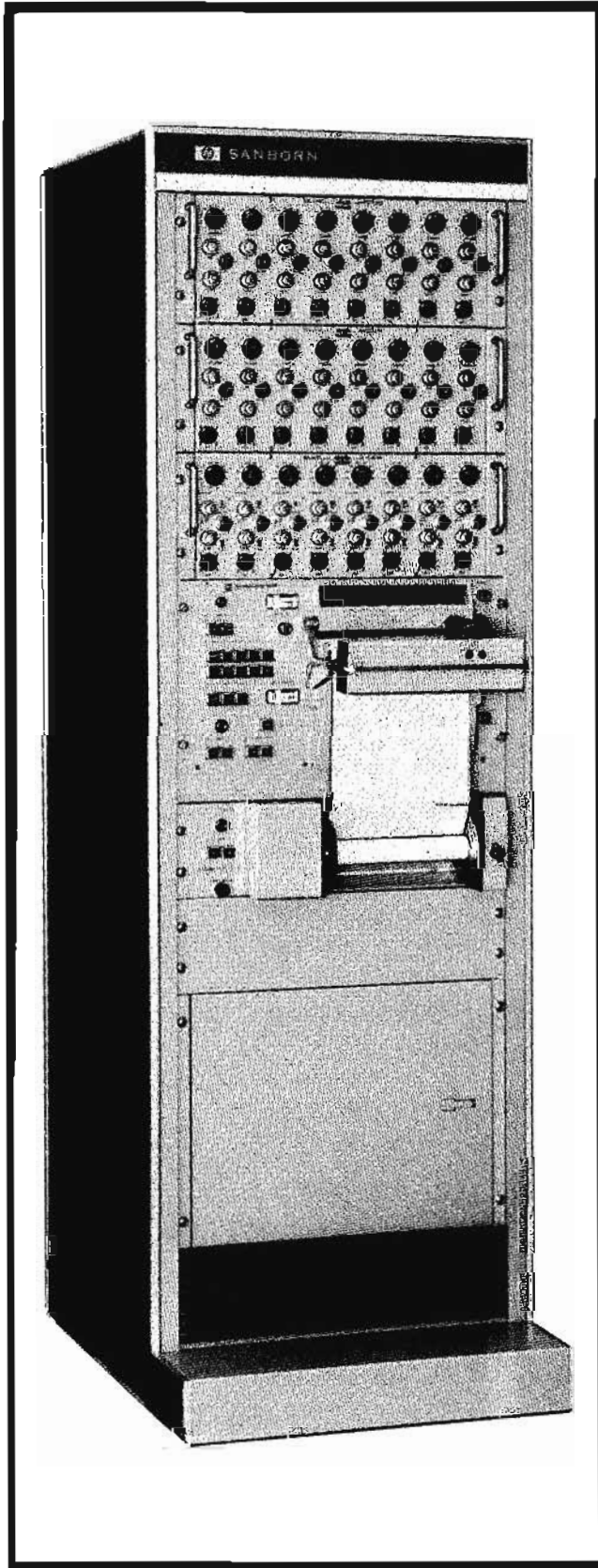

### Advantages:

- Up to 25 channels
- One basic galvanometer for 0 in 5 kHz response
- Sensitivities: 2.5 mV/in to 25 V/in
- Record up to 4" (p-p) amplitudes at 0 to 5 kHz;  
8" (p-p) at 0 to 3 kHz
- Trace positioned electrically anywhere on chart
- Uses 650 or 8800 amplifiers, preamplifiers

### Uses:

- Telemetry recording
- 400-cycle power measurements
- Transients measurements
- Measuring data sampled at high pulse rates

The HP Model 4500 Optical Recorder is a completely integrated system that can provide high-speed, permanent recordings of many variables, without annoying time delay errors between channels, in the 0 to 5000 cycle range. Per-channel cost is low, and the system is convenient to operate. Signals are connected directly to either front or rear panel of system multi-channel amplifiers and immediately recorded on 8-inch wide chart. Front-panel position controls make it easy to move each channel's trace to any position on chart.

For special applications, HP "8800 Series" preamplifier plug-ins can be combined with "650" amplifiers or used exclusively to drive the 4500 Series recorder. Complete specifications of 8800 preamps are tabulated on pages 136 to 141.

Amplifiers are available with maximum sensitivities of 2.5, 50 and 625 mV/in; with and without zero suppression and common mode voltages, and have zero drift, gain stability and noise ratings for high-quality amplification. Each amplifier assembly consists of eight identical, solid-state modular channels of electronics and a common power supply. Twenty-four channel systems are driven by three 8-channel amplifiers.

Special frequency boost and compensation circuits extend frequency response of 2 kHz galvanometers to 5 kHz range ( $-3$  dB). Current feedback in matching network between amplifier and galvanometer stabilizes frequency response of galvanometers over broad temperature range. Galvanometers of other natural frequencies are available for applications when the signal is to be applied directly to the recorder. Recordings can be made at any of nine speeds (0.25 to 100 in/sec) on ultraviolet-sensitive paper and immediately developed under attached post-development lamp. Traces may overlap at amplitudes up to eight inches. Additional features include: full-width (0.01 and 0.1 sec) timing lines, amplitude lines (removable over part or all of paper), sequential light beam interruption for trace identification, event marker, a lamp power control and meter and a meter for indicating remaining paper footage. As in most Hewlett-Packard recording systems, the 4500 has provision for complete remote operation.



## Specifications

**Channel capacity:** up to 25.

**Paper speeds:** standard recorders are supplied with 9 speeds: 0.25, 0.5, 1, 2.5, 5, 10, 25, 50 and 100 in/sec, electrically shifted and selected by front-panel pushbuttons; a connector and control panel are available for remote control of paper drive and speeds.

**Timing lines:** 0.01 or 0.1 sec interval lines recorded across the full chart width (8"); controlled from recorder panel or optional remote control panel.

**Amplitude lines:** 0.1" interval amplitude lines can be superimposed on total chart or eliminated over 0.25, 0.5 or 0.75 of full chart width; millimeter lines are available on special order.

**Galvanometer:** the Model 9B-1A is the standard galvanometer used in the 4500 System. One galvanometer is ordered for each recording channel to be utilized. Frequency compensation provided by the multi-channel amplifiers extends the frequency response of the 2 kHz Model 9B-1A Galvanometer to 5 kHz. Current feedback in the matching network between amplifier and galvanometer stabilizes the amplitude response of the galvanometer. The galvanometer is completely protected from burnout by limiting circuitry included in the amplifier compensation networks. Other natural frequency galvanometers may be obtained to be driven directly by user-supplied voltage and current sources.

**Controls:** Power On-Off, Timing Interval selector, Lamp Power Adjust, Lamp Off/Start, Paper Footage indicator, Event Marker, Paper Drive On/Off Jog pushbutton; all controls are on the front panel.

**Viewing:** calibrated periscope on front panel allows viewing the traces when recording or calibrating.

**Input characteristics:** each channel has both front and rear connector panels. All mating connectors supplied.

	658-2000	658-2900	658-3400
Sensitivity	625 mV/in	50 mV/in	2.5 mV/in
Input Circuit	Single-ended	Balanced to ground	Floating and guarded
Input Impedance	100 k $\Omega$	5 M $\Omega$	100 k $\Omega$

**Output (all amplifiers):**  $\pm 72$  mA to drive standard 2000 Hz galvanometers, 17-ohm nominal load, ungrounded, approx. 10,000 ohms source impedance; current is limited to  $\pm 150$  mA.

**Output monitor (amplifiers):** front-panel jack provides  $\pm 1$  V full scale across 100 k $\Omega$  min. load (658-2900 and 658-3400 only).

**Paper take-up:** optional 650-900 mounted below recorder; front-panel pushbutton automatically controls paper and take-up speed; clutch keeps paper taut; relay stops take-up at end of roll.

**Amplifier cooling:** 50 cfm min. air flow required at rear of amplifiers for proper cooling; when the amplifier or system is purchased without a cabinet or a portable case, and where the cabinet being used has sufficient depth (23") a blower can be installed on the rear of the amplifier for \$145; to or-

der an amplifier with this blower assembled, simply specify Option 02 after the amplifier model number (i.e. 658-2900, Option 02). Cabinet and portable case will provide all cooling required.

**Power:** 103 to 127 V, 60 Hz, 450 W (recorder); 103 to 127 V, 50 to 400 Hz, 125 W (amplifiers) (115 or 230 V on special order); 105 to 125 V, 60 Hz, 195 W (paper take-up) (115 or 230 V, 50 Hz on special order).

**Dimensions:** 4524-09A vertical mobile cabinet: 72½" high, 22-1/16" wide, 30" deep (841 x 560,4 x 762 mm). In portable cases: Recorder in 4500-06A portable case: 13¾" high, 20-3/16" wide, 17¾" deep (349,3 x 512,6 x 450,8 mm). Paper take-up in 4500-07A portable case: 7¼" high, 20-3/16" wide, 17¾" deep (180,8 x 512,6 x 450,8 mm). Multi-channel amplifier in 858-1400 portable case: 8¾" high, 21½" wide, 22¼" deep (212,6 x 574,1 x 565,2 mm). For rack mounting: Recorder; 12¼" high, 19" wide, 17¼" deep (310,2 x 482,6 x 438,2 mm). Paper take-up; 5¼" high, 19" wide, 15-5/16" deep (133,4 x 482,6 x 388,9 mm). Multi-channel amplifiers; 7" high, 19" wide, 20½" deep (177,8 x 482,6 x 520,7 mm). With built-in cooling fan (Option 02), depth is 23¾".

**Weights:** 4508B in vertical mobile cabinet; net 554 lbs (247,5 kg), shipping 650 lbs (292,5 kg). 4524B in vertical mobile cabinet; net 579 lbs (260,1 kg), shipping 675 lbs (303,3 kg). Recorder in 4500-06A portable case; net 130 lbs (58,5 kg), shipping 210 lbs (94,5 kg). Paper take-up in 4500-07A portable case; net 45 lbs (20,2 kg), shipping 60 lbs (27 kg). Multi-channel amplifier in 858-1400 portable case; net 120 lbs (53 kg), shipping 150 lbs (67,5 kg). Recorder; net 90 lbs (40,5 kg), shipping 150 lbs (67,5 kg). Paper take-up; net 25 lbs (11,2 kg), shipping 30 lbs (13,5 kg). Multi-channel amplifier; net 80 lbs (35 kg), shipping 90 lbs (40,5 kg).

### Prices:

*Model 4508B Eight-Channel Ultra-Violet Recorder* with cabinet, 115 V 60 Hz; does not include galvanometers or multi-channel amplifiers, \$4200. Option 01, same as above less cabinet; includes master power panel and rack slides for mounting in customer's cabinet, \$3725. Option 02, recorder only in portable case, \$3960. Option 08 for 50 Hz power line, no extra charge. Option 09, step-down transformer installed in cabinet for 230 V power line, 50 or 60 Hz, \$100 additional.

*Model 4524B Twenty-Five-Channel Ultra-Violet Recorder* with cabinet, 115 V 60 Hz; does not include galvanometers or multi-channel amplifiers, \$4400. Option 01, same as above less cabinet; includes master power panel and rack slides for mounting in customer's cabinet, \$3925. Option 02, recorder only in portable case, \$4160. Option 08 for 50 Hz power line, no extra charge. Option 09, step-down transformer installed in cabinet for 230 V power line, 50 or 60 Hz, \$100 additional.

**Accessories:** standard base recording paper, 200' roll (3A-26), \$22.50. Thin base recording paper, 350' roll (3A-27), \$37.75. Galvanometer (9B-1A, one required per recording channel), \$125. Dummy galvanometer without mirror (9B-1W), \$10. Dummy galvanometer with mirror (9B-1R), \$34. Paper take-up (650-900), \$650. Portable case for mounting paper take-up below recorder case (4500-07A), \$275. Portable case for mounting recorder (4500-06A), \$360. Portable case for one multi-channel amplifier, including cooling fan (858-1400), \$250.



## Specifications

Pre-amplifier type	Features	Maximum calibrated sensitivity & maximum full scale input	Sensitivity ranges	Input circuit and input frequency range
8801A Low Gain DC	Differential inputs; 5 mV/div sensitivity; calibrated zero suppression; internal calibration source; wide attenuation range	5 mV/div (gain, 20)  250 volts	5, 10, 20, 50, 100, 200, 500, 1000, 2000 and 5000 mV/div; accuracy = 1%	Resistance 500 k ohms $\pm$ 1% each side balanced to ground; in parallel with approx. 100 pF  DC to 10 kHz
8802A Med. Gain DC	Differential inputs; 1 mV/div sensitivity; calibrated zero suppression; internal calibration source; wide attenuation range	1 mV/div (gain, 100)  50 volts	1, 2, 5, 10, 20, 50, 100, 200, 500, and 1000 mV/div; accuracy = 1%	Resistance 180 k ohms $\pm$ 1% each side balanced to ground, in parallel with approx. 100 pF  DC to 10 kHz
8803A High Gain DC	High sensitivity, 1 $\mu$ V/div; low drift chopper amplifier circuit; guarded floating input; high input impedance; calibrated zero suppression up to 2000X full scale; internal calibration source	1 $\mu$ V/div (gain, 100,000)  250 volts	1, 2, 5, 10, 20, 50, 100, 200, 500, 1000, 2000 and 5000 $\mu$ V/div; 10, 20, 50, 100, 200, 500, 1000, 2000 and 5000 mV/div; accuracy $\pm$ 1% on 5000 $\mu$ V/div to 20 $\mu$ V/div ranges, $\pm$ 2% on 10 $\mu$ V/div to 1 $\mu$ V/div; accuracy of X1000 attenuator $\pm$ 1%	1 megohm min on microvolt range, independent of gain; 5 megohms on millivolt range; floating and guarded  DC to 110 Hz
8805A Carrier	Calibrated zero suppression; calibration factor control; high ac-dc gain, 10 $\mu$ V/div sensitivity; internal transducer excitation drive	10 $\mu$ V rms/div (gain, 10,000 rms ac to dc)  100 mV rms	X 1, 2, 5, 10, 20, 50 100 and 200; attenuation accuracy $\pm$ 2%	Approx. 10 k ohms; single ended transducer impedance; 5 k ohm max., 100 ohms minimum  440 Hz to 4800 Hz carrier reference frequency
8806B Phase Sens. Demod.	50 Hz to 40 kHz carrier (reference) frequency range; plug-in adjustable phase shift modules for optimum quadrature rejection; broad-band plug-in, 50 Hz to 40 kHz has uncalibrated phase shifter single-carrier-frequency plug-ins have calibrated phase shifter; high impedance, transformer— isolated, signal and reference inputs	0.5 mV rms/div, (gain, 200 rms ac to dc)  25 volts rms	Signal input: 0.5, 1, 2, 5, 10, 20, 50, 100, 200 and 500 mV rms/div; $\pm$ 1%, 50 Hz to 10 kHz $\pm$ 2%, 10 kHz to 20 kHz; $\pm$ 3%, 20 kHz to 40 kHz  Reference voltage: 3-133 volts rms in two overlapping ranges, internal range switch	Signal input: transformer isolated, floating and guarded; resistance approx. 1 megohm  Reference input: differential, transformer coupled; resistance approx. 500 k ohms each side to ground, may be used single ended  50 Hz to 40 kHz in bands with uncalibrated plug-in; 60 Hz, 400 Hz and 5 kHz calibrated phase shift plug-ins; special order phase shift plug-ins 50 Hz to 40 kHz
8807A AC/DC Conv.	Fast envelope response time; calibrated zero suppression; scale expansion for 0.02% resolution; floating and guarded 1 megohm input; internal calibration source	1 mV rms/div (gain, 100 rms ac to dc) 20 mV rms/div with X1 scale expansion  500 volts rms	0.02, 0.05, 0.1, 0.2, 0.5, 1, 2, 5, and 10 volts rms/div, $\pm$ 2% (midband) scale expansion: X1, X2, X5, X10, and X20, $\pm$ 2%	Approx. 1 megohm resistive in parallel with 10 pF and stray cable capacitance; floating and guarded  Standard model: 330 Hz to 100 kHz; option 01: 50 Hz to 100 kHz
8808A Log Level	100 dB and 50 dB detection spans; $\pm$ 1 dB detection accuracy; thirteen ranges; 100 $\mu$ V maximum sensitivity (bottom scale); internal calibration source	100 $\mu$ V rms sine wave corresponds to bottom scale output, -80 dB below 1 volt  320 volts rms	50 dB span: bottom scale at -80, -70, -60, -50, -40, -20, -10 and 0 dB below 1 volt (i.e., 100 $\mu$ V, 320 $\mu$ V, 1, 3.2, 10, 32, 100, 320 mV and 1 volt)  100 dB span: bottom scale at -80, -70, -60 and -50 dB below 1 volt	Single ended, resistance 1 megohm min.  5 Hz to 100 kHz for less than 3 dB down from mid-band level on "slow" response range; 500 Hz to 100 kHz on "fast" response range
8809A Spec. Purpose DC	Switch selected input impedance; 0 to 1 mA into 1.5 k ohm input impedance for edge-to-edge chart deflection; full scale positioning; internal calibration source	30 mV/div (gain, 3.33)  0 to +2.5 V or 0 to -2.5 V	Continuously adjustable from 20 to 50 mV/div	Switch selected: 1500 ohms $\pm$ 2% or 100 k ohms min. incremental; single ended (floating in 770A only)  DC to 5 kHz



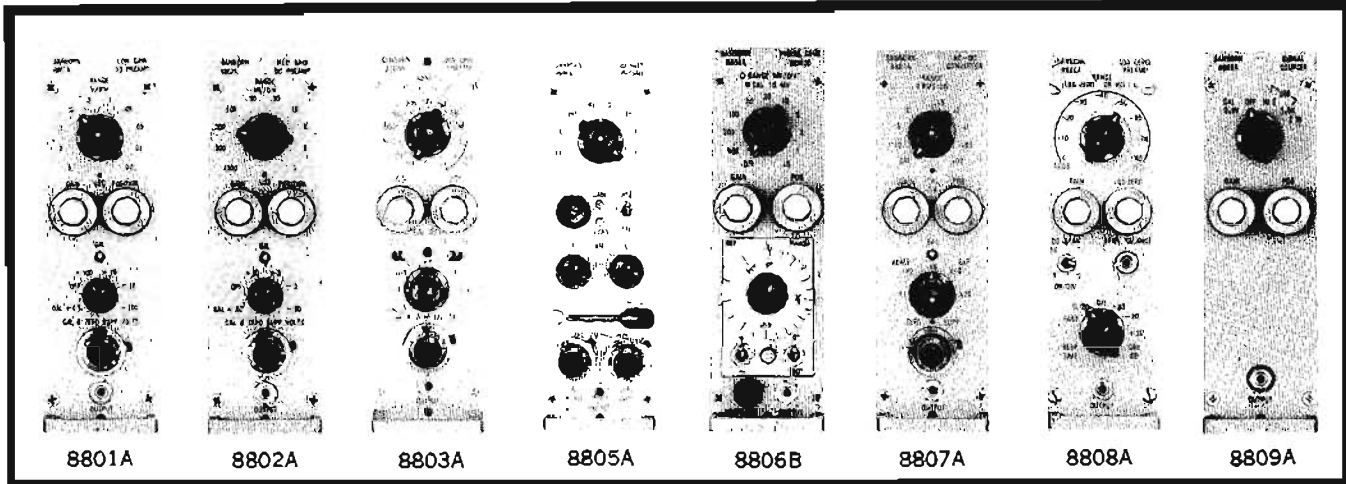

Pre-amplifier type	Zero suppression	Calibration (referred to input)	Common mode rejection & tolerance
8801A Low Gain DC	$\pm 10$ and $\pm 100$ volts for single-ended or differential signals; 10-turn potentiometer sets precise values of zero suppression voltages, $\pm 50$ volts max. suppression on 5, 10, 20 mV/div ranges; max error of suppression; $\pm 0.5\%$ of suppression range and 1% of indicated suppression	100 mV, $\pm 1\%$ internal	48 dB min. dc to 150 Hz; $\pm 50$ volts on 5, 10, 20 mV/div ranges; $\pm 500$ volt max on other ranges for less than $\pm 1\%$ change in differential sensitivity
8802A Med. Gain DC	$\pm 2$ volts and $\pm 20$ volts for single-ended or differential signals; 10-turn potentiometer sets precise values of zero suppression voltages; $\pm 12.5$ volts max suppression on 1, 2, 5 mV/div ranges; max error of suppression: $\pm 0.5\%$ of suppression range and 1% of indicated suppression	20 mV, $\pm 1\%$ internal	48 dB min, dc to 60 Hz, 1000 mV/div range; 48 dB min dc to 150 Hz all other ranges; $\pm 12\frac{1}{2}$ volts on 1, 2, 5 mV/div ranges; $\pm 125$ volts on 10, 20, 50 mV/div ranges; $\pm 500$ volts max other ranges for less than $\pm 1\%$ change in differential sensitivity
8803A High Gain DC	$\mu\text{V}$ ranges: $\pm 1$ , $\pm 10$ , $\pm 100$ mV; mV ranges: $\pm 1$ , $\pm 10$ , $\pm 100$ volts; 10-turn potentiometer sets precise values of zero suppression voltages; accuracy $\pm 1\%$ of full scale	200 $\mu\text{V}$ $\pm 1\%$ internal on $\mu\text{V}/\text{div}$ range 200 mV $\pm 1\%$ internal on mV/div range	$\mu\text{V}$ range, max source unbalance of 1 k ohms; 160 dB min at dc, 120 dB min at 60 Hz; mV range, max source unbalance of 500 k ohms; 100 dB min at dc, 60 dB min at 60 Hz DC: 300 V peak; 60 Hz; 1 $\mu\text{V}/\text{div}$ , 10 V rms; 2 $\mu\text{V}/\text{div}$ , 20 V rms; 5 $\mu\text{V}/\text{div}$ , 50 V rms; 10 $\mu\text{V}/\text{div}$ and 10 mV/div, 100 V rms; 20 $\mu\text{V}$ to 5000 $\mu\text{V}/\text{div}$ and 20 mV to 5000 mV/div, 220 V rms
8805A Carrier	0-100% of transducer full load rating, 10-turn potentiometer with calibrated dial; accuracy: one dial division $\approx 0.5\%$ of full scale	2% $\approx 0.02\%$ of transducer full scale output; CAL signal in $\mu\text{V}$ may be read from the CAL factor dial	Quadrature rejection & tolerance: Greater than 40 dB. Tolerance: error less than $\pm 2\%$ full scale when quadrature voltage is equal to twice in-phase signal required for full output
8806B Phase Sens. Demod.	None	1 volt rms internal at carrier reference frequency; $\pm 1\%$ 50 Hz to 10 kHz; $\pm 2\%$ 10 kHz to 20 kHz; $\pm 3\%$ 20 kHz to 40 kHz	Common Mode: Greater than 40 dB up to 10 kHz; 500 V rms, maximum; Quadrature tolerance: equal to the amplitude of a full scale in-phase signal
8807A AC/DC Conv.	Zero suppression: up to 100% of full scale on any range can be suppressed; 10-turn potentiometer with calibrated dial; scale expansion: 5, 10, 20, or 50% of full scale can be expanded to cover full chart	1 volt internal $\pm 1\%$ ; approximately 500 Hz	60 dB min at 60 Hz; 40 dB min at 400 Hz with up to 10 k: source unbalance; $\pm 500$ volts peak
8808A Log Level	None	Internal -80, -30 and +20 dB V; dB V referred to 1 volt (100 $\mu\text{V}$ , 32 mV and 10 V full scale)	None
8809A	None	600 mV $\pm 2\%$ , internal	50,000:1 at dc; $\pm 50$ volts max; (7701A only)

**Preamplifier/Model 7701A Recorder System Specifications**  
 (Specifications apply only when Permapaper® is used)

Pre-amplifier type	Output linearity (less trace width)	Output noise maximum (less trace width)	Output frequency response (10 cm) do to less than 3 dB down at	Rise time (10 div, 10-90% 4% overshoot)	Gain stability 20° to 40°C, 103 to 127 volts	Zero drift (less trace width) 28° to 40°C, 103 to 127 volts
8801A Low Gain DC	0.25 div method 1 <sup>1</sup>	0.2 div p-p	30 Hz	20 msec	Temperature: 0.35%/10°C Line voltage: 0.6%	Temperature: 1.25 div/10°C; 0.5 div/8 hr, constant ambient Line voltage: 0.35 div
8802A Med. Gain DC	0.25 div method 1 <sup>1</sup>	0.2 div p-p	30 Hz	20 msec	Temperature: 0.35%/10°C Line voltage: 0.6%	Temperature: 1.25 div/10°C; 0.5 div/8 hr, constant ambient Line voltage: 0.35 div
8803A High Gain DC	1 mV range 0.35 div Other ranges 0.25 div method 1 <sup>1</sup>	1 div p-p maximum gain 0.1 div p-p minimum gain	30 Hz	20 msec	Temperature: 0.35%/10°C  Line voltage: 0.75%, 1 mV/div to 5 mV/div; 0.55% all other ranges	Temperature: $\mu$ V range: 1 $\mu$ V/10°C referred to input $\approx$ 0.65 div/10°C for full scale output  mV range: 1 mV/10°C referred to input $\approx$ 0.26 div/10°C for 0 output and $\approx$ 0.65 div/10°C for full scale output  Line voltage: Output 0.27 div; full scale output 0.45 div
8805A Carrier	0.4 div method 1 <sup>1</sup>	0.2 div p-p +1% of chart deflection	30 Hz	20 msec	Temperature: 0.45%/10°C Line voltage: 0.75%	Temperature: 0.45 div/10°C Line voltage: 0.35 div
8806B Phase Sens. Demod.	0.4 div method 1 <sup>1</sup>	7 $\mu$ V x square root of combined 8806B recorder frequency response, p-p, referred to input	$\frac{1}{\sqrt{\left(\frac{5}{f_c}\right)^2 + \left(\frac{1}{30}\right)^2}}$ <small>f<sub>c</sub> = carrier reference frequency in Hz</small>	$\sqrt{\left(\frac{3000}{f_c}\right)^2 + (0.02)^2}$ sec <small>f<sub>c</sub> = carrier reference frequency in Hz</small>	Temperature: 0.5%/10°C Line voltage: 0.6%	Temperature: 0.5 div/10°C Line voltage: 0.35 div
8807A AC/DC Conv.	0.55 div +0.05 div x scale expansion 60 Hz to 5 kHz method 2 <sup>1</sup>	Baseline offset and/or noise 2 mV rms referred to input plus 0.025 div x scale expansion	27 Hz Option 01: 9 Hz	22 msec Option 01: 73 msec (Approx. 10% overshoot)	Temperature: 0.2%/10°C x scale expansion + 0.45%/10°C Line voltage: 0.24% x scale expansion + 0.75%	Temperature 0.03 div/10°C x scale expansion + 0.35 div/10°C; 0.005 div/hr x scale expansion at constant ambient Line voltage: 0.005 div x scale expansion plus 0.30 div
8808A Log Level	Departure from log characteristic 50 dB: 1.25 div method 2 <sup>1</sup> 100 dB: 1 div method 2 <sup>1</sup>	50 dB range: 0.8 div p-p 100 dB range: 0.4 div p-p  (Maximum noise at bottom of recording chart)	Does not apply	Fast: 28 msec (825 dB/sec) Slow: 2 sec (9 dB/sec)	Temperature: 60 dB range 2.13 dB/10°C; 100 dB range 2.25 dB/10°C Line voltage: 50 dB range 0.75 dB 100 dB range 1.0 dB  (Maximum gain at bottom of recording chart)	Does not apply (with input shorted output is off-scale at bottom of chart)
8809A Spec. Purpose DC	0.4 div method 1 <sup>1</sup>	0.1 div p-p	30 Hz	20 msec	Temperature: 0.75%/10°C Line voltage: 1%	Temperature: 0.4 div/10°C at 30 mV sensitivity Line voltage: 0.50 div.

Method 1: After setting mechanical zero of stylus within  $\pm$ 1 division of chart center and calibrating for zero error at center scale and +20 divisions, error is as shown above at any point on printed coordinates.

Method 2: After setting mechanical zero of stylus to chart center  $\pm$ 1 division and calibrating for zero error at lower and upper ends of printed coordinates, error is as shown above at any point on scale.



Low Gain DC

8801A



Med. Gain DC

8802A

### Preamplifier/Model 7702A Recorder System Specifications

(Specifications apply only when Permapaper® is used)

Pre-amplifier type	Output linearity (less trace width)	Output noise maximum (less trace width)	Output frequency response (10 cm) dc to less than 3 dB down at	Rise time	Gain stability 20° to 40°C, 103 to 127 volts	Zero drift (less trace width) 20° to 40°C, 103 to 127 volts
8801A Low Gain DC	0.25 div method 1 <sup>1</sup>	0.2 div p-p	125 Hz	5 msec	Temperature: 0.35%/10°C Line voltage: 0.6%	Temperature: 1.25 div/10°C; 0.5 div/8 hr, constant ambient Line voltage: 0.70 div
8802A Med. Gain DC	0.25 div method 1 <sup>1</sup>	0.2 div p-p	125 Hz	5 msec	Temperature: 0.35%/10°C Line voltage: 0.6%	Temperature: 1.25 div/10°C; 0.5 div/8 hr, constant ambient Line voltage: 0.70 div
8803A High Gain DC	1 mV range 0.35 div Other ranges 0.25 div Method 1 <sup>1</sup>	1 div p-p maximum gain 0.1 div p-p minimum gain	90 Hz	7 msec	Temperature: 0.35%/10°C  Line voltage: 0.75%, 1 mV/div to 5 mV/div; 0.55% all other ranges	Temperature: $\mu$ V range: 1 $\mu$ V/10°C referred to input = 0.65 div/10°C for full scale output  mV range: 1 mV/10°C referred to input = 0.26 div/10°C for 0 output and = 0.65 div/10°C for full scale output  Line voltage: 0 output 0.27 div; full scale output 0.45 div
8805A Carrier	0.4 div method 1 <sup>1</sup>	0.2 div p-p +1% of chart deflection	110 Hz	5.6 msec	Temperature: 0.45%/10°C Line voltage 0.75%	Temperature: 0.45 div/10°C Line voltage: 0.35 div
8806B Phase Sens. Demod.	0.4 div method 1 <sup>1</sup>	7 $\mu$ V x square root of combined 8806B recorder p-p frequency response referred to input	$\frac{1}{\sqrt{\left(\frac{5}{f_c}\right)^2 + \left(\frac{1}{125}\right)^2}}$ Hz <i>f<sub>c</sub></i> = carrier reference frequency in Hz	$\sqrt{\left(\frac{3000}{f_c}\right)^2 + (0.005)^2}$ sec <i>f<sub>c</sub></i> = carrier reference frequency in Hz	Temperature: 0.5%/10°C Line voltage: 0.6%	Temperature: 0.5 div/10°C Line voltage: 0.35 div
8807A AC/DC Conv.	0.55 div +0.05 div x scale expansion, 60 Hz to 5 kHz, method 2 <sup>1</sup>	Baseline offset and/or noise: 2 mV rms referred to input plus 0.025 div x scale expansion	54 Hz Option 01: 9 Hz	11.2 msec Option 01: 70 msec (Approx. 10% overshoot)	Temperature: 0.2%/10°C x scale expansion +0.45%/10°C  Line voltage: 0.25% x scale expansion +0.75%	Temperature: 0.03 div/10°C x scale expansion +0.35 div/10°C; 0.005 div/hr x scale expansion at constant ambient  Line voltage: 0.005 div x scale expansion plus 0.30 div
8808A Log Level	Departure from log characteristic 50 dB: 1.25 div method 2 <sup>1</sup> 100 dB: 1 div method 2 <sup>1</sup>	50 dB: range 0.8 div p-p 100 dB: range 0.4 div p-p  (Max. noise at bottom of recording chart)	Does not apply	Fast: 20.5 msec (875 dB/sec) Slow: 2 sec (9 dB/sec)	Temperature: 50 dB range; 2.13 dB/10°C  Line Voltage: 50 dB: range 0.75 dB 100 dB: range: 1.0 dB  Maximum gain at bottom of recording chart)	Does not apply. (With input shorted output is off-scale at bottom of chart.)
8809A Spec. Purpose DC	0.4 div method 1 <sup>1</sup>	0.1 div p-p	125 Hz	5 msec	Temperature: 0.75%/10°C Line voltage: 1%	Temperature: 0.4 div/10°C at 30 mV sensitivity Line voltage: 0.50 div

Method 1: After setting mechanical zero of stylus within  $\pm 1$  division of chart center and calibrating for zero error at center scale and  $\pm 20$  divisions, error is as shown above at any point on printed coordinates.

Method 2: After setting mechanical zero of stylus to chart center  $\pm 1$  division and calibrating for zero error at lower and upper ends of printed coordinates, error is as shown above at any point on scale

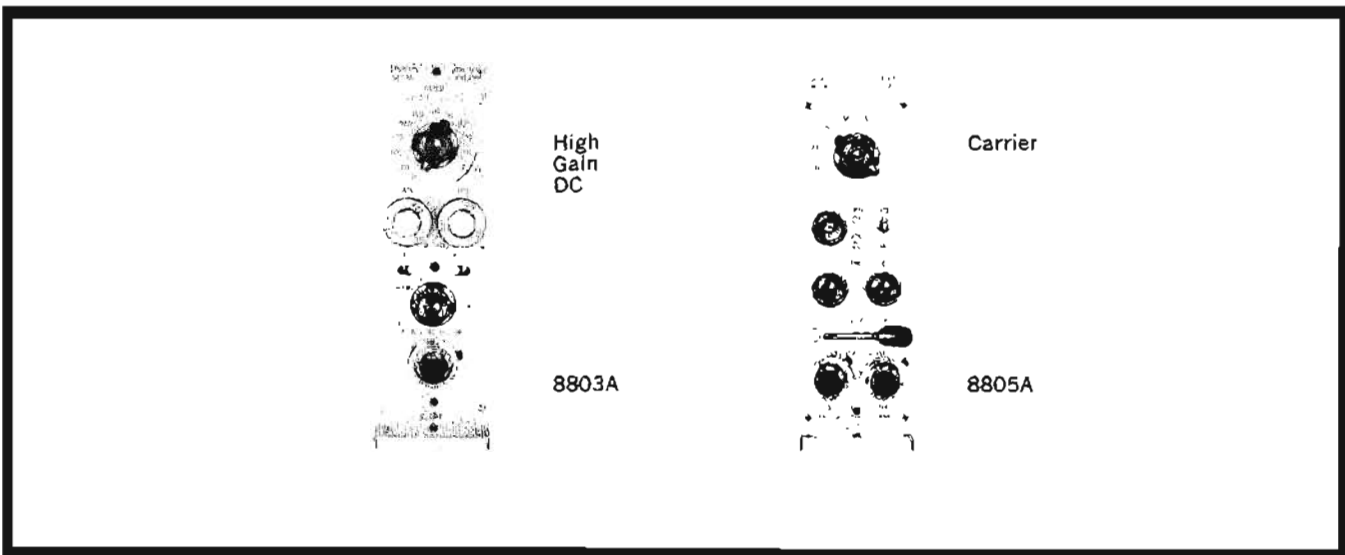

Preamplifier/Model 7704A Recorder System Specifications

Pre-amplifier type	Output linearity (less trace width)	Output noise maximum (less trace width)	Output frequency response (10 div) dc to less than 3 dB down at	Rise time (10 div; 10-90% 4% overshoot)	Gain stability 20° to 40°C, 103 to 127 volts	Zero drift (less trace width) 20° to 40°C 103 to 127 volts
8801A Low Gain DC	0.25 div method 1 <sup>1</sup>	0.2 div p-p	125 Hz	5 msec	Temperature: 0.2%/10°C Line voltage: 0.25%	Temperature: 1.25 div/10°C; 0.5 div/8 hr, constant ambient Line voltage: 0.15 div
8802A Med. Gain DC	0.25 div method 1 <sup>1</sup>	0.2 div p-p	125 Hz	5 msec	Temperature: 0.2%/10°C Line voltage: 0.25%	Temperature: 1.25 div/10°C; 0.5 div/8 hr, constant ambient Line voltage: 0.15 div
8803A High Gain DC	1 mV range 0.35 div Other ranges 0.25 div, method 1 <sup>1</sup>	1 div p-p maximum gain 0.1 div p-p minimum gain	90 Hz	7 msec	Temperature: 0.2%/10°C Line voltage: 0.4%, 1 mV/div to 5 mV/div; 0.2% all other ranges	Temperature: $\mu$ V range: 1 $\mu$ V/10°C referred to input = 0.26 div/10°C for 0 output and = 0.65 div/10°C or full scale output mV range 1 mV/10°C referred to input = 0.26 div/10°C for 0 output and = 0.65 div/10°C for full scale output Line voltage: 0 output 0.07 div full scale output 0.35 div
8805A Carrier	0.4 div method 1 <sup>1</sup>	0.2 div p-p + 1% of chart deflection	110 Hz	5.6 msec	Temperature: 0.3%/10°C Line voltage: 0.4%	Temperature: 0.45 div/10°C Line voltage: 0.25 div
8806B Phase Sens. Demod.	0.4 div method 1 <sup>1</sup>	7 $\mu$ V x square root of combined 8806B recorder frequency response, p-p, referred to input	$\frac{1}{\sqrt{\left(\frac{5}{f_c}\right)^2 + \left(\frac{1}{125}\right)^2}} \text{ Hz}$ $f_c = \text{carrier reference frequency in Hz}$	$\sqrt{\left(\frac{3000}{f_c}\right)^2 + (.005)^2} \text{ sec}$ $f_c = \text{carrier reference frequency in Hz}$	Temperature: 0.35%/10°C Line voltage: 0.25%	Temperature: 0.5 div/10°C Line voltage: 0.25 div
8807A AC/DC Conv.	.055 div + 0.5 div x scale expansion. 60 Hz to 5 kHz, method 2 <sup>1</sup>	Baseline offset and/or noise: 2 mV referred to input plus 0.025 div x scale expansion	54 Hz Option 01: 9 Hz	11.2 msec Option 01: 70 msec (Approx 10% overshoot)	Temperature: 0.2%/10°C x scale expansion + 0.3%/10°C Line voltage: 0.24% x scale expansion + 0.4%	Temperature: 0.03 div/10°C x scale expansion + 0.35 div/10°C; 0.005 div/hr x scale expansion at constant ambient Line voltage: 0.005 div x scale expansion plus 0.1 div
8808A Log Level	Departure from log characteristic 50 dB: 1.25 div method 1 <sup>1</sup> 100 dB: 1 div method 2 <sup>1</sup>	50 dB range: 0.8 div p-p 100 dB range: 0.4 div p-p  (Max. noise at bottom of recording chart)	Does not apply	Fast: 20.5 msec (875 dB/sec) Slow: 2 sec (9 dB/sec)	Temperature: 50 dB range: 2.05 dB/10°C; 100 dB range: 2.1 dB/10°C Line voltage: 50 dB range: 0.58 dB; 100 dB range: 0.65 dB (Maximum gain at bottom of recording chart)	Does not apply. (With input shorted output is off-scale on bottom of chart.)
8809A Spec. Purpose DC	0.4 div method 1 <sup>1</sup>	0.1 div p-p	125 Hz	5 msec	Temperature: 0.6%/10°C Line voltage: 0.65%	Temperature: 0.4 div/10°C at 30 mV sensitivity Line voltage: 0.3 div

Method 1: For setting mechanical zero of stylus within  $\pm 1$  division of chart center and calibrating for zero error at center scale and +20 divisions, error is as shown above at any point on scale.  
Method 2: For setting mechanical zero of stylus to chart center = 1 division and calibrating for zero error at lower and upper ends of printed coordinates, error is as shown above at any point on scale.

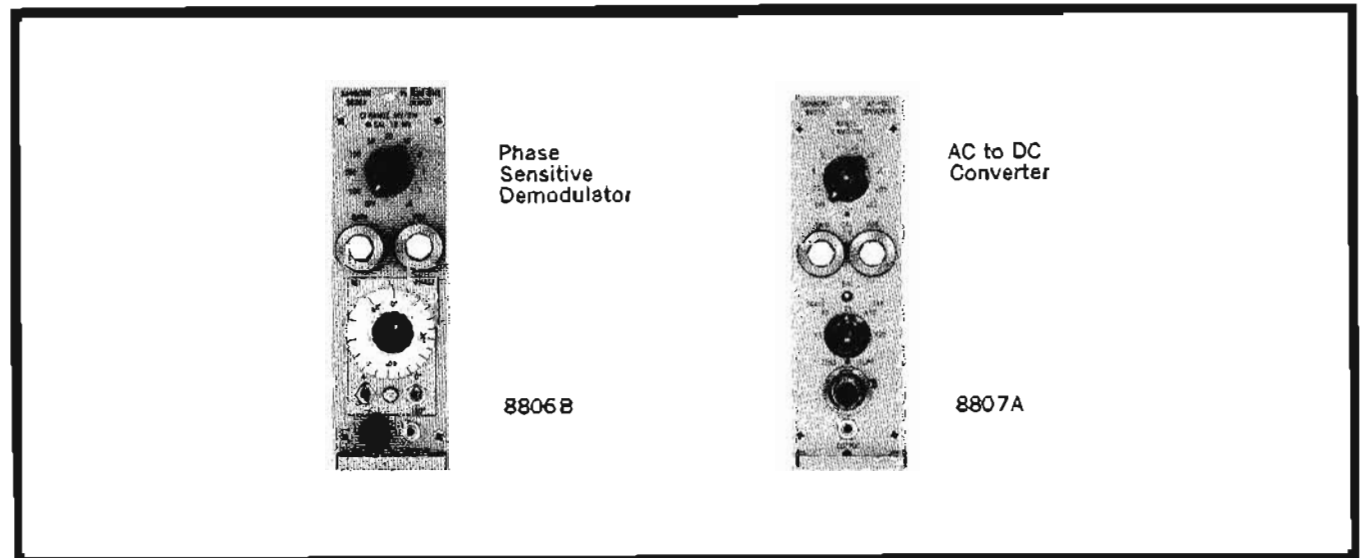

## Pre-amplifier—Model 7706A—7708A Recorder System Specifications

(Specifications apply only when Permapaper® is used)

Pre-amplifier type	Output linearity (less trace width)	Output noise maximum (less trace width)	Output frequency response (10 div) de to less than 3 dB down at	Rise time (10 div, 10-80%, less than 4% overshoot)	Gain stability	Zero drift (less trace width)
8801A Low Gain DC	0.25 div method 1 <sup>1</sup>	0.2 div p-p	7706A: 125 Hz 7708A: 150 Hz	7706A: 5 msec 7708A: 4 msec	Temperature: 0.2%/10° >, 10° to 40°C  Line voltage: 0.25%, 103 to 127 V	Temperature: 1.05 div/10°C, 10° to 40°C; 0.5 div/8hr, constant ambient  Line voltage: 0.15 div, 103 to 127 V
8802A Med. Gain DC	0.25 div method 1 <sup>1</sup>	0.2 div p-p	7706A: 125 Hz 7708A: 150 Hz	7706A: 5 msec 7708A: 4 msec	Temperature: 0.2%/10° >, 10° to 40°C  Line voltage: 0.25%, 103 to 127 V	Temperature: 1.05 div/10°C, 10° to 40°C; 0.5 div/8hr, constant ambient  Line voltage: 0.15 div, 103 to 127 V
8803A High Gain DC	1 mV range: 0.35 div Other ranges: 0.25 div method 1 <sup>1</sup>	1 div p-p maximum gain 0.1 div p-p minimum gain	7706A: 90 Hz 7708A: 100 Hz	7706A: 7 msec 7708A: 6.4 msec	Temperature: 0.2%/10° C, 20° to 40°C  Line voltage: 0.4%, 1 mV/div to 5 mV/div, 0.2%; other ranges; 103 to 127 V	Temperature: 20° to 40°C; $\mu$ V range: 1 $\mu$ V/10°C referred to input, =0.06 div/10°C for 0 output and =0.45 div/10°C for full scale output  mV range: 1 mV/10°C referred to input, =0.06 div/10°C for 0 output and =0.45 div/10°C for full scale output  Line voltage: 0 output: 0.07 div; full scale output: 0.35 div, 103 to 127 V
8805A Carrier	0.4 div method 1 <sup>1</sup>	0.2 div p-p + 1% of chart deflection	7706A: 110 Hz 7708A: 120 Hz	7706A: 5.6 msec 7708A: 4.75 msec	Temperature: 0.3%/10° C, 0° to 40°C  Line voltage: 0.4%, 103 to 127 V	Temperature: 0.25 div/10°C, 0° to 40°C  Line voltage: 0.25 div, 103 to 127 V
8806B Phase Sens. Demod.	0.4 div method 1 <sup>1</sup>	7 $\mu$ V x square root of combined 8806B recorder p-p frequency response, referred to input	706A: $\frac{1}{\sqrt{\left(\frac{5}{f_c}\right)^2 + \left(\frac{1}{125}\right)^2}}$ Hz 708A: $\frac{1}{\sqrt{\left(\frac{5}{f_c}\right)^2 + \left(\frac{1}{150}\right)^2}}$ Hz $f_c$ = carrier reference frequency in Hz	706A: $\frac{1}{\sqrt{\left(\frac{3000}{f_c}\right)^2 + (.005)^2}}$ sec 708A: $\frac{1}{\sqrt{\left(\frac{3000}{f_c}\right)^2 + (.004)^2}}$ sec $f_c$ = carrier reference frequency in Hz	Temperature: 0.35%/10° C, 0° to 40°C  Line voltage: 0.25%, 103 to 127 V	Temperature: 0.3 div/10° C, 0° to 40°C  Line voltage: 0.25 div, 103 to 127 V
8807A AC/DC Conv.	0.55 div + 0.05 div x scale expansion, 60 Hz to 5 kHz, method 2 <sup>1</sup>	Baseline offset and/or noise: 2 mV rms referred to input plus 0.025 div x scale expansion	7706A: 8807A: 54 Hz 8807A: Option 01: 9 Hz  7708A: 8807A: 55 Hz 8807A: Option 01: 9 Hz	7706A: 8807A: 11.2 msec 8807A: Option 01: 70 msec  7708A: 8807A: 10.8 msec 8807A: Option 01: 70 msec (Approx 10% overshoot)	Temperature: 0.2%/10° C x scale expansion +0.3%/10°C, 10° to 50°C  Line voltage: 0.24% x scale expansion +0.4%, 103 to 127 V	Temperature: 0.03 div/10° C x scale expansion +0.15 div/10°C, 10° to 50°C; 0.005 div/hr x scale expansion at constant ambient  Line voltage: 0.005 div x scale expansion +0.1 div, 103 to 127 V
8808A Log Level	Departure from log characteristic 50 dB: 1.25 div 100 dB: 1 div method 2 <sup>1</sup>	50 dB range: 0.8 div p-p 100 dB range: 0.4 div p-p  (Max. noise at bottom of recording chart)	Does not apply	7706A/7708A: Fast: 20.5 msec (875 dB/sec) Slow: 2 sec (9 dB/sec)	Temperature: 0° to 40°C; 50 dB range 2.05 dB/10° C; 100 dB range 2.1 dB/10°C  Line voltage: 103 to 127 V; 50 dB range 0.58 dB; 100 dB range 0.65 dB  (Maximum gain at bottom of recording chart)	Does not apply. (With input shorted output is off-scale on bottom of chart)
8809A Spec. Purpose DC	0.4 div method 1 <sup>1</sup>	0.1 div p-p	7706A: 125 Hz 7708A: 150 Hz	7706A: 5 msec 7708A: 4 msec	Temperature: 0.6%/10° C, 10° to 40°C  Line voltage: 0.65%, 103 to 127 V	Temperature: 0.2 div/10° C at 30 mV/div sensitivity, 0° to 40°C  Line voltage: 0.3 div, 103 to 127 V

Method 1: <sup>1</sup> or setting mechanical zero of stylus within  $\pm 1$  division of chart center and calibrating for zero error at center scale and  $\pm 20$  divisions, error is as shown above at any point on printed coordinates.  
Method 2: <sup>2</sup> or setting mechanical zero of stylus to chart center  $\pm 1$  division and calibrating for zero error at lower and upper ends of printed coordinates, error is as shown above at any point on scale.

Log-Level  
(Log Converter)

8808A

Special  
Purpose  
DC

8809A

# RECORDERS



## 950 SYSTEM AMPLIFIERS

Economical, variable gain for Thermal Writing  
950 Series for 7728A and 7726A

Model	958-3600	958-2900	958-3400	958-1500
Amplifier type	low-gain dc	medium-low gain dc	medium-gain dc	high-gain dc
Max. sensitivity	50 mV/div	10 mV/div	0.5 mV/div	10 $\mu$ V/div
Attenuation range	0.05, 0.1, 0.2, 0.5, 1 and 2 V/div, attenuator error $\approx$ 2% max.	10, 20, 50, 100, 200, and 500 mV/div; 1, 2, 5 and 10 V/div; attenuator error $\approx$ 2%	0.5, 1, 2, 5, 10 and 20 mV/div; 0.5, 1, 2, 5, 10 and 20V/10 div; attenuator error $\approx$ 2%	10, 20, 50, 100, 200, 500, 1000 and 2000 $\mu$ V/div; attenuator error $\approx$ 2%
Input circuit	550 K each side balanced to ground, except 500 K on negative input side on three most sensitive ranges	5 megohms each side balanced to ground	0.5 megohm on mV ranges, 1 megohm on volt ranges, input is floating and guarded from chassis	100 K all ranges, floating and guarded from chassis
Zero suppression	precedes signal attenuation and gain control, may be used with single-ended and balanced inputs; $\approx$ 40V max. suppression referred to input	follows attenuator switch and precedes gain control, may be used with single-end and balanced inputs; suppresses $\approx$ 2.5 V max. on most sensitive range, corresponding to max. suppression of 10 times center of chart to either edge on any range	none	none
Common mode or quadrature rejection ratio	typically more than 40 dB, but may be as low as 28 dB (25:1)	34 dB min. on most sensitive ranges, 28 dB min. on all other ranges	140 dB min. at dc; 120 dB min. at 60 Hz with no unbalance; 100 dB min. at 60 Hz with 5000 ohms unbalance	140 dB min. at dc; 120 dB min. at 60 Hz with no input unbalance; 100 dB min. at 60 Hz with 5000 ohms unbalance
Common mode or quadrature voltage	$\approx$ 40 V max. on 3 most sensitive ranges; $\approx$ 400 V max. on all other ranges	10x differential mode signal which causes 25 div deflection	$\approx$ 500 V max.	$\approx$ 200 V max.
Zero drift (time, temp., and volt variations)	0.5 div/10°C max. from 0 to 50°C; 0.1 div max. from 103 to 127 V	0.5 div/hr max., 2 div/24 hr max.; 0.5 div/10°C max. from 0 to 50°C; 0.1 div max. from 103 to 127 V	0.25 div/10°C max. from 0 to 50°C; 0.1 div max. from 103 to 127 V	0.25 div/10°C max. from 0 to 50°C; 0.1 div max. from 103 to 127 V
Gain stability (temp. and line volt variations)	1% max. from 0 to 50°C; 1% max. from 103 to 127 V	1% max. from 0 to 50°C; 1% max. from 103 to 127 V	1% max. from 0 to 50°C; 1% max. from 103 to 127 V	1% max. from 0 to 50°C; 1% max. from 103 to 127 V
Noise (max. p-p at calibrated gain)	0.1 div	0.1 div	0.25 div	0.5 div
Max. non-linearity	0.25 div	0.25 div	0.25 div	0.25 div
Internal calibration	1 V $\approx$ 1%	0.2 V $\approx$ 1%	10 mV $\approx$ 2%	0.2 mV $\approx$ 2%
Price	958-3600, \$2500	958-2900, \$2500	958-3400, \$3500	958-1500, \$3800

Frequency response for all systems: dc to 150 Hz (40 mm channels); dc to 125 Hz (50 mm channels); -3 dB, 10 div p-p; except 958-1500, which is dc to 100 Hz.



958-3600

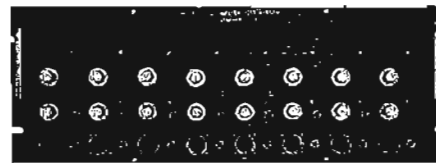

958-3400

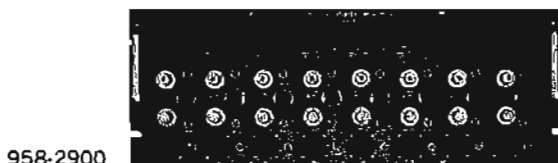

958-2900

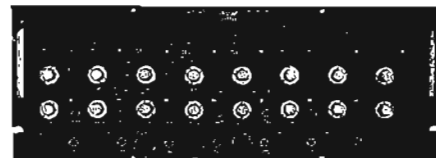

958-1500

# MULTICHANNEL AMPLIFIERS

Solid-state ampl/drivers for Optical Recorders  
650 Series for 4500 Optical System



## RECORDERS

Model	658-2000	658-2900	658-3400
Amplifier type	galvanometer driver, general-purpose	low-gain, general-purpose	medium-gain, general-purpose
Max. sensitivity	625 mV/in (5 V for 8" trace)	50 mV/in (400 mV for 8" trace)	2.5 mV/in (20 mV for 8" trace)
Attenuation range	X1, 2, 4, 10, 20, 40; smooth gain 2.5-to-1 adj.; up scale and down scale output switch; attenuation error = 2% max.	X1, 2, 5, 10, 20, 50, 100, 200, 500, 1000; smooth gain 2.5-to-1 adj.; attenuation error = 2% max.	X1, 2, 5, 10, 20, 50, 100, 200, 500, 1000, 2000, 5000; smooth gain 2.5-to-1 adj.; attenuation error = 3% max.
Input circuit	single ended, 100 k	bal. to gnd.; 1 megohm each side	floating and guarded, 100 k
Zero suppression	N/A	follows attenuator switch and pre-range	N/A
Common mode or quadrature rejection ratio	N/A	34 dB X1 range, 28 dB other ranges	140 dB at dc, 120 dB at 60 Hz bal., 110 dB at 60 Hz 1000 ohms unbal.
Common mode or quadrature voltage	N/A	= 2.5 V on X1 range, multiply att. range X2.5 to max. of = 500 V	= 500 volts
Frequency response (within 3 db point)	0 to 5 kHz (4" p-p) 0 to 3 kHz (8" p-p)	0 to 5 kHz (4" p-p) 0 to 3 kHz (8" p-p)	0 to 5 kHz (4" p-p) 0 to 3 kHz (8" p-p)
Response time (10% to 90%)	80 $\mu$ sec 4% or less overshoot	80 $\mu$ sec 4% or less overshoot	80 $\mu$ sec 4% or less overshoot
Zero drift (time, temp. and line voltage variations)	0.025"/10°C max., 0 to 50°C; 0.02" max., 103 to 127 volts	0.1"/10°C max., 0 to 50°C; 0.02" max., 103 to 127 V; 0.1"/hr.	0.05"/10°C max., 0 to 50°C; 0.02" max., 103 to 127 volts
Gain stability (temp. and line volt variations)	better than 1%, 0 to 50°C; better than 1%, 103 to 127 volts	better than 1%, 0 to 50°C; better than 1%, 103 to 127 volts	better than 1%, 0 to 50°C; better than 1%, 103 to 127 volts
Noise (max. p-p at calibrated gain)	0.02" p-p max.	0.02" p-p max.	0.02" p-p max.
Max. non-linearity	= 1.5% full scale (8")	= 1.5% full scale (8")	= 1.5% full scale (8")
Internal calibration	2.5 volts = 1%	0.2 volt = 1%	10 mV = 2%
Price	658-2000. \$2200	658-2900. \$2895	658-3400. \$3780
Price (with cooling fan)	(658-2000-Opt. 2) \$2345	(658-2900-Opt. 2) \$3040	(658-3400-Opt. 2) \$3925

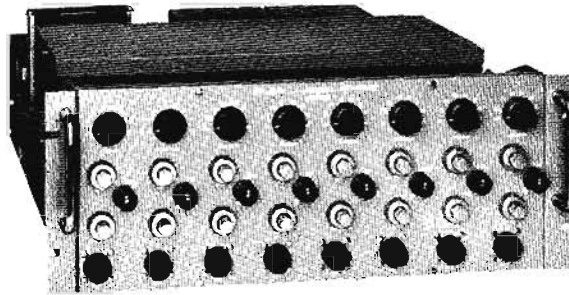

658-2000

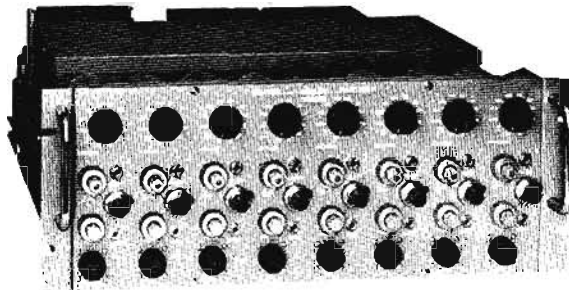

658-2900

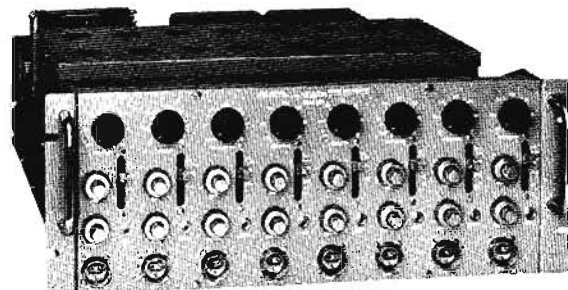

658-3400





## TRANSDUCERS

Sensors of linear motion, force, size and pressure  
Models 7LV, 585, 586, 270, FTA, 1281, DCDT, GT, 311-A

### Linear displacements

Linearsyn® (LVDT) Transducers produce an electrical output proportional to any physical parameter which is capable of conversion to a relative displacement between the transducer's core and coil assembly. A wide stock selection of transducers is available for a variety of industrial and laboratory applications. When used with Sanborn or equivalent carrier amplifiers, linear displacements to 0.000001" may be resolved. Non-linearity error will not exceed 1.0% of total stroke; temperature range, -50° to 205°F. Linearsyns are shielded, immersible in non-corrosive fluids without damage, resistant to shock and vibration and void of friction and mechanical hysteresis.

7DCDT and 24DCDT (DCLVDT) dc excited, dc output linear displacement ( $\pm 0.05"$  to  $\pm 3"$ ) transducers are extremely convenient to use for measuring, monitoring or controlling mechanical displacements. No external carrier system is required, and phase shift and balancing adjustments are not necessary. Each DCDT has a built-in carrier oscillator and phase-sensitive demodulator which produces a high-level dc output voltage proportional to the linear displacement of the core. Both series have extremely high resolution, zero hysteresis and non-linearity less than  $\pm 0.5\%$  of total stroke. The 24DCDT's have approximately three times the sensitivity of the 7DCDT's and operating temperature to 250°F (7DCDT, 140°F). Nominal excitation is 6 V dc, 20 milliamps for the 7DCDT series and 24 volt dc, 38 milliamps for the 24DCDT series. They should be energized from a low-impedance, well regulated power source such as the Model 6204A which provides excitation for several 7DCDT's or 24DCDT's. A 6.5 V battery-operated power supply, TPS-10, is available for 7DCDT's.

### Linear velocity

LVsyn® Linear Velocity Transducers are remarkably simple to set-up and use for sensitive measurements of relative velocity. The basic LVsyn design eliminates the need for external excitation. DC voltages are generated by moving a high flux density permanent magnet in the bore of differentially wound coils. The voltage amplitude is proportional to core velocity. Resolution of an LVsyn output is unlimited—sensitivity over the rated stroke range is constant within 5%—temperature range between -50°F to +200°F. They can be operated single-ended or push-pull; while immersed in non-corrosive fluids; without end stops or displacement limits. Each transducer is supplied with a calibration record.

### Dimensional gaging

GT Dimensional Gaging Transducers can be quickly set up to gage, classify or profile single or multiple-point machined dimensions in seconds. Pieces can be gaged to millionths repeatedly with these precision miniature differential transformer transducers that feature zero hysteresis, high resolution and linearity. Rugged GT's meet AGD mounting dimensions for dial indicators and operate from -50° to +170°F. Non-linearity is less than 1.0% of total stroke; contact pressure is 6 oz. max. and nominal carrier excitation is 6

volts at 2.4 kHz. These miniature GT gages have  $\frac{3}{8}$ " diameter stainless steel casing, replaceable contactor, precision bearings—terminations which will match Sanborn carrier amplifiers (GT-3-030-1), multiple gaging systems (GT-3-030-2); or with tinned leads only (GT-3-030).

### Low level forces

FTA low-level tension and compression sensing transducers ( $\pm 1$  to  $\pm 100$  gm) are ideal for measuring buoyancy, discrete weights, small bearing torques, displacements and angles, as well as muscle contractions and other physiological motion. These miniature "Micro-force" transducers provide an economical way to measure uni- or bi-directional forces with infinite resolution, linearity to 0.2% of full scale and hysteresis as low as 0.1% of applied force. FTA's have 400% overload capacity, low tracking force (no bearing friction) and excellent thermal stability over 0° to +170°F. Nominal excitation is 5 volts at 2.4 kHz.

### Gas pressure

The 270 is a highly sensitive and stable instrument for measuring low gas pressures. It was originally developed and is used in medical pulmonary studies but now, also is replacing the 14 inch water manometer in many industrial and laboratory applications such as missile and airborne pneumatic control testing, and leak detection in vacuum and pressurized systems. The 270 has the same inherent advantages as other Sanborn differential transformer transducers (LVDT's), in addition to a relatively high natural frequency, low volumetric displacement (0.003 cu in full scale), high sensitivity (28 mV/vex), temperature operating range between 32° and 120°F and ability to measure either single-ended or differential pressures. Ratings are based on carrier excitation of 5 volts at 2.4 kHz.

### Liquid or gas pressure

This new series of pressure transducers consists of five transducers with pressure capabilities of 15, 100, 300, 1000, and 3000 PSI. This new series is for use in industries such as aerospace, petroleum, chemical, hydraulics and others. The 1281 Series pressure sensors operate on a variable inductance bridge principle in conjunction with carrier amplifiers, and can be used with such recording systems as Models 301 and 321, 350 Series, 7700 Series, and 950 Series. Contact material is 17-4 stainless, and the housing and tube adapter is of nickel plated steel. The specified temperature range is -40°F to 250°F. They have 0.5% linearity, 8 mV/Vex sensitivity, and high overload protection, and can be used either flush-mounted or with tube adapters.

Model 1281-0A: 0-15 PSI; Model 1281-02A: 0-100 PSI; Model 1281-03A: 0-300 PSI; Model 1281-04A: 0-1000 PSI; Model 1281-05A: 0-3000 PSI. All units are 2.5" diameter by 3.8" high. Weight: approx. 24 ounces. Price: \$250.

### Optional accessory equipment

Model 311A Transducer Amplifier Indicator, \$425; DCDT Power Supplies Model TPS-10, 6.5 V dc (w/battery), \$42.

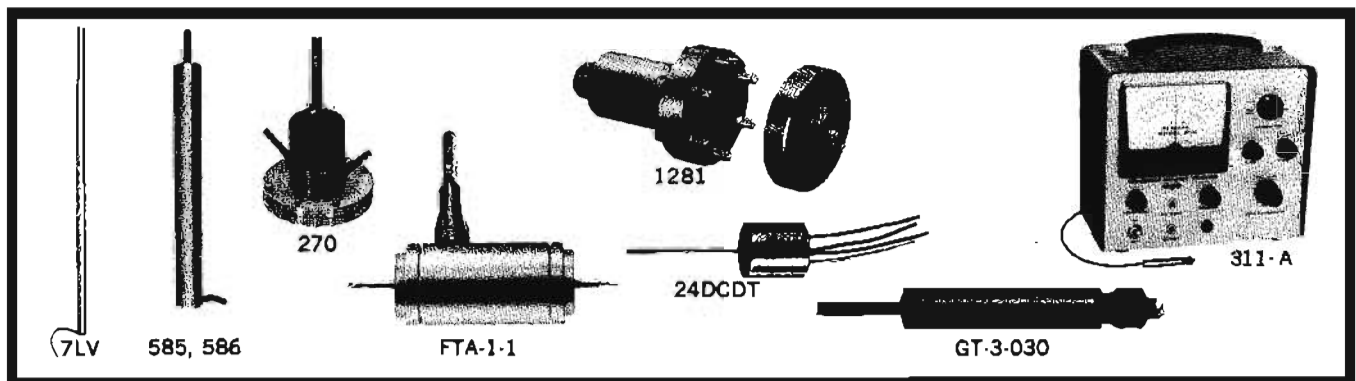

**Specifications, DCDT Transducers**

Model	Model 7DCDT/24DCDT					
	-050	-100	-250	-500	-1000	-3000
Stroke (range) (in)	±0.05	±0.1	±0.25	±0.5	±1	±3
Output, volts f.s.	7 DCDT 24 DCDT					
Output impedance	7 DCDT 24 DCDT					
Excitation (V dc)	7 DCDT 24 DCDT					
Dimensions, inches (mm)	7 DCDT 24 DCDT					
Weight (gm)	Armature Assembly					
Weight (gm)	net shipping					
Price	7 DCDT 24 DCDT					

**Specifications, Dimensional Gaging Transducers**

Model	GT-3-030	GT-3-030-1	GT-3-030-2
Displacement range* (in)	±0.03	±0.03	±0.03
Sensitivity (mV/0.3 in./vex at 2.4 kHz)	70	3±10%	Adjustable 2.6±1%
Impedance (ohms): input output	180 + j280 260 + j260	180 + j220 50	180 + j280 50
Phase shift (at 2.4 kHz)	20°	0°	0°
Dimensions	2.34" lg, 0.375" dia (59 x 10 mm)		
Weight (gm)	net 500	500 800	500 800
Price	\$115	\$140	\$170

\*Working range ±0.04", accuracy 1%; total mechanical stroke ±0.05".

**Specifications, Linearsyn Transducers**

Model	585DT**					688DT					695DT**		
	-050	-100	-250	-500	-1000	-050	-100	-250	-500	-1000	-005	-025	-100
Excitation frequency std: range:	2.4 kHz 400 Hz — 10 kHz					60 Hz 50 Hz — 400 Hz					2.4 kHz 400 Hz — 20 kHz		
Stroke range (inches)	0.05	0.1	0.25	0.5	1	0.05	0.1	0.25	0.5	1	0.005	0.025	0.1
Sensitivity* (V/in./vex)	4.8	3.1	1.7	1.1	0.79	1.2	1.2	1.5	1.1	0.8	2.2	3.4	2.7
Impedance* (ohms) primary: secondary:	163 2140	160 780	151 176	332 370	157 247	110 2340	81 820	90 890	47 2020	110 1800	93 154	303 365	330 365
Vex* (max)	21	27	17	25	30	9	8	18	7	11	5	11.5	13
Size— inches (mm) diameter: length:	0.75 (19) 1.63 (41)	0.75 (19) 1.94 (49)	0.75 (19) 3.31 (84)	0.75 (19) 4.88 (124)	0.75 (19) 6.88 (155)	0.75 (19) 1.63 (41)	0.75 (19) 1.94 (49)	0.75 (19) 3.31 (84)	0.75 (19) 4.88 (124)	0.75 (19) 6.88 (155)	0.375 (10) 0.90 (23)	0.375 (10) 1.09 (28)	0.375 (10) 1.09 (28)
Weight (gm) armature assembly	5	6	7	12	18	5	7	15	12	18	0.10	0.25	0.29
Weight (gm) net shipping	47 227	56 227	104 227	132 227	178 227	47 227	57 227	105 227	132 227	178 227	7.1 84	7.9 84	7.9 84
Price	\$25	\$35	\$41	\$50	\$60	\$25	\$35	\$41	\$50	\$60	\$30	\$27.50	\$35

\*At standard carrier frequency. \*\*For units supplied with 8' cable (w/connector and phasing unit) for direct operation with 2.4 Hz carrier amplifiers, add -BM to model number and \$30 to price.

**Specifications, LVsyn Transducers**

Model	3LVA6	3LV1	6LV1	8LV2	8LV3	8LV4	7LV6	7LV9	7LV20
Sensitivity (mV/in./sec)	120 40*	90 35*	500 250*	500 250*	500 250*	500 250*	350 150*	350 150*	20 7*
Resistance (k ohms)	2	2.5	13	19	25	32	11.5	17	3
Inductance (henrys)	0.085	0.065	1.6	2.4	3.2	4	1.9	2.8	0.035
Stroke range (mm)	0.5 (13)	1 (25)	1 (25)	2 (51)	3 (76)	4 (101)	6 (152)	9 (229)	20 (508)
Size— inches (mm) diameter: length:	0.37 (10) 3.16 (80)	0.37 (10) 4.22 (108)	0.63 (16) 5 (128)	0.63 (16) 7 (178)	0.63 (16) 9 (230)	0.63 (16) 11.25 (275)	0.75 (19) 15.75 (400)	0.75 (19) 22.75 (580)	0.75 (19) 30 (760)
Weight (gm) armature assembly	3.5	4.5	11	15	17	22	54	69	40
Weight (grams) net coil core shipping	20 84	25 84	110 224	150 252	200 308	240 336	420 505	610 756	800 900
Price	\$40	\$45	\$50	\$55	\$60	\$65	\$85	\$100	\$120

\*Output with non-breakable magnet cores (-N models); to order add suffix -N to basic model number, e.g., 3LVA5-N, 3LV1-N, etc. Prices same as standard models.

**Specifications, Microforce Transducers**

Model	FTA-1-1	FTA-10-1	FTA-100-1
Force (range, gm)	±1	±10	±100
Displacement (full scale, in)	±0.01	±0.01	±0.01
Sensitivity (full scale, mV/vex)	8	8	8
Natural freq (Hz)	65	130	390
Sensitivity (g) (% of f.s./g) radial: axial:	0 21	0 5	0 0.6
Dimensions inches (mm)	1.37 lg, 0.75 dia (35 x 19)		
Weight (gm) net shipping	FTA-X*, 90; FTA-X-1, 153 760		
Price	FTA-X*, \$175; FTA-X-1, \$200		

\*FTA transducers without adapter for operation with HP carrier systems; sensitivity ranges from 70 to 83 mV/vex at 2.4 kHz; X = range in grams.

**Specifications, Pressure (Gas) Transducer**

Model	270
Differential pressure range psi (mm H <sub>2</sub> O)	±0.5 (±350)
Common mode pressure psi (mm H <sub>2</sub> O)	3(2000)
Sensitivity (full scale) mV/0.5 psi/vex at 2.4 kHz	28 mV/vex
Linearity error (full scale)	less than 1%
Hysteresis (applied pressure)	less than 0.1%
Differential performance, (applied pres., equal inputs)	output less than 0.01%
Acceleration sensitivity	0.005 psi (3.5 mm H <sub>2</sub> O)/g
Dynamic response: square wave:	rise time, 5 ms; overshoot, 10%
sine wave: amplitude ratios:	0 — 20 Hz, flat to 1% 0 — 40 Hz, flat to 5%
diff. balance:	0 — 20 Hz, within 1%
Dimensions:	2.63" high, 2.75" dia (67 x 70 mm)
Weight:	net 1 lb (0.45 kg), shipping 2 lbs (0.9 kg)
Price:	Model 270, with 8-ft cable/adptr/conn. \$295



### Magnetic tape instrumentation

Magnetic tape recorders record electrical data which may range from dc to 1.5 MHz for later play-back, analysis, and evaluation. The data may already be in electrical form or may be an almost unlimited variety of physical or scientific phenomena converted to electrical form by a transducer.

Recording systems generally fall into one of two categories: analog or digital. Analog systems, with which we are concerned here, record electrical data in its original form, that is, as a continuous stream of variations in the input signal, which are continuously recorded on the tape. In digital systems, on the other hand, the input data are translated into a series of bits or pulses (generally in the binary code) for easy handling by digital computers and other digital processing systems. (See the Data Acquisition section for further information on digital techniques.)

Analog magnetic recorders can themselves be subdivided into a number of classes. These include the audio tape recorder (home recorders, dictation machines, etc.), video recorders (i.e., television recorders), and instrumentation recorders. The first two types of recorders are special-purpose in that they are designed for a specific application. Instrumentation recorders, however, are general-purpose instruments. Hewlett-Packard offers instrumentation magnetic recording systems of varying complexity to handle virtually all of the analog recording requirements of the industrial, medical, and chemical technologies.

### Advantages of magnetic recording

Magnetic recording is an economical, time-saving method of preserving data for analysis. Almost any phenomenon which can be converted to an electrical signal with an appropriate transducer can be recorded and then is available indefinitely for analysis, in electrical form. It is then easily compared to other data or studied alone by means of X-Y recorders, strip-chart recorders, oscilloscopes, wave analyzers, digitizing systems, or other analyzing equipment. Since

the material can be replayed over and over again, it may be analyzed several different ways.

By recording data on tape, the speed of events can be changed during play-back, either expanding or compressing time. Rapidly occurring events or high frequencies can be reproduced at slower tape speeds, for slow, detailed observation. The lowered reproduced frequencies can then be studied with convenient low-frequency equipment such as analyzers and chart recorders. On the other hand, slow events or low frequencies can be speeded up, scanned rapidly for significant content, by reproducing them at faster speeds than that used during the recording. This latter method is particularly important in shortening analysis time; slowly occurring phenomena can be greatly compressed in time, and analyzed quickly and conveniently on such higher frequency equipment as an oscilloscope.

One of the most important advantages of tape recording is its ability to monitor continuously, recording unexpected and/or unpredictable events. Thus, it can preserve irreplaceable data. Such data might include power line transients, seismic tremors, and atomic blast effects.

Continuous monitoring with magnetic recorders is economical. If no significant phenomenon occurs, the tape is simply erased and reused. With up to 14 channels, magnetic data recording systems can also preserve the time relationships among several rapidly occurring events. This capability is extremely important in analysis of cause and effect.

Magnetic recording has the further advantage that the recorded material is immediately available for reproduction. There is no delay for processing of the recorded material. On the other hand, tapes can be stored for long periods without degradation of the recorded material. Thus, events separated widely in time can be compared easily.

### The magnetic recording system

The magnetic recording system consists of three basic parts: the electronics, the head assembly, and the tape trans-

port. The electronics part of the system supplies the input data in proper form to the record head and recovers the data from the reproduce head.

The head assembly has both a record and a reproduce section. The record section impresses the input data onto the magnetic tape as variations in local magnetization; the reproduce section reconverts these variations back into electrical signals.

The tape transport drives the tape past the head assembly at a constant speed.

The magnetic tape while not an integral part of the recording system, is nevertheless extremely important in overall system operation. In some instances it is

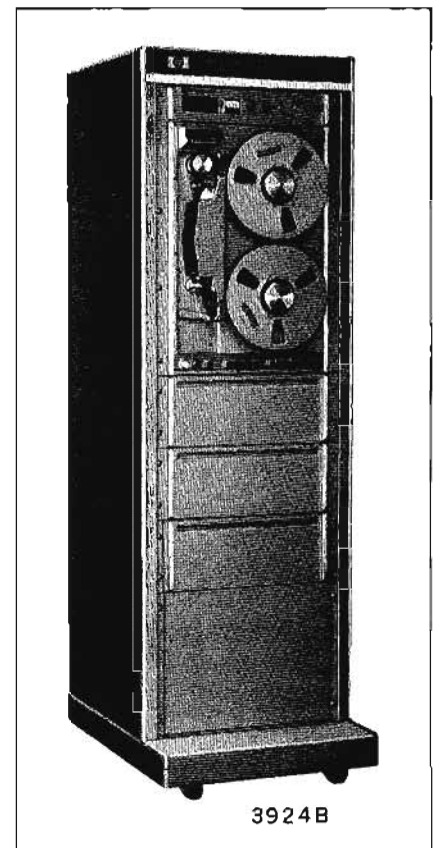

the tape which imposes the limitation on performance. Care in selecting tape to match recording requirements is well justified.

Magnetic tape consists of a layer of magnetic material laid down on a flexible base, usually of polyester film. The magnetic material is initially demagnetized. The recording heads are electromagnets which have a small gap in the core across

which the tape is moved. As the tape crosses this gap in the core, it acts as a magnetic shunt across the gap. When the tape is in motion, that part which leaves the trailing edge of the gap is left permanently magnetized in the direction of head magnetization at that instant. The intensity of magnetization is proportional to the instantaneous signal current in the head at the instant that portion of the tape left the gap.

The reproduce head is an electromagnet similar to the record head. When the magnetized tape particles are shunted across its gap a magnetic flux is developed in the core. As the tape moves, the variations in flux induce a voltage in the head winding proportional to the *rate of change* of the magnetic field in the gap. This voltage, with appropriate processing by the reproduce electronics, re-creates the original input signal.

### Recording methods

Two methods are commonly used to impress analog electrical data on the tape: Direct and FM. In the Direct recording process, the input signal is added linearly to a high frequency bias signal, and the combination is applied to the record head. The bias signal overcomes the non-linearity (common to all magnetic material) of the tape, with the result that the intensity of magnetization is proportional to the instantaneous amplitude of the input signal.

The advantage of the Direct record process is that it provides the greatest bandwidth obtainable from the recorder. It also requires only simple, moderately priced electronics. However, since a signal is induced in the reproduce head only when there are flux variations as the tape passes the head, the low frequency response of a Direct record system does not extend to dc. The Direct recording process also is characterized by some amplitude instability, caused by random surface inhomogeneities in the tape. At long wavelengths (lower frequencies) these amplitude variations may be only a few percent. However, for frequencies near the upper bandwidth limit for any given tape speed, amplitude variations can exceed 10%, and momentary decreases of over 50% (called "dropouts") are occasional.

Direct recording, then, is used when maximum bandwidth is required and amplitude variation errors are not critical. Typical applications of the Direct record process include sound recording, where

the ear averages amplitude variation errors, and carrier frequency recording. When maximum bandwidth must be obtained with relative freedom from dropouts, a single input signal can be recorded on several channels simultaneously.

Frequency modulation (FM) recording overcomes some of the basic limitations of direct recording at the cost of reducing high frequency response. Frequency response extends down to dc, and the reproduced signal is not significantly degraded by tape amplitude variation effects.

In the FM recording method, a carrier oscillator is frequency-modulated by the input signal. The center frequency corresponds to a zero-level input and the deviation from the center frequency is proportional to the amplitude of the input signal. The direction of the deviation is determined by the input signal polarity. In typical FM systems,  $\pm 40\%$  deviation of the carrier frequency corresponds to  $\pm$  full scale for the input signal. The FM recording process is used, then, when the dc component of the input signal is to be preserved, or when the amplitude variations of the Direct recording method cannot be tolerated.

While FM recording overcomes some limitations of the Direct method, it in turn has its own limitations. These are: (1) limited high frequency response com-

serve data for evaluation. This need occurs in medicine, environmental testing, nuclear and geological investigations, oceanography, aero-space experiments, etc.

In the field of medicine, for example, preserving a record of patient reaction to treatment is often extremely important. The multi-channel capability of magnetic recorders permits pulse, respiration, temperature, etc., all to be monitored and recorded simultaneously. Since time relationships are preserved, an entire chain of events can be reconstructed exactly as it happened.

During environmental testing, a number of parameters are usually monitored. Stress and strain caused by shock and vibration are two. Of course, general device operation during extremes of temperature, pressure, and humidity are also monitored. Magnetic recorders can preserve all of this data.

Predetection recording of telemetered data is another important application for magnetic tape recorders. As its name implies, predetection recording preserves the data in its transmitted form. The best method of detection can then be determined by experiment *after the fact*, with minimum possible loss of information.

These are but a few of the applications for which analog magnetic recording is

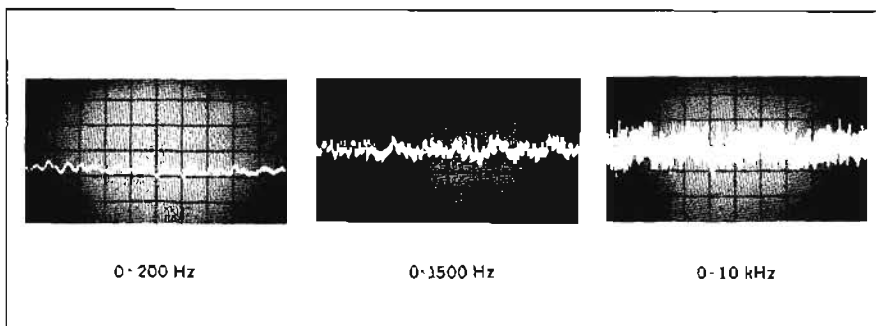

Typical Low Flutter of Hewlett-Packard Transport  
Bandwidth used for measurement is shown in each case.  
Vertical scale is 0.2% p-p per cm. Tape speed is 60 ips.

pared to the Direct process, (2) dependence on the instantaneous tape velocity, and (3) electronics which are somewhat more complex and, therefore, somewhat more costly.

### Applications

Magnetic recorders have application in any field in which there is need to pre-

served. The total number is constantly expanding.

### Design philosophy

The objective sought during the design of the Hewlett-Packard magnetic tape recording systems was to provide a high-performance system with a simplicity of design that assures easy operation and high day-to-day reliability. The level of



performance which has been achieved, performance which is measured in terms of the smoothness of tape motion—i.e., low flutter and wow—is attested by the oscillograms shown above. At the same time, to assure reliability, the tape transport is designed so that *it requires no maintenance* other than occasional cleaning to remove tape oxide dust.

In addition to designing for simplicity in the transport, and also in the electronics, the elements of the tape system were designed for economical production. Consequently, the cost of Hewlett-Packard tape systems is considerably lower than that of other systems of comparable performance.

### Choosing an HP tape recorder

The Hewlett-Packard line of Instrumentation Tape Recording Systems includes ten basic systems, listed in Table I. As shown, five have 7-track capability and the other five have 14-track capability.

The ten systems were derived from two basic transport mechanisms. One transport was designed for a maximum reel size of 15 inches, which permits longest playing time. The other transport accommodates reels up to 10½ inches and thereby achieves a more compact configuration. Each of the two transports comes in two versions, one for ½ inch wide tape for recording seven channels of information, and the other designed for 1-inch tape to permit 14-channel recording.

The other differences among the various systems are in the head assemblies and the electronics. All of the Hewlett-Packard tape systems conform to IRIG (Inter-Range Instrumentation Group) specifications with regard to track width, track spacing, FM carrier frequencies, and FM deviation. The tape records are interchangeable with other machines adhering to IRIG standards.

The ten systems may be grouped into three categories, according to bandwidth capabilities. The first group provides Direct recording to 100 kHz, or FM recording to 10 kHz. The second group provides Direct recording beyond 250

kHz and FM recording to 20 kHz. The third group achieves an upper frequency limit of 1.5 MHz in Direct recording and 400 kHz in FM recording.

The systems may also be grouped according to electronic design (all of the Hewlett-Packard Magnetic Tape Recording Systems use solid-state circuits). The first in this grouping includes the Models 3907B through 3924B systems, as listed in Table I. These systems have the record and reproduce electronics on circuit cards that plug into the electronics cabinet. Both record and reproduce circuits for each channel are mounted on a single card (preamplifiers for the reproduce heads, in either Direct or FM recording, are permanently mounted on the transport chassis). The tape-speed networks are on separate sub-module cards that plug onto the amplifier cards, thus making a change to another tape speed a matter of changing only the tape-speed sub-modules.

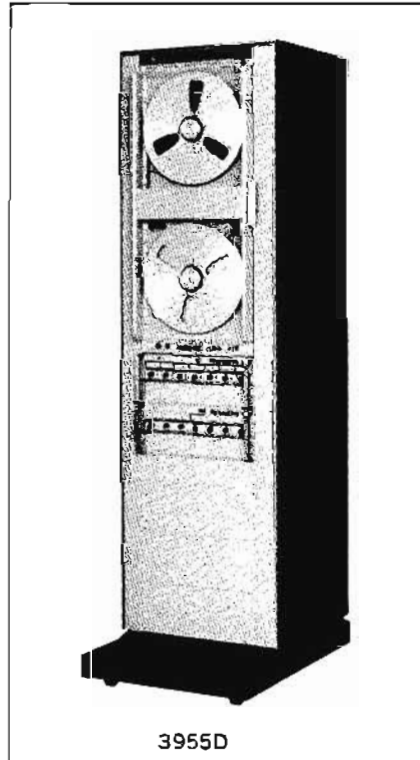

3955D

These systems obtain superior performance at lowest cost. They are also most compact; a 7-channel system requires only one electronics mainframe and a 14-channel system requires only two. These

systems are supplied either in standard cabinet racks or in portable cases.

The second group consists of the four systems in the 3955 Series. These four systems have greater flexibility, in that separate modules are used for the record and reproduce electronics. Furthermore, each module holds three tape-speed networks at a time, any one of which is selected by pressing the appropriate push-bar on the module's front panel. Speed changes are quickly effected with the push-bar technique used in these systems.

The 3955 systems also have monitor meters to indicate the input signal levels. Front panel switches allow the meter to monitor the bias on each track. Push-buttons allow test signals to be inserted conveniently on any track, requiring access only to the front panel.

The reproduce preamplifiers of the 3955 systems use a new input circuit,

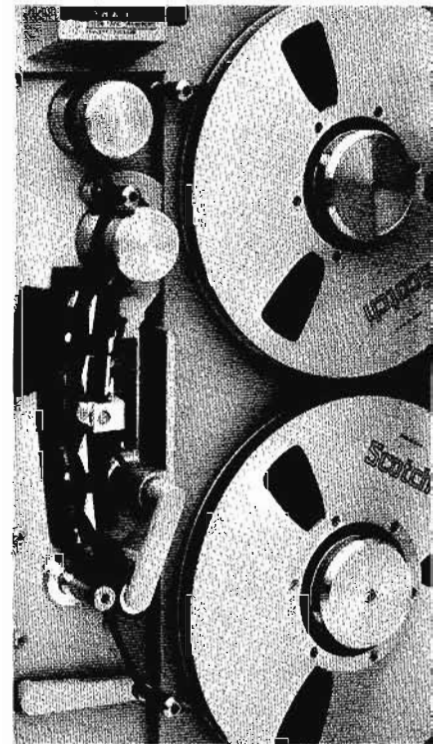

Straightforward open-loop tape drive on Hewlett-Packard transports.

which evolved from other developments in magnetics in the Hewlett-Packard Laboratories, achieving outstanding signal-to-noise performance.

The four systems in the 3955 Series differ only with respect to the transport, since the same electronics modules are used in all four systems. There is a choice of 7-channel or 14-channel systems and a choice of maximum reel size. Systems using the transports with 10½ inch reels are the most compact and inexpensive. The 15-inch transports provide the longest recording time (up to 19 hours at a tape speed of 1⅞ ips).

The third group, intended especially for wide band recording, are the 3950 systems. These provide Direct record bandwidths to 1.5 MHz and FM to 400 kHz. The 3950 systems achieve higher tape packing density, and hence higher frequency response at a given tape speed, than the other systems. The 3950 systems have a maximum tape speed of 120 ips and are therefore supplied only with the 15-inch reel transport to allow over 17 minutes of recording time at 120 ips.

Many of the components of the 3950 systems are common to the 3955 systems.

### Transport mechanism

The key to obtaining quality performance at moderate cost in the Hewlett-Packard systems lies in the design of the

basic transport mechanism. The Hewlett-Packard transports achieve high quality performance, particularly evidenced by their low flutter and wow, with a rugged, uncomplicated mechanism. They have the further advantage of requiring no maintenance whatever, except for occasional cleaning of the heads and tape guides.

High performance was achieved with an open-loop-drive system (capstan contacts tape at only one point). Each element along the tape path was designed to contribute toward uniform tape movement past the recording and reproduce heads. A high degree of mechanical filtering is applied, in the form of viscous-damped fly-wheels and controlled frictional elements. The transport mechanism achieves performance comparable to all but the most costly closed-loop systems, in which the tape contacts the capstan at both exit and entry points of the head area. It does so without the use of complex tape drive systems.

The tape mechanism treats the recording tape gently, to insure no loss of data from tape stretching, tearing, or other accidents. The brake design uses fail-safe, mechanical negative feedback to insure optimum braking torque on each reel, regardless of the direction of tape move-

ment, thereby obtaining fast, smooth stops without tape spillage, stretching, or breaking.

The transport has six speeds, any one of which is selected simply by depressing the appropriate pushbutton. No capstan or belt changes are required. The tape is easily threaded, and the reel hub design enables one-handed mounting of the reels.

The tape transports also include a reliable tape footage counter. The tape footage counter has consistently demonstrated accuracy within a few inches on repeated high speed end-to-end shuttlings of a reel of tape, equivalent to an accuracy of 0.05%.

### Accessories

Several accessories are available for Hewlett-Packard Tape Recording Systems. One of these, the Model 3680A AC Power Supply, can be used to supply crystal-controlled 60-Hz power to the transport if the local power line frequency stability is considered unsatisfactory.

If even better timing accuracy than that provided by the basic transport is required, the Model 3681A Tapespeed Servo unit may be used with the AC Power Supply to maintain the playback speed the same as the record speed. The Tapespeed Servo provides standard IRIG speed control signals for recording on the tape during data recording. On playback, the speed control signal, by way of the Tapespeed Servo unit, controls the 60-Hz output of the AC Power Supply.

Instrumentation recorders normally do not have erase heads, to insure that valuable data is not lost because of accidental erasure. The tape is erased by external equipment, such as the HP Model 3603A Automatic Tape Degausser. The Automatic Tape Degausser achieves thorough erasure of tape without introducing any magnetic transients or other disturbances into the tape. This instrument accepts reels up to 15 inches in diameter and 1 inch in width and automatically erases the tape, independently of operator attention.

Also available are remote control boxes (Model 3907-11A) and a Voice Channel Amplifier. The Voice Channel Amplifier, Model 3604A, records and plays back voice commentary on the edge of the tape (for all systems but the 3950 Series).

Model	Tracks	Max. tape speed	Max. reel size "	Direct record max. BW	S/N dB	FM record max. BW	S/N dB	Page #
3907B	7	60	10½	100 Hz-100 kHz	40	DC-10 kHz	45	150-154
3914B	14	60	10½	100 Hz-100 kHz	40	DC-10 kHz	45	150-154
3917B	7	60	10½	300 Hz-250 kHz	35	DC-20 kHz	45	150-154
3924B	14	60	10½	300 Hz-250 kHz	35	DC-20 kHz	45	150-154
3955A	14	60	15	300 Hz-300 kHz	40	DC-20 kHz	48	155-160
3955B	7	60	15	300 Hz-300 kHz	40	DC-20 kHz	48	155-160
3955C	14	60	10½	300 Hz-300 kHz	40	DC-20 kHz	48	155-160
3955D	7	60	10½	300 Hz-300 kHz	40	DC-20 kHz	48	155-160
3950A	14	120	15	400 Hz-1.5 MHz	30	DC-400 kHz	30	155-160
3950B	7	120	15	400 Hz-1.5 MHz	30	DC-400 kHz	30	155-160

Table 1. Hewlett-Packard Magnetic Tape Recording Systems.



## RECORDERS



## MAGNETIC TAPE RECORDERS

Low-cost, instrumentation-quality recording

Models 3907B, 3914B, 3917B, 3924B

### Advantages:

- 50 to 100,000 c/s (Hz) bandwidth (Direct mode)
- DC to 10,000 c/s (Hz) bandwidth (FM mode)
- Six pushbutton speeds,  $1\frac{7}{8}$  to 60 ips, no capstan changes
- 40 dB or better signal-to-noise ratios
- 0.2% p-p flutter, 0 to 200 Hz at 30 and 60 ips
- IRIG compatibility
- 7 or 14 channels plus monitoring track

### Uses:

- Industrial: telemetry; flight, jet and missile engine, scientific laboratory tests; vibration studies, research; "back-up" or prime monitors in large process and test installations
- Medical: physiological, biological research; instruction

### Narrowband bandwidth 3907B, 3914B

Model 3907B, 3914B 7- and 14-channel magnetic tape recorders are excellent, accurate, low-cost systems for both industrial and medical applications. Complex recording requirements of IRIG telemetry and neuro-physiology can be handled easily with either system. Both systems are identical except for channel capacity.

Frequency response at 60 ips is 100 Hz to 100 kHz, Direct mode; dc to 10 kHz, FM mode. Their wide speed range  $1\frac{7}{8}$ ,  $3\frac{3}{4}$ ,  $7\frac{1}{2}$ , 15, 30 and 60 ips is particularly useful when time base expansion or contraction is needed, as it often is, for data analysis.

### Low-flutter tape transport

The superior performance of these tape recorders is largely due to the unique tape transport that is rugged yet simple in design. They compete in basic characteristics (flutter, s/n ratio, etc.) with the better servo-controlled systems. The transport incorporates the most advanced, simple, direct damping techniques known to minimize flutter, providing as low as 0.2% p-p flutter over 0 to 200 Hz bandwidth at 30 and 60 ips. The heads also provide extremely low cross-talk levels, which is highly desirable when Direct and FM channels are mixed on the same head stack, and the high output results in excellent Direct record signal-to-noise ratios. All models have an additional edge track for voice commentaries, or pulsed or time-coded data. The tape guide system will accept any standard recording tape on  $10\frac{1}{2}$ " reels. Other important elements of this carefully designed transport are a built-in footage counter accurate to 99.95%; a very simple snap-on reel holder mechanism, and single-side drive provides for simple tape threading. All speeds selected electrically by front-panel pushbuttons, which apply voltage directly to the proper winding of one of three dual-winding drive motors, and the same capstan and idler serve all tape speeds.

### Interchangeable electronics

Three modes of operation make 3907B, 3914B very versatile and flexible recording instruments. Interchangeable FM, Direct and Pulse record/reproduce inserts, with all solid-state electronics, plug into the insert rack and transfer chassis below the transport on the front panel (two racks are used in the 14-channel 3914B). The electronics can be all alike or mixed as required. Frequency compensation for any of the six speeds is available through small plug-in circuits that attach to the FM and Direct reproduce electronics in the inserts... frequency compensation is not required with Pulse record/reproduce inserts. (The individual reproduce preamplification for each channel is provided through a preamplifier card near the head assembly.)

### Time scale expansion/reduction

In addition to their ability to cover accurately a broad range of frequency response requirements, 3900 Recorders' wide speed range can be used to increase or decrease the record/reproduce time scale to a maximum of 32:1 to make data analysis more convenient. For instance, a 10 Hz signal recorded at  $1\frac{7}{8}$  ips would appear as 320 Hz played back at 60 ips increasing the scanning rate 32 times. Conversely, a 320 Hz signal recorded at 60 ips could be played back as a 10 Hz signal at  $1\frac{7}{8}$  ips into any Sanborn heated stylus recorder for a permanent record and immediate analysis (see pages 120-130). Fourteen channels of Direct mode taped data, as high in frequency as 100 kHz, can be played back at reduced speeds and immediately read out by traces greater than 4" p-p on a Model 4500 optical, multi-channel recorder (see pages 134-135) which has 0 to 5 kHz frequency response 3 dB down. Other readout methods such as Model 5601A multi-channel numerical display which is capable of driving HP 562A Digital Recorder (printout) can be used directly with HP magnetic tape recorders.

Other combinations of input and readout equipment are compatible with the 3900 Series Instrumentation Tape Recorders; for more data call your local HP sales office.

### Optional operating accessories

The versatile 3907B and 3914B may be operated at remote locations through Model 3907-11A Remote Control Panel(s) that include all functions: stop, play, reverse, fast, forward and record; and Model 3907-06A Voice Channel Amplifier can be added to the cabinet when it is desirable to record commentaries at the same time that data is being recorded; edge tracks are standard in all transports. Single-ended signals can be connected directly to these recorders, or Model 3907-07A Input Signal Coupler may be used to adapt push-pull output to the signal-ended input to the 3900 Systems. Tape Adapters (3907-04B for  $\frac{1}{2}$ " tape, 3914-04B for 1" tape) are capable of repetitive playback of tape loops up to 100 feet long.



### A complete system

A complete system includes the multi-track tape transport, insert rack(s) and transfer chassis, preamplifier rack, power supply, 7 or 14 reproduce preamplifiers and the cabinet. Record/reproduce electronics can be purchased for FM, Direct or Pulse operation in any combination, with speed equalization plug-ins for the speeds at which you wish to record. In Pulse mode plug-ins are not required.

### 3917B/3924B Intermediate Bandwidth Recorders

New Sanborn 3917B, 3924B intermediate bandwidth 7-

and 14-channel magnetic tape systems will record and store information with bandwidths to 250 kHz maximum on Direct mode and to 20 kHz max. in FM mode. These broadband recorders permit the use of lower tape speeds for most data recording purposes or as much as 2.5 to 1 increase over narrowband systems in the quantity of data stored for the same operating speed. Model 3900-12B Direct and 3900-13B FM Record/Reproduce broadband amplifier inserts and compatible speed equalization plug-ins (see page 154) are required—the reproduce preamplifier in these recorders has an additional stage for the higher gain/bandpass product requirements.

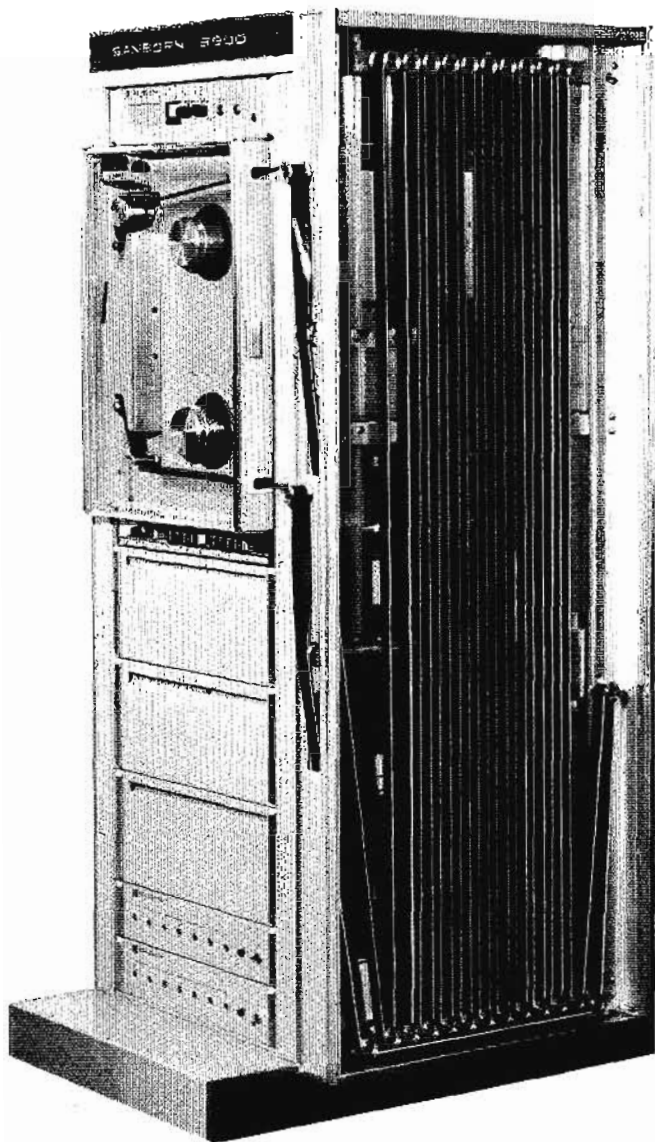

3907-04B Tape Loop Adapter

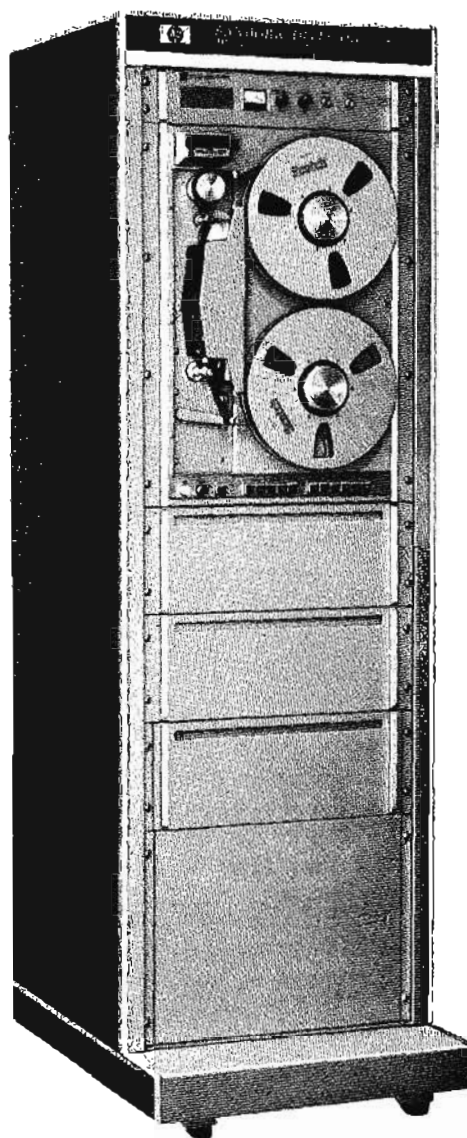

3900 Series Vertical Mobile Cabinet



## MAGNETIC TAPE RECORDERS CONTINUED

Low-cost, instrumentation-quality recording  
Models 3907B, 3914B, 3917B, 3924B

### System features

The electronics in the 3900 Recorders can be conveniently and simply aligned, as well as interchanged between FM and Direct or Pulse modes of operation at the front panel. The insert rack and transfer chassis, located directly below the tape transport, contain the power supply and accommodate seven printed circuit card record/reproduce amplifier inserts with plug-in speed equalization circuits. An eighth position is reserved for recording systems that have provision for voice commentaries through an edge track on the heads. Direct record/reproduce amplifier inserts (with speed equalization plug-ins) are required for voice channels. The reproduce amplifiers on the record/reproduce inserts for each channel are subdivided into three sections—preamplifier (fixed), main amplifier on record/reproduce inserts (interchangeable FM, Direct or Pulse) and plug-in circuits which determine the system gain, (Direct) or frequency (FM) for all tape speeds. The preamplifier design assures high signal-to-noise ratios.

The all solid-state power supply on the insert rack and transfer chassis delivers regulated operating voltages to all of the electronics in the recorder. Supply voltages can be measured at test points on the front panel and a built-in alignment meter and channel selector switch make setting the center frequency and modulation sensitivity of each FM channel a simple procedure.

When it is desirable to cancel the small amount of noise introduced by transport flutter in FM operation (see speci-

fications on page 153) channel 3 (and/or 10 in 14-channel systems) can be reserved to record and play back an unmodulated carrier signal which helps to cancel the noise in the output in any of the other channels. Placing the compensation switch "on" in the rear of the insert rack and transfer chassis applies a negative feedback signal to the output of each of the other channels, effectively cancelling the flutter signal and increasing the signal-to-noise ratio over the bandwidth on all tape speeds.

### Specifications, Tape Transport

(all models, unless otherwise specified)

- Number of tracks:** 7 (3907B, 3917B); 14 (3914B, 3924B).
- Track width:** 0.05".
- Track spacing:** 0.07" center-to-center.
- Max. interchannel time displacement error:**  $\pm 1 \mu\text{sec}$  at 60 ips, between two adjacent tracks on same head.
- Tape speeds:** 60, 30, 15,  $7\frac{1}{2}$ ,  $3\frac{3}{4}$ ,  $1\frac{7}{8}$  inches per sec.
- Tape width:**  $\frac{1}{2}$ " (3907B, 3917B); 1" (3914B, 3924B).
- Tape thickness:** 1 mil.
- Tape length:** 3600 feet, 1 mil tape.
- Reel size:** 10 $\frac{1}{2}$ " phenolic hub type.
- Start time:** approx. 4 sec. max.
- Stop time:** 1 second max.
- Rewind time:** approx. 150 seconds (3600 feet).
- Operating controls:** Line (Power), Stop, Play, Reverse, Forward (Fast), Record, are pushbutton relays; receptacle at the rear of the transport is provided for remote control operation.

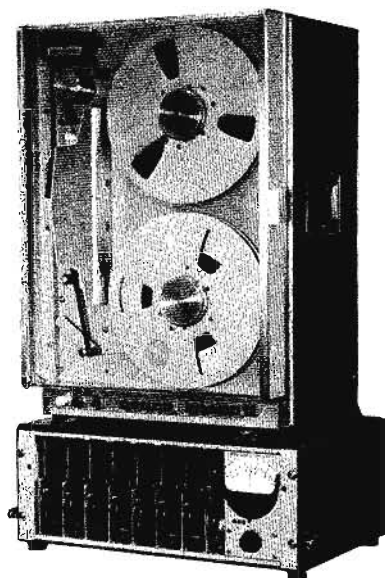

3907B Option 02  
Portable Cases for  
Transport and Amplifier

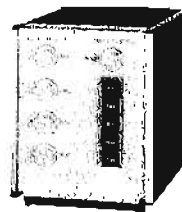

3907A-11A  
Remote  
Control  
Unit

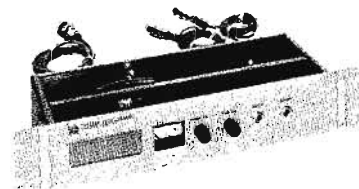

3907-06A  
Voice Channel  
Amplifier

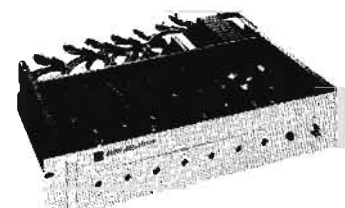

3907A-07A  
Input Coupling  
Amplifier

**Drive speed accuracy:**  $\pm 0.25\%$  of nominal capstan speed with 60 Hz line; speed is directly proportional to line frequency.

Speed	Bandwidth	Flutter (p-p)
60 ips	0 to 200 c/s (Hz)	0.2%
	0 to 1.5 kc/s (kHz)	0.3%
	0 to 10 kc/s (kHz)	0.6%
30 ips	0 to 200 c/s (Hz)	0.2%
	0 to 1.5 kc/s (kHz)	0.5%
	0 to 5 kc/s (kHz)	0.8%
15 ips	0 to 200 c/s (Hz)	0.25%
	0 to 1.5 kc/s (kHz)	0.45%
	0 to 2.5 kc/s (kHz)	0.6%
7½ ips	0 to 200 c/s (Hz)	0.4%
	0 to 1.25 kc/s (kHz)	0.65%
3¾ ips	0 to 200 c/s (Hz)	0.5%
	0 to 625 c/s (Hz)	0.8%
1½ ips	0 to 200 c/s (Hz)	0.8%
	0 to 132 c/s (Hz)	1.2%
	0 to 625 c/s (Hz)	1.5%

### Specifications, 3907B, 3914B Direct Record/Reproduce mode

**Record amplifier input:** 20,000 ohms resistance, single-ended; 0.5 to 10 volts rms, adjustable.

**Reproduce amplifier output:** single-ended; 1 V rms to 2.1 V rms at  $\pm 3$  mA, 100-ohm max. source impedance; dc level adjustable  $\pm 1.5$  V.

**Third harmonic distortion:** typical, 1% at 1 kHz, 60 ips.

**Direct, standard bandwidth**

Tape speed	Bandwidth c/s (Hz)	Frequency response (dB)	S/N ratio minimum rate* (dB)
60 ips	100-100,000	$\pm 3$	40
	300-70,000		45
30 ips	100-50,000	$\pm 3$	42
	300-35,000		47
15 ips	50-25,000	$\pm 3$	40
	300-18,000		47
7½ ips	50-12,000	$\pm 3$	40
	300-7,200		47
3¾ ips	50-6,250	$\pm 3$	40
	300-3,800		47
1½ ips	50-3,125	$\pm 3$	40
	300-2,200		45

\*Measured with bandpass filter at output with an 18 dB/octave rolloff.

### FM Record/Reproduce mode

**Record amplifier input:** 20 k impedance, single-ended;  $\pm 2.5$  volts dc (nominal), adjustable  $\pm 1.2$  to  $\pm 3$  volts dc.

**Reproduce amplifier output:** single-ended;  $\pm 2.5$  volts dc (nominal) at  $\pm 3$  mA max. adjustable  $\pm 1.2$  to  $\pm 5$  volts dc; 100 ohms max. source impedance; dc position adjustable  $\pm 2$  volts.

**Drift:**  $\pm 0.25\%$  max. for 10°C change, 15° to 35°C;  $\pm 0.25\%$  max. for 10 volt change in line voltage.

**FM, standard bandwidth**

Tape speed	Bandwidth	Frequency response (dB)	FM center carrier frequency (nominal) c/s (kHz)	S/N ratio*		Total harmonic distortion
				without flutter comp. (dB)	with flutter comp.** (dB)	
60 ips	0-10 kc/s (kHz)	+0, -1	54 c/s (kHz)	45	48	1.2%
30 ips	0-5 kc/s (kHz)	+0, -1	27 c/s (kHz)	45	49	1.2%
15 ips	0-2500 c/s (Hz)	+0, -1	13.5 c/s (kHz)	45	49	1.2%
7½ ips	0-1250 c/s (Hz)	+0, -1	6.75 c/s (kHz)	42	47	1.5%
3¾ ips	0-625 c/s (Hz)	+0, -1	3.38 c/s (kHz)	42	47	1.5%
1½ ips	0-312 c/s (Hz)	+0, -1	1.69 c/s (kHz)	40	41	1.9%

\*Over bandwidth, min. rms at zero frequency deviation measured with low-pass filter at output with an 18 dB/octave rolloff.

\*\*Channel 3 and/or 10 provide flutter compensators.

### Specifications, 3917B, 3924B Direct Record/Reproduce mode

**Record amplifier input:** 20,000 ohm resistance, single-ended; 0.5 to 10 volts rms, adjustable.

**Record amplifier output:** single-ended; 1 volt rms to 2.1

volts rms at  $\pm 3$  mA; 100-ohms max. source impedance; dc level adjustable  $\pm 1.5$  volts.

**Third harmonic distortion:** typical, 1% at 500 c/s (Hz), 30 ips.

**Direct, extended bandwidth**

Tape speed (ips)	Bandwidth c/s (kHz)	Frequency response (dB)	S/N ratio (fltered)* (dB)	Minimum rms unfltered (dB)
60	300-250	$\pm 3$	35	28
	300-175		36	
30	150-125	$\pm 3$	33	28
	300-88		36	
15	100-62.5	$\pm 3$	32	27
	300-44		38	
7½	50-31.25	$\pm 3$	30	26
	300-22		39	
3¾	50-15.6	$\pm 3$	30	26
	300-11		39	
1½	50-7	$\pm 3$	30	26
	300-5		39	

\*Measured with bandpass filter at output with an 18 dB octave rolloff.

### FM Record/Reproduce mode

**Record amplifier input:** 20,000 ohms impedance, single-ended;  $\pm 2.5$  volts dc (nominal), adjustable  $\pm 1.2$  to  $\pm 3$  volts dc.

**Reproduce amplifier output:** single-ended;  $\pm 2.5$  volts dc (nominal) at  $\pm 3$  mA max., adjustable  $\pm 1.2$  to 5 volts dc; 100-ohms max. source impedance; dc position adjustable  $\pm 2$  volts dc for positioning optical or direct-writing galvanometers.

**Drift:**  $\pm 0.25\%$  max. for 10°C change, 15° to 35°C;  $\pm 0.25\%$  max. for 10 volt change in line voltage.

**Linearity:**  $\pm 1.5\%$  of full scale, maximum deviation from a straight line using 0% and plus 30% frequency deviation as reference points.

**FM, extended bandwidth**

Tape speed	Bandwidth	Frequency response (dB)	FM center carrier frequency (nominal) kHz	S/N ratio* without flutter comp. (dB)	Total harmonic distortion
60 ips	0-20 kc/s (kHz)	+0, -1	108	45	1.5%
30 ips	0-10 kc/s (kHz)	+0, -1	54	45	1.5%
15 ips	0-5 kc/s (kHz)	+0, -1	27	45	1.5%
7½ ips	0-2500 c/s (Hz)	+0, -1	13.5	44	1.5%
3¾ ips	0-1250 c/s (Hz)	+0, -1	6.75	42	1.5%
1½ ips	0-625 c/s (Hz)	+0, -1	3.38	40	1.9%

\*Over bandwidth, min. rms at zero frequency deviation measured with low-pass filter at output with an 18 dB/octave rolloff.

### Specifications, 3907B, 3914B (3917B, 3924B)

#### Pulse Record/Reproduce mode

**Record amplifier input:** rectangular, zero-based negative-going pulse, -7.5 to -30 volts final amplitude; rise and fall times are not important except when they influence timing of recorded signal. There is no upper limit on pulse duration.

**Reproduce amplifier output:** rectangular zero-based negative-going pulse approximately -11.8 volts final amplitude across open circuit; output signal amplitudes, and rise and fall times are not related to input signals except as noted above.

**Output source resistance:** single-ended, 1000 ohms; may be loaded. For example, with 1000 ohm load approx. 6 V is available.

**Pulse, standard bandwidths**

Record and playback rate	Max. rise time (micro-sec)	Min. input pulse for output pulse accuracy (duration) (µsec)	Accuracy of pulse reproduction (µsec)	Typ. min. input pulse for any output (µsec)
60 ips	4 (3)	50 (25)	$\pm 5$ ( $\pm 10$ )	10 (2)
30 ips	4 (3)	100 (50)	$\pm 10$ ( $\pm 15$ )	15 (2)
15 ips	5 (3)	200 (100)	$\pm 20$ ( $\pm 20$ )	25 (2)
7½ ips	10 (5)	400 (200)	$\pm 40$ ( $\pm 25$ )	35 (3)
3¾ ips	20 (10)	800 (400)	$\pm 80$ ( $\pm 50$ )	50 (4)
1½ ips	40 (20)	1600 (800)	$\pm 160$ ( $\pm 150$ )	70 (6)

# RECORDERS



## MAGNETIC TAPE RECORDERS CONTINUED

Low-cost, instrumentation-quality recording

Models 3907B, 3914B, 3917B, 3924B

### Specifications, all models

**Power:** 115 volts  $\pm 10\%$ , 60 Hz  $\pm 2\%$ ; approximately 500 watts.

**Dimensions:** in mobile cabinet: 57 $\frac{3}{4}$ " high, 22" wide, 26" deep (1368 x 559 x 660 mm); rack mount Option 01: 24-15/32" high, 19" wide, 14" deep (622 x 483 x 356 mm) transport; 7" high, 19" wide, 13 $\frac{7}{8}$ " deep (178 x 483 x 352 mm) insert rack and transfer chassis; portable cabinets Option 02: 25" high, 16 $\frac{3}{4}$ " wide, 15 $\frac{3}{4}$ " deep (638 x 425 x 400 mm) transport; 7-9/16" high, 19 $\frac{5}{8}$ " wide, 14 $\frac{1}{2}$ " deep (192 x 500 x 368 mm) insert rack and transfer chassis; 3907-04B, 3914-04B, 1/2" and 1" Tape Loop Adapters fit on left side of cabinet.

### Weight (approx.)

**Model 3907B, 3917B:** net 456 lbs (180,4 kg), shipping 552 lbs (250 kg); rack mount Option 01: net 250 lbs (113,5 kg), shipping 350 lbs (159 kg) transport; net 100 lbs (45 kg), shipping 150 lbs (68 kg); insert rack and transfer chassis; portable carrying cases Option 02: net 300 lbs (136 kg), shipping 400 lbs (45 kg) transport; net 136 lbs (100 kg), shipping 150 lbs (68 kg) insert rack and transfer chassis.

**Model 3914B, 3924B:** net 500 lbs (227 kg), shipping 621 lbs (272 kg); rack mount Option 01: net 250 lbs (113,5 kg), shipping 325 lbs (157,5 kg) transport; net 100 lbs (45 kg), shipping 150 lbs (68 kg) insert racks and transfer chassis; portable carrying cases Option 02: net 100 lbs (45 kg), shipping 150 lbs (68 kg) transport; net 35 lbs (15,9 kg), shipping 45 lbs (20,4 kg) insert racks and transfer chassis.

**Optional accessory equipment:** 3907-07A Input Signal Coupler, less input cards, \$395 (adapts equipment with push-pull output to single-ended input of 3900); 3907-11A Remote Control Panel, \$385; 3907-06A Voice Channel Amplifier (includes microphone), \$250; can be used with Options 01 and 02 which have edge tracks in heads for voice commentaries but which require one 3900-10A Reproduce Preamplifier, \$41, one 3900-12A Direct Record/Reproduce Insert, \$158 or 3900-12B, \$173; and one 3907-04A Direct Equalization Plug-in (see prices below) for the eighth channel, \$600; 3914-04A Tape Loop Adapters for repetitive playback up to 100 feet of 1/2" and 1" tape respectively, \$750.

### Accessories

**High performance instrumentation tape:** (for 3917B and 3924B only) 37T-17, 1/2" 1 mil 3600' on phenolic

hub reels; 1 to 9, \$50.60 ea., 10 to 49, \$49.35 ea., 50 or over, \$48.15 ea.; 37T-16, 1" 1 mil 3600' on phenolic hub reels, \$91.30 ea.

**Empty reels:** 37T-14, 10 $\frac{1}{2}$ " diam., phenolic hub for 1/2" tape, \$6 ea.; 37T-15, 10 $\frac{1}{2}$ " diam., phenolic hub for 1" tape, \$7.50 ea.

**Optional accessories:** 37T-7 splicing tape, 1/2" Mylar, 100 + feet, \$1.55; 48A-13 bulk eraser, Cinema Type 9205A, \$102; 48A-14, head demagnetizer, Robins Type HD-6, \$12.50; 48A-15, 1/2" tape splicer, Robins Type TS-500, \$77; 01060-69010 Cabinet Dust Cover, gabardine, \$45.

**Prices:** Note 1: 3907B (less 7-channels of record/reproduce amplifier inserts and associated equalization plug-ins), \$6185; 3917B (less 7-channels of record/reproduce amplifier inserts and associated equalization plug-ins), \$6935; 3914B (less amplifier inserts and plug-ins), \$8415; 3924B (less amplifier inserts and plug-ins), \$9915.

**Option 01:** same as above, less cabinet but including all hardware for 19" rack mounting: 3907B Option 01, \$5680; 3914B Option 01, \$7910; 3917B Option 01, \$6430; 3924B Option 01, \$9410.

**Option 02:** same as above but mounted in portable cabinets: 3907B Option 02, \$6185, 3914A Option 02, \$8415; 3917A Option 02, \$6735; 3924A Option 02, \$9915.

**Electronics narrowband bandwidth recorders:** Model 3900-12B (Direct record/reproduce insert less plug-in), \$173 ea; plug-ins: 2000-1200-2 for 1 $\frac{7}{8}$  ips, \$45; 3900-21A for 3 $\frac{3}{4}$  ips, \$45; 3900-23B for 7 $\frac{1}{2}$  ips, \$45; 3900-23A for 15 ips, \$45; 3900-24A for 30 ips, \$45; 3900-25A for 60 ips, \$40; 3900-13B (FM record/reproduce insert less plug-in), \$198 ea; plug-ins: 2000-1300-C2 for 1 $\frac{7}{8}$  ips, \$61; 2000-1300-C3 for 3 $\frac{3}{4}$  ips, \$45; 2000-1300-C4 for 7 $\frac{1}{2}$  ips, \$45; 2000-1300-C5 for 15 ips, \$40; 2000-1300-C6 for 30 ips, \$41; 2000-1300-C7 for 60 ips, \$45; 3900-14A (Pulse record/reproduce insert, no plug-ins required), \$125 ea.

**Electronics medium bandwidth recorders:** 3900-12B (Direct record/reproduce insert less plug-in), \$173 ea; plug-ins: 3900-22A for 1 $\frac{7}{8}$  ips, \$45; 3900-23A for 3 $\frac{3}{4}$  ips, \$45; 3900-24A for 7 $\frac{1}{2}$  ips, \$45; 3900-25A for 15 ips, \$40; 3900-26A for 30 ips, \$40; 3900-26B for 60 ips, \$40; 3900-13B (FM record/reproduce insert less plug-in), \$198 ea; plug-ins: 2000-1300-C3 for 1 $\frac{7}{8}$  ips, \$45; 2000-1300-C4 for 3 $\frac{3}{4}$  ips, \$45; 2000-1300-C5 for 7 $\frac{1}{2}$  ips, \$40; 2000-1300-C6 for 15 ips, \$41; 2000-1300-C7 for 30 ips, \$45; 2000-1300-C11 for 60 ips, \$63. 3900-14A (Pulse record/reproduce insert, no plug-ins required), \$125.

**Note 1:** add price of inserts and plug-ins times the number of channels and speeds you require to the basic assembly price above for complete system cost.

## MAGNETIC TAPE RECORDERS

Versatile, reliable 300 kHz and 1.5 MHz systems  
3955, 3950 Series



# RECORDERS

Hewlett-Packard 3950 and 3955 Series Magnetic Tape Recorders are versatile and reliable means for recording and/or reproducing large amounts of data. With up to seven or fourteen channels, six electrically switchable operating speeds, and capacity for tape reels of up to 15 inches in diameter, the systems provide a wide choice of operating modes.

Each system includes a high-performance tape transport, and record and reproduce amplifiers for the number of channels desired (up to seven or fourteen depending on the tape width used and the number of amplifier mainframes supplied). Simple and straightforward design of both the tape transport and the amplifiers assures reliable operation with a minimum of routine adjustment and maintenance. Accessory equipment can be used with these systems to further increase their versatility and provide for individual data recording needs.

Maximum bandwidth for the 3955 Series is 300 kHz Direct and 20 kHz FM at 60 ips. Plug-in Direct and FM amplifiers are interchangeable. In addition, two basic transports are available for this series. The smaller transport, which can handle tape reels up to 10½ inches in diameter, is for applications requiring average recording times or minimum panel space. The larger transport accepts reels up to 15 inches in diameter to provide over twice the recording time of the small unit, over 19 hours at the slowest speed. It also accommodates a wider choice of accessories.

A direct bandwidth of 1.5 MHz at 120 ips is provided by the 3950 Series. Both record and reproduce amplifiers are plug-in and are interchangeable with intermediate bandwidth FM electronics with 20 kHz response at 60 ips. Wide-band FM, providing dc to 400 kHz bandwidth at 120 ips, is also available. Because of the higher tape speeds used in wide-band recording, only a large reel (up to 15 inches diameter) transport is offered as standard with 3950 Series Systems. It provides over 17 minutes recording time at 120 ips.

### Simple reliable tape transports

The outstanding electrical and mechanical performance of the tape transports is inherent in their simple, straightforward design. The rugged cast aluminum transport frame is precision finished on automated machine tools to insure proper alignment of all parts of the tape drive system. Close

### System capabilities

Model	Bandwidth (max)		Tape width (in.)	Tracks	Reel size (max. in.)
	Direct Record Mode	FM Record Mode			
3950A	1.5 MHz	(a)	1	14	15
3950B	1.5 MHz	(a)	½	7	15
3955A	300 kHz	DC-20 kHz	1	14	15
3955B	300 kHz	DC-20 kHz	½	7	15
3955C	300 kHz	DC-20 kHz	1	14	10½
3955D	300 kHz	DC-20 kHz	½	7	10½

(a) Accepts dc to 20 kHz FM amplifiers interchangeably with 1.5 MHz direct mode amplifiers. Also available with dc to 400 kHz FM amplifiers added to system equipped with 1.5 MHz direct mode amplifiers.

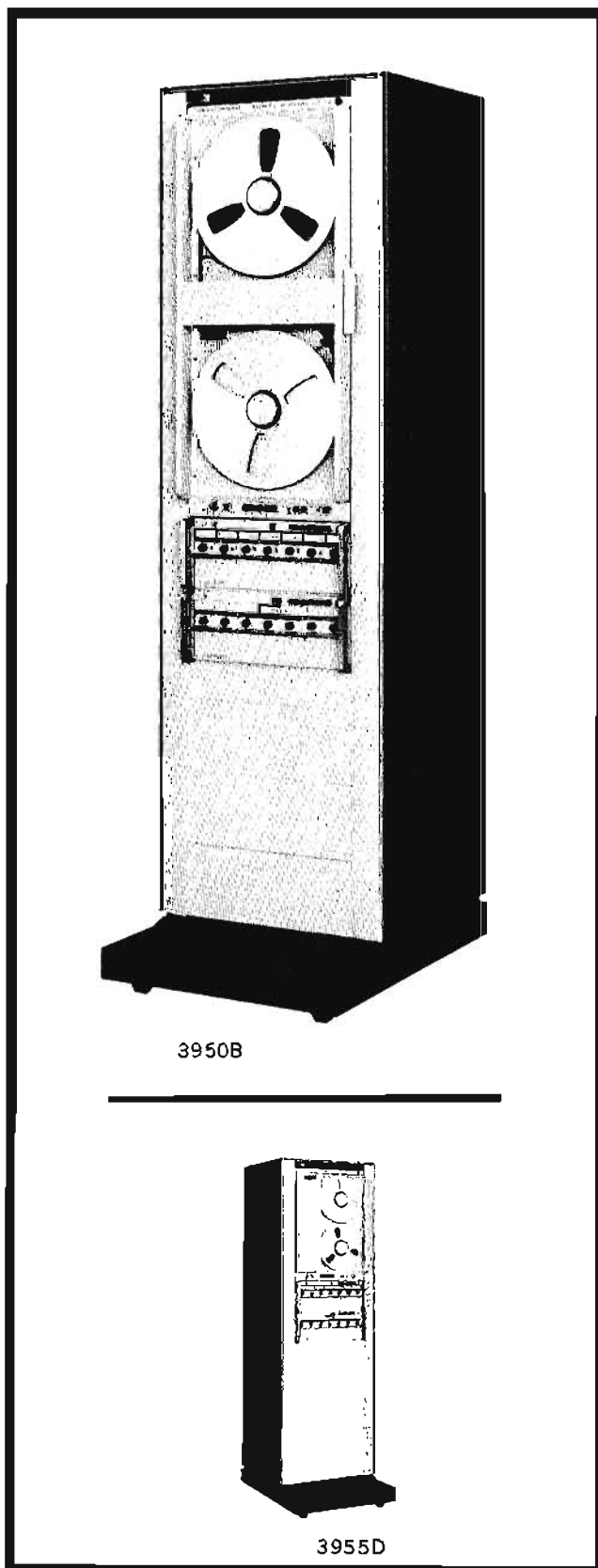



## MAGNETIC TAPE RECORDERS CONTINUED

Versatile, reliable 300 kHz and 1.5 MHz systems  
3955, 3950 Series

tolerances in the computer-controlled machining process assures parts interchangeability without need for complex alignment adjustments in the transport mechanism.

Exceptionally good motional stability is achieved by the damped open-loop tape drive system (Figure 1) which requires little maintenance. Unique hermetically sealed fluid damping and sophisticated mechanical considerations in the drive system contribute to the flutter and wow performance which are comparable to that normally associated with more complex drive systems. The design of the tape path in the smaller transport, which has constant torque holdback on the supply reel, assures accurate tape speed as well as motional stability. As the supply reel empties, friction in the

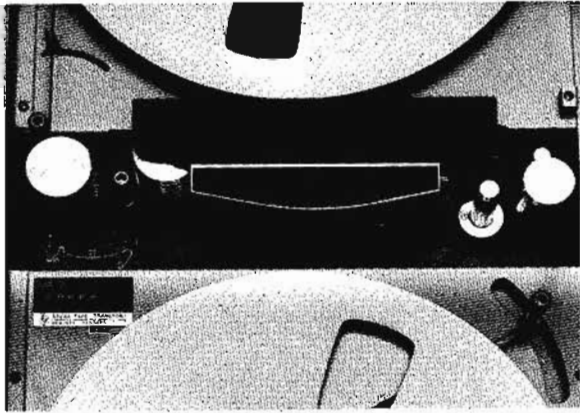

Figure 1. Tape is threaded quickly into simple open-loop tape drive.

tape path decreases, compensating for the increased holdback force from the supply reel. The larger transport, which has constant tension holdback has even better speed accuracy.

All operating controls for the system are located on the transport chassis. Pushbuttons are utilized throughout to obtain the desired mode of operation. Rear connectors are provided for remote control operation, accessories, and interconnecting cabling to other parts of the tape recording system.

A transparent door completely covers the reels and tape drive path to protect these parts from dust and damage. The control buttons are left uncovered for ready access when changing operating modes. The transports are slide mounted. When withdrawn, they can be tilted in either direction for complete accessibility of all parts for maintenance purposes.

The rear of the tape transports are uncluttered, with all parts easily accessible. Both transport mechanisms are virtually adjustment free. The very simplicity of these transports insures both high reliability and minimum downtime when maintenance is required. Removable cover panels protect the user from all rotating parts and high voltages. The 7- and 14-track record/reproduce head assemblies conform to generally accepted industry standards for magnetic heads and tape format as specified in IRIG (Inter-Range Instrumentation Group) Document 106-66 (Section 5.6). In addition, for best alignment, the head stacks are mounted on a single precision baseplate. Because they are prealigned, head assem-

blies are easily field replaceable. Precision machining of all mating parts alleviates the need for adjustments when the head assemblies are mounted on the transports except for a minor azimuth adjustment of the reproduce heads on the 3950 Series.

Tape transports are equipped to operate with either 1/2- or 1-inch tape. However, a transport originally equipped with either tape width can be readily converted to the other at any later time. Only the head assembly, three tape guides, the pinch roller, and two reel holddown spindles need to be changed. Kits are available for conversion in the field. Thus, a system originally equipped with a 7-track head assembly and 7 channels of electronics can be expanded to 14 channels merely by installing the appropriate conversion kit and adding an additional 7 channels of electronics.

Each transport includes a tape footage counter with an accuracy of  $\pm 0.05\%$  at all speeds including fast rewind. In addition, the larger transports include a digital elapsed time meter which operates whenever the tape travels across the heads. The meter has a maximum indication of 9999.9 hours.

### Amplifiers

The record and reproduce amplifiers are completely solid-state. They are small, convenient, modular units designed for mounting in simple mainframes as shown in Figures 2 and 3. Each 7-channel mainframe is 7 inches high and provides power supply voltages, signal connections, and metering for the amplifiers. All signal input and output connectors are BNC female.

The reproduce amplifier used in these systems is especially well suited to magnetic head characteristics. The Hewlett-Packard preamplifier, which evolved from other areas of magnetic development in Hewlett-Packard laboratories, gives outstanding signal-to-noise performance.

Metal cover doors for amplifier mainframes (shown open in Figures 2 and 3) open downward to provide access to adjustments and to permit easy removal of the record and reproduce amplifiers. In the open position, the cover doors may be depressed to unlock the modular amplifiers from the mainframe for easy removal.

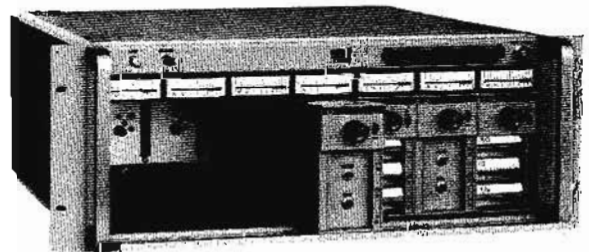

Figure 2. Record Mainframe holds up to seven Record Amplifiers.



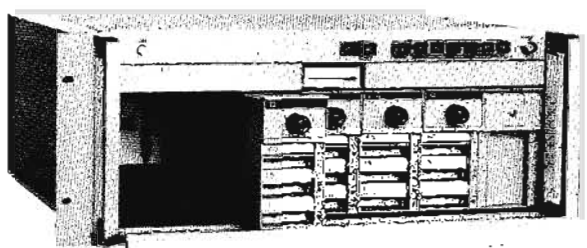

Figure 3. Reproduce Mainframe holds up to seven Reproduce Amplifiers. Dummy amplifier is shown on right.

### Signal monitoring

**Direct Recording.** The record mainframe includes a bias oscillator and seven average responding meters calibrated in dB for monitoring the channel recording levels. In the record mode the high frequency recording bias current on each head within the head stack can be sensed on the monitoring meters by depressing the switch on the face of the associated record amplifier. A record level control to accommodate various input signal levels is on the front of each amplifier. (Figure 4). Screwdriver adjustments are accessible from the front panel of each amplifier for setting bias level and for calibrating the meter.

**FM Recording.** The record mainframe meters can also be used to monitor ac signal levels for FM recording, reading on the dB scales. Or, using the zero-centered scale, the meter indicates relative carrier frequency deviation in response to a dc input signal. A switch on the front panel of each FM record amplifier selects either the ac or dc meter function.

The reproduce mainframe provides for monitoring the

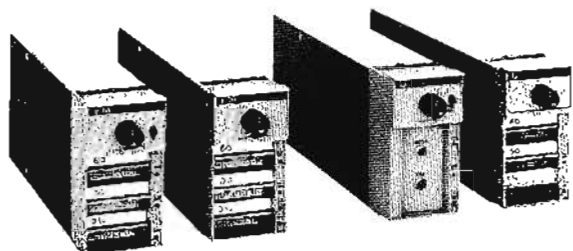

Figure 4. Record and Reproduce Amplifiers. FM Record, FM Reproduce, and Direct Reproduce Amplifiers are shown with three tape-speed-related networks installed in each. Direct Record Amplifier tape speed compensation is correct for all speeds.

output without disturbing input monitors. It has a single average-responding meter and 7 pushbuttons, one for each track. (In most cases tape recording outputs are scanned one channel at a time.) The meter has both a dB scale and a zero-center scale identical to those in the meters on the record mainframe. Pushbuttons above the meter in the reproduce mainframe select the ac or dc meter function. An output gain control is provided on the front of each Direct and FM reproduce amplifier. These controls are accessible with the mainframe door closed.

The FM record, direct reproduce, and FM reproduce amplifiers all require different networks for each tape speed. Each circuit is mounted on a convenient plug-in card as shown in Figure 5.

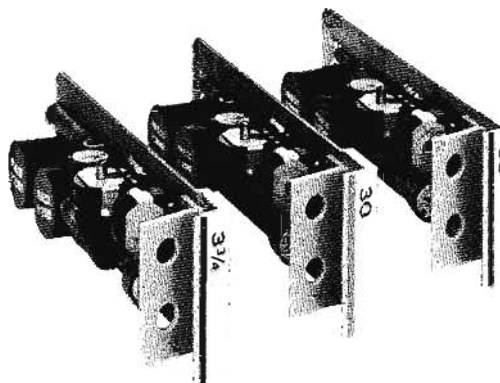

Figure 5. Tape-speed networks. They can be inserted into or removed from an amplifier from the front.

Attached to each card is a push-bar with the tape speed indicated numerically and, in addition, a colored stripe to match the color of the speed pushbutton on the tape transport. The amplifiers simultaneously accommodate networks for three different tape speeds. The desired one is selected by pushing on the push-bar. A mechanical "teeter-totter" automatically removes the previously operating unit from the circuit. The plug-in design of the networks allows rapid substitution of units for any speed, or of an entirely new set. These are replaceable from the front panel of the amplifier without removing the amplifier from the mainframe.

### Test signals & channel adjustments

The record mainframe has 7 pushbuttons for introducing test signals to the desired track. To apply a test signal to a track, simply connect it to the record mainframe front panel test jack and depress the appropriate pushbutton. This disconnects the rear input data signal and inserts the test signal into the desired record amplifier.

In the record mode the recorded test signal is reproduced with a delay equal to 3.5 inches of tape length and is available at the output of the appropriate reproduce amplifier. It can be monitored by depressing the channel pushbutton on the reproduce mainframe to connect the reproduce monitor meter and front panel test jack to the desired reproduce amplifier. Using this technique, it is easy to quickly check all channels for proper operation from the front panel.

### Accessories

A variety of accessory equipment can be used with these systems to further increase their versatility and provide for individual data recording needs. The Model 3680A AC Power Supply provides accurate tape speeds even when operating from variable-frequency power sources such as motor generators. The 3680A supplies crystal controlled 60-Hz power to the capstan motor to eliminate the minor variations in speed which might result from variations in the normal 60-Hz power source. To provide additional accuracy for both recording and reproducing, the Model 3681A Tape-speed Servo Unit may be used with the 3680A. The 3681A provides a choice of standard IRIG speed-control signals for recording on the tape at the time that data is recorded. When the tape is replayed, the reference speed-control signal from the tape is supplied to the 3681A. It controls the tape speed so that data signals are reproduced at exactly the frequencies at which they were recorded.



# RECORDERS



## MAGNETIC TAPE RECORDERS CONTINUED Versatile, reliable 300 kHz and 1.5 MHz systems 3955, 3950 Series

The Model 11553A Tape Pack Sensor, available for 15-inch reel transports only, senses the remaining tape pack on both supply and take up reels. This accessory permits a system to be stopped before the tape is unthreaded from the reels, or to be recycled. Alternately, a second recording system may be turned on before the first runs out of tape. Thus, continuous and/or remote monitoring can be done automatically.

The 3604A Voice Channel includes a microphone and loudspeaker. It is designed for recording and reproducing voice signals in the low-frequency portion (below 10 kHz) of the spectrum on any data track of the 3950 or 3955 Series equipped with Direct Record amplifiers. The 3604A is equipped with rear-panel input and output connectors and includes filters to permit recording carrier frequency type data signals in the upper frequency portion (above 20 kHz) of the same channel. An optional version, 3604-A Option 01, is available for edge track recording with the 3955 Series, which include an edge track in the heads. The full bandwidth of all data tracks is then available for data signals. The 3950 Series bandwidth is so great that voice recording uses only a negligible portion, so edge tracks are not used in this series.

The Model 11539A Reproduce Track Selector permits economies in the system by using fewer reproduce than record amplifiers. From 1 to 7 channels of reproduce electronics may be used to reproduce data from up to 14 record channels. The track selector includes seven switches with 14 positions each for routing the signal from any one of 14 reproduce head tracks to a given reproduce amplifier. Other accessory items, such as monitor oscilloscopes, bulk tape degaussers, storage drawers, and fan assemblies, are also available.

### Specifications 3955 Series

Intermediate Band Direct Record/Reproduce System (Combined record and reproduce performance with Model 3534A Direct Record Amplifier and 3537A Direct Reproduce Amplifier and tape-speed networks.)

#### Frequency response:

Tape speed (ips)	3-dB Bandwidth	Signal-to-noise ratio (rms/rms) filtered*	ratio (rms/rms) unfiltered
60	300 Hz-300 kHz	>40 dB	>35 dB
30	150 Hz-150 kHz	>40 dB	>35 dB
15	100 Hz- 75 kHz	>40 dB	>35 dB
7½	100 Hz- 38 kHz	>40 dB	>35 dB
3¾	100 Hz- 19 kHz	>40 dB	>35 dB
1½	100 Hz- 9.5 kHz	>40 dB	>35 dB

\*With bandpass filter at output with 18 dB/octave rolloff, 3 dB down at band edge, using good quality instrumentation tape; system noise is limited by tape signal-to-noise ratio.

**Equalization and phase response:** each reproduce amplifier simultaneously holds equalizers for any three speeds; equalizers include all-pass network for phase compensation, adjustable for best square wave response.

**Input level:** 1 V rms (2.8 V p-p) nominal for 1% third-harmonic distortion recorded on tape. Adjustable from 0.15 V rms (0.4 V p-p) to 10 V rms (28 V p-p).

**Input Impedance:** 20,000Ω minimum shunted by 150 pF, unbalanced to ground.

**Output level:** up to 1 V rms (2.8 V p-p) into 1 kΩ or greater, 0.5 V rms into 50Ω; adjustable to zero.

**Output Impedance:** 50Ω ±20%, single ended.

**Harmonic distortion:** when recording at the normal level (1% third harmonic distortion on tape—1 kHz reference) or less, all other harmonic distortion is 1% or less.

**Connectors (input and output):** BNC female.

### Intermediate Band FM Record/Reproduce System

(Combined record and reproduce performance with Model 3535A FM Record Amplifier and 3538A FM Reproduce Amplifier and speed-related networks. These are interchangeable with the above intermediate band direct record/reproduce amplifiers.)

#### Bandwidth:

Tape speed (ips)	Bandwidth*	FM center carrier frequency	Signal-to-noise ratio (rms/rms) at center frequency**
60	0-20 kHz	108 kHz	>48 dB
30	0-10 kHz	54 kHz	>48 dB
15	0-5 kHz	27 kHz	>48 dB
7½	0-2.5 kHz	13.5 kHz	>47 dB
3¾	0-1.25 kHz	6.75 kHz	>45 dB
1½	0-625 Hz	3.375 kHz	>41 dB

\*Frequency response +0.5, -1 dB with 600Ω load and output filter adjusted for flat amplitude response. May also be set for best squarewave response.

\*\*Use of HP 3538A Option 01 FM Reproduce Amplifier Flutter Compensation further improves S/N. Front-panel switch selects use for flutter compensation or as a standard amplifier.

**Input level:** ±0.7 V peak (0.5 V rms) to ±15 V peak (10 V rms), adjustable.

**FM deviation:** ±40% from center carrier frequency for full scale input signal (IRIG standard); greater than ±60% deviation permissible without significant signal degradation.

**Input Impedance:** at least 20,000Ω shunted by 150 pF, unbalanced to ground.

**Output level:** 2.8 V p-p (1 V rms) into 600Ω, 5.6 V p-p (2 V rms) open circuit; adjustable down to 0.3 V p-p. Adjustment provided for setting output to 0 V dc when input is center frequency.

**Output Impedance:** 600Ω, unbalanced to ground.

**Linearity:** less than ±1% of p-p output from a zero based straight line.

**Total harmonic distortion:** 1.5% maximum.

**Drift:** with temperature: ≤ ±0.4% of p-p output for any 10°F change between 32 and 131°F; with line voltage: ≤ ±0.25% for 10 V change; with time: ≤ ±0.5% of p-p output in 8 hr. after 20-min. warmup.

**Signal connectors (input and output):** BNC female.

### 3950 Series Wideband Direct Record/Reproduce System

(Combined record and reproduce performance with Model 3540A Direct Record Amplifier and 3543A Direct Reproduce Amplifier and equalizers.)

#### Frequency response:

Speed (ips)	Bandwidth*	S/N ratio (rms/rms)**	Maximum rise time***
120	0.4 kHz-1.5 MHz	> 30 dB	< 0.4 $\mu$ s
60	0.4 kHz-750 kHz	> 29 dB	< 0.8 $\mu$ s
30	0.4 kHz-375 kHz	> 29 dB	< 1.6 $\mu$ s
15	0.4 kHz-187.5 kHz	> 28 dB	< 3.2 $\mu$ s
7½	0.4 kHz-94 kHz	> 27 dB	< 6.4 $\mu$ s
3¾	0.4 kHz-47 kHz	> 26 dB	< 12.8 $\mu$ s

#### Typical noise levels for various noise bandwidths:

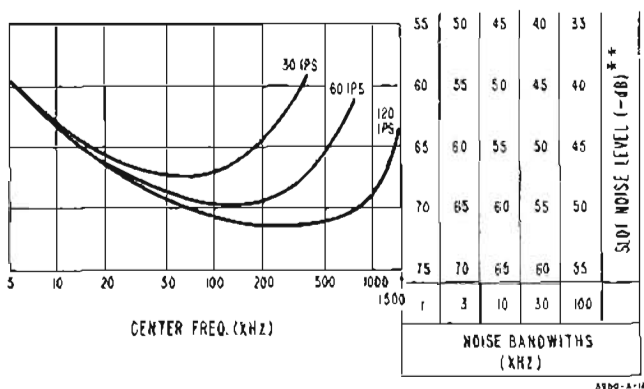

\*±3 dB, 10 kHz to upper band edge; ±4 dB, 0.4 kHz to upper band edge.

\*\*Record level at 1% 3rd harmonic distortion on tape for a reference signal frequency of 0.1 times upper band edge; S/N measured using -18 dB/octave filter 2 dB down at band edge.

\*\*\*Fundamental of square wave at 0.1 times upper band edge.

**Equalization and phase response:** each reproduce amplifier simultaneously holds equalizers for any three speeds; equalizers include all-pass network for phase compensation, adjustable for best square wave response.

**Input level:** 0.25 to 30 V rms.

**Input impedance:** 1000 $\Omega$ , 70 pF, unbalanced to ground.

**Output level:** up to 1 V rms into 75 $\Omega$ .

**Output impedance:** 75 $\Omega$ , unbalanced to ground.

**Harmonic distortion:** when recording at the normal level (1% third harmonic distortion on tape) or less at any frequency, electronically caused distortion is less than 0.5%.

#### Front-panel operating controls:

**Record:** Record Level Meter Adjust, Record Level Control; Bias Level Control, Bias Indicator Switch, and Bias and Input Test Points.

**Reproduce:** Output Gain Control, Equalizer Amplitude Adjust, and Pre-amp Output Test Points.

**Signal connectors (input and output):** BNC female.

### Intermediate Band FM Record/Reproduce System

(Combined record and reproduce performance with Model 3535A Option 01 FM Record Amplifier and 3538A FM Reproduce Amplifier and speed-related networks. These are interchangeable with the above wideband direct record/reproduce amplifiers.)

#### Bandwidth:

Tape speed (ips)	Bandwidth*	FM center carrier frequency	Signal-to-noise ratio (rms/rms)**
120	(a)		
60	0-20 kHz	108 kHz	> 48 dB
30	0-10 kHz	54 kHz	> 48 dB
15	0-5 kHz	27 kHz	> 48 dB
7½	0-2.5 kHz	13.5 kHz	> 47 dB
3¾	0-1.25 kHz	6.75 kHz	> 45 dB

\*Frequency response +0.5, -1 dB with 600 $\Omega$  load and output filter adjusted for flat amplitude response. May also be set for best squarewave response.

\*\*Use of HP 3538A Option 01 FM Reproduce Amplifier Flutter Compensation further improves S/N. Front-panel switch selects use for flutter compensation or as a standard amplifier.

(a) Increased range under development. In 3950 Series System the tape can be operated at ½ the speeds listed with only slight degradation in signal-to-noise ratio.

For additional specifications, see 3955 Series.

### Wideband FM Record/Reproduce System

A bandwidth of dc to 400 kHz at 120 ips with a signal-to-noise ratio (rms/rms) of better than 30 dB is available with optional electronics. These are added to systems equipped with wideband direct record/reproduce amplifiers.

### 3955 and 3950 Series Tape Transports

Speeds	Bandwidth	Flutter (p-p)*
3950 Series		
120 ips	0-200 Hz 0-1.5 kHz 0-10 kHz	0.2% 0.3% 0.6%
60	0-200 Hz 0-1.5 kHz 0-10 kHz	0.2% 0.3% 0.6%
30	0-200 Hz 0-1.5 kHz 0-5 kHz	0.2% 0.5% 0.8%
15	0-200 Hz 0-1.5 kHz 0-2.5 kHz	0.25% 0.45% 0.6%
7½	0-200 Hz 0-1.25 kHz	0.4% 0.65%
3¾	0-200 Hz 0-625 Hz	0.5% 0.8%
	1¾	0.8% 1.2% 1.5%
3955 Series		

\*If expressed as rms flutter, the values would be 1/5 to 1/4 of those listed. IRIG 106-65 specifies that flutter be within stated peak-to-peak limits 95% of the time. On this basis, values of flutter are substantially lower.

**Time jitter:** the random jitter in the reproduced signal between any two events is typically within the following peak-to-peak 3 sigma limits (i.e., 99.7% of the time):

Tape speed ips	Time interval milliseconds	Jitter p-p microseconds
3950		
120	0.1	0.3
120	1	1.5
60	0.1	0.4
60	1	2.0
30	0.1	0.4
30	1	3.0
15	0.1	0.6
15	1	5.0
3955		

# RECORDERS



## MAGNETIC TAPE RECORDERS CONTINUED

Versatile, reliable 300 kHz and 1.5 MHz systems  
3955, 3950 Series

**Total Interchannel time displacement error (static and dynamic):**  $\pm 1 \mu\text{sec}$  at 60 ips,  $\pm 0.5 \mu\text{sec}$  at 120 ips between two adjacent tracks on same head stack.

**Drive system:** open loop, damped.

**Drive speed accuracy:**

**With standard commercial power (60 Hz  $\pm 0.03\%$ ):**  $\pm 0.25\%$  of nominal capstan speed with 1.0-mil tape. Speed proportional to line frequency.

**With 47 to 63 Hz line frequency:**  $\pm 0.25\%$  of nominal capstan speed with 1.0-mil tape when capstan is powered by optional HP 3680A AC Power Supply;  $\pm 0.02\%$  of nominal capstan speed using optional HP 3681A Tapespeed Servo and 3680A AC Power Supply; speed control signals meet IRIG 106-66, Section 6.3.6.2. (50 Hz and/or 220 V operation also available.)

**Operating controls:** Stop, Play, Reverse, Forward, Record, Speed (6), and Power.

**Start time:** within speed limits in approximately 6 sec.; flutter within specifications in approximately 10 sec. at 60 ips.

**Stop time:** approximately 1 second from 60 ips; braking by feedback-type mechanical brakes which provide power-fail-safe operation in all modes.

**Rewind time:** approximately 4 minutes for 9,200 ft.,  $4\frac{1}{2}$  minutes for 10,800 ft.

**Remote control:** connectors on rear permit remote control of all transport operations except speed selection.

**Tape footage counter:** 5 digits,  $\pm 0.05\%$  accuracy.

**Tape Interruption sensing:** tape breakage or end-of-tape runout is sensed by the take-up-reel tensioning arm to stop the transport. Optional 11553A Tape Pack Sensor stops or reverses transport prior to end of tape.

Tape length:	Tape length (ft)		
	1-mil backing	0.4-mil Coating <sup>2</sup>	1.6-mil backing
Reel OD (in.)	0.2-mil Coating <sup>1</sup>	0.4-mil Coating <sup>2</sup>	0.4-mil Coating
10½	4,600	3,600	2,500
14	9,200 <sup>3</sup>	7,200 <sup>3</sup>	5,000
15	10,800	9,200	6,800

<sup>1</sup>Typical for 3950 Series.

<sup>2</sup>Typical for 3955 Series.

<sup>3</sup>14 in. tape and empty reel furnished with systems accommodating large reels.

**Elapsed time meter 3950, 3955A/B only:** digital clock type, five digits to 9999.9 hours; operates when tape moves across heads.

### Heads

**Magnetic head assembly:** the head assemblies meet IRIG document 106-66, Part 6, including mechanical geometry, numbering, azimuth, and polarity specifications.

**Data tracks:** 7 tracks on  $\frac{1}{2}$  in. and 14 tracks on 1 in. wide magnetic tape.

**Edge track (3955 Series only):** one edge track provided in addition to data tracks on each head assembly; BNC input and output connectors provided for direct connection of head windings to optional HP 3604A Voice Channel Amplifier. (See 3604A under accessories for use with 3950 Series.)

### General

**Power requirements:** 115 V  $\pm 10\%$ , 60 Hz nominal (refer to transport drive speed accuracy), approximately 600 W (14-channel system) 450 W (7-channel system); add 360 W for 3680A AC Power Supply; 230 V and/or 50 Hz operation optional.

**System size and weight:** cabinet dimensions including extended base with casters,  $82\frac{3}{8}$ " high,  $23\frac{7}{8}$ " wide,  $35\text{-}11\frac{1}{16}$ " deep (2099 x 607 x 907 mm), providing  $73\frac{1}{2}$ " (1867 mm) of vertical panel space; other cabinet sizes and base configurations available. Weight depends upon the number of channels supplied. Typical 7-channel system in-cabinet weight approximately 575 lbs (257 kg); shipping weight approximately 800 lbs (360 kg). Typical 14-channel in-cabinet net weight approximately 675 lbs (304 kg); shipping weight approximately 900 lbs (405 kg).

### Ordering information

Record and reproduce amplifiers and amplifier equalizers must be ordered individually to complete the above systems. Dummy amplifiers required to complete connections in unused channels.

All systems are assembled and fully tested before shipment. Individual items ordered separately for use with existing systems or for field system assembly receive a simulated systems test to assure complete compatibility and full rated performance.

**Accessories furnished:**

**3950, 3955A/B:** one 14-in. precision tape reel with 1.0-mil instrumentation tape, 1 or  $\frac{1}{2}$  in. wide as required for transport; one 14-in. precision tape reel, empty.

**3955C/D:** one 10½ in. precision tape reel with 1.0-mil instrumentation tape, 1 or  $\frac{1}{2}$  in. wide as required for transport; one 10½ in. precision tape reel, empty.

**All systems:** all necessary mating connectors except BNC. Power cable, ac line to cabinet, 10 ft. (3050 mm). Two operating and maintenance manuals. Maintenance kit including extenders, spare fuses, and adjusting tools. Filler panels for non-occupied cabinet mounting space (furnished only if cabinet is included in order).

**Prices<sup>1</sup>:**

HP Model	Reel size (max. in.)	Tracks	Price	
			Direct systems <sup>2</sup>	FM systems <sup>2,3</sup>
			1.5 MHz (max.)	DC to 20 kHz (max.)
3950A	15	14	\$19,700	\$21,030
3950B	15	7	\$13,350	\$14,015
			300 kHz (max.)	DC to 20 kHz (max.)
3955A	15	14	\$14,500	\$17,930
3955B	15	7	\$10,050	\$11,765
3955C	10½	14	\$14,000	\$17,430
3955D	10½	7	\$ 9,550	\$11,265

1. Standard features included in all systems at above prices.

1. Meters on all record channels.

2. Meter, switched, in each reproduce mainframe.

3. Tape footage counter.

4. Bias oscillator in record mainframes.

5. Reel of high quality instrumentation tape and empty reel.

2. With a full set of reproduce as well as record amplifiers. Direct record amplifiers operate at all six speeds. Above prices include speed-related networks for any three speeds for all Direct Reproduce, FM Record, and FM Reproduce amplifiers.

3. DC to 400 kHz wideband FM optionally available for 3950 Series.

# Electronic Instrumentation and Components

<b>Solid-State Devices</b> . . . . .	<b>162</b>	<b>Noise Figure</b> . . . . .	<b>384</b>
Step Recovery Diodes, Hot Carrier Diodes; High Conductance Diodes; PIN Diodes; Microwave Switches; Variable Attenuators; Photoconductor Devices; Optoelectronic Devices		Noise Figure Meter, Noise Sources	
<b>Working Standards</b> . . . . .	<b>170</b>	<b>Analyzers</b> . . . . .	<b>386</b>
Standard Resistors; DC Standards; AC and DC Differential Voltmeters; DC Null Meters; AC/DC Meter Calibrator; Thermal Converters		Wave Analyzers, Distortion Analyzers, Spectrum Analyzers, Frequency Comb Generator, Slot Filters	
<b>Voltage, Current, Resistance</b> . . . . .	<b>180</b>	<b>Amplifiers</b> . . . . .	<b>400</b>
DC Null Meters; AC Voltmeters; Sampling Volt- meter; Multifunction Meters; DC Autovoltmeter; DC Clip-on Milliammeter; Magnetometer Probe; Differential Voltmeters; Differential-Ratio Voltmeter; Digital Voltmeters; Potentiometric DVM; AC-Ohms Converter		Data Amplifier; Differential DC Amplifier; Operational Amplifiers; Power Amplifier; Fast Pulse Amplifiers; Wide Band Amplifiers; Microwave Amplifiers	
<b>Impedance</b> . . . . .	<b>236</b>	<b>Oscilloscopes</b> . . . . .	<b>415</b>
Vector Voltmeters; Vector Impedance Meters; Network Analyzer; Universal Bridge; Rx Meter; Q Meters; SWR Meters; Ratio Meter; Slotted Sections		Dual-Trace, Dual-Beam, Plug-In Oscilloscopes; Variable Persistence Oscilloscope; Sampling Oscilloscopes; Swept Frequency Indicator; Time Domain Reflectometer; Programmable Oscilloscope; Probes; Test Mobiles; Cameras; Accessories	
<b>Coaxial, Waveguide</b> . . . . .	<b>262</b>	<b>DC Power Supplies</b> . . . . .	<b>463</b>
Filters; Detectors; Directional Couplers; Tuners; Phase Shifters; Bolometer Mounts; Directional Detectors; Terminations; Shorts; Loads; Reflections		General-Purpose, High-Stability, Medium-Power, High-Voltage Bench Supplies; Dual-Power Rack Supplies; Low-Voltage, Medium-Voltage Rack Supplies; SCR Supplies; Modular Plug-in- Regulated Supplies; Klystron Supplies	
<b>Communications Test Equipment</b> . . . . .	<b>280</b>	<b>Frequency</b> . . . . .	<b>494</b>
Ultrasonic Leak Detectors; Cable Fault Locators; Telephone Test Set; Telephone Test Oscillator; Distortion Analyzers; TV Waveform Oscilloscopes; CATV Cable Tester		Electronic Counters; Frequency Converters; Prescalers; DVM Plug-in; Transfer Oscillator; Auto Frequency Divider; Pre-Set Counter; Reversible Counter; Time Interval Counter; Frequency Meters; Wavemeters	
<b>Signal Sources</b> . . . . .	<b>302</b>	<b>Frequency, Time Standards</b> . . . . .	<b>531</b>
Function Generators; Square-Wave Generators; Pulse Generators; Digital Delay Generators; Oscillators, Audio-Signal Generators; Test Oscillators; Signal Generators; Microwave Synchronizer; Frequency Doublers; Spectrum Generator; AM/FM Signal Generator; Telemetry Test Set; Navigational Test Sets; Sweep Generators		Frequency Synthesizers; Cesium Beam Standards; Standby Power Supplies; Quartz Oscillators; VLF Comparator	
<b>Mixers, Modulators, Attenuators</b> . . . . .	<b>368</b>	<b>Nuclear</b> . . . . .	<b>552</b>
Double-Balanced Mixer; Modulator Drivers; PIN Modulators; Attenuators		Spectrum Scanner; Scaler-Timers; Scintillation Detectors; Amplifiers; High Voltage Power Supply; Lead Shield	
<b>Power</b> . . . . .	<b>375</b>	<b>Temperature</b> . . . . .	<b>559</b>
Power Meters, Mounts; Peak Power Meter; Calorimetric Power Meter		Quartz Thermometer, Probes	
		<b>Physical Measurements</b> . . . . .	<b>562</b>
		Signal Conditioners	
		<b>Leak, Friction Detectors</b> . . . . .	<b>563</b>
		<b>Cabinets, Hardware</b> . . . . .	<b>568</b>
		Modular Cabinets; Hardware	



Successful production of quality components for tomorrow's electronic instruments and systems is greatly dependent on a delicate balancing of science, technology and manufacturing. HP Associates has achieved this important balance, and as a result, has become a recognized leader in solid-state technology and manufacture of highly specialized devices. HP Associates is built around a competent and imaginative staff; they have at their disposal up-to-date manufacturing and laboratory facilities. Their prime objective is the invention, engineering and production of devices unexcelled in contribution to the state of the art, in reliability and in total performance. The organization has been optimized to achieve objectives with minimum time delay and expenditure of manpower. HP Associates has already obtained the status of world leadership in the metal-on-semiconductor technology and is following in other technologies, such as optoelectronics, photoconductor, and microwave components.

The standard HPA devices described on the following pages are available in the packages shown below. Other package configurations are, of course, available on request.

### Step recovery diodes

HPA introduced the Step Recovery Diode and continues to set the pace in this technology. The recently announced 0300 S-band diode is the first of a new generation of HPA Step Recovery Diodes. An X-band diode, the 0320, will be available shortly with a C-band diode, the 0310, soon to follow.

### Hot carrier diodes

Another HPA development, the hot carrier diode has, in a few short years, proven its performance and reliability in major U.S. space programs and in critical instrument and industrial applications.

New production techniques have reduced the cost of these devices making them available for applications in TV tuners, commercial communication limiters, detectors and mixers, and for multiplexing in signal processing. New families of general purpose Hot Carrier Diodes will be introduced in 1967.

### Microwave mixer diodes

The constantly growing line of HPA microwave mixer and detector diodes described on page 164 is also available in matched pairs and matched quads. The 2350 Series is designed for use to 2.5 GHz, the 2520 Series for use to 6 GHz

and the 2600 Series for use through 8 GHz. A new X-band series will be introduced soon.

### Microwave switches/ variable attenuators

Since introducing its first microwave reflective switch two years ago, HPA has developed a broad line to meet the requirement of today's varied applications for solid-state switch/attenuators. In addition to their unique combined features of broad bandwidth, fast switching speed, high isolation, and high reliability, HPA microwave switches are available with Type N, TNC, OSM, and stripline connector styles. HPA also offers single-pole-single-throw and single-pole-double-throw configurations. Early in 1967, HPA will introduce a new series of coaxial switches using a modular construction approach making possible N pole-N throw switching.

### The state of the art

The significant new products mentioned here have already been developed and tested at HP Associates and will be introduced during the next few months. Many more are in development and will be announced throughout 1967. Look to HPA for continued leadership in solid-state technology.

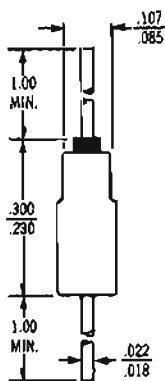

STYLE 11

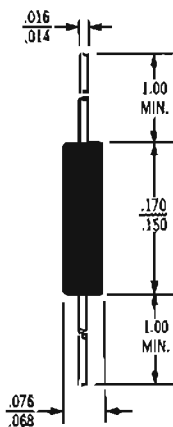

STYLE 15

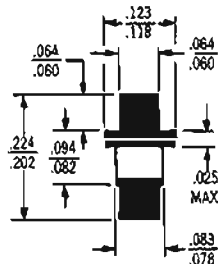

STYLE 31

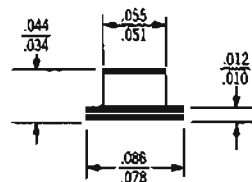

STYLE 38

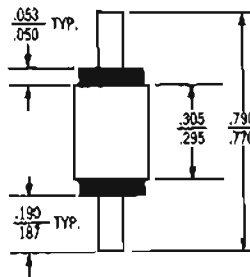

STYLE 20

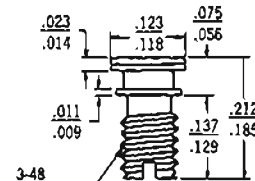

STYLE 40

STANDARD HPA PACKAGE STYLES

# STEP RECOVERY DIODES

Pulse generation, shaping and pulse delay  
Single stage, x 10, frequency multiplication



## SOLID-STATE DEVICES

The HPA Step Recovery Diodes are epitaxial, surface-passivated silicon devices with abrupt junctions. Process control of the very abrupt junction gradient permits controlled charge storage. Environmental tests are performed to insure that they will meet the latest revisions of MIL-STD-750, MIL-STD-202, and MIL-S-19500.

These Step Recovery Diodes, while conducting in the forward direction, store charge. When the reverse drive voltage depletes the stored charge (Figure 1), the diode appears as a high impedance. During this high impedance condition, a voltage impulse is generated (Figure 2). These pulses occur at a rate equal to the drive frequency. When this series of pulses is terminated in a resistive load, a comb spectrum is generated (Figure 3). By terminating the pulses in a resonant load, the spectrum is optimized at the desired output frequency for harmonic generation (Figure 4).

This device allows highly efficient generation of power at frequencies up to 12 GHz. The Step Recovery Diode thus allows an exceptionally stable signal source by having the driving source a crystal oscillator.

The Step Recovery Diode, as a pulse generating device, can provide pulses with less than 1 nanosecond rise and fall times and pulse amplitudes in excess of 10 volts into 50 ohms. The pulse repetition rate is equal to that of the driving signal. Pulse sampling, stretching, storage and shaping can also be accomplished using extremely simple circuitry.

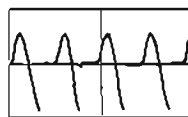

Figure 1. Step Recovery Diode Current

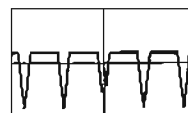

Figure 2. Step Recovery Diode Voltage

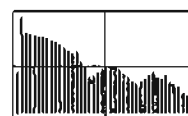

Figure 3. Comb Generation

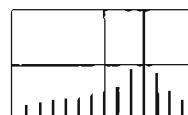

Figure 4. Harmonic Generation

HPA Device	Package Style	$V_F$ @ $I_F$ Max.	$C_O$ Max.	$BV_R$ Min.	$I_R$ @ $V_R$ Max.	$\tau$ Min.	$t_t$ @ $I_F$ Max.	$\theta$ Max.	
		V	pF	V	mA	ns	ps	$^{\circ}C/W$	
0112	11	1.0	150	3.0	35	50	300	15	300
0132	31	1.0	150	3.0	35	50	300	15	100
0113	11	1.0	200	10.0	35	50	500	10	300
0133	31	1.0	200	10.0	35	50	500	10	75
0114	11	1.0	300	10.0	35	50	400	10	300
0134	31	1.0	300	10.0	35	50	400	10	75
0151	15	1.0	40	1.6	15	10	150	15	600
0251	31	1.0	40	1.6	15	10	150	15	250
0152	15	1.0	40	2.1	15	10	150	15	600
0252	31	1.0	40	2.1	15	10	150	15	250
0153	15	1.0	40	1.1	25	10	150	15	600
0253	31	1.0	40	1.1	25	10	150	15	250
0154	15	1.0	40	1.1	25	10	200	15	600
0254	31	1.0	40	1.1	25	10	200	15	250
0180	11	1.0	250	8.0	65	10	500	10	300
0240	31	1.0	450	8.0	65	10	500	10	60
0181	11	1.0	350	8.0	65	10	500	10	300
0241	31	1.0	600	8.0	65	10	500	10	60
0182	15	1.0	75	2.0	35	10	200	15	600
0242	31	1.0	100	2.0	35	10	200	15	100
0183	15	1.0	125	2.0	35	10	150	15	600
0243	31	1.0	150	2.0	35	10	150	15	100
TEST CONDITIONS				$V_R = 0 V$ $f = 1 MHz$	$I_R = 10 \mu A$		$I_F = 1.7 I_R$		Note 1

Note 1:  $P_{Diss} = \frac{175^{\circ}C - T_A}{\theta}$  HPA Style 11 and 15 packages are mounted on a printed circuit board in still air; HPA Style 31 package is mounted on an infinite heat sink.

HPA Device	Package Style	$P_{out}$ @ 2 GHz	$V_F$ @ $I_F$ Max.	$C_O$		$C_{VR}$		$BV_R$ Min.	$\tau$ Min.	
		W	V	pF Min.	pF Max.	pF Min.	pF Max.	V	ns	
0300	40	2.0	1.1	1000	3.0	11.0	2.5	6.5	65	100
TEST CONDITIONS		$P_{in} = 15 W @ 200 MHz$			$f = 1 MHz, V_R = 0 V$		$f = 1 MHz, V_R = 10 V$	$I_R = 10 \mu A$	$I_F = 1.7 I_R$	



## HOT CARRIER DIODES

For high speed switching and microwave mixing applications

### Microwave mixing diodes

#### Advantages:

- Low and stable noise figure
- High tangential sensitivity
- Uniform and repeatable RF characteristics
- High pulse burnout resistance
- Large dynamic range at high LO powers

Microwave mixer diodes employing metal semiconductor (Schottky) barriers offer improvements in noise figure, reliability, and dynamic range when compared to conventional point contact diodes. Conversion loss and noise figure are 1 to 2 dB lower than corresponding parameters of the best available

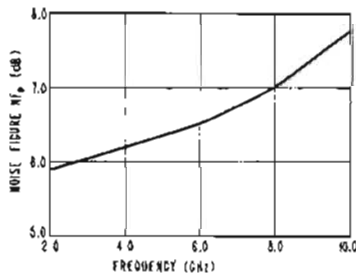

Figure 1. Typical noise figure vs. frequency (2600 series).  
 $P_{LO} = 1 \text{ mW}$   $f_{IF} = 30 \text{ MHz}$   $NF_{IF} = 1.5 \text{ dB}$

point contact microwave devices and 1/f noise is better than 25 dB lower. Ruggedness, both physical and electrical, is superior, as is the basic device reliability. Consistent mixer performance can be readily attained with HPA Microwave Mixer Diodes because of (1) the relative ease with which they can be matched to 50 ohms and (2) the uniformity of the product resulting from advanced production techniques.

HPA Device	Package Style	SSB Noise Figure NF (dB Max.)	IF Impedance $Z_{IF}$ (ohms)	Typical RF Impedance (VSWR)
2350	15	7.0	150-250	1.5
2365	15	6.5	150-250	1.3
2520	15	7.0	100-250	1.5
2550	15	6.5	100-250	1.5
2565	15	6.0	100-250	1.5
2602	15	7.0	125-250	1.5
2603	15	7.5	125-250	1.5

NF test: 2300; RF = 2 GHz, IF = 30 MHz,  $P_{LO} = 1 \text{ mW}$ ,  $NF_{IF} = 1.5 \text{ dB}$   
 NF test: 2500; RF = 3 GHz, IF = 30 MHz,  $P_{LO} = 1 \text{ mW}$ ,  $NF_{IF} = 1.5 \text{ dB}$   
 NF test: 2600; RF = 8 GHz, IF = 30 MHz,  $P_{LO} = 1 \text{ mW}$ ,  $NF_{IF} = 1.5 \text{ dB}$

### Switching diodes

#### Advantages:

- Majority carrier conduction
- Low leakage
- High conductance
- Low forward threshold voltage
- High pulse power capability

These diodes utilize a closely controlled metal semiconductor junction which provides virtual elimination of charge storage. The result is extremely fast turn-on and turn-off times with excellent diode forward and reverse characteristics. This process results in lower noise characteristics and wider dynamic range (conversion loss and noise figure are relatively insensitive to local oscillator power variations over the range of 0.5

mW to 20 mW). They are especially useful for mixer and detector applications to improve receiver sensitivity. Improved resolution in ultra-high speed sampling and switching networks is possible by combining the pico-second lifetimes, low capacitance and excellent forward to reverse characteristics of the device.

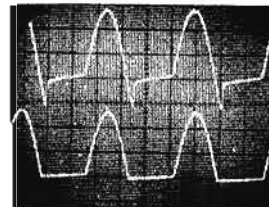

Figure 2. Comparison of recovery time of the Hot Carrier Diode (lower trace) with a conventional high speed 1 nsec switching diode (upper trace). Sweep speed, 10 nsec/cm; vertical sensitivity, 20 mA/cm; applied signal, 30 MHz sine wave.

HPA Device	Package Style	Forward Voltage $V_{F1}$	Forward Voltage $V_{F2}$	Breakdown Voltage $BV_R$	Leakage Current $I_R$	Capacitance $C_D$	Effective Minority Carrier Lifetime <sup>2</sup> $\tau$	Price 1-99
2301 (Min.)	15	1.0 V	0.4 V	30 V	300 nA	1 pF	100 ps	\$8.50
2302 (Min.)	15	1.0 V	0.4 V	30 V	300 nA	1 pF	100 ps	\$7.75
2303 (Min.)	15	1.0 V	0.4 V	20 V	500 nA	1.2 pF	100 ps	\$7.15
2900 (Min.) (Max.)	15	1.0 V	0.4 V	10 V	100 nA	1.5 pF	120 ps	\$3.00
Test Cond.		(1)	$I_F = 1 \text{ mA}$	$I_R = 10 \mu\text{A}$	(3)	$V_R = 0 \text{ V}$ $f = 1 \text{ MHz}$		

<sup>1</sup> $I_F = 50 \text{ mA}$  for HPA 2301; 35 mA for HPA 2302/3; and 20 mA for HPA 2900.

<sup>2</sup>These diodes are too fast to measure in conventional circuits utilizing standard reverse recovery time measurements. Therefore, the effective minority carrier lifetime is specified as  $\tau$  instead of  $T_{rr}$ . Devices are hermetically sealed in a miniature glass package, 0.160" long, 0.070" in diameter, digitally coded.

<sup>3</sup> $V_R = 15 \text{ V}$  for HPA 2301/2/3 and 5 V for HPA 2900.



# HIGH CONDUCTANCE AND PIN DIODES



## SOLID-STATE DEVICES

### HIGH CONDUCTANCE DIODES

#### Advantages:

- High conductance
- Low capacitance
- Nanosecond turn-on and turn-off

The HPA 1000 Series of High Conductance Diodes feature planar silicon epitaxial construction to provide high conduc-

tance, low capacitance, and nanosecond turn-on and turn-off. Process control of the diode manufacture enables specification of effective minority carrier lifetime. Turn-on time and voltage overshoot are minimized in these diodes of low conductivity modulation. These diodes are ideally suited for applications such as thin film memory drives, pulse generation, input gates, or wherever high conductance is required without loss of speed.

HPA Device	Package Style	Forward Current $I_{F1}$ Min.	Forward Current $I_{F2}$ Min.	Breakdown Voltage $BV_R$ Min.	Reverse Current $I_{R1}$ Max.	Reverse Current $I_{R2}$ Max. (160° C)	Capacitance $C_s$ Max.	Reverse Recovery Time $t_{rr}$ Max.	Turn-on Time $t_{on}$ Max.	Lifetime $\tau$ Max.	Lifetime $\tau$ Typ.	Rectification Efficiency R.E. Typ.
1001	11	150 mA	500 mA	35 V	200 nA	200 $\mu$ A	1.5 pF	1.5 ns	2.5 ns	500 ps	350 ps	65%
1002	11	300 mA	800 mA	35 V	200 nA	200 $\mu$ A	3.0 pF	2.0 ns	2.5 ns	500 ps	350 ps	65%
1003	11	100 mA	300 mA	25 V	200 nA	200 $\mu$ A	2.0 pF	1.5 ns	2.0 ns	500 ps	350 ps	65%
1004	11	200 mA	600 mA	25 V	200 nA	200 $\mu$ A	4.0 pF	2.0 ns	2.0 ns	500 ps	350 ps	65%
1006	11	150 mA	500 mA	50 V	200 nA	200 $\mu$ A	1.1 pF	1.5 ns			350 ps	65%
Test Conditions		$V_F = 1.0$ V (Note 1)	$V_F = 1.4$ V (Note 1)	$I_R = 10$ $\mu$ A	(Note 2)	(Note 2)	$V_R = 0$ V $f = 1.0$ MHz					

Note 1: Measured at a repetition rate not to exceed the power dissipation.

Note 2:  $V_R = 35$  V for 1006;  $V_R = 30$  V for 1001, 1002;  $V_R = 20$  V for 1003, 1004.

### PIN DIODES

#### Advantages:

- New method of modulating/switching microwave signals.
- Surface passivated for improved stability and reliability.

These devices make possible a new method of modulating microwave signals. When placed across a transmission line, the device acts as an absorption-type attenuator and allows sine-wave, square-wave and pulse modulation with no frequency pulling of the signal source. Turn-on times of less than 20 nsec for an on-off ratio of greater than 30 dB are possible. Planar passivation insures long-term stability and reliability. The HPA PIN diodes are especially useful where the lowest possible residual series resistance and junction capacitances are required for high on-to-off switching ratios.

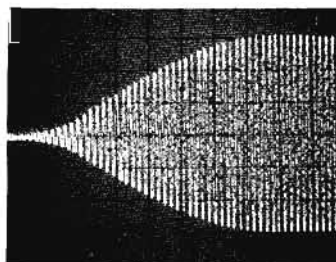

This oscillograph shows a 100 mV RF carrier modulated by PIN diodes. It is shown turning on in less than 20 nsec. Sweep speed is 5 nsec/cm.

HPA Device	Package Style	Breakdown Voltage $BV_R$	Forward Voltage $V_F$	Total Capacitance $C_{VR}$	Series Resistance $R_s$	Lifetime $\tau$	Price 1-9 10-99
3001	15	150	1.0	.30	2.5	100	\$13.35 11.35
3002	15	200	1.0	.30	2.5	100	15.65 13.30
3101	38	150	1.0	.32	2.5	100	27.00 23.00
3102	38	200	1.0	.30	2.5	100	30.00 25.50
3201	31	150	1.0	.35	2.5	100	22.00 18.75
3202	31	200	1.0	.32	2.5	100	25.00 21.25
Units		V min.	V max.	pF max.	$\Omega$ max.	nsec. min.	
Test Conditions		@10 $\mu$ A	Note 1	@-50 V	$I_F = 50$ mA	$I_F = 50$ mA	

Note 1: Forward voltage specification is at 100 mA for the HPA 3001, 3101, and 3201; 150 mA for the HPA 3002, 3102, and 3202.

**Advantages:**

- DC to over 15 GHz bandwidth
- High isolation, low insertion loss
- N, TNC, OSM and stripline connector styles
- SPST and SPDT configurations

Now you can avoid costly design trade-offs such as power for performance by designing in devices from the growing line of HPA microwave switches/variable attenuators. A new HPA microwave switch design concept sharply reduces parasitic reactances, improves thermal resistance, extends bandwidth from 200 MHz to over 15 GHz, improves isolation/insertion loss ratios to 45:1, and increases power handling capability. You get this high performance in both single-pole, single-throw and single-pole, double-throw units. They were designed as standard devices to provide widely useful performance, rather than as specials with limited operational ranges.

These switches are ideally suited for applications such as Pulse Modulators, Amplitude Modulators, Phase Shifters, Phased Array Antennas, T-R Switches, Limiters, Attenuators, AGC Circuits, Power Leveling Circuits, Redundant Microwave Systems, Synthesizers, Antenna Lobing and ECM receiver switching. Environmental ratings of all units have been established to accommodate requirements of applicable MIL specifications.

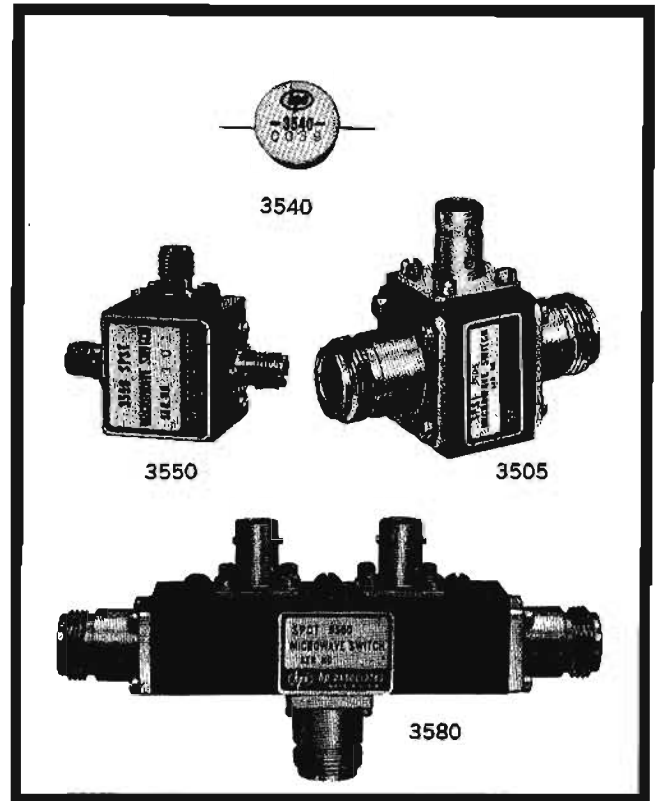

HPA device	Bias terminal	RF terminal	Bias polarity for switch OFF	Frequency range	Switching time	Insertion loss	Isolation	Price 1-8
3501	BNC	TNC	Pos.	200 MHz to over 12.4 GHz	100-300 ns	.5 to 1.5 dB	25 to 45 dB	\$275
3503	BNC	N	Pos.	200 MHz to over 12.4 GHz	100-300 ns	.5 to 1.5 dB	25 to 45 dB	275
3504	BNC	TNC	Neg.	200 MHz to over 12.4 GHz	100-300 ns	.5 to 1.5 dB	25 to 45 dB	275
3505	BNC	N	Neg.	200 MHz to over 12.4 GHz	100-300 ns	.5 to 1.5 dB	25 to 45 dB	275
3530	Stripline integrated unit, wire leads for RF terminals.		Neg.	DC to over 12.4 GHz	50 ns	.5 to 1.5 dB	25 to 45 dB	175
3540			Pos.		10 ns	.5 to 2dB		
3550	OSM	OSM	Pos.	200 MHz to over 12.4 GHz	100-300 ns	.5 to 1.5 dB	25 to 45 dB	325
3551	OSM	OSM	Neg.	200 MHz to over 12.4 GHz	100-300 ns	.5 to 1.5 dB	25 to 45 dB	325
3570	BNC	TNC	Pos.	1 GHz to 12.4 GHz	10 ns	1.5 to 2.0 dB	30 to 35 dB	275
3571	BNC	N	Pos.	1 GHz to 12.4 GHz	10 ns	1.5 to 2.0 dB	30 to 35 dB	275
3580	BNC	N	Neg.	4 GHz to 8 GHz (SPDT)	15 ns	1.5 to 2.5 dB	70 to 90 dB	495

VSWR (Switch ON) all units 2.0:1 max. Prices f.o.b. factory; prices in quantities of 10-24 and 25-99 upon request.

## PHOTOCONDUCTOR DEVICES

Photochoppers, photomodulators,  
photo controlled resistors



## SOLID-STATE DEVICES

### Advantages:

- Long life
- Low noise and offset
- High efficiency
- Low driving power consumption
- High stability
- Large dynamic range

The high-performance photoconductor components developed and utilized in Hewlett-Packard's own chopper and chopper-stabilized dc amplifiers and switches are now commercially available, featuring Hewlett-Packard's standard reliability and optimum performance in terms of temperature, speed, offset and drift.

The basic photoconductor used in these photochoppers, modulators, and photo-controlled resistors (PCR's) was developed through years of intense use in numerous HP amplifiers and switches and is still the "heart" of HP Associates' family of photoconductor components.

The photocells are illuminated with self-contained neon glow lamps, stabilized and selected to provide long life and reliable operation. The photochoppers contain two synchronous SPDT switches for applications requiring series-shunt modulation and demodulation, while the photomodulators contain one SPDT switch for applications requiring modulation only. The PCR's are ideally suited for applications where SPST switching is required. All of the devices offer wide dynamic range, low driving power consumption, long life and freedom from drift.

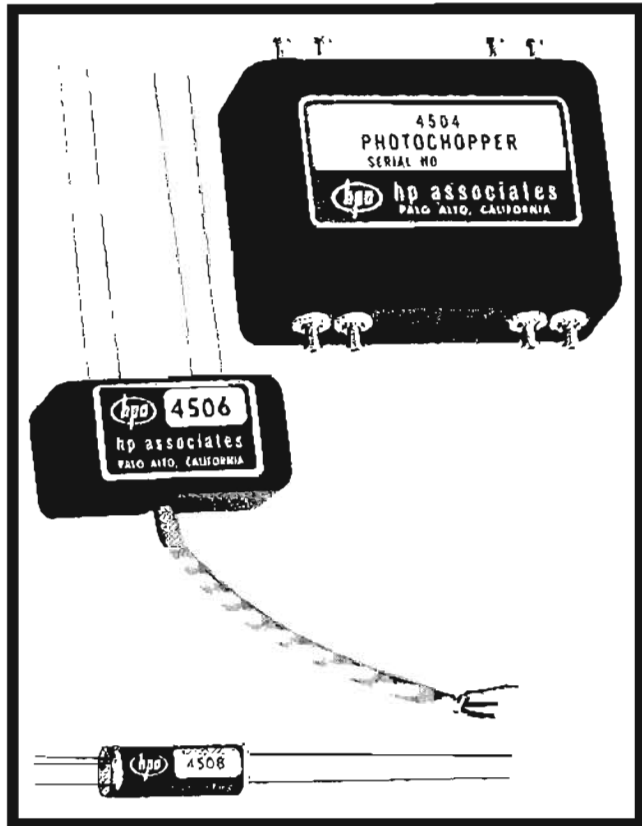

HPA Device	Description	Typical Impedances		Drive	Price	
					1-9	10-99
4501	DPDT 4-cell Mod/Demod Internal Oscillator High Z Modulator	Mod. Input Mod. Output Demod. Output	1.25 MΩ 125 kΩ 25 kΩ	250 V, 2.5 mA DC Internal Oscillator 225 Hz	39.50	33.50
4502	DPDT 4-cell Mod/Demod Internal Oscillator Low Z Modulator	Mod. Input Mod. Output Demod. Output	150 kΩ 7.5 kΩ 25 kΩ	250 V, 2.5 mA DC Internal Oscillator 95 Hz.	39.50	33.50
4503	DPDT 4-cell Mod/Demod for Ext. Oscillator High Z Modulator	60 Hz. chopping freq. Mod. Input Mod. Output Demod. Output	5 MΩ 125 kΩ 30 kΩ	170 V peak 2.5 mA 1 kHz max.	37.50	32.00
4504	DPDT 4-cell Mod/Demod for Ext. Oscillator Low Z Modulator	60 Hz chopping freq. Mod. Input Mod. Output Demod. Output	200 kΩ 5 kΩ 30 kΩ	170 V peak 2.5 mA 1 kHz max.	37.50	32.00
4505	SPDT 2-cell Mod. only High Z	200 Hz chopping freq. Mod. Input Mod. Output	2 MΩ 125 kΩ	170 V peak 2.5 mA 1 kHz max.	22.50	19.00
4506	SPDT 2-cell Mod. only Low Z	200 Hz chopping freq. Mod. Input Mod. Output	75 kΩ 5 kΩ	170 V peak 2.5 mA 1 kHz max.	22.50	19.00
4507	SPST PCR High Z	"ON" R "OFF" R	150 kΩ Min. 100 MΩ	150 V peak 1 kHz max.	8.00	6.80
4508	SPST PCR Low Z	"ON" R "OFF" R	6.8 kΩ Min. 100 MΩ	150 V peak 1 kHz max.	8.00	6.80



The three products described here represent the latest additions to HPA's broad line of optoelectronic devices. Infrared sources, PIN photodiodes and photon coupled isolators are available in different packages designed for optimum performance in a variety of applications. For complete specifications on these versatile components, contact the Hewlett-Packard office nearest you.

GaAs Infrared Sources		PIN Photodiodes		Photon Coupled Isolators	
HPA Device	Package Style	HPA Device	Package Style	HPA Device	Package Style
4104	A	4201	A	4301	D
4106	B	4203	B	4303	E
4107	C	4204	B	4310	F
		4205	C		

**HPA 4107 gallium arsenide infrared source**

The HPA 4107 is a gallium arsenide electroluminescent diode which, when forward biased, radiates infrared light in a narrow band at about 9000 Angstroms, at very high intensity.

The diode is contained in a low capacitance Kovar and ceramic package of extremely small dimensions.

The HPA 4107 can be used in conjunction with the HPA 4205 to form a fast photon coupled pair for convenient use in card and tape readers, encoders, and similar applications.

**Light emission characteristics at 25°C**

	At I = 5 mA	At I = 60 mA	Units
Quantum Emission Efficiency	0.001 typical	0.002 typical	Photons/elec.
Total Power Output	5 typical	75 typical	Microwatts

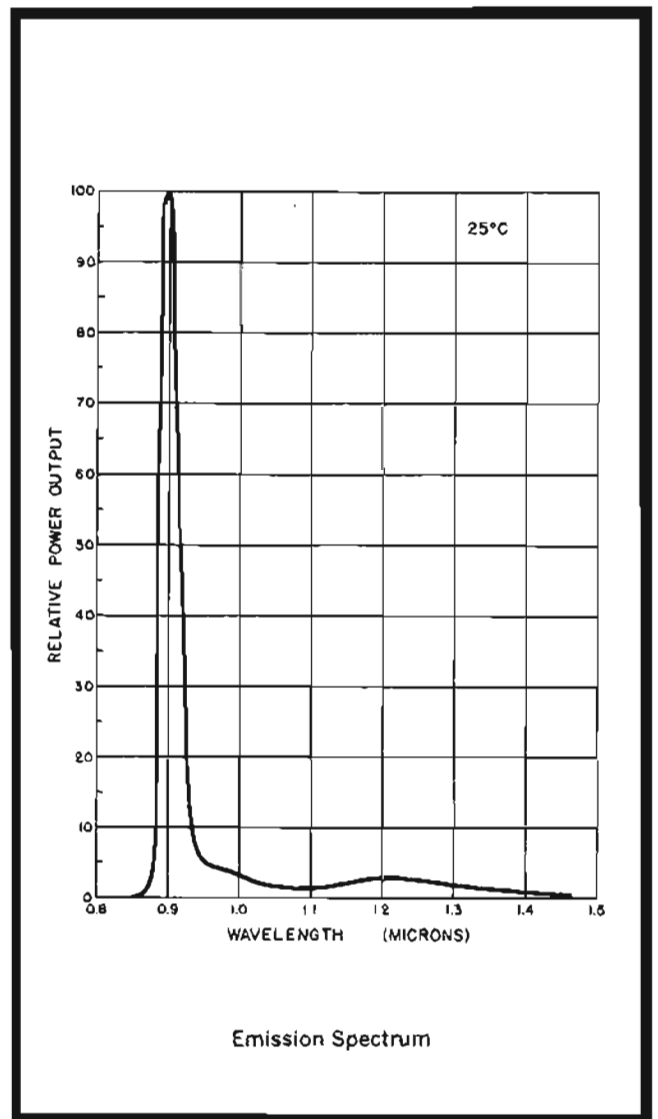
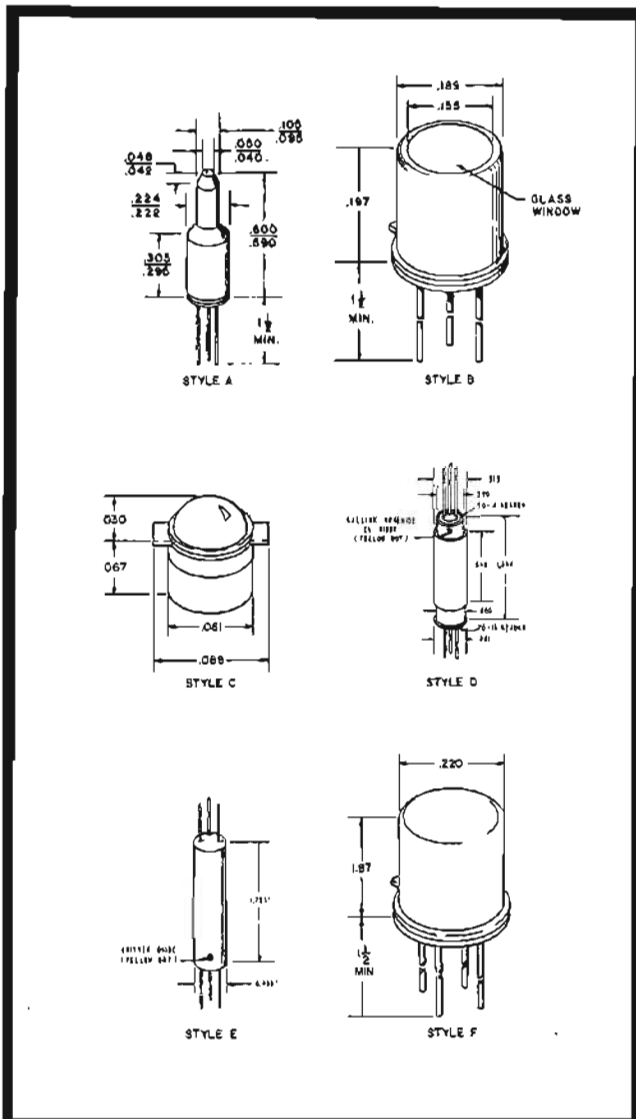



### HPA 4205 ultrafast, low-noise silicon PIN photodiode

The HPA 4205 is a silicon planar PIN photodiode for detection of light in the visible and near infrared regions. Response to blue and violet light is unusually good for a very low dark current silicon photodiode. Speed of response of this diode is less than 1 nanosecond and laser pulses as short as 0.1 nanosecond may be observed. The frequency response extends from dc to 1 GHz. The low dark current of less than 150 picoamperes enables detection of very low light levels. The quantum detection efficiency is constant over six decades of light intensity, providing excellent dynamic range.

#### Optical characteristics

		Test Conditions
Response at 7700 Å	0.75 electrons/photon 0.25 $\mu\text{A}/\text{mW}/\text{cm}^2$ 0.5 $\mu\text{A}/\mu\text{W}$	$V = -20\text{ V}$ $R_L = <1\text{ M}\Omega$
Sensitive Area	$0.5 \times 10^{-3}\text{ cm}^2$ 0.010" diameter	
Speed of Response	Less than 1 nanosecond	

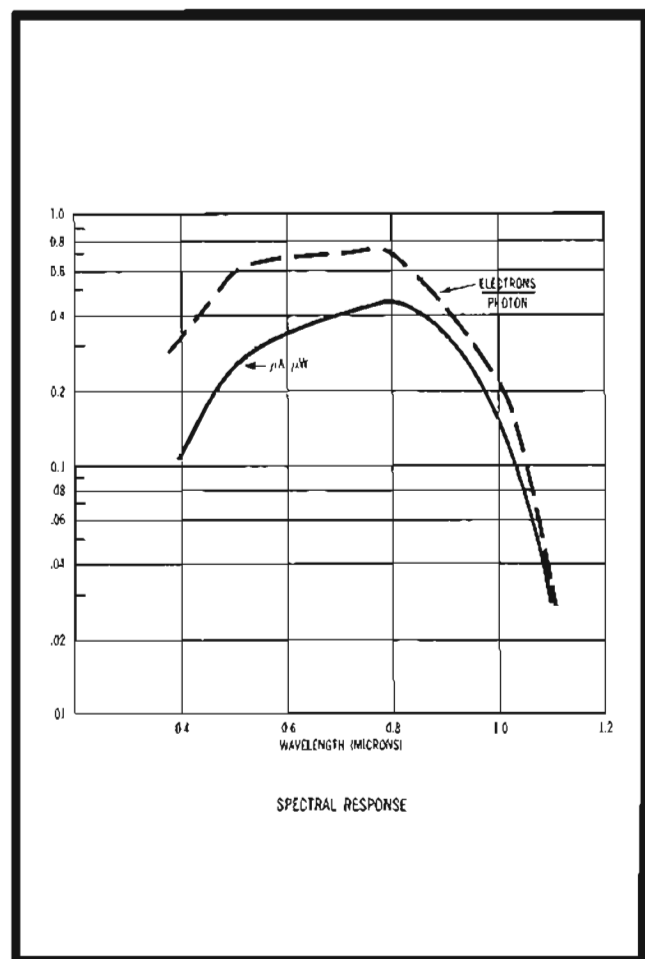

### HPA 4310 Photon Coupled Isolator

The HPA 4310 Photon Coupled Isolator is a wide bandwidth dc coupling device consisting of a gallium arsenide electroluminescent diode infrared source and a silicon PIN photodetector. Electrical input signals are applied to the GaAs diode, which emits infrared radiation in proportion to the instantaneous forward current. This radiation is detected by the photodiode, which is well insulated from the emitter. The electrical signals resulting at the photodiode can thereby be controlled from an input in a separate and electrically isolated circuit. The isolation between input and output is typically  $10^{11}\Omega$ , shunted by 2 picofarads. The device will operate on both ac and dc signals and has a bandwidth of 3.5 MHz. It is designed to provide isolation up to 200 volts dc. The isolator is packaged on a TO-18 header with four leads. The anode of the input diode is electrically connected to the case.

#### Transfer characteristics at 25°C

		Test Conditions
DC Current Transfer Ratio, $\frac{I_2}{I_1}$ $I_1 =$ emitter diode input current $I_2 =$ photodiode output current $V_2 =$ voltage across photodiode	0.002 typical	$I_1 = 30\text{ mA}$ $V_2 = -25\text{ V}$
Cut-off frequency of current transfer	3.5 MHz	
Capacitive coupling, case grounded	2 pF typical	
Resistive coupling	$10^{11}\Omega$ typical	
Breakdown Voltage, emitter to detector	> 200 V working	

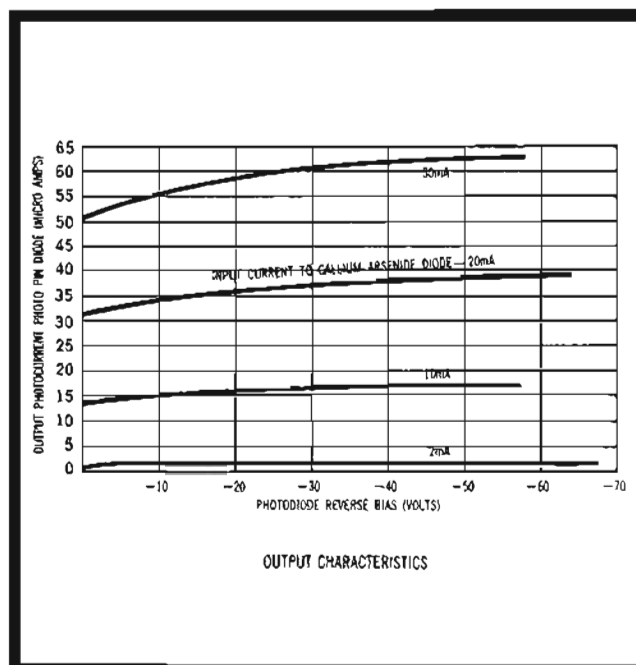



The latest innovations in instruments with up to  $\pm 0.002\%$  accuracy in normal working environments demand working standards with better accuracy; and this accuracy must be maintained outside the standards laboratory. Hewlett-Packard has developed a line of working standards and calibrators to meet the accuracy requirements from  $\pm 0.002\%$  up to  $\pm 3\%$ .

**Traceable to NBS**

The absolute accuracy of Hewlett-Packard's working standards and calibrators is traceable to the National Bureau of Standards, as shown in the flow chart, Figure 1. Special care has been taken to develop instruments with state-of-the-art stability so that specified accuracy and traceability can be maintained for long periods of time.

**Adjustable standard resistors**

A new type of standard resistor construction has been developed by HP in which the resistor coil is supported between two layers of polyester, eliminating the brass form of earlier standard resistors. In this way, the temperature coefficient of the main resistor coil is essentially the same as that of the unsupported resistance wire.

Figure 2 shows the circuit diagram of these adjustable standard resistors. The total resistance of these standard resistors is from 1 k ohms to 100 k ohms. R1 and R2 both change in value as the total resistance changes so that the 50-ohm variable resistor gives a range of adjusta-

bility approximately  $\pm 25$  ppm of resistor values. The adjustable resistor has no significant effect on the stability or the temperature coefficient of the entire resistance. Refer to page 172 of this catalog for further information on the HP adjustable standard resistors.

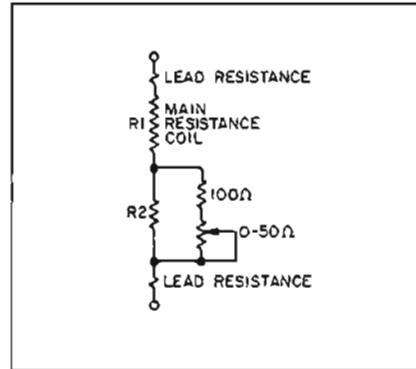

Figure 2. Std. Resistor Circuit

**Reference diodes**

The long-term accuracy and stability of the Hewlett-Packard working standards are dependent on selected Zener diodes. Three distinct steps are necessary to provide a reliable reference diode; 1) process control in its original fabrication, 2) design of a compatible circuit, and 3) a 100% test of the completed circuit.

To achieve the stability and accuracy necessary for the HP dc working standards, a selected Zener diode and its associated circuitry is housed in a temperature-controlled oven. The inner-oven

temperature is held nominally at  $80^\circ\text{C} \pm 0.01^\circ\text{C}$  during normal room variations. Figure 3 shows the simplified circuitry within the oven.

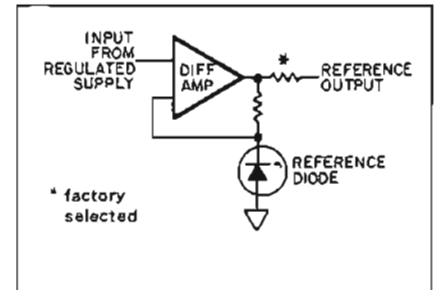

Figure 3. Oven Reference Supply

The HP 735A Transfer Standard uses this reference supply to obtain accurate stable voltages of 1.000 volt, 1.018 to 1.020 volts and 0 to 1000  $\mu\text{V}$ . It is quickly calibrated by a front-panel adjustment using a standard cell (or another 735A) and a null meter.

The HP 740B and 741B DC Standards use the oven reference supply for a reference voltage to generate the 0 to 1000 volt accurate, stable output. This reference voltage is applied to a precision resistive divider which is the input to an amplifier chain, as shown in Figure 4.

The summing point compares the input of the amplifier to an attenuated

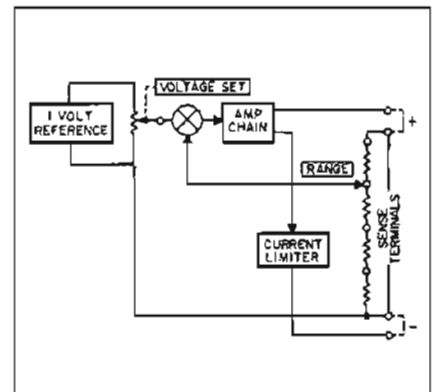

Figure 4. HP DC Standards Simplified Diagram

sample of the output, taken from the range voltage divider. The current limit control is nominally adjusted for the protection of the output load.

Table 1 shows available HP dc Standards (0-1000 volts).

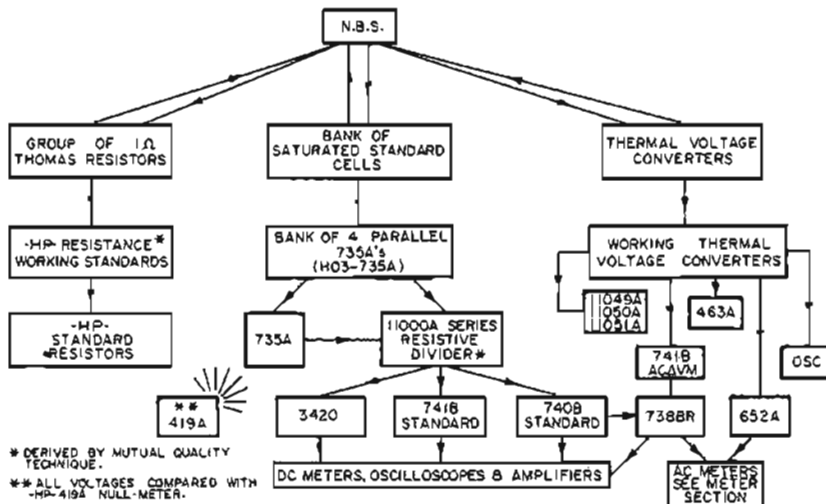

Figure 1. HP Instrument Traceability to NBS

\* DERIVED BY MUTUAL QUALITY TECHNIQUE.  
 \*\* ALL VOLTAGES COMPARED WITH -HP- 419A NULL-METER.

Table 1—HP DC Standards

Features	Model 740B	Model 741B
Ranges	0-1000 V in 4 decades	0-1000 V in 4 decades
Accuracy	= (0.002% setting + 0.0004% range)	= 0.01% of setting or ± 0.001% of range
Stability	= (5 ppm setting + 1 ppm range/day)	= (10 ppm setting + 1 ppm range/day)
Readout	5 digital display tubes + meter	4 digit display + meter
Floating	Yes	Yes
Current Limit	5-50 mA (nominal)	4-20 mA (nominal)
Remote Sensing	Yes	Yes
Guarding	Yes	No
Recorder Output	1 V dc nominal into 1 kΩ load DC	1 V dc nominal into 1 kΩ load AC and DC
Differential Voltmeter	Bonus (refer to Page 212) DC	Bonus (refer to Page 213) AC and DC
High Z VM	Bonus (refer to Page 212) DC	Bonus (refer to Page 176) AC and DC
Amplifier	Bonus (refer to Page 174)	Bonus (refer to Page 176)

**Thermal converters**

Hewlett-Packard Thermal Converters are true rms detectors, yielding a dc output proportional to the temperature rise resulting from the ac input power. The Models 11049A, 11050A and 11051A offer an exceptionally flat response and nearly constant impedance over a fre-

quency range of 5 Hz to 10 MHz. A quick way of checking the frequency response of a voltmeter calibrator, an oscillator or an ac amplifier is to connect its output to a thermal converter. The output of the thermal converter is then monitored by the use of a dc standard and a null meter.

**AC/DC Meter calibration systems**

The HP E02-738BR voltmeter calibration system includes the Model 652A Test Oscillator and the Model 738BR Voltmeter Calibrator, mounted in a convenient cabinet. This system was designed specifically for calibrating high impedance voltmeters and oscilloscopes.

The 738BR provides a 400 Hz rms or peak-to-peak ac voltage and a dc voltage output from 300 μV to 300 V. The accuracy is better than 0.1% dc and 0.2% ac. The 652A provides a frequency response, by using the EXPAND position of the meter, from 10 Hz to 10 MHz with a flatness of ±0.25%.

The HP Harrison Division MODEL 6920B Meter Calibrator is an easily portable, simple device used to calibrate ac and dc meters from 0.01 V to 1 kV, and from 0.01 mA to 5 amperes. The output setting of voltage or current is adjusted by means of a three-digit, ten-turn readout on any volt, milliampere or ampere range. The dc accuracy is 0.2%, and ac accuracy is 0.4% of output.

The following chart shows the features of the E02-738BR and the Harrison 6920B AC/DC Meter Calibrators.

Table 2—HP ac/dc meter calibrators

Features	E02-738BR (Refer to Page 179)	Harrison 6920B (Refer to Page 178)
DC Voltage Accuracy Range	Yes = (0.1% + attenuator 0.1%) 300 μV to 300 V	Yes = (0.2% of output + 1 digit) 0.01 V to 1000 V
AC Voltage Frequency Accuracy Range	Yes 400 Hz = (0.2% + attenuator 0.1%) 300 μV to 300 V	Yes 58-62 Hz (power line) = (0.4% of output + 1 digit) 0.01 V to 1000 V
Frequency Response Accuracy Frequency Range	Yes ± 0.25% 10 Hz to 10 MHz	No
DC Current Accuracy Range	No	Yes = (0.2% of output + 1 digit) 1 μA to 5A
AC Current Frequency Accuracy Range	No	Yes 58-62 Hz (power line) = (0.4% of output + 1 digit) 10 μA to 5A

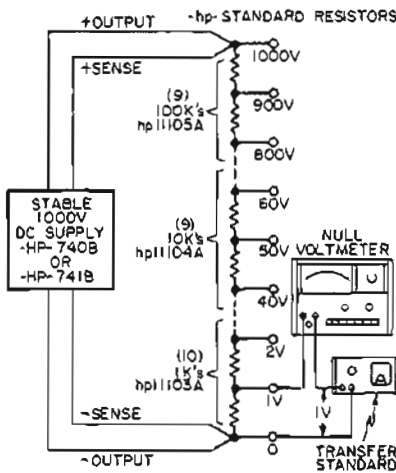

Figure 5. 1 V to 1000 V, accuracy ± 6 ppm.

Figure 5 shows a combined use of HP Standards equipment capable of having a dc voltage output of 1 V to 1000 V in 1 volt steps to 10 volts, 10 volt steps to 100 volts, and 100 volt steps to 1000 volts with an accuracy of ± 6ppm or better. For other applications see Application Note 80.





## STANDARD RESISTORS

Accurate, stable and adjustable

Models 11103A, 11104A, 11105A

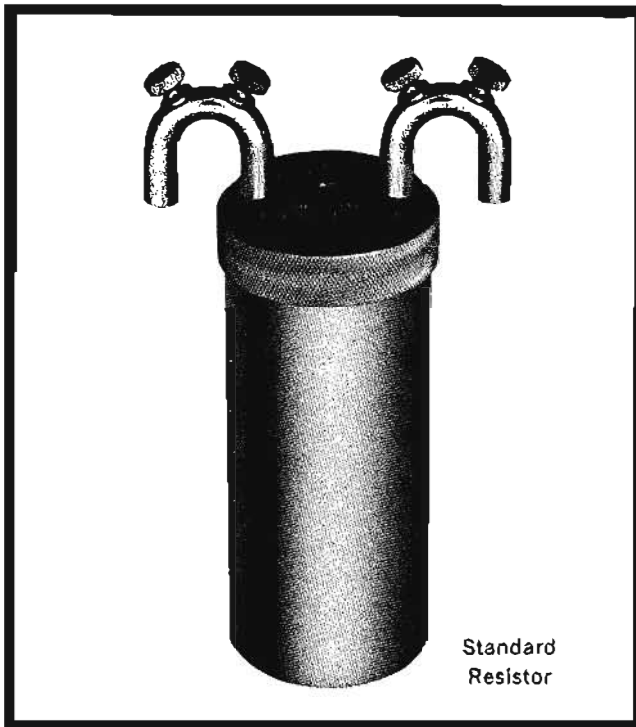

Standard Resistor

Hewlett-Packard Standard Resistors Models 11103A (1 k $\Omega$ ), 11104A (10 k $\Omega$ ), and 11105A (100 k $\Omega$ ) are all calibrated to within  $\pm 6$  parts per million of the legal ohm maintained by the National Bureau of Standards. These resistors are designed for use as standards in industrial, research and standards laboratories.

### Design construction

New construction techniques developed in Hewlett-Packard's standards laboratories have resulted in improvements in the stability characteristics of standard resistors. The resistors are made of selected Evenohm wire supported between polyester film. This eliminates the mechanical strain caused by differences in the temperature coefficients of the resistive element and the brass support structure. The coil of wire is immersed in moisture-free oil in a sealed, nickel-rhodium plated, brass can. The construction of the resistor permits immersion of the whole unit in oil for better temperature equalization. All connections in the resistor are silver soldered. The standard terminal hooks are made of oxygen-free copper that is nickel-rhodium plated.

### Resistors are adjustable

The adjustable range of HP's standard resistors is  $\pm 25$  parts per million with 0.3 ppm resolution. Adjustment can be made precisely with a jeweler's screwdriver to suit the measuring situation (e.g., setting voltage dividers by ratio matching), speeding results and greatly reducing the calculations required.

### Stability

The stability of a standard resistor is determined by observing the amount of change in resistance per unit of time. The stability specifications for the 11100 series standard resistors are given in ppm (of rated resistance) per year. The change in resistance is mainly due to the aging process of the resistor components. Stability of the resistor will generally improve with time, providing the resistor is not subjected to overload (greater than 0.1 watt power dissipation), and does not receive a severe mechanical shock.

### Traceability

Each Hewlett-Packard Standard Resistor is adjusted to its nominal value and checked for stability and temperature characteristics. The working standards used for these tests are checked periodically against laboratory reference standards which in turn, are calibrated at frequent intervals by the National Bureau of Standards.

### Calibration report

Alpha and Beta coefficients are individually determined and a calibration report is furnished with each resistor specifying traceability to NBS. The change in resistance for temperatures other than 25°C can be calibrated.

### Specifications

HP Model	Resistance
11103A	1 k $\Omega$
11104A	10 k $\Omega$
11105A	100 k $\Omega$

### Characteristics

HP Model	Resistance	Limit of Error*	Stability (ppm/year)	Temperature** Coefficient
11103A	1000 ohms	6 ppm	$\leq 10$	$\leq 4$ ppm/ $^{\circ}\text{C}$
11104A	10 k $\Omega$	6 ppm	$\leq 15$	$\leq 4$ ppm/ $^{\circ}\text{C}$
11105A	100 k $\Omega$	6 ppm	$\leq 20$	$\leq 4$ ppm/ $^{\circ}\text{C}$

Temperature coefficient:  $\pm 4$  ppm/ $^{\circ}\text{C}$ .†

Power rating: 0.1 watt.

Adjustment range:  $\pm 25$  ppm minimum.

Resolution: 0.3 ppm.

Connections: 4-terminal, NBS-type, oxygen-free copper that is nickel-rhodium plated.

Dimensions: diameter 17/8" (47,6 mm); height 6" (152,4 mm); hook span 33/8" (85,8 mm).

Weight: net 1.3 lbs (0,58 kg); shipping 2 lbs (0,9 kg).

Price: HP 11103A, 11104A and 11105A; \$75 each.

\*Calibrated at rated power (25°C) to within 6 ppm (0.0006%) with reference to the legal ohm maintained by the National Bureau of Standards.

\*\*Alpha and Beta values are furnished with each Standard Resistor for calculating its resistance at other temperatures.

†Included with each standard resistor are Alpha and Beta values used to calculate the resistance of the standard at temperatures other than 25°C.

## DC TRANSFER STANDARD

Portable instrument transfers std. voltages  
Model 735A



# WORKING STANDARDS

### Uses:

- 1 V reference for volt boxes and potentiometers
- Standard cell comparator
- Stable microvolt source

The HP 735A is a general-purpose laboratory transfer standard. It may be used as a 1 V standard output with standard cell accuracy, a standard cell comparator, or as a 0 to 1000  $\mu\text{V}$  standard source for dc and potentiometric measurements.

This guarded, high-accuracy transfer standard has 4 functions:

1.  $1.018 + \Delta^*$  reference for saturated standard cell comparisons.
2.  $1.019 + \Delta^*$  reference for unsaturated standard cell comparisons.
3. 1 V reference for volt box and potentiometric measurements.
4. 0 to 1000  $\mu\text{V}$  source with 1  $\mu\text{V}$  resolution.

### Reference supply

The basic stability of the 735A is derived from a reference supply enclosed in a proportionally controlled oven. The temperature of the reference diode is held to within  $\pm 0.03^\circ\text{C}$  for an ambient temperature of  $0^\circ$  to  $+50^\circ\text{C}$ . The reference supply maintains a stability better than 10 ppm/mo. The overall temperature and long-term stability of the 735A is assured by using HP-produced ultra-stable resistors with temperature coefficients matched to within  $0.5 \text{ ppm}/^\circ\text{C}$ .

### Circuit guard

The 735A Transfer Standard features a guard shield which isolates the floating output from the chassis.

### Transfer standard

The 735A can be disconnected from the power line for convenient transfer of a standard cell to working standards or directly to the piece of equipment to be calibrated, and will recover to within  $\pm 1 \text{ ppm}$  within 30 minutes warmup.

### Features:

- Voltage standard output
- Exceptional stability
- Short-circuit proof
- Very low temperature coefficient
- Direct-reading comparisons
- Low thermal emf
- Floating and guarded output
- Compact

\*A 3-digit direct-reading 0 to 1000  $\mu\text{V}$  offset voltage.

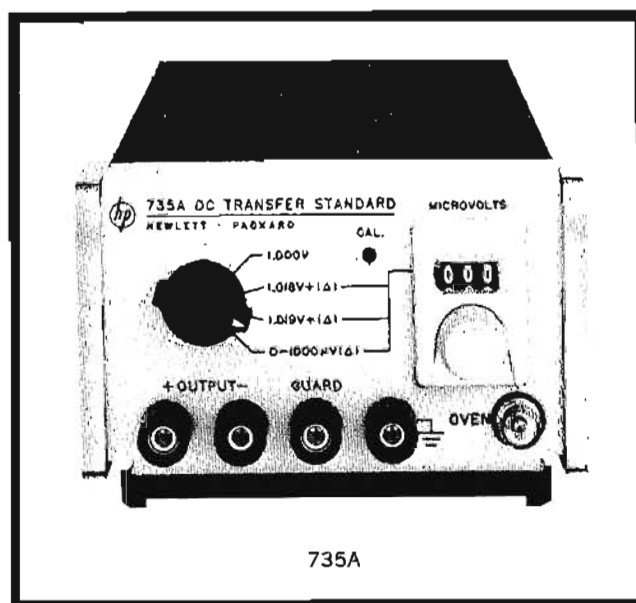

### Specifications

**Standard outputs:** 1.00000 V;  $1.018 + \Delta^*$ ;  $1.019 + \Delta^*$ ; 0 to 1000  $\mu\text{V}$   $\Delta^*$ .

**Transfer accuracy:** (after 30 min. warmup) 2 ppm between saturated standard cells or unsaturated standard cells; 10 ppm standard cell to 1 V; 10 ppm saturated standard cell to unsaturated standard cells (typically better than 5 ppm).

**Stability:** (After 30 min. warmup) Better than 10 ppm/month.

**Line regulation:**  $< 1 \mu\text{V}$  for  $10^\circ/\text{line change}$ .

**Output impedance:**  $1 \text{ k}\Omega \pm 1\%$ .

**Short-circuit current:**  $< 1.5 \text{ mA}$ .

**Temperature coefficient:**  $< 1 \text{ ppm}/^\circ\text{C}$ ,  $0^\circ$  to  $+50^\circ\text{C}$ .

#### Variable output:

**Range:** 0 to 1000  $\mu\text{V}$ .

**Accuracy:**  $0.1\% \pm 1.5 \mu\text{V}$ .

**Resolution:**  $1 \mu\text{V}$ .

**Output impedance:**  $146\Omega \pm 1\%$ .

**Output noise:** dc to 1 Hz  $< 1 \mu\text{V p-p}$ .

1 Hz to 1 MHz:  $< 100 \mu\text{V rms}$ .

**Output:** Floating and guarded.

**Power:** 115 or 230 V  $\pm 10\%$ , 50 to 1000 Hz, approximately 12 W.

**Output terminals:** Four 5-way binding posts. Positive, negative, circuit-guard shield, and chassis ground; positive and negative terminals are solid copper with gold flash. A maximum of 500 Vdc may be connected between chassis ground and guard or circuit ground.

**Dimensions:** Standard  $\frac{1}{3}$  module.  $5\frac{1}{8}$ " wide, 3" high, 11" deep (130, 2 x 76, 2 x 279, 4 mm).

**Weight:** net:  $5\frac{1}{2}$  lbs (2.5 kg); shipping: 8 lbs (3.6 kg).

**Price:** HP 735A dc Transfer Standard, \$375.



## DC STANDARD & NULL METER

0 - 1000 volts with 0.002% accuracy  
Model 740B



### Description

#### DC Standard

The 740B is an ultra-stable, high-resolution dc standard source which delivers output voltage from 0 to 1000 V with a specified accuracy of  $\pm(0.002\%$  of setting + 0.0004% of range). Designed for calibrating digital voltmeters, differential voltmeters, potentiometers, voltage dividers and for general applications, the 740B has six-digit resolution with discrete steps of 1 ppm at full scale.

The 740B will deliver current up to 50 mA and may be set at any desired level between 5 mA and 50 mA by a continuously adjustable front-panel control. A front-panel indicator displays overload conditions as the load current exceeds the current limit setting. Low output impedance is maintained by remote-sensing terminals which control the output voltage at the load. The entire circuit is floating and guarded.

The stability of the 740B is dependent primarily on the stability of the reference source and the stability of the precision wire-wound resistors which comprise the decade and range dividers. The heart of the reference voltage supply is a temperature-compensated Zener diode which, with other critical components, is housed in a proportionally controlled oven. The entire reference supply is pre-aged from 4 to 6 weeks before being placed in the instrument. The stability of the reference voltage is recorded during this time and printed on a chart supplied with the instrument.

#### Precision dc amplifier

The instrument can be used as a dc power amplifier, in differential voltmeter or voltmeter modes by connecting the source to the input terminals and taking the output from the terminals that normally supply the standard calibrated voltages.

#### Bonus

The 740B, in addition to the dc standard, may be used as a precision dc differential voltmeter and a high Z dc voltmeter. For additional information refer to the voltmeter section of this catalog, page 212.

### Specifications

#### DC Standard

##### Ranges

**Output voltage:** 0 to 1000 V\* in 4 decade ranges with output as follows:

- 0 to 1.000000 V in 1  $\mu$ V steps
- 0 to 10.00000 V in 10  $\mu$ V steps
- 0 to 100.0000 V in 100  $\mu$ V steps
- 0 to 1000.000 V in 1 mV steps

##### Performance rating

**Accuracy:**  $\pm(0.002\%$  of setting + 0.0004% of range) at 23°C  $\pm 1^\circ$ C less than 70% relative humidity, constant load.

**Stability:** rated accuracy is met after 1 hour warm-up period, with a 30-day calibration cycle.

**Short term:** 1 ppm of setting + 0.5 ppm of range/hour; 5 ppm of setting + 1 ppm of range/day. (<100 V output.)

**Temperature coefficient:** <(2 ppm of setting or 1 ppm of range, whichever is greater) per  $^\circ$ C, 10°C to 40°C.

##### Output characteristics

**Output current:** current limiter continuously adjustable 5-50 mA nominal. Max. output current, 50 mA decreasing linearly to 20 mA at 1000 V output.

**Output resistance:** <(0.0002 + 0.0001 Eo)  $\Omega$  at dc.

**Load regulation:** <(0.0005% + 10  $\mu$ V) change, no load to full load.

**Line regulation:** <  $\pm(0.0005\%$  of setting + 0.0001% of range) for 10% line voltage change.

**Noise and hum:** .01 to 1 Hz: <1 ppm of range 1 Hz to 1 MHz: 100 dB below full scale or 100  $\mu$ V rms, whichever is greater.

**Output terminals:** plus and minus output, plus and minus sense, circuit guard, and chassis ground. Banana jacks mounted on remote terminal box (Accessory 11055B, furnished). Output and sense terminals are solid copper, gold-flashed. A maximum of 500 V dc may be applied between chassis ground and guard or circuit ground.

\*A maximum of 500 V dc with respect to line ground can be applied to or obtained from the HP 740B.

**Zero control limits:**  $\pm 0.001\%$  of range nominal.

**Readout:** 5 digital display tubes indicate first 5 digits; meter displays position of the 6th voltage set switch.

#### Amplifier

**Voltage gain:** recorder output; 120 dB maximum.

**Output terminals:** 60 dB on 1 mV range; 40 dB on 10 mV range; 20 dB on 100 mV range; unity on 1 V to 1000 V ranges.

#### Performance rating (output terminals):

**Gain accuracy:**  $\pm (0.01\%$  of reading  $+ 5$  ppm of range  $+ 2 \mu\text{V})$  referred to input.

**Linearity:**  $\pm 0.002\%$  on any range.

**Output current:** same as dc standard.

**Bandwidth:** dc to 0.2 Hz.

**Input resistance:**  $>10^{10}$  ohms, 100 mV to 1000 V ranges;  $>10^9$  ohms on 10 mV range;  $>10^8$  ohms on 1 mV range, independent of null condition.

**Line regulation:**  $<0.0005\%$   $+ 2 \mu\text{V}$  referred to input for 10% line voltage change.

**Noise:** 0.01 Hz to 1 Hz (referred to input)  $<0.5 \mu\text{V}$  p-p at 60 dB;  $<1.0 \mu\text{V}$  p-p at 40 dB gain;  $<3 \mu\text{V}$  p-p at 20 dB gain. Unity gain (1 V range and above) same as dc standard. 1 Hz to 1 MHz; 1 V to 1000 V ranges, same as dc standard; below 1 V range,  $<100 \mu\text{V}$  rms.

#### General

**Operating temperature:**  $+10^\circ\text{C}$  to  $+40^\circ\text{C}$ .

**Storage temperature:**  $-40^\circ\text{C}$  to  $+65^\circ\text{C}$ .

**Power supply:** 115/230 V ac  $\pm 10\%$ , 50 Hz to 1000 Hz, 125 W max.

**Dimensions:** 7" high,  $16\frac{3}{4}$ " wide,  $18\frac{3}{4}$ " deep (118 x 425 x 476 mm). Rack mount kit (5060-0776) furnished with instrument.

**Weight:** net 47 lbs (21,3 kg); shipping 65 lbs (29,5 kg).

#### Accessories furnished:

**11054A Input Cable for 740B:** 4 banana jacks mounted on terminal box with 3-foot cable and mating connector. Terminals include positive and negative input, circuit guard, and chassis ground. Positive and negative terminals are solid copper, gold-flashed. A switch allows reduction of input resistance to 2 M $\Omega$ .

**11055B Output Cable for 740B:** 6 banana jacks mounted on terminal box with 3-ft. cable and mating connector. Terminals include positive and negative output, positive and negative sense, circuit guard, and chassis ground. Output and sense terminals are solid copper, gold-flashed.

**Price:** HP 740B, \$2350.

## PORTABLE DC NULL VOLTMETER

18 ranges, 0.1  $\mu\text{V}$  resolution

Model 419A

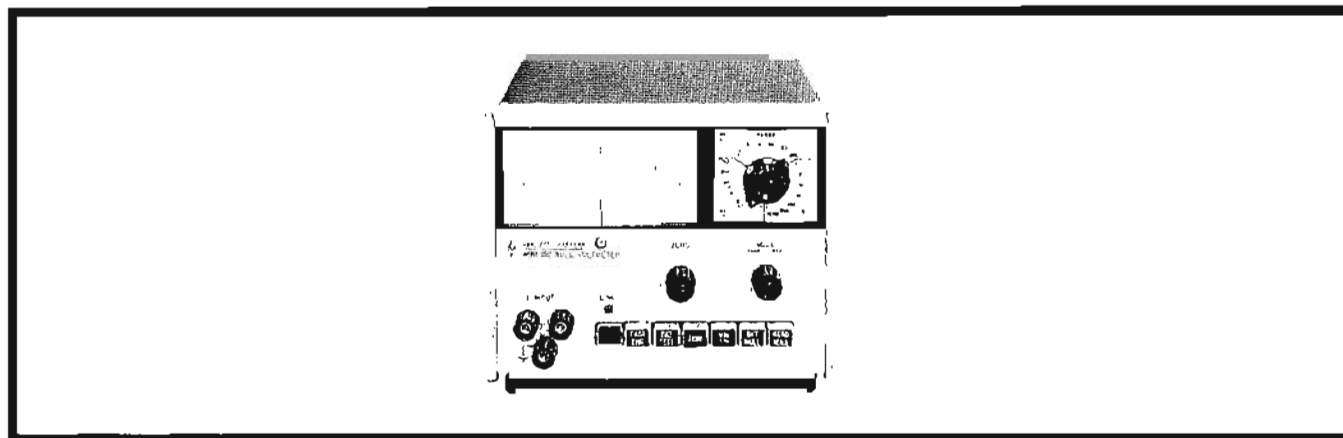

#### Description

The Model 419A DC Null Meter is a solid-state, battery operated micro-voltmeter with 0.1  $\mu\text{V}$  resolution.

The 419A is an excellent dc null detector for comparing a standard voltage with another source voltage, resistive divider or amplifier. By connecting the two voltages to the + and - floating input terminals, the voltages oppose each other and the instrument under test may be adjusted to the exact dc voltage of the standard instrument. This is accomplished by nulling the difference between the two sources on the 419A's 3  $\mu\text{V}$  range with a resolution of 0.1  $\mu\text{V}$ . Internal noise is very low, even at this resolution.

The 419A is operated from a rechargeable battery-power source so that it can be isolated from the ac power line, eliminating ground loops.

The 419A offers a feature not available in any other dc null meter... an adjustable internal nulling supply. An infinite input impedance is obtained (even on the 3  $\mu\text{V}$

range) when used as a null detector with the internal nulling supply.

#### Additional applications

(1) The 419A, because of its high-input impedance and sensitivity, may be used for measurements where a voltage must be read, compared or adjusted across a resistor.

(2) Collector voltages may be measured in transistor circuits.

(3) Voltages may be measured across a resistive divider.

(4) Because of its high sensitivity, the 419A may be used to measure thermocouple voltages and other low-level transducer sources.

(5) Nerve potentials in biology and medicine, as well as chemically-generated emf may be measured.

For complete specifications, see page 186-187.



## DC STANDARD

So many tasks so well at so great a value  
Model 741B

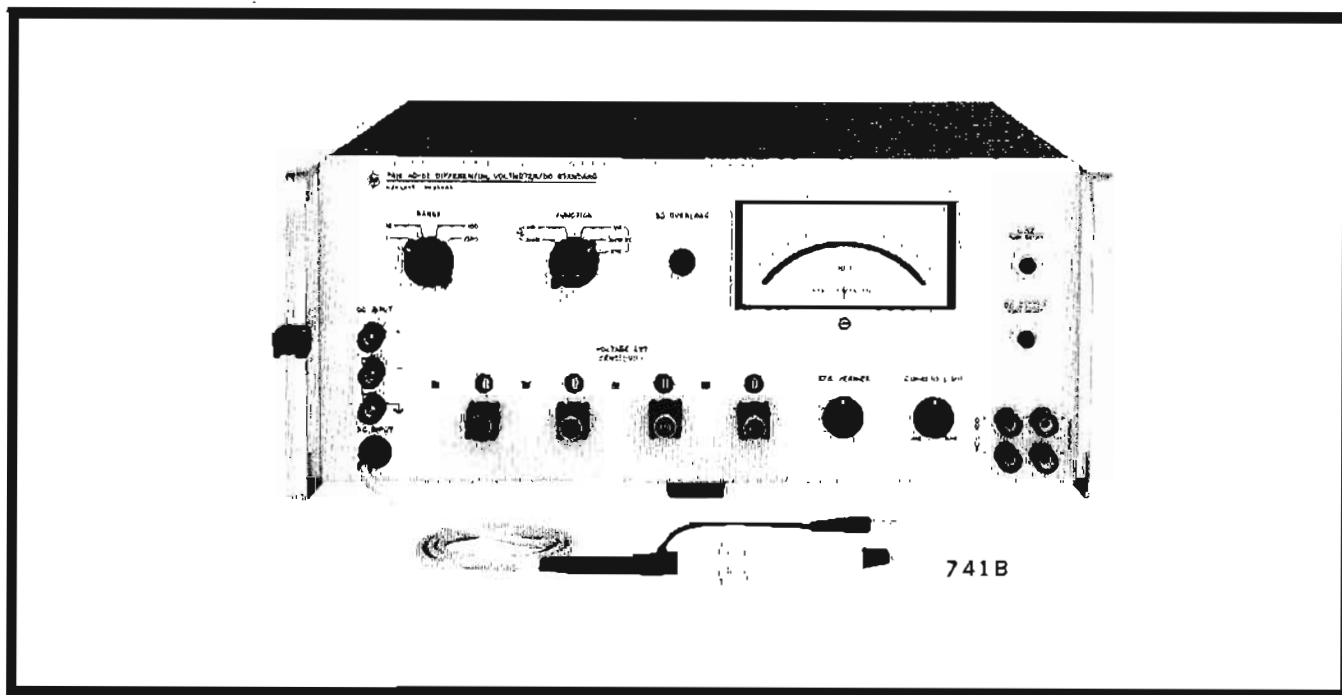

## Uses:

- High voltage dc standard source
- Measure power supply stability
- Calibrate precision voltmeters
- DC standard transfer measurements
- Measure accurately dc resistive dividers

## Features:

- DC standard  $\pm 0.01\%$  accuracy
- AC  $\Delta VM \pm 0.03\%$  accuracy
- DC  $\Delta VM \pm 0.02\%$  accuracy

The 741B is an ultra-stable, high-resolution dc standard source which delivers output voltage from 0 to 1000 volts with a specified accuracy of  $\pm 0.01\%$  of setting or  $0.001\%$  of range, whichever is greater. Used as a dc standard, the 741B provides adjustable dc voltages with 6-digit resolution, simplifying the calibration of digital voltmeters, differential voltmeters, potentiometers, and voltage dividers. Designed for general lab applications, the 741B has 1 ppm output voltage resolution on any full scale range.

The 741B will deliver current up to 20 mA and may be current-limited between 4 mA and 20 mA by a continuously adjustable front-panel control. A front-panel indicator displays overload conditions as the load current exceeds the current-limit setting. The output terminals allow the instrument to be used as a floating or grounded two-terminal device or a four-terminal output with remote sensing.

## Stability

The stability of the 741B is dependent primarily on the stability of the reference source and the precision, wire-wound resistors which comprise the decade and range dividers. The heart of the reference voltage supply is a temperature-compensated Zener diode which, with other critical components, is housed in a proportionally controlled oven.

Typical 741B stability is demonstrated in Figure 1 which shows a 741B opposed by a band of 9 standard cells. The overall 24-hour stability is better than 1 ppm. The  $0.01\%$  accuracy of the 741B is maintained after a 1-hour warmup for 90 days without calibration.

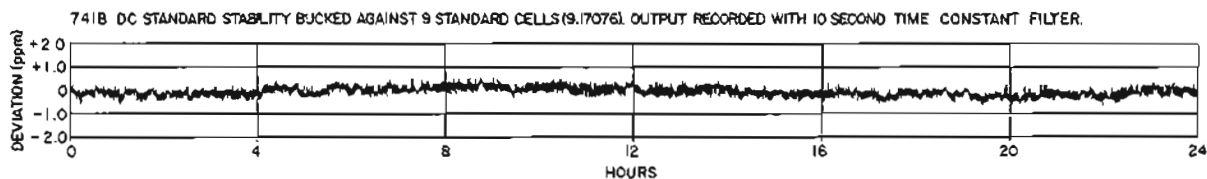

Figure 1. Total overall stability of the 741B is better than 1 ppm for a 24-hour period.

### Power amplifier

As a  $\pm 0.02\%$  power amplifier, the HP 741B provides unity voltage gain from 0 to 1000 volts. Stability is better than 0.001%/day, and an output up to 20 mA (20 W max.) is available.

### Voltage amplifier

A voltage amplifier up to 60 dB gain is available at the recorder terminals (voltage output is directly proportional to meter deflection). Maximum output is 1 V dc nominal into 1 k ohm load.

### High-impedance ac or dc voltmeter

The Model 741B is a  $\pm 2\%$  floating dc voltmeter with ranges from 1 mV to 1000 V. It is also a  $\pm 2\%$  floating ac voltmeter from 50 mV to 1000 V with reduced accuracy to 1 mV. Input impedance (dc) is greater than  $10^9$  ohms on all ranges. The low-capacity probe provides a high-input

impedance (1 megohm shunted by  $< 5$  pF) on all ranges in ac operation.

### AC or dc differential voltmeter

As an ac differential voltmeter, the 741B measures ac voltages from 1 mV to 1000 V and as a dc differential voltmeter it measures dc voltages from 0 to 1000 V. For further information, refer to the differential voltmeter section, page 213.

### Option

The 741B Option 01 offers  $\pm 0.01\%$  accuracy in dc differential voltmeter mode of operation and  $\pm 0.02\%$  accuracy in dc standard operation. All other specifications in the 741B Option 01 are identical to the standard 741B. The standard 741B or 741B Option 01 can be calibrated by the user to operate as a  $\pm 0.01\%$  dc standard or dc differential voltmeter by making one simple adjustment.

## Specifications

### DC Standard

**Output voltage ranges:** 0 to 1000 V\* in 4 decade ranges with outputs as follows: 0 to 1 V with 1  $\mu$ V resolution; 0 to 10 V with 10  $\mu$ V resolution; 0 to 100 V with 100  $\mu$ V resolution; 0 to 1000 V with 1 mV resolution.

### Performance rating

**Accuracy\*\*:**  $\pm 0.01\%$  of indicated setting or  $\pm 0.001\%$  of range, whichever is greater. Relative humidity  $< 80\%$ .

**Stability:** rated accuracy is met after 1-hour warmup period, with a 90-day calibration cycle.

**Short-term stability:** 10 ppm of setting + 1 ppm of range for a 24-hour period.

### Output characteristics

**Output current:** 0 to 20 mA, output current limiter continuously variable from 4 to 20 mA (nominal) 0 to  $+40^\circ\text{C}$ . Reduced to 10 W maximum from  $+40^\circ\text{C}$  to  $+50^\circ\text{C}$ .

**Output resistance:**  $< (0.0005 + 0.0005 E_o) \Omega$  at dc.

**Load regulation:**  $< 10$  ppm + 10  $\mu$ V no load to full load.

**Line regulation:**  $< \pm (10$  ppm + 10  $\mu$ V) for  $\pm 10\%$  line-voltage change.

**Remote sensing:** permits output regulation at the point of application.

**Temperature coefficient:**  $< 3$  ppm/ $^\circ\text{C}$  from  $0^\circ\text{C}$  to  $+50^\circ\text{C}$ .

**Noise and hum:** dc to 1 Hz, 100 dB below full scale; 1 Hz to 1 MHz,  $-100$  dB below full scale or 200  $\mu$ V, whichever is greater.

**Output:** floating (up to 500 V).

**Readout:** 4 digits plus individually calibrated raut-band meter.

### Power Amplifier

**Accuracy:**  $\pm 0.02\%$  of rdg or  $\pm 0.002\%$  of rge, whichever is greater.

**Output current:** same as dc standard.

**Voltage gain:** unity 0 to 1 kV.

**Stability:** better than 0.001%/day after 1-hour warmup.

**Bandwidth:** dc to 0.1 Hz.

**Line and load regulation:** same as dc standard.

**Input impedance:**  $> 10^9$  ohms on all ranges.

**Superimposed ac noise rejection:**  $< 0.01\%$  error (above 50 Hz) for ac rms voltage equal to 50% of input dc or 25 V rms, whichever is less.

**Noise:** same as dc standard.

### High-Impedance AC Voltmeter

#### Accuracy:

Accuracy (end scale)	50 mV — 1 kV	1 mV — 50 mV
2%	20 Hz — 100 kHz	
2% $\pm 200 \mu$ V		20 Hz — 50 kHz

**Input voltage ranges:** 1 mV to 1000 V ac end scale.

**Input impedance:** 1 M $\Omega$  shunted by  $< 5$  pF.

### High-Impedance DC Voltmeter

**Input voltage ranges:** 1 mV to 1000 V\* end scale (1 mV to 100 mV range obtained by using null sensitivity push-buttons).

**Accuracy:**  $\pm 2\%$  of range.

**Input impedance:**  $> 10^9$  ohms, all ranges.

**Superimposed ac noise rejection:** same as power amplifier.

### General

**Recorder output:** available for all modes of operation.

**Recorder amplifier:** recorder voltage output directly proportional to meter deflection, 60 dB gain (max), 1 mA into 1 k load.

**Power supply:** 115 or 230 V  $\pm 10\%$ , 50 Hz to 1000 Hz, 125 W max.

**Dimensions:** 7" high, 16 $\frac{3}{4}$ " wide, 18 $\frac{1}{4}$ " deep (178 x 425 x 464 mm).

**Weight:** net 47 lbs (21 kg); shipping 65 lbs (29.5 kg).

**Price:** HP 741B, \$1675.

**Option 01:** \$1675.

\*A maximum of 500 V dc with respect to line ground can be applied to or obtained from the HP 741B.

\*\*741B Option 01 provides  $\pm 0.02\%$  dc standard accuracy and  $\pm 0.01\%$  dc differential voltmeter accuracy.



## AC/DC METER CALIBRATOR

Four calibrators in one case

Model 6920B

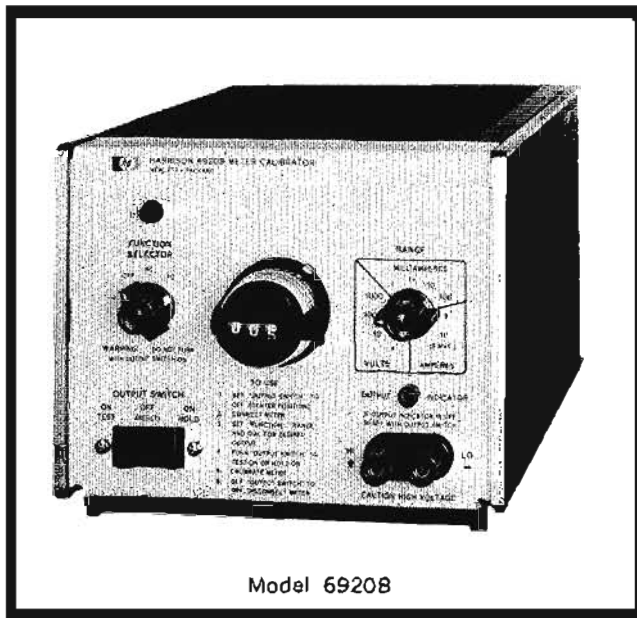

Model 6920B

### Can be used to check:

1. DC Voltmeters up to 1000 volts
2. AC Voltmeters up to 1000 volts
3. DC Ammeters up to 5 amps
4. AC Ammeters up to 5 amps

### Description

Model 6920B is a versatile ac/dc meter calibrator, capable of both constant voltage and constant current output. Its absolute accuracy makes it suitable for laboratory or production testing of panel meters, multimeters, and other meters having accuracy of the order of 1.0% or higher. This calibrator has been designed for convenience, and combines in one instrument all the outputs needed to test the more commonly used meters. Model 6920B has been packaged in an HP cabinet module suitable for bench or rack use. For more information on mounting accessories, see pages 568 and 569.

### Output switch

An output switch selects the safest mode of operation for the particular type of meter being tested. A "lock" position leaves the testing parameters in operation to free both hands for attaching and disconnecting successive meters. A "test" position, springloaded so that the meter calibrator output is presented to the terminals only while finger pressure is applied, facilitates testing meters with several full-scale values and reduces the danger of burn-out.

### AC Output waveshape

When the function switch is set on "AC", the output waveshape is sinusoidal (to a first approximation) and has the same frequency as the input line power applied to the instrument. The feedback loop which controls and regulates this AC is actually monitoring the average value of the ac output, although the front panel controls are calibrated in terms of rms. Thus this calibrator is suitable for use with average reading ac voltmeters scaled in rms. Moreover, it is

not improper to use this calibrator with true rms meters provided the input line waveshape has a negligible amount of harmonic distortion. The meter calibrator's contribution to the total harmonic distortion present in its output is small compared to its overall accuracy.

### Specifications

**Input:** 105-125 V ac, single phase, 58-62 Hz, 0.7 amp., 65 watts max.

#### Output voltage ranges:

- |           |                             |
|-----------|-----------------------------|
| 0.01-1 V  | current capability 0-5 A    |
| 0.1-10 V  | current capability 0-1 A    |
| 1-100 V   | current capability 0-100 mA |
| 10-1000 V | current capability 0-10 mA  |

Above output voltage ranges and maximum current capabilities for each range apply in full for either dc or 60 Hz, operation.

#### Output current ranges: (5 amp. maximum output)

- |               |                            |
|---------------|----------------------------|
| 1-100 $\mu$ A | voltage capability 0-500 V |
| 0.01-1 mA     | voltage capability 0-500 V |
| 0.1-10 mA     | voltage capability 0-500 V |
| 1-100 mA      | voltage capability 0-50 V  |
| 0.01-1 A      | voltage capability 0-5 V   |
| 0.1-10 A      | voltage capability 0-0.5 V |

Above output current ranges and maximum voltage capabilities for each range apply in full for either dc or 60 Hz, operation.

**Output accuracy:** DC—0.2% of set value plus 1 digit. AC—0.4% of set value plus 1 digit. Above accuracy applicable over a temperature range from 15°C to 35°C and over full input voltage range.

#### Controls:

**FUNCTION SWITCH**—This is a 3-position switch: "OFF", "AC", and "DC". In the "OFF" position the ac power input is disconnected from the unit. In the "AC" position the meter calibrator produces an ac output; similarly, in the "DC" position the calibrator produces a dc output.

**RANGE SWITCH**—10 positions, one for each voltage and current range.

**CALIBRATED OUTPUT CONTROL**—Digital potentiometer readout control (3 significant digits) determines exact value of output.

**OUTPUT SWITCH**—Switch described above.

**Output terminals:** two front panel terminals are provided; these are the output terminals for both ac and dc operation. In voltage ranges, the negative terminal is grounded. In current ranges, both terminals must be disconnected from any shunting paths to ground.

**Ripple:** in dc operation the output ripple is typically less than 1.0% rms of the output range switch setting.

**Operating temperature range:** 0-50°C.

**Size:** 6 $\frac{3}{4}$ " (172 mm) H x 7-13/16" (198 mm) W x 11" (279 mm) D.

**Weight:** 15 lbs (6.8 kg) net, 17 lbs (7.71 kg) shipping.

**Price:** \$695.00.

**Option 05:** 50 Hz ac input regulation realignment, add \$25.

**Option 28:** Rewire for 230V single phase ac input, add \$10.



# VOLTMETER CALIBRATOR

DC, rms and p-p volts; flatness 10 Hz-10 MHz  
Model E02-738BR



## WORKING STANDARDS

### Description

The 652A Test Oscillator and the 738BR Voltmeter Calibrator calibrates high-impedance voltmeters and oscilloscopes for both frequency response and voltage accuracy. The system combines two moderately priced basic Hewlett-Packard instruments that calibrate for ac and dc voltage levels from 300  $\mu$ V to 300 V in precise preselected steps and calibrate for frequency response from 10 Hz to 10 MHz.

The two instruments are available individually or in a single enclosure provided with a rear-access door and power strip as the E02-738BR.

The 738BR is a highly stable precision voltage source with drift less than 0.1% per week for dc voltage, less than 0.2%/° per week for ac voltage. The 652A provides a convenient constant-amplitude ac output voltage at an adjustable frequency from 10 Hz to 10 MHz. The instrument's expanded meter scale monitors the frequency response rapidly and accurately with  $\pm 0.25\%$  flatness.

### Specifications

#### E02-738BR Voltmeter Calibration System

##### 738BR

**Voltage range:** 300  $\mu$ V to 300 V, dc or ac (rms and p-p, 400 Hz).

**Levels:** calibration voltage 300  $\mu$ V to 300 V in steps of 1, 3, 1.5 and 5; tracking voltages 0.1 to 1 V in 0.1 V steps and 0.05 to 0.5 V in 0.05 V steps.

**Accuracy:** 300 V working voltage into attenuator, accurate within 0.1% dc and 0.2% ac, after a 30-minute warmup.

**Attenuator accuracy:** within  $\pm 0.1\%$  or  $\pm 2.5 \mu$ V, whichever is larger, open circuit.

**Long-term stability:** less than 0.1% dc drift per week, less than 0.2% ac drift per week.

### Thermal Converters

#### Models 11049A, 11050A, 11051A

Hewlett-Packard Thermal Converters are true rms indicators, yielding a dc output voltage proportional to the temperature rise resulting from the input power. The Models 11049A, 11050A and 11051A offer an exceptionally flat response and nearly constant impedance over a wide frequency range. These characteristics make the thermal converters ideal to check the response of precision ac voltmeters, oscilloscopes and amplifiers.

### Specifications

#### 11049A, 11050A, 11051A

##### Maximum input voltage:

11049A: 3 V rms; 11050A: 1 V rms; 11051A: 0.45 V rms.

**Input impedance:** 50 ohms  $\pm 0.15$  ohms to 10 MHz.

**Output voltage for maximum input voltage:** 7.5 mV dc (nominal).

**Dimensions:** 3" wide, 1 $\frac{1}{4}$ " high, 1 $\frac{1}{2}$ " deep (7,6 x 4,4 x 3,8 cm).

**Weight:** net 2.2 oz (62 g); shipping 1 lb (450 g).

**Price:** HP Model 11049A\*, \$125; HP Model 11050A\*, \$125; HP 11051A\*, \$125.

**Option 01\*:** calibration to 60 MHz, add \$25.

**Option 02\*:** calibration to 100 MHz, add \$50.

\*Includes individual calibration report with statement of uncertainty traceable to NBS.

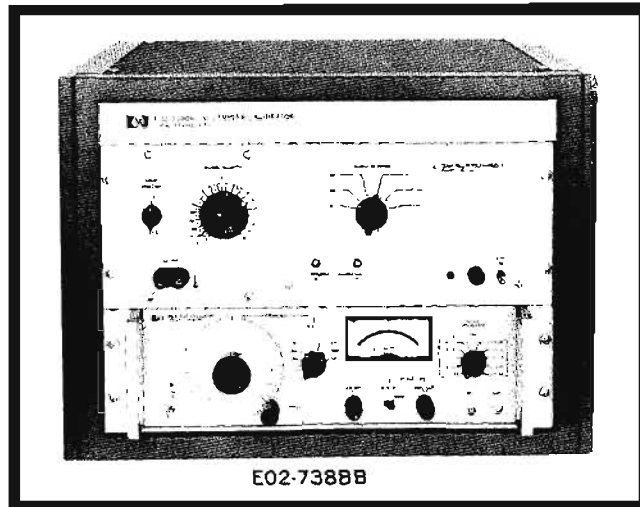

E02-738BR

**Power:** 115 or 230 V  $\pm 10\%$  50 to 60 Hz, 350 watts.

**Dimensions:** 19" wide, 7" high, 1 $\frac{3}{4}$ " deep behind panel (483 x 178 x 400 mm).

**Weight:** net 38 lbs (7 kg); shipping 53 lbs (24 kg).

**Price:** HP 738BR, \$850 (rack mount).

##### 652A

Specifications are listed on page 329 of this catalog.

##### General

**Dimensions:** 22 $\frac{1}{4}$ " wide, 16 $\frac{1}{2}$ " high, 18 $\frac{1}{2}$ " deep (565,2 x 419,1 x 469,9 mm).

**Weight:** net 105 lbs (47,3 kg); shipping approx. 135 lbs (60,8 kg).

**Price:** HP E02-738BR, \$1860.

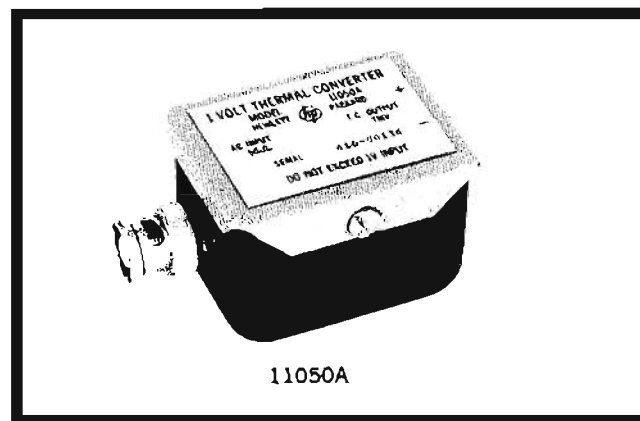

11050A

### Calibration accuracy

Frequency range	In reference to std.	Measurement uncertainty
20 Hz to 20 kHz	within $\pm 0.01\%$	$\pm 0.02\%$
20 kHz to 50 kHz	within $\pm 0.01\%$	$\pm 0.03\%$
50 kHz to 1 MHz	within $\pm 0.01\%$	$\pm 0.06\%$
5 Hz to 20 Hz and 1 MHz to 10 MHz	within $\pm 0.05\%$	$\pm 0.12\%$
10 MHz to 30 MHz		$\pm 0.25\%$
30 MHz to 60 MHz		$\pm 0.50\%$
60 MHz to 100 MHz		$\pm 1.50\%$



# Voltage, Current, Resistance



## ANALOG MEASURING EQUIPMENT

VOLTAGE, CURRENT,  
RESISTANCE

Voltage, current and resistance measurements are easy, fast and accurate with electronic instruments using meter movements. Most electronic voltmeters, ammeters and ohmmeters use rectifiers, amplifiers and other circuits to generate a current proportional to the quantity being measured, which then drives a meter movement. Devices of this type are called analog instruments.

**Meter Movements**—the meter-movement readout should continue to be popular since it is economical and suitable for many jobs. It also lends itself well to special, nonlinear scales such as dB scales.

The pivot-jewel suspension is being replaced more and more by the taut-band suspension. This has resulted in excellent repeatability with hysteresis virtually eliminated. This repeatability, in turn, makes practical the individually-calibrated meter scale. Both of these improvements, taut-band suspension and individually-calibrated scales, are standard in most HP analog voltmeters.

Figure 1 shows scales for two different meters printed by Hewlett-Packard's calibrator on one face. By combining an HP-produced, taut-band meter movement with custom calibration, outstanding ruggedness and precision are inherent in all meter movements which are produced, in volume, for Hewlett-Packard's electronic instruments.

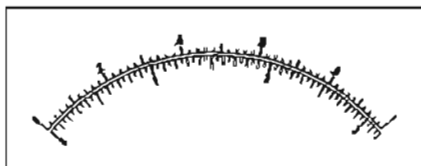

Figure 1. Scales for two different meters printed by Hewlett-Packard's calibrator on one face.

## DC voltage measurements

The dc voltmeter represents a straightforward application of electronics to measuring instruments. This instrument usually has a dc amplifier preceding the meter movement.

DC amplifiers can be classified as (a) direct-coupled types and (b) chopper types.

Direct-coupled amplifiers are attractive for their economy and find application in the lower cost electronic voltmeters. Figure 2 shows a direct-coupled amplifier used in the HP 427A.

The input signal is applied to a range attenuator and then to an impedance converter. A field-effect transistor Q1 is used as an impedance converter because of its high-input impedance. Transistors Q2 and

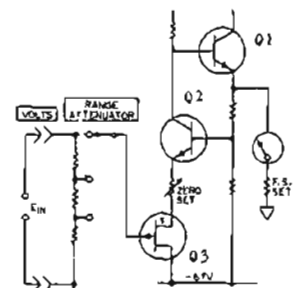

Figure 2. Basic dc voltmeter circuit.

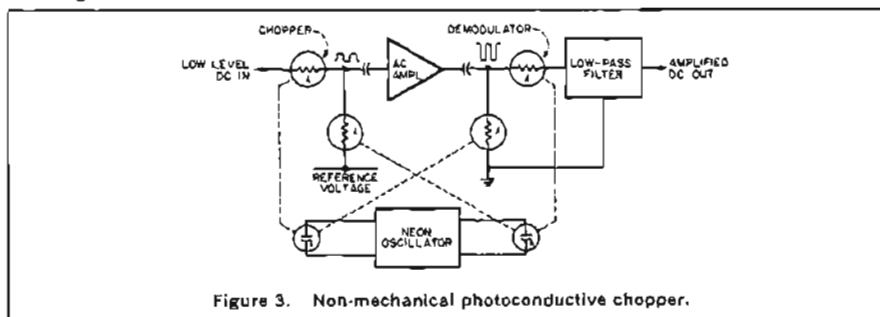

Figure 3. Non-mechanical photoconductive chopper.

Q3 make up a two-stage, direct-coupled amplifier which drives a meter. The amplifier is used to obtain sensitive ranges and higher input impedance than can be realized with non-electronic types of voltmeters. The input impedance of electronic types is frequently high enough that corrections for the loading effect of the voltmeter upon the circuit are not required.

An amplifier also limits the maximum current supplied to the meter movement, so that there is little danger that unexpected overloads will burn out the meter movement.

An extra bonus is a recorder output which delivers a dc voltage proportional to the meter indication. The voltmeter can thus be used as a narrow-band dc amplifier. In addition, other functions such as dc amperes and ohms may be provided.

Although most voltmeters are designed for line operation, battery operation is sometimes provided. Battery operation is useful for field operations or when isolation from the power line is required.

To supply ranges of a few millivolts or microvolts full scale, chopper amplifiers are generally used. Hewlett-Packard choppers can convert the input dc to a proportional ac with zero offsets of 1  $\mu$ V or less. The ac signal is first amplified and then converted back to dc (demodulated).

Overall scale-factor accuracy is assured by substantial dc feedback from the output back to the modulator. This feedback

also develops a high dc input resistance which, for the amplifier itself, often reaches 100 megohms or more. The input resistance presented to the voltmeter terminals is determined by the input attenuator, which is necessary for different input voltage levels.

The Hewlett-Packard Company has led for several years in the use of photoconductive choppers. A photoconductor (or photoresistor) has many megohms of re-

sistance when unilluminated, and a few hundred or thousand ohms when illuminated with a neon or incandescent bulb. The transition time between these two conditions (high and low resistance) at present limits the maximum chopping rate to a few hundred Hz. Usually, four photocells are mounted in one assembly with a simple neon oscillator. This supplies a demodulator as well as a series shunt, half-wave modulator. Figure 3 illustrates a typical chopper amplifier.

The HP 410C is representative of this class of instruments. Input impedance is typically 100 megohms, offering a negligible loading effect. The HP 410C uses a chopper-stabilized amplifier (CSA), which minimizes the drift characteristics of direct-coupled amplifiers.

The HP solid-state 419A DC Null Voltmeter also uses a CSA and has 0.1  $\mu$ V resolution, with 18 ranges from 3  $\mu$ V to 1000 V. An internal, adjustable bucking voltage allows the operator to null the input signal with a front-panel control, effectively making the input impedance infinite. This dc null voltmeter is powered by rechargeable batteries.

**AUTOMATIC FEATURES**—automatic polarity and range-selection features are available. The operator can detect polarity and measure any voltage within the range of the instrument without setting controls. The meter indication is automatically maintained between 1/3 and full scale, while the range also is automatically displayed. These features

are offered in the HP 414A Autovoltmeter. Outstanding accuracy can be obtained using this model. Figure 4 compares the HP 414A accuracy versus reading against other instruments with specified accuracy of 1% or 2% of full scale.

### DC current measurements

For most dc current measurements, the meter movement, by itself, serves the purpose admirably. In these cases, the meter coil requires relatively few turns to generate sufficient magnetic flux for deflecting the meter pointer. For lower current measurements, though, the sensitivity of the meter movement must be increased, usually by using more turns in the coil. These added turns increase the resistance of the current path, which can be troublesome in low-impedance circuits.

Electronic instruments overcome this difficulty by measuring the small voltage drop across a low-value resistance placed in series with the current to be measured.

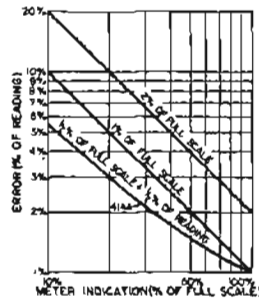

Figure 4. Accuracy vs. reading.

The HP 412A, 425A and 419A Voltmeters are equipped with internal-calibrated shunt resistors for reading dc currents without accessory equipment. These instruments cover the range from 10 pA to 1 A full scale (412A, 1  $\mu$ A to 1 A full scale; 425A, 10 pA to 3 mA full scale; 419A, 30 pA to 30 nA full scale; 410C, 1.5  $\mu$ A to 150 mA full scale).

Current measurements using a series resistor have the obvious disadvantage of interrupting the circuit under test. In many applications, insertion of a resistance in the line of current flow may alter the current being measured or even alter the circuit operation. To overcome this difficulty, the HP 428B Clip-On DC Milliammeter uses current probes which simply clip around the current-carrying wire and measure direct currents from 0.1 mA to 10 amperes without interrupting the circuit.

The HP 428B enables current measurements to be made as easily as voltage measurements, requiring no alteration of the circuit under test.

The clip-on probes are finding wide use in solid-state circuit measurements where current flow has to be monitored carefully. Sensitivity is such that even base current can be measured. There are a variety of other uses, such as measuring the current in ground loops where the im-

pedance is too low for the series-resistance technique to be applied.

The HP Model 3528A Current Probe allows current measurements in conductors up to 2½ inches in their maximum dimensions. Such conductors are not limited to wires, but can be pipes, multi-conductor cables, lead sheathed cables or microwave waveguides. With this large aperture probe, difficult-to-measure quantities like corrosion current in small structural members, circulating dc and low-frequency currents in ground straps and waveguides can easily be determined. Low-frequency current to 400 Hz is measured by connecting an oscilloscope or ac voltmeter to the HP 428B recorder output.

### Resistance measurements

Resistance is customarily determined through the familiar Ohm's relation:  $E=IR$ . By applying a known voltage,  $E$ , to the unknown resistance,  $R$ , and then measuring the current,  $I$ , passing through it,  $R$  can be computed.

A modified procedure for doing this with electronic voltmeters is shown in Figure 5. Here, the current flowing in the circuit depends on the series combination of the unknown resistor  $R_x$  and the internal resistor  $R_i$ . Both voltage and current in the external circuit will change according to the value of the unknown. To account for this, HP instruments, such as the HP 410B, 410C, 412A and 427A, have individually calibrated taut-band meter scales. If  $R_x$  were infinite, the meter would read the full battery voltage  $E_i$ . Full-scale deflection would therefore correspond to a resistance of infinity. If  $R_x$  were zero (short circuit), the meter would read zero. The mid-scale range then occurs when  $R_x$  equals  $R_i$ .

The resistance  $R_i$ , included as part of the ohmmeter, provides a convenient means of changing the range of the instrument. The HP 410C has mid-scale resistance readings ranging from 10 ohms to 10 megohms in seven ranges.

Using another method, the HP 414A employs a feedback-stabilized current source, allowing the use of a linear ohms scale and avoiding a special meter scale for resistance measurements. The resulting meter scales are easy to read with good resolution at lower-resistance values.

### AC voltage measurements

Electronic instruments for measuring ac voltages also use an amplifier with the meter movement. Analog ac voltmeters are ac-to-dc converters which derive a dc current proportional to the ac input being measured, employing this current for meter deflection. Conversion to dc eliminates the necessity of having the movement respond to the frequencies being measured. In some situations, conversion to dc by use of external probe diodes

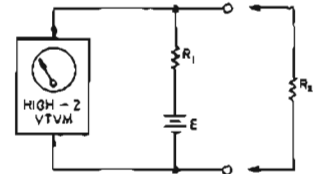

Figure 5. Resistance measurement with an electronic voltmeter.

precedes amplification (HP Models 410B, 410C and 411A). The required amplifiers must then be dc amplifiers, either direct-coupled or chopper type. In other cases (HP 400 Series Models), the dc may be derived as a final step with sufficient power available to directly drive the meter movement of the voltmeter. Finally, any ac amplifier may readily be a broadband dc amplifier preceded by an input-blocking capacitor. This is sometimes used when fast recovery from overload is desired. For further information on dc amplifiers, refer to Hewlett-Packard Application Note 69.

### AC voltmeters

Analog (meter) indicating ac voltmeters fall into three broad categories: average-responding, peak-responding, and rms-responding. AC voltmeters in general use are average and peak-responding types in spite of the fact that rms values are of principle interest. A choice among the three types should be made on the basis of cost and usefulness for a range of particular measurements.

#### Average-responding voltmeters

The widely used HP 400 series voltmeters are average-responding meters. The average value of an ac voltage is simply the average value of voltage measured point-by-point along the waveform. For a sine wave and any waveform symmetrical about zero, the true average value is zero. However, a resistive load is heated by both the positive and negative current excursions in proportion to the absolute average of voltage above and below zero. Accordingly, when we speak of average voltage, we mean the average value of a full-wave rectified voltage. This value for sine wave is 0.636 times the peak voltage.

For a sinusoidal waveform, then, the rms value can easily be calibrated on a meter that responds to the average value, since the rms value is greater by the constant  $k = 0.707/0.636 = 1.11$ . Many waveforms encountered in electronic measurements are sinusoidal; in these instances, the average-responding meter, calibrated in the rms value of a sine wave, provides an accurate indication of the rms value.

Average values of several other waveforms are known. For example, the average value of a symmetrical square wave is 1.0 times the maximum value; and the average value of a symmetrical triangle wave is 0.5 times the maximum value.

Average-responding voltmeters are much less expensive for the same accuracy and bandwidth than a true rms voltmeter for sinusoidal waveforms. Average-responding voltmeter error due to harmonic distortion is low—less than 3% for about 10% harmonic distortion. Refer to Hewlett-Packard Application Note #60, "Which AC Voltmeter," for additional information.

### Sampling voltmeters

Conventional voltmeters which respond to the absolute average or the true rms value of an ac waveform are commonly limited in sensitivity and bandwidth by the input impedance converter, amplifier and detector. These restrictions may be relieved by sampling the signal prior to amplification and detection. This technique constructs low-frequency equivalents of high-frequency signals and permits voltmeters to make measurements over wide frequency and voltage ranges. Sampling high-frequency waves in order to construct low-frequency equivalents of them is a powerful technique for measuring and observing broadband signals. The sampling oscilloscope, introduced by Hewlett-Packard a number of years ago, can display repetitive waveforms containing frequency components up to several GHz. A more recent development, the HP 3406A Sampling Voltmeter, responds to the absolute-average values of unknown voltages and is calibrated to read both the rms value of a sine wave and dBm in 50-ohm systems. It has eight voltage ranges from 1 mV to 3 V full scale, and its sensitivity is high enough to measure voltages as small as 50  $\mu$ V over a 25 kHz to >1 GHz frequency range. Voltage scales are linear, and resolution is 20  $\mu$ V on the 1 mV range. Unlike some RF voltmeters with peak detectors that are rms-responding on the lower ranges and gradually change to peak-detecting on the higher ranges, the HP 3406A is average-responding on all ranges. This means that measurements of non-sinusoidal voltages are more accurate because its detector law does not change with the amplitude of the input signal.

Instead of the coherent, waveform-preserving sampling method used in most sampling instruments, the 3406A uses an incoherent technique which does not preserve the input waveform. In this type of sampling, the input voltage is sampled at irregular intervals having no relationship to any of the frequency components of the input signal. Enough samples are taken, though, so that the average, peak, and rms values of the samples closely approximate the average, peak, and rms values of the input voltage. The information relevant to the voltage-measuring function is preserved; and waveform, not required in this technique, is not preserved.

Incoherent sampling is especially advantageous in a voltmeter because it gives the meter the sensitivity, accuracy and broad-frequency range of a sampling instrument; yet it is less costly than coherent techniques. Unlike coherent sampling, it neither requires a triggering source nor that the input signal be periodic. The sampling voltmeter operates equally well with sinusoidal, pulsed, random or frequency-modulated signals.

The sampling circuit of the HP 3406A Voltmeter is located in its probe which is ac-coupled and permanently attached to the instrument with a 3-foot cable. When pressed, a pushbutton located on the probe causes the voltmeter to retain its reading until the button is released. Figure 6 illustrates the block diagram of the HP 3406A.

A more recent development, the HP 8405A RF Vector Voltmeter, can measure amplitudes and phase angles simultaneously from 1 to 1000 MHz. The 8405A RF Vector Voltmeter operates on the principle of coherent sampling. For additional information, refer to page 240. Other sampling instruments are being investigated at HP for frequency ranges as high as X band (12.4 GHz).

### Peak-responding voltmeter

Like the average-responding voltmeter, the peak-responding type can be calibrated to read the rms value of a sinusoidal waveform. It is important to remember that the instrument indication is proportional to the peak above or below the average of the impressed waveform. The peak-responding voltmeter shown in Figure 7 places the rectifier in the input circuit where it charges the small input capacitor to the peak value of the input signal. This voltage is passed to a dc amplifier, which drives the meter.

In the peak-responding meter, ac to dc conversion is usually accomplished at the input, making a broadband meter and amplifier unnecessary. Consequently, it can be used to higher frequencies than the average-responding type; and it has a low shunt capacitance to minimize circuit loading. Since a dc meter circuit is required, many times dc volt, ohm, and ampere scales are added (as on the HP 410C) to make the peak-responding meter a multifunction instrument.

The extension of this technique into the ac millivolt range is impractical due to the nonlinear response of diodes at low-signal levels.

Both of these meters (average-responding and peak-responding) have scales calibrated to indicate the rms value of a sine-wave input voltage, since the meters are used primarily for sine-wave measurements. The average-responding type, therefore, reads 1.11 times higher than the average voltage; while the peak-responding type indicates 0.707 of the peak volt-

age. As a result, both meters may be in error if the measured signal is not a pure sine wave. The amplitude and phase of the harmonics present affect the peak and average values of the waveform, upsetting the rms calibration. The average-reading voltmeter is not affected by distortion as much as the peak-reading type. However, if highly complex waveforms are to be measured, a true rms-responding voltmeter is recommended. Write or ask for HP Application Note #60 for additional information concerning measurement error from harmonics or other spurious voltages.

### RMS-responding voltmeter

As mentioned previously, complex waveforms are measured most accurately by an rms-responding voltmeter. It is essential to remember that the instrument indication is proportional to the rms deviation about the average of the impressed waveform. Mathematically, the root-mean-square (rms) value of any complex quantity is obtained by summing the squares of each component and taking the square root of this sum, defined as the equivalent heating power of the waveform.

This operation is performed by sensing the waveform's heating power, which is proportional to  $(E_{rms})^2$ . The indicating circuitry responds to the square root of the heating power. Heating power is measured by feeding an amplified version of an input waveform to the heater of a thermocouple, the voltage output of which is proportional to the waveform's heating power.

Previously, the primary difficulty with that technique has been the nonlinear behavior of the thermocouple, slow response and burnout, complicating the calibration of the indicating meter. The new HP 3400A True RMS Voltmeter overcomes this difficulty with the use of two thermocouples mounted in the same thermal environment. Nonlinear effects in the measuring thermocouple are cancelled by similar nonlinear operations of the second thermocouple.

As shown in the block diagram of Figure 8, the amplified input signal is applied to the measuring thermocouple; and a dc feedback voltage is fed to the balancing thermocouple. The dc voltage is derived from the voltage output difference between the thermocouples. The circuitry may be looked upon as a feedback control system which matches the heating power of the dc feedback voltage to the input waveform's heating power. Meter deflection is proportional to the dc feedback voltage, directly proportional to the rms of the input signal. The meter indication, therefore, is linear.

This arrangement allows the Model 3400A to provide highly accurate readings of the rms value of complex waveforms

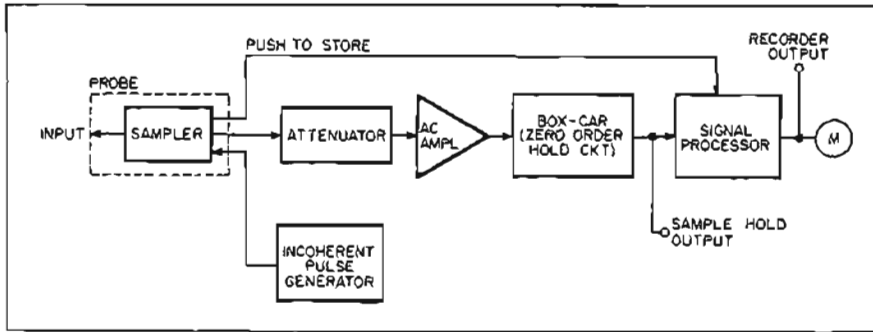

Figure 6. Block diagram of HP 3406A.

having crest factors (ratio of peak-to-rms) as high as 10:1. At 10% of full-scale deflection, where there is less likelihood of amplifier saturation, waveforms with crest factors as high as 100:1 are accommodated.

The 3400A reads voltages throughout a range of 100  $\mu$ V to 300 V rms within a frequency range of 10 Hz to 10 MHz.

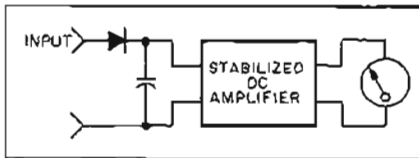

Figure 7. Peak-responding voltmeter.

### Voltmeter considerations

The most appropriate instrument for ac or dc voltage measurement is the instrument reliably giving the performance needed for the existing conditions. Some considerations are:

**CIRCUIT LOADING**—the voltmeter should have a considerably higher impedance than the test circuit. For example, measuring the low-frequency voltage across a 100 kilohm resistor with the voltmeter having a 10 megohm input resistance will result in an error of 1% because the voltmeter will change the test circuit. Input impedance is usually specified by its resistive and capacitive parts. The input reactance due to the input shunt capacitance  $C_{in}$  is a reciprocal function of frequency; therefore, the smaller  $C_{in}$  is, the smaller the loading error at higher frequency. In some applications, a passive voltage divider probe can be used to reduce the input capacitance at the point of measurement (at the sacrifice of about 20 dB of sensitivity). With such a probe, measurements can be made quite easily at random points without upsetting the circuit under test.

**RANGES**—the ranges on the meter scale may be in the 1-3-10 sequence with 10 dB of separation, 1.5-5-15 sequence, or with a single scale calibrated in decibels with 20 dB range steps. In any case, the scale divisions should be compatible with the accuracy of the instrument. A linear meter with 1% full-scale accuracy should have 100 divisions on the 1.0 scale so that 1% can be readily resolved. An instru-

ment with an error of 1% or less should have a mirror-backed scale to reduce the parallax problem.

**OUTPUTS**—some voltmeters provide several analog outputs besides the meter reading. For instance, there may be both ac and dc output proportional to the pointer deflection. The ac output is useful for monitoring the waveform on an oscilloscope or to lower the output impedance of the circuit under test. The dc output can be used to drive a strip chart or x-y recorder for a permanent record, or to

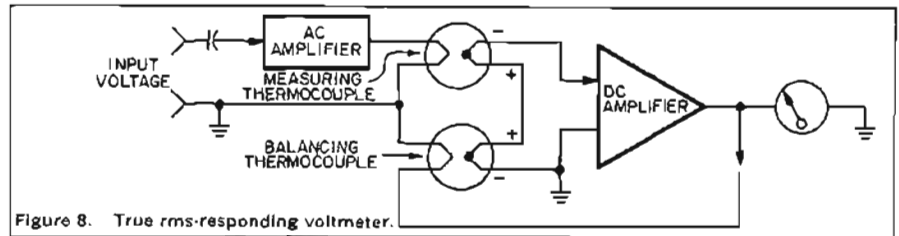

Figure 8. True rms-responding voltmeter.

drive a dc digital voltmeter to increase accuracy and resolution of broadband instruments.

**DECIBELS**—the decibel unit is very effective in measurements covering a wide range of voltages. The response of amplifiers and filters, for example, is usually expressed as a graph of voltage in decibels versus frequency. Most voltmeters with decibel scales are calibrated in dBm, referenced to some particular impedance. The 0 dBm reference for a 600-ohm system is 0.7746 V, and for a 50-ohm system is 0.2236 V. In many applications, only a 0 dB reference is needed; so dBV (relative to 1.0 volt) can be used for any impedance system.

**BATTERY OPERATION**—for field work, an instrument powered by internal batteries is necessary. If an area contains troublesome ground loops, a battery-powered instrument should be used to remove the ground path.

**SENSITIVITY VS. BANDWIDTH**—noise is a function of bandwidth. A voltmeter with a broad bandwidth will pick up and generate more noise and is less sensitive than one operating over a narrow range of frequencies. An instrument with a bandwidth of 10 Hz to 10 MHz has a sensitivity of 1 mV. On the other hand, a voltmeter whose bandwidth extends only to 4 MHz could have a sensitivity of 100  $\mu$ V.

### AC current measurements

AC current measurements can be made with a sensitive ac voltmeter and a series resistance, as described under "DC Measurements." Hewlett-Packard calibrated shunt resistors are designed for use with the 400 series meters, making these instruments direct-reading in current units.

The HP 456A Current Probe enables ac current to be measured without disturbing the circuit. This probe clips around the wire carrying the current to be measured and, in effect, makes the wire the one-turn primary of a transformer formed by ferrite cores and a many-turn secondary within the probe. The signal induced in the secondary is amplified in a battery-operated, solid-state amplifier; and the amplifier's voltage output can be applied to any suitable ac voltmeter for measurement. The amplifier constants are chosen so that 1 mA in the wire being measured produces 1 mV at the amplifier output. Current is read directly on the voltmeter.

The basic specifications for Hewlett-Packard analog voltmeters are summarized in Table I. To help you select a voltmeter suitable to your needs, our guidelines are restated as follows:

(1) For measurements involving dc applications, select the instrument with the broadest capability meeting your requirements.

(2) For ac measurements involving sine waves with only modest amounts of distortion (<10%), the average-responding voltmeter provides the best accuracy and most sensitivity per dollar.

(3) For high-frequency measurements (>10 MHz), the peak-responding voltmeter with the diode-probe input is the most economical choice. Peak-responding circuits are acceptable if inaccuracies caused by distortion in the input waveform can be tolerated.

(4) For measurements where it is important to determine the effective power of waveforms that depart from a true sinusoidal form, the true rms-responding voltmeter is the appropriate choice.

(5) For very wide bandwidths and high-sensitivity measurements of sinusoidal or non-sinusoidal waveforms, the new HP 3406A Sampling Voltmeter is the proper choice.

## Which analog voltmeter to select

DC VOLTMETERS		Voltage Range	Frequency Range Accuracy	Input Impedance	Model	See Page
DC NULL VOLTMETER Internal nulling supply battery operation dc amplifier, Ammeter		$\pm 3 \mu\text{V} - \pm 1 \text{ kV}$ end scale 0.1 $\mu\text{V}$ resolution (18 ranges)	dc $\pm 2\%$	100 k - 100 M $\Omega$ depending on range (infinite when nulled)	419A	186
DC NULL VOLTMETER Amplifier,		$\pm 1 \text{ mV} - \pm 1 \text{ kV}$ end scale (13 ranges)	dc $\pm 2\%$	10 M - 200 M $\Omega$ depending on range	413A	187
AC VOLTMETERS		Voltage Range	Frequency Range Accuracy	Response Input Impedance	Model	See Page
BATTERY OPERATED AC VOLTMETER		1 mV - 300 V (12 ranges)	1 Hz - 1 MHz $\pm 3\% - \pm 5\%$	Average 2 M $\Omega$ /15 - 40 pF	403A	195
RECHARGEABLE BATTERY AC VOLTMETER		1 mV - 300 V (12 ranges)	5 Hz - 2 MHz $\pm 2\% - \pm 5\%$	Average 2 M $\Omega$ /25 - 50 pF	403B	195
VACUUM-TUBE VOLTMETER, also useful as ac amplifier		1 mV - 300 V (12 ranges)	10 Hz - 4 MHz $\pm 2\% - \pm 5\%$	Average 10 M $\Omega$ /15 - 25 pF	400D	194
Similar to 400D except has 1% accuracy			$\pm 1\% - \pm 5\%$		400H	194
Similar to 400H except has linear 12 dB log scale		-70 dB - +52 dB (12 ranges)	$\pm 2\% - \pm 5\%$		400L	194
FAST-RESPONSE AC VOLTMETER 100 kHz low-pass filter ac amplifier		100 $\mu\text{V}$ - 300 V (14 ranges)	20 Hz - 4 MHz $\pm 1\% - \pm 4\%$	Average 10 M $\Omega$ /10 - 25 pF	400F	191
Similar to 400F except has linear 12 dB log scale		-92 dB - +52 dB	$\pm 1\% - \pm 4\%$		400FL	191
HIGH ACCURACY dB VOLTMETER 20 dB log scale (0 dB = 1 V)		-100 dB - +60 dB (8 ranges)	20 Hz - 4 MHz $\pm 2\% - \pm 4\%$	Average 10 M $\Omega$ /10 - 25 pF	400GL	192
HIGH ACCURACY AC VOLTMETER has dc output ( $\pm 0.5\%$ ) for driving DVM's or recorders), ac amplifier		1 mV - 300 V (12 ranges)	10 Hz - 10 MHz $\pm 1\% - \pm 4\%$	Average 10 M $\Omega$ /8 - 21 pF	400E	188
Similar to 400E except has linear 12 dB log scale uppermost		-70 dB - +52 dB (12 ranges)	$\pm 1\% - \pm 4\%$		400EL	188
RMS VOLTMETER provides rms readings of complex signals. Has dc output for driving DVM's or recorders		1 mV - 300 V (12 ranges)	10 Hz - 10 MHz $\pm 1\% - \pm 5\%$	10 M $\Omega$ /15 - 40 pF	3400A	196
SAMPLING RF VOLTMETER provides (true rms measurements when used with 3400A. Many accessories; hold button on probe to retain indication		1 mV - 3 V (8 ranges)	10 kHz - >1 GHz $\pm 3\% - \pm 8\%$	Statistical Average: Input Z depends on probe tip used	3406A	198
RF MILLIVOLTMETER		10 mV - 10 V (7 ranges)	500 kHz - 1 GHz $\pm 3\% - \pm 12\%$	Average Input Z depends on probe tip used	411A	197
VECTOR VOLTMETER phase and ampli- tude measurements		100 $\mu\text{V}$ - 10 V (9 ranges)	1 MHz - 1 GHz $\pm 0.5 \text{ dB} - \pm 1 \text{ dB}$	Average 0.1 M $\Omega$ /2.5 pF	8405A	240
MULTIFUNCTION METERS		Voltage Range (Accuracy)	Current Range (Accuracy)	Resistance Range (Accuracy)	Model	See Page
AUTOVOLTMETER has automatic ranging and polarity; input impedance 10 - 100 M $\Omega$		DC: $\pm 5 \text{ mV} - \pm 1500 \text{ V}$ ( $\pm 0.5\%$ f.s., $\pm 0.5\%$ rdg), 12 ranges		5 $\Omega$ - 1.5 M $\Omega$ ( $\pm 1\%$ rdg, $\pm 0.5\%$ f.s.) 12 ranges	414A	203
BATTERY-OPERATED MULTIFUNCTION METER, has 10 M $\Omega$ dc input impedance and 10 M $\Omega$ /20 pF ac input impedance		DC: $\pm 100 \text{ mV} - \pm 1000 \text{ V}$ ( $\pm 2\%$ ) 9 ranges AC: 10 mV - 300 V 10 Hz - 1 MHz ( $\pm 2\%$ ) 10 ranges		10 $\Omega$ - 10 M $\Omega$ midscale ( $\pm 5\%$ ) 7 ranges	427A	202
VERSATILE VOLTMETER has 100 M $\Omega$ dc input impedance and 10 M $\Omega$ /1.5 pF ac impedance		DC: $\pm 15 \text{ mV} - \pm 1500 \text{ V}$ ( $\pm 2\%$ ) 11 ranges AC: 0.5 V - 300 V 20 Hz - >700 MHz ( $\pm 3\%$ at 400 Hz) 7 ranges	DC: $\pm 1.5 \mu\text{A}$ to $\pm 150 \text{ mA}$ ( $\pm 3\%$ ) 11 ranges	10 $\Omega$ - 10 M $\Omega$ midscale ( $\pm 5\%$ ) 7 ranges	410C	200
VACUUM-TUBE VOLTMETER has 122 M $\Omega$ dc input impedance and 10 M $\Omega$ /1.5 pF ac impedance		DC: $\pm 1 \text{ V} - \pm 1000 \text{ V}$ ( $\pm 3\%$ ) 7 ranges AC: 1 - 300 V 20 Hz - 700 MHz ( $\pm 3\%$ ) 6 ranges		0.2 $\Omega$ - 500 M $\Omega$ ( $\pm 5\%$ ) 7 ranges	410B	200
DC VACUUM-TUBE VOLTMETER has 200 M $\Omega$ input impedance		DC: $\pm 1 \text{ mV} - \pm 1000 \text{ V}$ ( $\pm 1\%$ ) 13 ranges	DC: $\pm 1 \mu\text{A}$ to $\pm 1 \text{ A}$ ( $\pm 2\%$ ) 13 ranges	1 $\Omega$ - 100 M $\Omega$ ( $\pm 5\%$ of rdg) 9 ranges	412A	204
DC NULLMETER has 100 k $\Omega$ to 100 M $\Omega$ input impedance		DC: $\pm 3 \mu\text{V} - \pm 1 \text{ kV}$ end scale 18 ranges	DC: $\pm 30 \text{ pA}$ to $\pm 30 \text{ mA}$ ( $\pm 3\%$ ) 7 ranges		419A	186
DC MICROVOLT-AMMETER has 1 M $\Omega$ input impedance		DC: $\pm 10 \mu\text{V} - \pm 1 \text{ V}$ ( $\pm 3\%$ ) 11 ranges	DC: $\pm 10 \text{ pA}$ to $\pm 3 \text{ mA}$ ( $\pm 3\%$ ) 18 ranges		425A	205
CURRENT METERS		Current Range	Accuracy	Frequency Range	Model	See Page
DC MILLIAMMETER with clip-on probe eliminates direct connection		0.1 mA - 10 A f.s. (9 ranges)	$\pm 3\%$	dc-400 Hz	428B	206
AC CLIP-ON CURRENT PROBE makes measurements without breaking or load- ing circuit		1 mA - 1 A rms (to 25 A with divider)	$\pm 2\%$ to 3 dB	25 Hz - 20 MHz	456A	207



## VOLTAGE, CURRENT, RESISTANCE



## DC NULL METER & VOLTMETER Models 419A & 413A

### DC NULL METER Floating, 18 ranges, 0.1 $\mu$ V resolution Model 419A

#### Features:

- 18 ranges from 3  $\mu$ V to 1000 Vdc end scale
- 7 ranges from 30 pA to 30 nA end scale
- 0.1  $\mu$ V resolution
- 2%  $\pm$  0.1  $\mu$ V accuracy on all VM ranges
- High input impedance
- Solid state
- Rechargeable batteries

#### Uses:

- Sensitive null detector for bridge measurements
- Floating voltmeter measurements
- Thermocouple measurements
- General-purpose voltmeter and/or null detector
- DC amplifier

Eighteen voltage ranges with 0.1  $\mu$ V resolution on the lowest range set this HP solid state DC Null Voltmeter apart from previous dc null meters. The accuracy of this rechargeable battery-operated instrument is  $\pm 2\%$  of end scale  $\pm 0.1 \mu$ V on all ranges. Noise is less than 0.3  $\mu$ V p-p, and drift is less than 0.5  $\mu$ V/day.

An internal bucking source allows input voltages up to 300 mV to be nulled giving an infinite input impedance. Input impedance above the 300 mV range is 100 megohms.

#### Pushbutton selection provides convenience-versatility

Seven pushbuttons allow the operator to select rapidly the desired function of the HP 419A. This dc null voltmeter operates from the ac line or from the internal rechargeable batteries. During operation from the ac line the batteries are trickle-charged. A fast-charge pushbutton is provided to increase the charging rate, recharging the batteries in approximately 16 hours. Battery voltage may be easily checked with the battery-test pushbutton. The ZERO pushbutton enables the operator to compensate for any internal offsets before making a measurement. When this pushbutton is depressed, the positive leg of the voltmeter is disconnected from the positive input terminal and connected to the negative input terminal.

When the VM pushbutton is depressed the HP 419A functions as a zero-center scale 3  $\mu$ V to 1000 Vdc voltmeter.

When the AM pushbutton is depressed, the HP 419A functions as a zero-center scale 30 pA to 30 nA ammeter.

#### Voltmeter

**Ranges:**  $\pm 3 \mu$ V to  $\pm 1000$  volts dc end scale in 18 zero center ranges.

**Accuracy:**  $\pm 2\%$  of end scale  $\pm 0.1 \mu$ V.

**Limits of zero control:**  $\pm 15 \mu$ V.

**Input resistance:** 3  $\mu$ V to 3 mV ranges: 100 k ohms (infinite when nulled). 10 mV to 30 mV ranges: 1 megohm (infinite when nulled). 100 mV to 300 mV ranges: 10 megohms (infinite when nulled). 1 volt to 1000 volt ranges: 100 megohms.

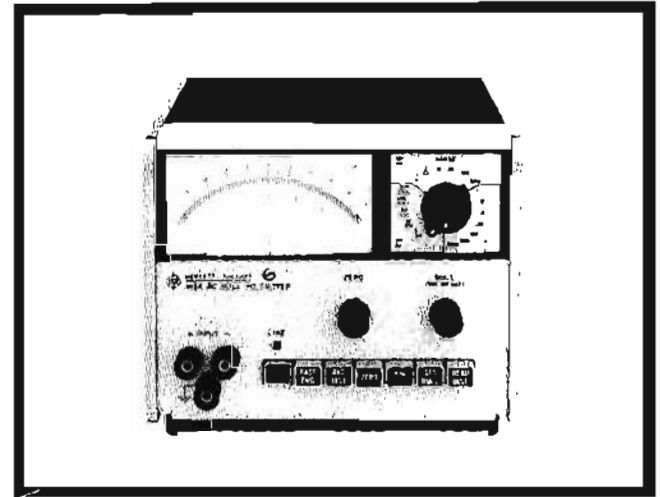

To eliminate measurement errors caused by high source impedances when the 3  $\mu$ V to 300 mV ranges are used, a SET NULL pushbutton is provided. When this pushbutton is depressed, an internal bucking voltage is placed in series with the input. A front-panel control enables the operator to null the input voltage with the HP 419A's bucking voltage. At this time the bucking voltage is equal to the input voltage resulting in an infinite input impedance and elimination of any loading error. The READ NULL pushbutton may then be depressed, disconnecting the input. The voltage of the bucking supply, which is the same as the input voltage, is now displayed on the meter. The bucking voltage is adjustable to approximately 120% of end scale on the 3  $\mu$ V to 300 mV ranges.

#### Convenience-versatility

The 419A's design, functional utility and light-weight modular construction contribute to its easy portability.

Rectangular pushbuttons are provided for ease of operation. Function ambiguity is prevented by mechanical interlocks which allow only one pushbutton to be depressed at one time.

#### Recorder amplifier

An output proportional to meter deflection makes the HP 419A an exceptionally stable dc amplifier. Its high-voltage gain, high stability and low noise make this dc null meter suitable for many control applications. For recording applications, one volt with currents up to 1 mA for full-scale meter indication is available at the rear output terminals.

#### Specifications

**Internal bucking voltage:** approximately  $\pm 120\%$  end scale, 3  $\mu$ V to 300 mV range.

**Response time:** 95% of final reading within 3 sec on the 3  $\mu$ V range. 95% of final reading within 1 sec on the 10  $\mu$ V to 1000 V ranges.

**Superimposed ac rejection:** ac voltages 60 Hz and above: 80 dB greater than end scale—affects reading less than 2%. Peak ac voltage not to exceed max. overload voltage.

**Noise:**\*  $< 0.3 \mu\text{V}$  peak-peak.

**Drift:**  $< 0.5 \mu\text{V}/\text{day}$  after 30 minutes warm-up. T.C.  $< .05 \mu\text{V}/^\circ\text{C}$  from  $0^\circ$  to  $+50^\circ\text{C}$ .

#### Amplifier

**Gain:** 110 dB maximum at recorder output terminals. Gain depends on range.

**Output:** 0 to  $\pm 1$  volt at 1 mA max. for end-scale reading. Output level is adjustable for convenience when used with recorders.

**Output impedance:** depends on setting of output level control.  $< 35$  ohms when output level is set to maximum.

**Noise:** 0.01 Hz to 5 Hz: Same as voltmeter (referred to input).  $> 5$  Hz: rms noise  $< 10$  mV (referred to output).

#### DC Ammeter

**Current ranges:**  $\pm 30 \mu\text{A}$ ,  $\pm 100 \mu\text{A}$ ,  $\pm 300 \mu\text{A}$ ,  $\pm 1 \text{ nA}$ ,  $\pm 3 \text{ nA}$ ,  $\pm 10 \text{ nA}$ , and  $\pm 30 \text{ nA}$ .

**Accuracy:**  $\pm 3\%$  of end scale  $\pm 1 \mu\text{A}$ .

**Input R:** 100 k $\Omega$ .

\* Noise amplitude approximates Gaussian distribution. Standard deviation (rms):  $\sigma = 0.075 \mu\text{V}$ . Peak to peak deviation (2 $\sigma$  limits): peak to peak deviation is  $< 0.3 \mu\text{V}$ , 95% of the time.

#### General

**Overload voltage:** 50 Vdc max, 3  $\mu\text{V}$  to 3 mV ranges; 500 Vdc max., 10 mV to 300 mV ranges; 1200 Vdc max. on 1 volt range and above.

**Overload recovery time:** meter indicates within 3 seconds for a  $10^3$  overload.

**Input terminals:** Positive and negative terminals are solid copper, gold flashed.

**Input isolation:**  $> 10^{10}$  ohms shunted by 250 pF. May be operated up to 500 Vdc or 350 Vac (rms) above ground.

**Operating temperature:**  $0^\circ$  to  $+50^\circ\text{C}$ .

**Storage temperature:**  $-40^\circ\text{C}$  to  $+60^\circ\text{C}$ .

**Power source:** 4 internal rechargeable batteries (furnished). Thirty hour operation per recharge. The 419A may be operated during recharge from ac line. 115 or 230 V  $\pm 10\%$ , 50 to 1000 Hz, approximately 3 watts.

**Dimensions:** standard HP  $\frac{1}{2}$  module; 6" high,  $7\frac{3}{4}$ " wide, 8" deep (152 x 197 x 203 mm).

**Weight:** net: 8 lbs (3.6 kg). Shipping: 11 lbs (5 kg).

**Price:** HP 419A, \$450.

## DC NULL VOLTMETER

Floating, high-impedance input; 1 mV end-scale sensitivity

### Model 413A

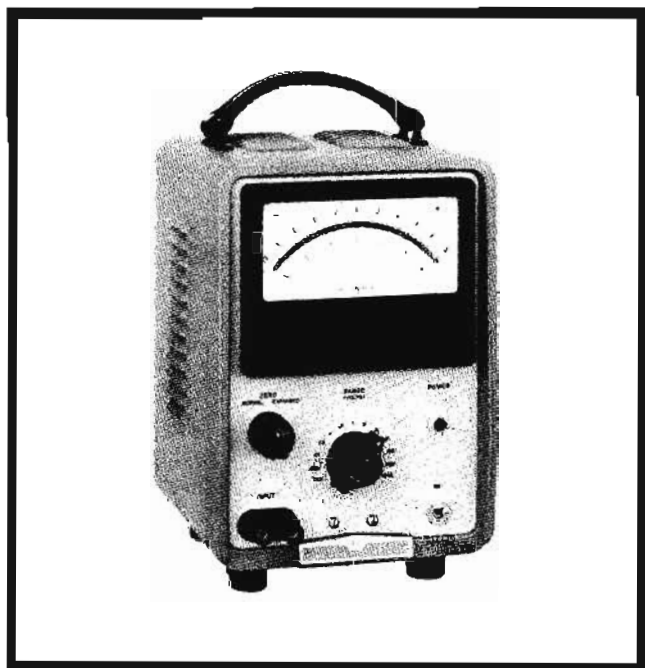

The 413A has 13 zero-centered ranges running from 1 mV to 1000 V end scale.

High input impedance (10 megohms on the most sensitive range, 200 megohms on the 300 mV range and above) makes the 413A especially valuable in resistance bridge measurements. Accuracy of this instrument is within 2% of end scale; drift and noise are virtually imperceptible.

### Specifications

#### Voltmeter

**Range:** positive and negative voltages from 1 mV to 1000 volts end scale in 13 zero-center ranges.

**Accuracy:**  $\pm 2\%$  of end scale.

**Limits of zero control:** more than  $\pm$  end scale on any range when using expanded scale.

**Input resistance:** 10 megohms on 1, 3 and 10 mV ranges; 30 megohms on 30 mV range; 100 megohms on 100 mV range; 200 megohms on 300 mV range and above.

**AC rejection:** a voltage at power line or twice power-line frequency 40 dB greater than end scale affects reading  $< 1\%$ ; peak voltage must not exceed 1500 volts.

#### Amplifier

**Gain:** 0.001 to 1000 in 13 steps.

**Gain accuracy:**  $\pm 1.5\%$ .

**Linearity:**  $\pm 0.2\%$ .

**Noise:** less than 2  $\mu\text{V}$  rms (typically less than 15  $\mu\text{V}$  p-p) referred to the input.

**Output:** 1 V for end-scale deflection, same polarity as input signal; end scale corresponds to 1 on upper scale; maximum load current is 1 milliamp.

**Output impedance:** less than 2 ohms at dc.

**Output terminals:** dual banana jacks.

**AC rejection:** approximately 3 dB at 1 Hz, 80 dB at 50 and 60 Hz.

#### General

**Input terminals:** dual banana jacks.

**Input isolation:** greater than 100 megohms shunted by 0.1  $\mu\text{F}$  to case (power line ground).

**Common signal rejection:** may be operated with up to 500 Vdc or 130 Vac above ground.

**Power:** 115 or 230 volts  $\pm 10\%$ , 50 to 60 Hz, approximately 35 watts.

**Dimensions:** cabinet:  $11\frac{1}{2}$ " high,  $7\frac{1}{2}$ " wide, 10" deep (292 x 110 x 254 mm); rack mount:  $5\text{-}7/32$ " high, 19" wide,  $6\frac{3}{8}$ " deep (134 x 483 x 168 mm).

**Weight:** cabinet: net 12 lbs (5.4 kg); shipping, 14 lbs (6.4 kg).

Rack mount: net 12 lbs (5.4 kg); shipping, 19 lbs (8.6 kg).

**Price:** HP 413A, \$350 (cabinet); \$355 (rack mount).

# VOLTAGE, CURRENT, RESISTANCE



## AC VOLTMETERS

Measure 10 Hz to 10 MHz, 1 mV to 300 V

Models 400E, EL

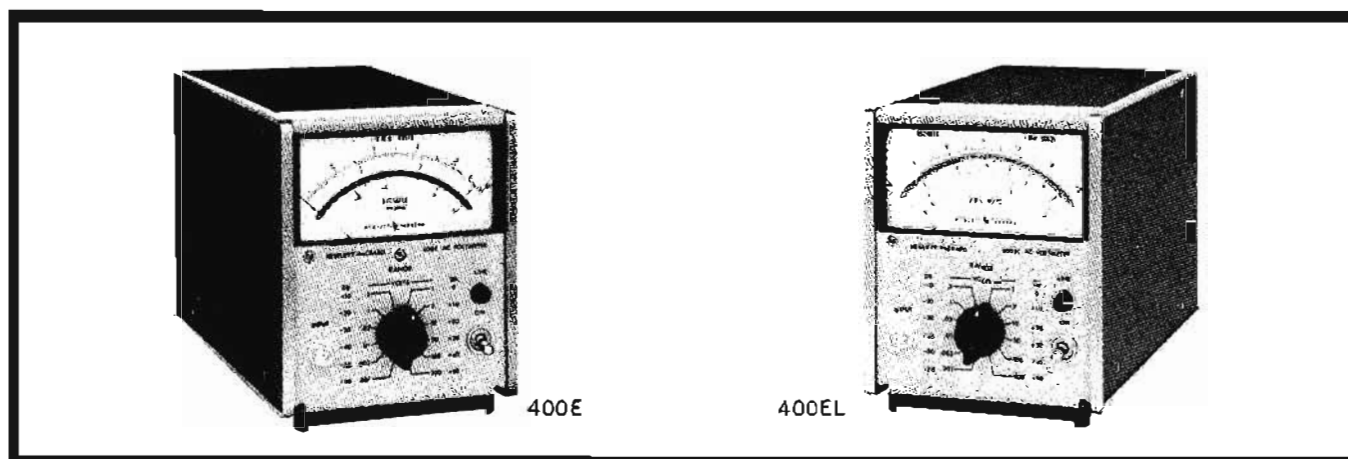

### Description

The HP 400E/EL Solid-State AC Voltmeters are ruggedly built precision instruments for measuring ac voltages from 1 millivolt to 300 V rms full scale. They cover a frequency range from 10 Hz to 10 MHz and have constant 10 megohm input resistance on all ranges. Input capacity is 21 pF on the 1 mV to 1 volt range and 8 pF on the 3 volt to 300 volt range. The instruments are simple to operate and give direct voltage and dBm readings.

These ac voltmeters have exceptional long-term stability because their calibration is not dependent on active component parameters which are subject to aging. The 400E/EL may also be used as stable, high-gain ac amplifiers or ac-to-dc converters.

The 400E has all the characteristics mentioned above with 1% of reading accuracy on a  $4\frac{1}{2}$ " mirror-backed, taut-band meter. The meter is individually calibrated with 100 divisions to provide greater resolution.

The 400EL has all the characteristics above with 1% of reading accuracy on a linear 12 dB logarithmic scale. This meter is also individually calibrated with 120 divisions and is ideal for dB measurements.

### Battery operation

The Models 400E/EL can be operated from two 35 to 55-volt batteries connected to the rear panel battery terminals. This feature is ideal for communications usage or when troublesome ground loops are prevalent.

### Options

*Special dB-measuring option*—The Model 400E reads directly in volts and dB, with the voltage scale uppermost. The Model 400E (Option 01) with dB scale uppermost is recommended for greater resolution in dB measurements.

### High gain amplifier

Additionally, the 400E and 400EL provide a stable low-distortion, high-gain, wideband ac amplifier with a 50-ohm output impedance.

### AC-to-DC converter

The Models 400E/EL provide a linear dc output (1 volt dc for full-scale meter deflection) proportional to meter deflection which can be used to drive a potentiometer or galvanometer recorder. The accuracy is  $\pm 0.5\%$  making the 400E/EL an excellent ac-to-dc converter. This dc output is available at the rear panel of the instrument; see specifications.

### Specifications 400E, EL

#### 3 MV-300 V RANGES

Frequency 10 Hz 20 Hz 40 Hz 100 Hz 500 kHz 2 MHz 1 MHz 4 MHz 10 MHz

	10 Hz	20 Hz	40 Hz	100 Hz	500 kHz	2 MHz	1 MHz	4 MHz	10 MHz
AT FULL SCALE	$\pm 4$	$\pm 2$	$\pm 1$	$\pm 0.5^*$	$\pm 1$	$\pm 2$	$\pm 2$	$\pm 4$	$\pm 4$ †
AT 1/3 FULL SCALE	+4 -10	+2 -4	$\pm 1$			$\pm 2$	+2 -4	+3 -10	

#### 1 MV RANGE

Frequency 10 Hz 20 Hz 40 Hz 100 Hz 100 kHz 500 kHz 2 MHz 6 MHz 200 kHz 1 MHz 4 MHz

	10 Hz	20 Hz	40 Hz	100 Hz	100 kHz	500 kHz	2 MHz	6 MHz
AT FULL SCALE	+4 -10	$\pm 2$	$\pm 1$	$\pm 0.5^*$	$\pm 1$	$\pm 2$	$\pm 4$	+4 -10
AT 1/3 FULL SCALE	+4 -10	+2 -4	$\pm 1$			$\pm 2$	+2 -4	+3 -10
AT 1/10 FULL SCALE		+4 -15	+4 -10	$\pm 4$		+4 -10	+4 -15	+4 -30

\*For 15°C-40°C on 1 mV-1 volt ranges only

†For 100 and 300 volt ranges +4, -10%

## Specifications

Model	400E	400EL
Voltage range	1 mV to 300 V full scale, 12 ranges	
Frequency range	10 Hz to 10 MHz	
Calibration	reads rms value of sine wave; voltage indication proportional to absolute average value of applied wave; dB scale -10 to +2 dB, 10 dB between ranges; 100 divisions on 0 to 1 scale.	reads rms value of sine wave; voltage indication proportional to absolute average value of applied wave; linear dB scale -10 dB to +2 dB, 10 dB between ranges; logarithmic voltage scales 0.3 to 1 and 0.8 to 3; 120 divisions from -10 to +2 dB.

## HP MODEL 400E

## ACCURACY % Of Reading

## 3 MV to 300 V RANGES

Frequency 10 Hz 20 Hz 40 Hz 500 kHz 2 MHz 1 MHz 4 MHz 10 MHz

AT FULL SCALE	±4	±2	±1				±2	±4 <sup>†</sup>
AT 1/3 FULL SCALE	+4 -10	+3 -5	±3				+3 -4	+3 -5 +4 -10

## ACCURACY % Of Reading

## 1 MV RANGE

Frequency 10 Hz 20 Hz 40 Hz 100 Hz 100 kHz 500 kHz 2 MHz 6 MHz 200 kHz 2 MHz 4 MHz

AT FULL SCALE	+4 -10	±2	±1				±2	±4	+4 -10
1/3 FULL SCALE	+4 -10	+3 -5	±3				+3 -4	+3 -5	+3 -10
AT 1/10 FULL SCALE		+10 -20	+10 -15	±10		+10 -15	+10 -20	+10 -30	

## HP MODEL 400EL

## ACCURACY % Of Reading

## 3 MV to 300 V RANGES

Frequency 10 Hz 20 Hz 40 Hz 500 kHz 2 MHz 1 MHz 4 MHz 10 MHz

AT FULL SCALE	±4	±2	±1				±2	±4	†
AT 1/3 FULL SCALE	+4 -10	+2 -4	±1.5				±2	+2 -4	+3 -10

## 1 MV RANGE

Frequency 10 Hz 20 Hz 40 Hz 500 kHz 2 MHz 6 MHz 200 kHz 1 MHz 4 MHz

AT FULL SCALE	+4 -10	±2	±1				±2	±4	+4 -10
AT 1/3 FULL SCALE	+4 -10	+2 -4	±1.5				±2	+2 -4	+3 -10

<sup>†</sup>For 100 and 300 volt ranges +4, -10%

## HP Model 400E/EL

**Input Impedance:** 10 megohms shunted by 21 pF on the 1 mV-1V ranges and 10 megohms shunted by 8 pF on the 3V-300V ranges.

**Amplifier ac output:** 150 mV rms for full-scale meter indication; output impedance 50 ohms, 10 Hz to 10 MHz (105 mV on the 1 mV range).

**AC-dc converter output:** 1 Vdc output for full-scale meter deflection. (linear output for models 400E/EL).

**Output resistance:** 1000 ohms.

**Response time:** 1 second to within 1% of final value for a step change.

**AC power:** 115 or 230 volts ±10%, 50 to 1000 Hz, approx. 5 watts.

**Temperature range:** 0 to +55°C (except where noted on accuracy charts).

**External battery operation:**

Terminals are provided on rear panel; positive and negative voltages between 35 V and 55 V are required; current drain from each voltage is approx. 54 mA. (External switching and on/off monitoring should be used for battery operation.)

**Weight:** net 6 lbs (2,7 kg), shipping 8 lbs (3,6 kg).

**Dimensions:** (Std. HP 1/3 module) 6 1/2" high, 5 1/8" wide, 11" deep (165,1 x 130,2 x 279,4 mm).

**Price:** HP Model 400E, \$285.

HP Model 400EL, \$295.

**VOLTAGE, CURRENT,  
RESISTANCE**



**AC VOLTMETER**

Measure 20 Hz to 4 MHz, 100  $\mu$ V to 300 V  
Models 400F, FL

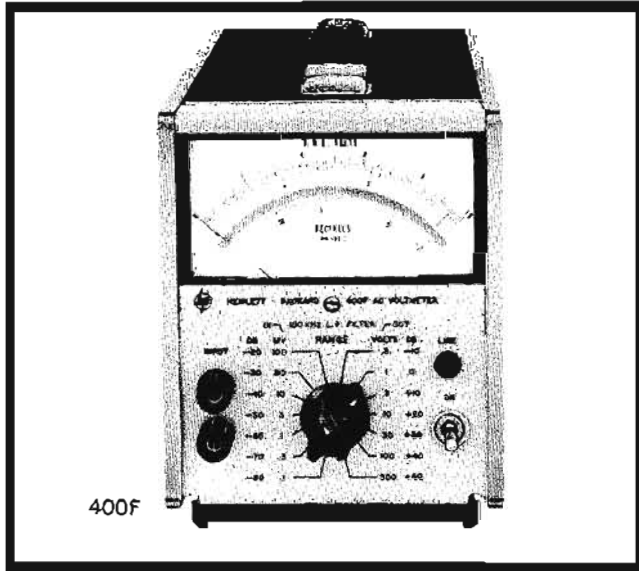

**Description**

The HP 400F/FL solid-state ac voltmeters are ruggedly-built precision instruments for measuring ac voltages from 100 microvolts to 300 V rms full scale. They cover a frequency range from 20 Hz to 4 MHz and have constant 10 megohm input resistance on all ranges. Input capacity is 25 pF on the 100  $\mu$ V to 300 mV range and 10 pF on the 1 volt to 300 volt range. The instruments are simple to operate and give direct voltage and dBm readings.

These ac voltmeters have exceptional long-term stability because their calibration is not dependent on active component parameters which are subject to aging. The 400F/FL may also be used as stable, high-gain ac amplifiers with up to 80 dB amplification.

The 400F has all the characteristics mentioned above with 1/2% of reading plus 1/2% of full-scale accuracy on a 4 1/2" mirror-backed taut-band meter. The meter is individually calibrated with 100 divisions to provide greater resolution.

The 400FL has all the characteristics above with 1% of reading accuracy on a linear 12 dB logarithmic scale. This meter is also individually calibrated with 120 divisions and is ideal for dB measurements.

The specifications in the chart on the next page show these compact, lightweight, solid-state voltmeters will give premium performance at an economical price.

*Special dB measuring option (400F only—The Model 400F reads directly in volts and dB, with the voltage scale uppermost. The Model 400F (Option 01.) with dB scale uppermost is recommended for greater resolution in dB measurements.*

**Battery operation**

The Model 400F/FL can be operated from two 35 to 55-volt batteries connected to the rear-panel battery terminals. This feature is ideal for communications usage or when ground loops cause trouble.

**High gain amplifier**

The 400F/FL is also a stable, low-distortion, wideband ac amplifier, with a maximum open-circuit gain of 80 dB. The ac output is 1 volt rms (full scale) open circuit or 0.5 volts rms into 600 ohms and is proportional to meter indication on the voltage scale. Frequency response is from 20 Hz to 4 MHz.

**Logarithmic Model 400FL**

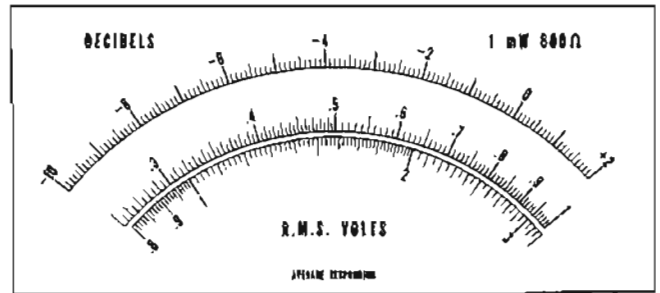

Meter Face for 400FL

The HP 400FL is designed for greater resolution in dB measurements. The voltage scale is calibrated to  $\pm 1\%$  of reading accuracy. This instrument is useful for acoustical and communications applications. It incorporates an HP taut-band, mirror-backed, logarithmic meter. A range switch changes sensitivity in 10 dB steps which, combined with the 12 dB scale, provides the overlap desirable in decibel-level measurements.

**100 kHz low pass filter**

In order to reduce the effect of unwanted high frequencies (noise, etc.) on the accuracy of measuring lower frequency signals, a 100 kHz low-pass filter is provided. It may be activated by a front-panel switch. The filter is effective on all ranges but will be of greater use on more sensitive ranges, and has 3 dB of attenuation at 100 kHz  $\pm 5$  kHz.

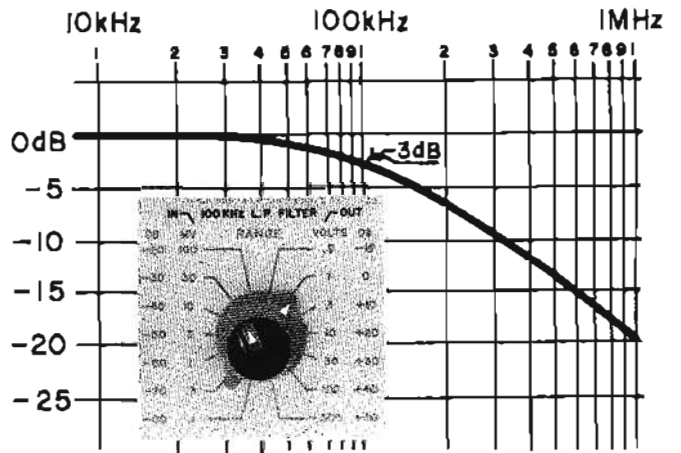

**Easy to use**

A front panel range switch which changes sensitivity in 10 dB steps, combined with the dB calibration of the meter, permits reading of dBm directly without calibration or conversion in the range -92 to +52 dBm (0 dBm = 1 milliwatt into 600 ohms). In addition, the 10 dB range spacing provides 2 voltage scales so that readings are al-

ways greater than one-third full scale. This provides the highest possible readability and accuracy.

The Voltage Divider Probe (HP 11074A) with a banana post to BNC adapter (HP 10111A) provides low input capacitance and high input resistance at the point of measurement when using the 400F/FL.

**Specifications**

HP Model	400F	400FL
Voltage range	100 $\mu$ V to 300 V full scale, 14 ranges	
Frequency range	20 Hz - 4 MHz	
Calibration	reads rms value of sine wave; voltage indication proportional to absolute average value of applied wave; dB scale -10 to +2 dB, 10 dB between ranges; 100 divisions on 0 to 1 scale.	reads rms value of sine wave; voltage indication proportional to absolute average value of applied wave; linear dB scale -10 dB to +2 dB, 10 dB between ranges; logarithmic voltage scales 0.25 to 1 and 0.8 to 3; 120 divisions from -10 to +2 dB.

**HP MODEL 400F**

ACCURACY\*% Full Scale Plus % Reading

**300  $\mu$ V to 300 V RANGES**

Frequency	20 Hz	40 Hz	100 Hz	1 MHz	2 MHz	4 MHz
	$\pm(2 + 2)$	$\pm(1 + 1)$	$\pm(1/2 + 1/2)$	$\pm(1 + 1)$	$\pm(2 + 2)$	

**100  $\mu$ V RANGE**

Frequency	30 Hz	60 Hz	100 kHz	500 kHz
	$\pm(2 + 2)$	$\pm(1 + 1)$	$\pm 1$	$\pm 1$

**HP MODEL 400FL**

ACCURACY\*% Reading

**300  $\mu$ V to 300 V RANGES**

Frequency	20 Hz	40 Hz	100 Hz	1 MHz	2 MHz	4 MHz
	$\pm 4$	$\pm 2$	$\pm 1$	$\pm 2$	$\pm 4$	

**100  $\mu$ V RANGE**

Frequency	30 Hz	60 Hz	100 kHz	500 kHz
	$\pm 4$	$\pm 2$	$\pm 1$	$\pm 1$

**400F/FL**

**Noise\***

Noise referred to input (1000 $\Omega$  termination).

	Filter In	Filter Out
300 $\mu$ V - 300 V	<5 $\mu$ V	<30 $\mu$ V
100 $\mu$ V Range	<5 $\mu$ V	<15 $\mu$ V

Note: Noise adds to the signal approximately by the relation:  
Reading =  $\sqrt{(\text{signal})^2 + (\text{noise})^2}$

**Input impedance:** 10 megohms shunted by 25 pF on the 100  $\mu$ V - 300 mV ranges and 10 megohms shunted by 10 pF on the 1 V - 300 V ranges.

**Amplifier ac output:** 1 V rms open circuit (full scale) and is proportional to meter indication on the voltage scale; output impedance: 600 ohms; frequency response: 20 Hz to 4 MHz.

**Recovery from overload:** <2 seconds for 80 dB overload (300 V max. input).

**Meter response:** <0.7 seconds after application of signal.

**AC power:** 115 or 230 volts  $\pm$ 10%, 50 to 1000 Hz, approx. 5 watts.

**Temperature range:** 0 to +55 $^{\circ}$ C.

**External battery operation:**

Terminals are provided on rear panel; positive and negative voltages between 35 V and 55 V are required; current drain from each voltage is approx. 45 mA. (External switching and on/off monitoring should be used for battery operation.)

**Weight:** net 6 lbs (2,7 kg), shipping: 8 lbs (3,6 kg).

**Dimensions:** (standard HP 1-3 module) 6 1/2" high, 5 1/8" wide, 11" deep (165,1 x 130,2 x 279,4 mm).

**Price:** Model 400F, \$275.

Model 400FL, \$285.

**VOLTAGE, CURRENT,  
RESISTANCE**



## AC VOLTMETER

Log meter offers  $-100$  to  $+60$  dB measurements  
Model 400GL

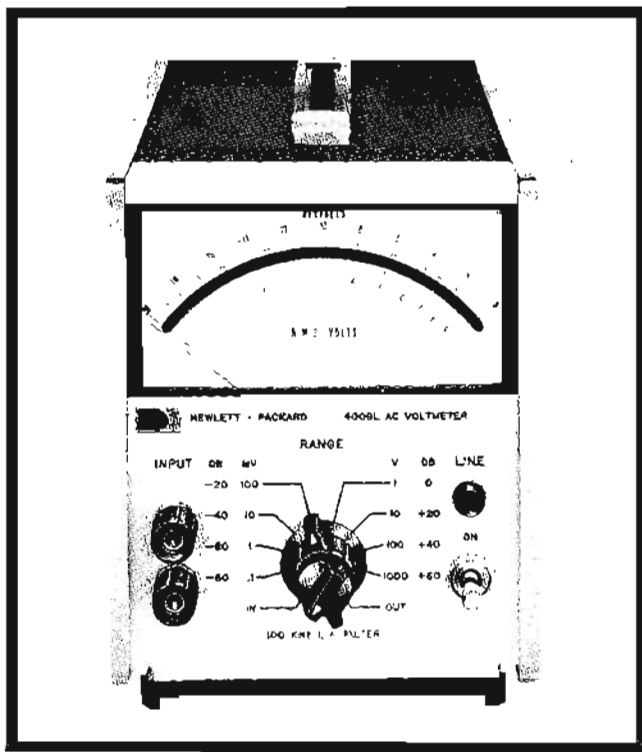

### Description

The 400GL Solid-State AC Voltmeter is a ruggedly built precision instrument for measuring ac voltages from 100 microvolts to 1000 V rms full scale. It covers a frequency range from 20 Hz to 4 MHz and has a constant 10 megohm input resistance on all ranges. Input capacity is 25 pF on the 100  $\mu$ V range to the 100 mV range and 10 pF on the 1 volt to 1000 volt range. The instrument is simple to operate and gives direct voltage and dB readings.

The 400GL has  $\pm 0.2$  dB of reading accuracy on a linear 20 dB logarithmic scale individually calibrated with 100 divisions.

The long-term stability of this instrument is exceptional because its calibration is not dependent on active component parameters which are subject to aging. The 400GL may also be used as a stable, high-gain ac amplifier with up to 80 dB amplification.

The specifications in the chart on the next page show this compact, lightweight, solid-state voltmeter will give premium performance at an economical price.

The HP 400GL is designed for greater resolution in dB measurements and is useful for acoustical and communications applications. It incorporates an HP taut-band, mirror-backed, logarithmic meter. For utmost accuracy, the meter scale is individually calibrated, using the new HP logarithmic meter calibrator. The meter scale provides maximum readability and  $\pm 0.2$  dB of reading accuracy. The decibel scale is more than  $4\frac{3}{8}$ " long, and the voltage scale spreads across the full length.

### Uses:

Measure voltages: 20 Hz to 4 MHz, 100  $\mu$ V to 1000 V full scale

Use as a high-gain AC amplifier (80 dB max.)

### Features:

Accuracy  $\pm 0.2$  dB

Fast response

Switchable 100 kHz low pass filter

Rapid overload recovery

Low input capacity (10-25 pF)

Individually calibrated taut band meter

Temperature range: 0 to 55°C

10 megohm input impedance

Solid state

Battery operable

### Easy to use

A front-panel range switch which changes sensitivity in 20 dB steps, combined with the dB calibration of the meter, permits reading of dB directly without calibration or conversion in the range  $-100$  to  $+60$  dB (0 dB=1 volt).

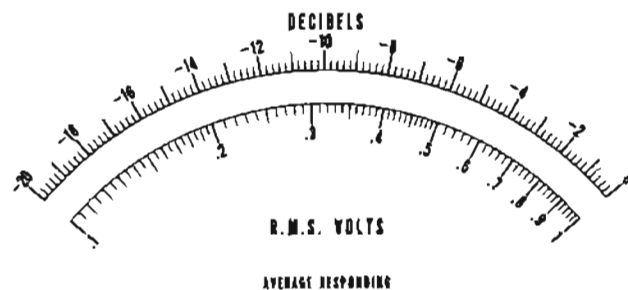

Figure 2. Meter face on Model 400GL.

### Battery operation

The Model 400GL can be operated from two 35 to 55 volt batteries connected to the rear-panel battery terminals. This feature is ideal for communications usage or when ground loops cause trouble.



**High gain amplifier**

In addition, the 400GL provides a stable low distortion, high gain, wideband ac amplifier with a maximum open-circuit gain of 80 dB. The ac output is 1 volt rms (full scale) open circuit or 0.5 volts rms into 600 ohms and is proportional to meter indication on the voltage scale. Frequency response is from 20 Hz to 4 MHz.

**100 kHz low pass filter**

In order to reduce the effect of unwanted high frequencies (noise, etc.) on the accuracy of measuring lower frequency signals, a 100 kHz low-pass filter is provided. The filter may be activated by a front-panel switch and has 3 dB of attenuation at 100 kHz  $\pm$  5 kHz. The filter is effective on all ranges but will be of greater use on more sensitive ranges.

**Specifications**

**HP MODEL 400GL**  
Accuracy of Reading\*

**1 mV - 1000 V\*\* Ranges**

Frequency	20 Hz	40 Hz	500 kHz	2 MHz	4 MHz
	$\pm 0.4$ dB	$\pm 0.2$ dB	$\pm 0.4$ dB	$+0.2$ dB $-0.8$ dB	

**100  $\mu$ V Range-**

Frequency	30 Hz	60 Hz	100 kHz	500 kHz
	$\pm 0.4$ dB	$\pm 0.2$ dB	$+0.2$ dB $-0.8$ dB	

\*\*For input voltages greater than 300 volts, the high frequency range is limited to 100 kHz.

**Voltage range:** 100  $\mu$ V to 1000 V full scale, 8 ranges.

**Frequency range:** 20 Hz to 4 MHz.

**Calibration:** reads rms value of sine wave; voltage indication proportional to absolute average of applied wave; linear dB scale  $-20$  to  $0$  dB. 20 dB between ranges; logarithmic voltage scales. 0.1 to 1; 100 divisions from  $-20$  to  $0$  dB.

**Noise\***

**Noise referred to Input** (1000 $\Omega$  termination).

	Filter In	Filter Out
1 mV - 1000 V	<5 $\mu$ V	<30 $\mu$ V
100 $\mu$ V Range	<5 $\mu$ V	<15 $\mu$ V

Note: Noise adds to the signal approximately by the relation:

$$\text{Reading} = \sqrt{(\text{signal})^2 + (\text{noise})^2}$$

**Recovery from overload:** < 2 seconds for 80 dB overload (1200 V max. input).

**Input impedance:** 10 megohms shunted by 25 pF on the 100  $\mu$ V - 100 mV ranges and 10 megohms shunted by 10 pF on the 1 V - 1000 V ranges.

**Amplifier ac output:** 1 V rms open circuit (full scale) and is proportional to meter indication on the voltage scale; output impedance 600 ohms. Frequency response 20 Hz to 4 MHz.

**AC power:** 115 or 230 volts  $\pm 10\%$ , 50 to 1000 Hz, approximately 5 watts.

**Temperature range:** 0 to  $+55^\circ\text{C}$ .

**External battery operation:** terminals are provided on rear panel; positive and negative voltages between 35 V and 55 V are required; current drain from each battery is approximately 45 mA. (External switching and on/off monitoring should be used for battery operation.)

**Weight:** net: 6 lbs (2,7 kg); shipping: 9 lbs (4 kg).

**Dimensions:** (standard  $\frac{1}{3}$  module) 6 $\frac{1}{2}$ " high, 5 $\frac{1}{8}$ " wide, 11" deep (165,1 x 130 x 279,4 mm).

**Price:** HP Model 400GL, \$290.

**VOLTAGE, CURRENT,  
RESISTANCE**



## VACUUM TUBE VOLTMETERS

Quality linear and log voltmeters

Models 400D, 400H, 400L

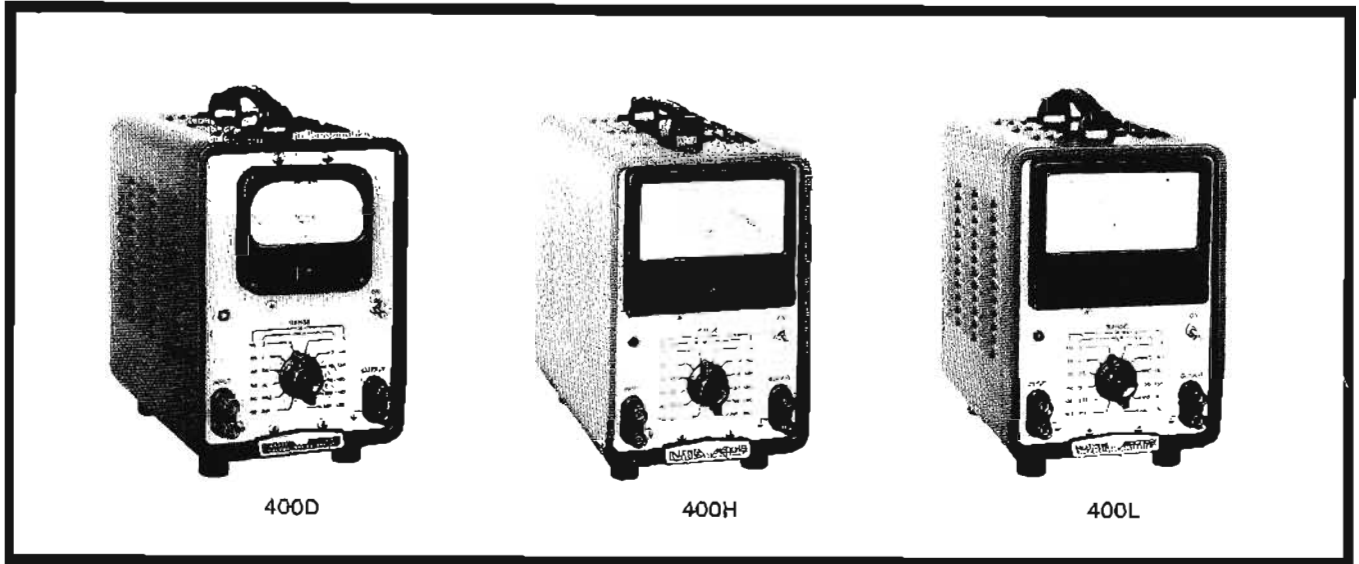

### Description

Model 400D is essentially a low-priced precision voltmeter offering wide voltage range, 2% accuracy and the broad frequency coverage 10 Hz to 4 MHz.

Model 400H is an adaptation of Model 400D but offering individual meter-face calibration and 1% accuracy on an extra large 5" mirror-scale meter.

Model 400L, a logarithmic version of Model 400D, has an

accuracy of  $\pm 2\%$  of reading or  $\pm 1\%$  of full scale, whichever is more accurate. The 5" meter is mirror-backed.

### Special dB-measuring options

As normally supplied, Models 400D and 400H read direct in volts and dB, with the voltage scale uppermost. For greater resolution in dB measuring, these instruments are available as Models 400D Option 01, and 400H Option 01 (\$25 extra) with the dB meter scale uppermost.

### Specifications

	400D,DR	400H,HR	400L,LR
Voltage range:	1.0 mV to 300 V full scale, 12 ranges	1.0 mV to 300 V full scale, 12 ranges	-70 dB to +52 dB in 12 ranges 1.0 mV to 300 V full scale, 12 ranges
Frequency range:	10 Hz to 4 MHz		
Accuracy: (as % of full scale on 400D,DR and 400H,HR)	$\pm 2\%$ , 20 Hz to 1 MHz $\pm 3\%$ , 20 Hz to 2 MHz $\pm 5\%$ , 10 Hz to 4 MHz	$\pm 1\%$ , 50 Hz to 500 kHz $\pm 2\%$ , 20 Hz to 1 MHz $\pm 3\%$ , 20 Hz to 2 MHz $\pm 5\%$ , 10 Hz to 4 MHz	$\pm 2\%$ of reading or $\pm 1\%$ of full scale, whichever is more accurate, 50 Hz to 500 kHz; $\pm 3\%$ of reading or $\pm 2\%$ of full scale, 20 Hz to 1 MHz; $\pm 4\%$ of reading or $\pm 3\%$ of full scale, 20 Hz to 2 MHz; $\pm 5\%$ of reading, 10 Hz to 4 MHz
Long-term stability:	reduction in Gm of amplifier tubes to 75% of nominal value results in error of less than 0.5%, 50 Hz to 1 MHz		
Calibration:	reads rms value of sine wave; voltage indication proportional to average value of applied wave; linear voltage scale 0 to 3 and 0 to 1; dB scale -12 to +2 dB (0 dB = 1 mW in 600 ohms); 10 dB interval between ranges		reads rms value of sine wave; logarithmic voltage scale 0.3 to 1 and 0.8 to 3; linear dB scale, -10 dB to +2 dB (based on 0 dB = 1 mW in 600 ohms); 10 dB intervals between ranges
Input impedance:	10 megohms shunted by 15 pF on ranges 1 to 300 V; 25 pF on ranges 0.001 to 0.3 V		
Amplifier:	output approx. 0.15 V max.; internal impedance 50 ohms; max. gain approx. 150 on 0.001 range		
Power:	115 or 230 volts $\pm 10\%$ , 50 to 1,000 Hz; approx. 80 watts (100 watts for 400 H,L)		
Dimensions:	cabinet mount: 7½" wide, 11½" high, 12" deep (191 x 292 x 305 mm); rack mount: 19" wide, 7" high, 10⅞" deep behind panel (483 x 389 x 276 mm)		
Weight:	net 18 lbs (8,1 kg), shipping 19 lbs (8,6 kg) (cabinet mount); net 21 lbs (9,45 kg), shipping 31 lbs (14 kg) (rack mount)		
Price:	HP 400D, \$250* HP 400DR, \$255**	HP 400H, \$325* HP 400HR, \$330**	HP 400L, \$325* HP 400LR, \$330**

\*Cabinet.

\*\*Rack mount.

## AC VOLTMETERS

Solid-state, battery-operated, portable  
Model 403A, B



**VOLTAGE, CURRENT,  
RESISTANCE**

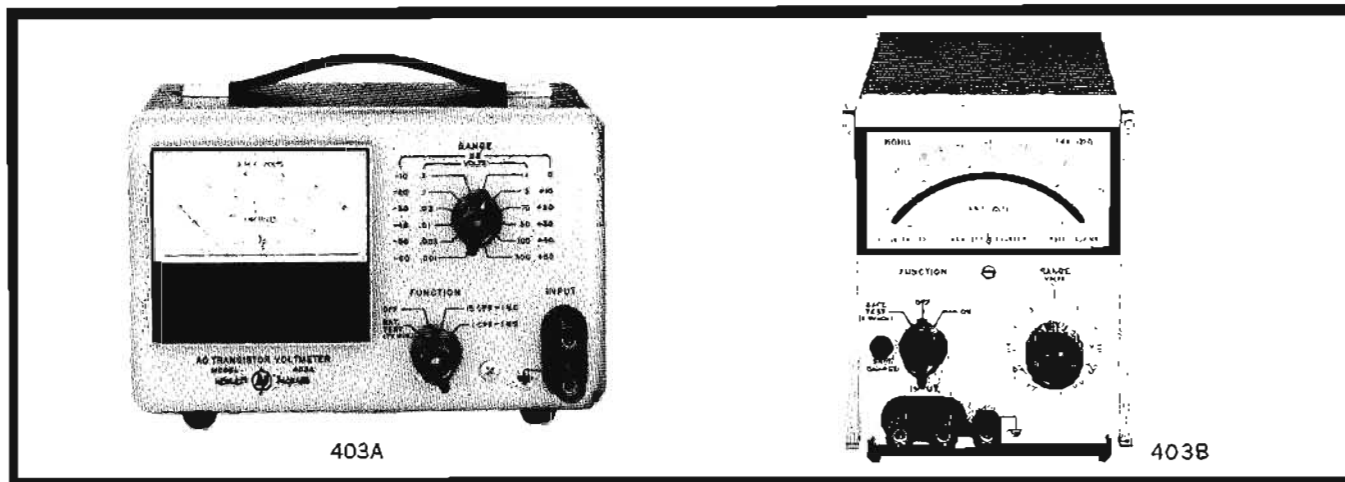

### Description

Models 403A and 403B AC voltmeters are versatile, general-purpose instruments for laboratory and production work and are ideal for use in the field, since they are solid-state, battery-operated and portable.

Both measure from 100 microvolts to 300 volts, the 403A covering 1 Hz to 1 MHz and the 403B covering 5 Hz to 2 MHz. Both operate from internal batteries and, thus, may be completely isolated from the power-line and external grounds, permitting accurate measurements at power-line frequency and its harmonics, without concern for beat effects. Isolation from external ground also permits use where ground loops are troublesome. Turnover effect and waveform errors

are minimized, because the meters respond to the average value of the input signal.

The 403B operates from an ac line, as well as from the internal battery pack, and batteries recharge during ac operation. Battery charge may be easily checked with a front-panel switch to assure reliable measurements. Normally, about 15 hours of ac operation recharges the batteries; but an internal adjustment is provided which nearly doubles the charging rate. You can use the Model 403B while its batteries charge. A sturdy taut-band meter eliminates friction and provides greater precision and repeatability.

For improved resolution in dB measurements, the 403B Option 01 is available. This version spreads out the dB scale by making it the top scale of the meter.

### Specifications

HP Model	403A	403B	403B (Option 01.)
Frequency range	1 Hz to 1 MHz	5 Hz to 2 MHz	5 Hz to 2 MHz
Accuracy	within $\pm 3\%$ of full scale, 5 Hz to 500 kHz; within $\pm 5\%$ of full scale, 1 to 5 Hz and 500 kHz to 1 MHz	within $\pm 2\%$ of full scale from 10 Hz to 1 MHz; within $\pm 5\%$ of full scale from 5 to 10 Hz and 1 to 2 MHz, except $\pm 10\%$ 1 to 2 MHz on the 300 V range (0 to 50°C)*	within $\pm 0.2$ dB of full scale from 10 Hz to 1 MHz; within $\pm 0.4$ dB of full scale from 5 to 10 Hz and 1 to 2 MHz, except $\pm 0.8$ dB 1 to 2 MHz on the 300 V range (0 to 50°C)*
Nominal input impedance	2 megohms; shunted by approx. 40 pF, 0.001 to 0.1 V ranges; 20 pF, 0.3 to 10 V ranges; 15 pF, 30 to 300 V ranges	2 megohms; shunted by approx. 50 pF; 0.001 to 0.03 V ranges; 25 pF, 0.1 to 300 V ranges	same as 403B
Maximum input	600 V peak, 0.3 V and higher ranges; 25 V rms on 0.1 V and lower ranges	600 V peak, 0.3 to 300 V range; 25 V rms, 60 V peak, 0.001 to 0.1 V ranges	same as 403B
Power	5 standard radio-type mercury cells, battery life approx. 400 hours	4 rechargeable batteries, 40 hours' operation per recharge, up to 500 recharging cycles; self-contained recharging circuit functions during operation from ac line	same as 403B
Dimensions	8 $\frac{1}{4}$ " wide, 5 $\frac{1}{2}$ " high, 6 $\frac{3}{8}$ " deep (210 x 140 x 162 mm)	5 $\frac{1}{8}$ " wide, 6-3/32" high, 8" deep (130 x 160 x 203 mm)	same as 403B
Weight	net 4 $\frac{3}{4}$ lbs (2.1 kg); shipping 7 lbs (3.2 kg)	net 6 $\frac{1}{2}$ lbs (2.9 kg); shipping 10 lbs (4.5 kg)	same as 403B
Price	\$275	\$310	\$335

\*Use 10001A 10:1 Divider and 10111A Adapter to retain  $\pm 5\%$  ( $\pm 0.4$  dB) accuracy while measuring up to 425 V rms at 1 to 2 MHz.

#### For all models:

Range: 0.001 to 300 V rms full scale, 12 ranges.

Meter: responds to average value of input waveform, calibrated in the rms value of a sine wave.

# VOLTAGE, CURRENT, RESISTANCE



## RMS VOLTMETER

Fast, accurate true rms measurements  
Model 3400A

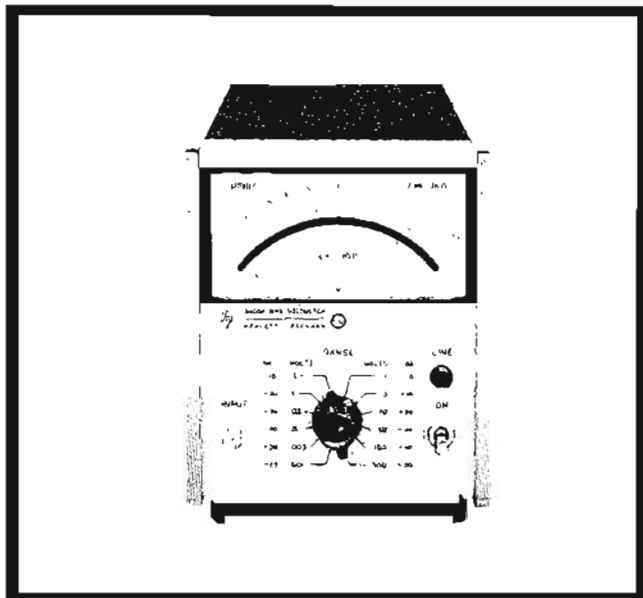

### Description

#### Fast, accurate rms measurements

HP Model 3400A RMS Voltmeter is a rugged precision instrument which measures the actual root-mean-square value of ac voltages which are between 100  $\mu$ V and 300 V rms and in the frequency range 10 Hz to 10 MHz. These voltages may be sinusoidal or nonsinusoidal and have crest factors (ratio of peak to rms) as high as 10 at full-scale deflection and as high as 100 at 10% of full-scale deflection. The ability of the HP 3400A to accept waveforms having such large crest factors insures that your measurements will be accurate, even when measuring nonsinusoidal waveforms, such as noise and pulse trains, without the need for correction factors. Model 3400A withstands overloads of 30 dB (or 800 V peak, whichever is less) on each range. This reduces the possibility of damage to the instrument, and protective circuitry prevents thermocouple burnout.

Model 3400A is extremely simple to operate because it requires no zero-set control and voltages are read from a linear voltage scale or in dBm. The voltmeter's 10 megohm input resistance minimizes circuit loading.

### Versatility

Model 3400A supplies a dc voltage from a rear panel connector that is proportional to the rms value of the input signal. Because of the high stability and linearity of this dc signal, it may be used to drive accessory equipment such as X-Y and strip-chart recorders for permanent records and plots, or to drive a digital voltmeter such as the HP Model 3440A for high-resolution measurements.

You can also measure the rms value of an ac current merely by using the HP Model 456A Current Probe. The jaws of the 456A, which sample the magnetic field about a conductor, are simply clamped around the conductor without breaking the circuit and do not disturb the measured circuit. Model 456A produces a 1 mV output for a 1 mA input; consequently the 3400A's scales may be read directly without scale conversion.

### Specifications

**Range:** 12 full scale ranges from 1 mV to 300 V in a 1, 3, 10 sequence. -72 to +52 dBm. (Usable indications to 100  $\mu$ V.)

**Meter scales: voltages:** 0.1 to 1 and 0.3 to 3.2. Decibel, -12 to +2 dBm (0 dBm = 1 mW, 600 ohms). Scales are individually calibrated to the meter movement.

**Frequency range:** 10 Hz to 10 MHz.

**Accuracy:** within  $\pm 1\%$  of full scale, 50 Hz to 1 MHz. Within  $\pm 2\%$  of full scale from 1 to 2 MHz. Within  $\pm 3\%$  of full scale, 2 to 3 MHz. Within  $\pm 5\%$  of full scale, from 10 to 50 Hz and from 3 to 10 MHz. (Usable readings to 5 Hz and 20 MHz.)

**Response:** responds to rms value (heating value) of the input signal for all waveforms.

**Crest factor:** (ratio of peak amplitude to rms amplitude): 10 to 1 at full scale (except where limited by maximum input) inversely proportional to pointer deflection, e.g., 20 to 1 at half-scale, 100 to 1 at tenth scale.

**Maximum input:** ac: 800 volts peak; dc: 600 volts.

**Input impedance:** from 0.001 V to 0.3 V range: 10 megohms shunted by 40 pF. From 1.0 V to 300 V range: 10 megohms shunted by 15 pF.

**Response time:** typically  $< 2$  sec. to within 1% of final value for an up-scale step change.

**Overload:** 30 dB or 800 volts peak, whichever is less, on each range.

**Output:** negative 1 V dc open circuit at full-scale deflection, proportional to pointer deflection. (From 10-100% of full scale.) 1 mA maximum nominal source impedance is 1000 ohms.

**Power:** 115 or 230 V  $\pm 10\%$ , 50 to 1000 Hz, approximately 7 watts.

**Dimensions:** 5 $\frac{1}{8}$  in. wide, 6 $\frac{1}{2}$  in. high, 11 in. deep (1/3 module). (130 x 165 x 279 mm.)

**Weight:** net: 7 $\frac{1}{4}$  lbs (3.3 kg); shipping: 10 lbs (4.5 kg).

**Accessories furnished:** 10110A Adapter, BNC to dual banana jack.

**Accessories available:** 11001A Cable, 45 in. long, male BNC to dual banana plug, \$5.50. 10503A Cable 4 ft. long, male BNC connectors, \$6.50. 11002A Test Lead, dual banana plug to alligator clips, \$7.50. 11003A Test Leads, dual banana plug to probe and alligator clip, \$10.

HP Model 456A AC Current Probe, 1 mV/1 mA, \$190.

### Options:

HP Model 3400A (Option 01) spreads out the dB scale by making it the top scale of the meter. \$25 extra.

**Price:** HP 3400A, \$525

## RF MILLIVOLTMETER

Measurement, 3 mV to 10V, 500 kHz to 1000 MHz  
Model 411A



VOLTAGE, CURRENT,  
RESISTANCE

### Description

Two linear voltage scales in a 1:3 ratio and millivolt sensitivity up to 1 GHz set the HP Model 411A RF Millivoltmeter apart from previous rf voltmeters. Its temperature-compensated probe results in low drift, even on the most sensitive range, so that you can measure millivolts of rf energy conveniently and with confidence. Model 411A simplifies your measurements of voltage from 0.5 to 1000 MHz.

Full-scale sensitivity from 10 millivolts full scale to 10 volts full scale is selected in seven 10-dB steps, so that most measurements may be made in the upper two-thirds of the scale for greater accuracy. Further, you can read dB directly from  $-42$  to  $+33$  for convenient gain measurements. Accessory probe tips suit it for measurements in many different kinds of circuits.

Further, an output is provided for galvanometer recording. Five probe tips have been designed for use with the 411A, ranging from the BNC open circuit probe tip, furnished with the instrument, to a pen-size probe having retractile alligator jaws for probing conveniently into restricted areas. The probe tips, available individually, are offered along with a spare diode cartridge as a complete set in a compact kit; it provides an immediate and versatile selection to meet all measurement requirements normally encountered.

### Specifications

**Voltage range:** 10 mV rms full scale to 10 V rms full scale in 7 ranges; full-scale readings of 0.01, 0.03, 0.1, 0.3, 1, 3 and 10 V rms.

**Frequency range:** 500 kHz to 1 GHz with accessory probe tips; usable indications to 4 GHz.

**Accuracy:** 500 kHz to 50 MHz,  $\pm 3\%$  of full scale; 50 MHz to 150 MHz,  $\pm 6\%$  of full scale; 150 MHz to 1 GHz,  $\pm 1$  dB (using appropriate probe tips).

**Meter scales:** two linear voltage scales, 0 to 1 and 0 to 3, calibrated in the rms value of a sine wave; dB scale, calibrated from  $+3$  to  $-12$  dB;  $0$  dB = 1 mW in 50 ohms.

**Input resistance:** depends on probe tip, frequency and input voltage; typically 200 k ohms at 1 MHz and 1 V rms. (For specific information contact your local Hewlett-Packard sales office).

**Probe tip furnished:** 11025A BNC Open Circuit Probe Tip, 500 kHz to 500 MHz; shunt capacity, less than 5 pF; maximum input, 200 V dc and 30 V ac p-p; input resistance at 10 MHz, typically 80 k ohms.

**Accessories available at additional cost:**

Probe tips

11022A Pen Type Probe Tip, 500 kHz to 50 MHz; shunt capacity, less than 5 pF; maximum input, 200 V dc and 30 V ac p-p; input resistance at 10 MHz, typically 80 k ohms. \$25.

11023A VHF Probe Tip, 500 kHz to 250 MHz; shunt capacity, less than 2.5 pF; maximum input, 200 V dc and 30 V ac p-p; input resistance at 10 MHz, typically 80 k ohms. \$30.

11024A Type N "Tee" Probe Tip, 1 MHz to 1 GHz; swr is less than 1.15 when terminated in 50 ohms;

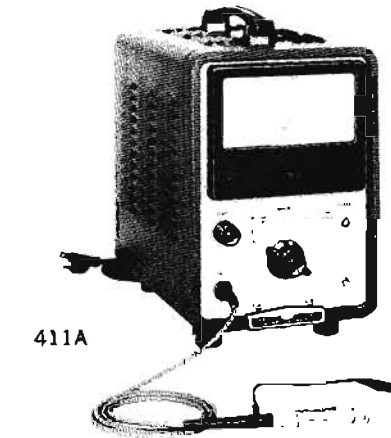

411A

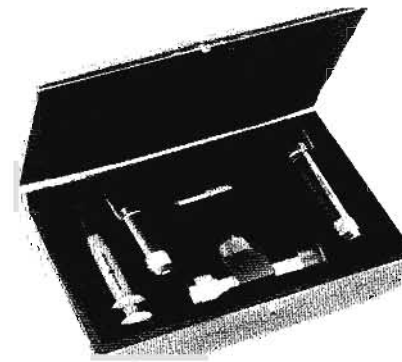

11027A

maximum input, 10 V dc and 30 V ac p-p to 250 MHz and 15 V ac p-p from 250 MHz to 1 GHz. \$40.  
11026A 100:1 Capacity Divider Probe Tip, 500 kHz to 250 MHz; division accuracy,  $\pm 1\%$ ; shunt capacity: 2 pF; maximum input:  $\pm 1000$  volts peak (dc + peak ac). \$35.

Probe kit: 11027A Accessory Probe Kit includes the 11022A, 11023A, 11024A, 11026A Probe Tips and a replacement diode cartridge, 5082-5004, in a convenient storage case. \$152.50.

50-ohm termination: 908A Coaxial Termination, \$35.

**Galvanometer recorder output:** proportional to meter deflection, 1 mA into 1000 ohms at full scale deflection.

**Power:** 115 or 230 volts  $\pm 10\%$ , 50 to 60 Hz, 35 watts.

**Dimensions:** cabinet:  $11\frac{3}{4}$ " high,  $7\frac{1}{2}$ " wide, 12" deep (298 x 191 x 305 mm). Rack mount:  $6\text{-}31/32$ " high, 19" wide,  $10\frac{3}{8}$ " deep behind panel (177 x 483 x 264 mm).

**Weight:** cabinet: net 12 lbs (5.4 kg), shipping 15 lbs (6.8 kg). Rack mount: net 15 lbs (6.8 kg), shipping 25 lbs (11.3 kg).

**Price:** HP 411A, \$450. HP 411AR, \$455.

## VOLTAGE, CURRENT, RESISTANCE



## SAMPLING VOLTMETER

Absolute average readings of high freq. signals  
Model 3406A

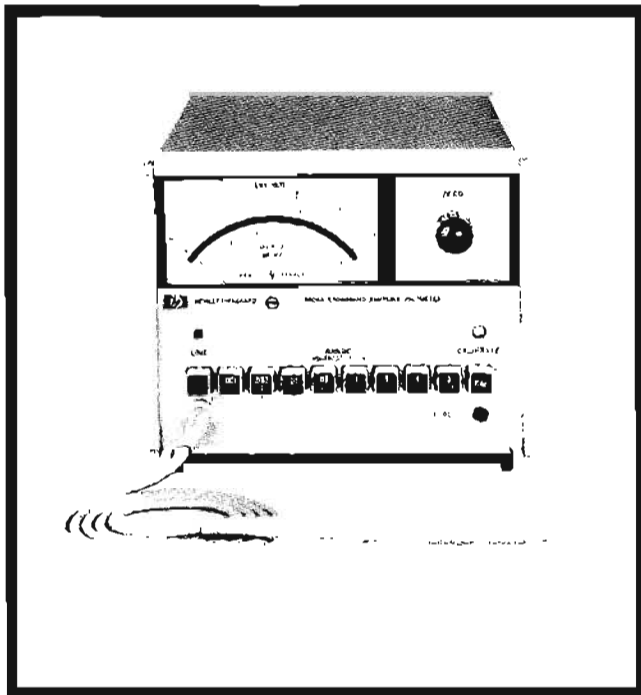

### Description

Absolute average readings (calibrated in rms of a sine wave) of high frequency signals previously impractical can now be made easily with the HP 3406A Sampling Voltmeter. Employing incoherent sampling techniques, the HP 3406A has extremely wide bandwidth (4 kHz to 1.2 GHz) with high input impedance. Signals as small as  $50 \mu\text{V}$  can be resolved on the sampling voltmeter's linear scale. Full scale sensitivity from 1 mV to 3 V is selected in eight 10 dB steps and may be read directly from  $-62 \text{ dBm}$  to  $+23 \text{ dBm}$  for power measurements. Accessory probe tips make the HP 3406A suitable for voltage measurements in many applications such as receivers, amplifiers and coaxial transmission lines.

Measurement indications can be retained on the 3406A meter by depressing a push-button located on the pen-type probe. This feature is useful when measurements are made in awkward positions where the operator cannot observe the meter indication and probe placements at the same time. Other features include a dc recorder output and sample hold output for connection to oscilloscopes, and peak or true rms voltmeters if other than absolute average measurements are required.

### Retain measured indication

The HP 3406A has a pushbutton located on the pen-type probe to retain the meter indication when the probe is removed from the circuit. When the pushbutton is released the 3406A is made operational to make another measurement. This feature makes possible measurements in awkward positions, where it is difficult to place the probe in the circuit under test and at the same time read the meter.

### DC recorder output

A dc output is available at the rear panel which is proportional to the meter deflection. The output may be adjusted for any full scale value from 0 to 1.2 volts into a 1000 ohm load.

### Linear voltage scales

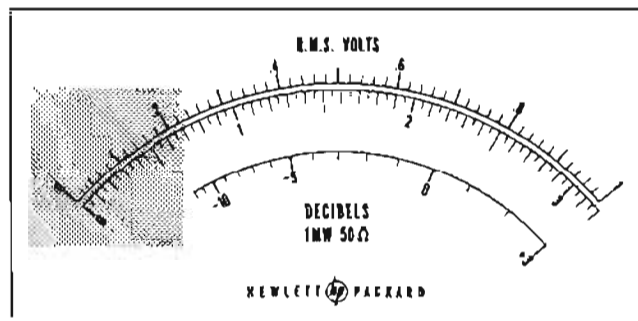

Two linear voltage scales display the eight ranges of sensitivity. The two scales calibrated from 0 to 1 and 0 to 3, permit convenient measurement in the upper two-thirds of the scale and the convenience of 10 dB separation. A calibrated dB scale is also provided. Voltage measurements of  $< 50 \mu\text{V}$  may easily be read on the linear meter scale. (Note shaded area on the meter scale shown above).

### Internal calibrator

A front panel calibrator permits calibration when accessories are used with the probe without the need for external standards. For zero adjustments, when the calibrate push-button is not engaged, the pencil probe is automatically shorted when inserted in the front panel calibrate receptacle.

### Fast recovery from overloads

The HP 3406A responds rapidly from overload. Overloads of 1000:1 on the 1 mV range to 10:1 on the 3 V range will not damage the instrument.

### Sample hold output

Peak or true rms measurements from  $< 10 \text{ kHz}$  to  $> 1 \text{ GHz}$  may be obtained by connecting a peak or true rms reading instrument to the sample hold output connection on the rear of the 3406A. The HP 3406A will indicate the absolute average value of the input signal calibrated in rms of a sine wave. If an oscilloscope is connected to the sample hold output, peak measurements can be made. Likewise, true rms measurements can be obtained by using an HP 3400A. Other applications may include statistical descriptions (amplitude density function) of input ac waveforms by performing a pulse height analysis of the sample hold output. The envelope of amplitude modulated carriers ( $< 1 \text{ kHz}$  for good resolution) can also be recovered directly at the sample hold terminals.

The ability of the sampling voltmeter to accept waveforms having large crest factors insures accuracy when measuring nonsinusoidal voltage.

## Specifications

**Voltage range:** 1 mV to 3 V full scale in 8 ranges; decibels from -50 to +20 dBm (0 dBm = 1 mW into 50 $\Omega$ ); absolute average-reading instrument calibrated to rms value of sine wave.

**Frequency range:** 10 kHz to 1 GHz; useful sensitivity from 1 kHz to beyond 2 GHz.

**Full-scale accuracy with calibrator:**  $\pm 3\%$ , 100 kHz—100 MHz;  $\pm 5\%$ , 25 kHz—700 MHz;  $\pm 8\%$ , 10 kHz—1 GHz;  $\pm 1$  dB, 4 kHz—1.2 GHz.

**Input impedance:** 100,000 ohms at 100 kHz. Capacity approx. 2 pF. Input capacity and resistance will depend upon accessory tip used (approx. 8 pF with 11072A isolator tip supplied).

### Sample Hold Output

Provides ac signal whose unclamped portion has statistics that are narrowly distributed about the statistics of the input, inverted in sign (operating into  $>200$  k $\Omega$  load with  $<1000$  pF).

**Noise:** typically 175  $\mu$ V rms.

**Accuracy with calibrator:** 0.01 V range and above: same as full scale accuracy of instrument.

**0.001 V to 0.003 V range:** value of input signal can be computed by taking into account the residual noise of the instrument.

**Jitter:** typically  $\pm 2\%$  peak of reading (with HP 3400A True RMS Voltmeter).

**Crest factor:** 0.001 V to 0.3 V, 20 dB; 1 V, 13 dB; 3 V, 3 dB.

**Meter scales:** linear voltage, 0 to 1 and 0 to 3; decibel, -12 to +3. Individually calibrated taut-band meter.

**Response time:** indicates within specified accuracy in  $<3$  sec.

**Jitter:**  $\pm 1\%$  peak (of reading).

### General

**DC recorder output:** adjustable from 0 to 1.2 mA into 1000 ohms at full scale, proportional to meter deflection.

**Overload recovery time:** meter indicates within specified accuracy in  $<5$  sec (30 V p-p max.).

**Maximum input:**  $\pm 100$  V dc, 30 V p-p.

**Temperature range:** instrument, 0°C to +55°C; probe, +10°C to +40°C.

**Power:** 115 or V  $\pm 10\%$ , 50 Hz to 1000 Hz, approximately 17 watts.

**Dimensions:** 8 $\frac{7}{8}$ " wide, 6 $\frac{1}{2}$ " high, 11 $\frac{1}{2}$ " deep (225 x 165 x 292 mm);  $\frac{1}{2}$  module.

**Weight:** net 12 lbs (5.4 kg); shipping 14 lbs (6.4 kg).

**Price:** HP 3406A, \$650.

**Accessories furnished:** 11072A isolator tip. Eliminates the effect of source impedance variations when the 11063A "T" is not used. 8710-0084 nut driver for tip replacement. 5020-0457 replacement tips; 10213-62102 ground clips.

**Accessories available:** a complete line of available accessories provides an immediate and versatile selection to meet all measurements normally encountered.

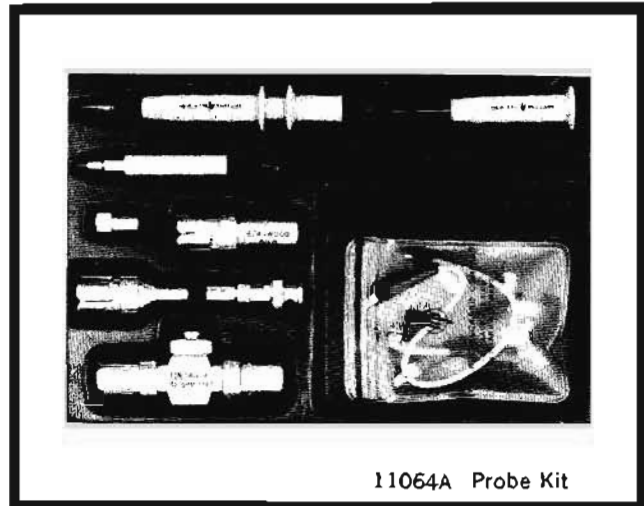

11064A Probe Kit

**11064A basic probe kit:** consists of the following: 11063A 50-ohm "T"; 11061A 10:1 divider tip; 10218A BNC adapter; (0950-0090) 50-ohm termination; 10213-62102 ground clips (2 ea.); 5020-0457 probe tips (5 ea.); 5060-4991 ground leads (2 ea.). Price: HP 11064A, \$100.

**11071A probe kit:** consists of all the above plus: 11073A pen type probe (with 11073-62101 ground lead); 10219A type 874A adapter; 10220A microdot adapter; 5060-0417 pincer jaw; 5060-0418 pin tip; 5060-0419 hook tip; 5060-0420 spring tip; 1251-0013 banana tip. Price: HP 11071A, \$185.

**11061A 10:1 divider:** as well as dividing the input voltage by a factor of ten, this accessory eliminates the effects of source impedance variations. Accuracy (divider alone):  $\pm 5\%$ , 1 kHz to 400 kHz;  $\pm 12\%$ , 400 MHz to 1 GHz. Max. input: 150 V p-p ac; 600 V dc. Price: HP 11061A, \$35.

**11063A "T":** should be used whenever measurements are made in 50-ohm systems. VSWR:  $<1.15$  at 1 GHz (bare probe in tee). Useful to about 1.5 GHz. Insertion power loss:  $<4\%$  up to 1 GHz. Price: HP 11063A, \$55.

**11072A isolator:** essentially eliminates effects of source impedance variations. Increases probe capacitance by approximately 6.5 pF. Recommended frequency range is 10 kHz to 250 MHz. (Furnished with instrument.) Price: HP 11072A, \$15.

**11073A pen-type isolator:** recommended frequency range is 10 kHz to 50 MHz. Various accessories adapt the 11073A to alligator jaws and other tips which facilitate point-to-point measurements (increases probe capacitance by approx. 7 pF). Price: HP 11073A, \$45.

**10218A probe-to-male BNC adapter:** recommended frequency range is 10 kHz to 250 MHz. Price: HP 10218A, \$6.



**VOLTAGE, CURRENT,  
RESISTANCE**



## MULTIFUNCTION VOLTMETERS

Models 410C, 410B

### ELECTRONIC VOLTMETER

Zero drift multi-function meter

Model 410C



#### Description

The HP Model 410C is an extremely versatile general-purpose instrument for use anywhere electrical measurements are made. This one instrument measures: dc voltages from 15 mV to 1500 volts, direct current from 1.5 nanoamps to 150 mA, and resistance from 0.2 ohm to 500 megohms. With a standard plug-in-probe, ac voltages at 20 Hz to 700 MHz from 50 mV to 300 volts and comparative indications to 3 GHz are attainable.

These measurements are made with laboratory precision previously not available in a single instrument. The versatile easy-to-use HP 410C will be valuable in any laboratory, production line, or service department.

#### Specifications

##### DC voltmeter

**Voltage ranges:**  $\pm 15$  mV to  $\pm 1500$  V full scale in 15, 50 sequence (11 ranges).

**Accuracy:**  $\pm 2\%$  of full scale on any range.

**Input resistance:** 100 megohms  $\pm 1\%$  on 500 mV range and above.

10 megohms  $\pm 3\%$  on 15 mV, 50 mV, and 150 mV ranges.

##### DC ammeter

**Current ranges:**  $\pm 1.5$   $\mu$ A to  $\pm 150$  mA full scale in 1.5, 5 sequence (11 ranges).

**Accuracy:**  $\pm 3\%$  of full scale on any range.

**Input resistance:** decreasing from 9 k ohms on 1.5  $\mu$ A scale to approximately 0.3  $\Omega$  on the 150 mA scale.

**Special current ranges:**  $\pm 1.5$ ,  $\pm 5$  and  $\pm 15$  nanoamps may be measured on the 15, 50, and 150 millivolt ranges using the voltmeter probe, with  $\pm 5\%$  accuracy and 10 megohm input resistance.

##### Ohmmeter

**Resistance range:** resistance from 10 ohms to 10 megohms center scale (7 ranges).

**Accuracy:** zero to midscale:  $\pm 5\%$  of reading or  $\pm 2\%$  of midscale, whichever is greater.

$\pm 7\%$  of midscale to scale value of 2.

$\pm 8\%$  from scale value of 2 to 3.

$\pm 9\%$  from scale value of 3 to 5.

$\pm 10\%$  from scale value of 5 to 10.

##### Amplifier

**Voltage gain:** 100 maximum.

**AC rejection:** 3 dB at  $1/2$  Hz; approximately 66 dB at 50 Hz and higher frequencies for signals less than 1600 V peak or 30 times full scale, whichever is smaller.

**Isolation:** impedance between common and chassis is  $> 10$  meg in parallel with 0.1  $\mu$ F. Common may be floated up to 400 V dc above chassis for dc and resistance measurements.

**Output:** proportional to meter indication; 1.5 V dc at full scale, maximum current, 1 mA.

**Output impedance:** less than 3 ohms at dc.

**Noise:** less than 0.5% of full scale on any range (p-p).

**DC drift:** less than 0.5% of full scale/year at constant temperature. Less than 0.02% of full scale/ $^{\circ}$ C.

**Overload recovery:** recover from 100:1 overload in  $< 3$  sec.

##### AC voltmeter

**Ranges:** 0.5 V full scale to 300 V in 0.5, 1.5, 5 sequence (7 ranges).

**Accuracy:**  $\pm 3\%$  of full scale at 400 Hz for sinusoidal voltages from 0.5 to 300 V rms. The ac probe responds to the positive peak-above-average value of the applied signal.

**Frequency response:**  $\pm 2\%$  from 100 Hz to 100 MHz (400 Hz ref.)  $\pm 10\%$  from 20 Hz to 100 Hz and from 100 MHz to 700 MHz.

**Frequency range:** 20 Hz to 700 MHz.

**Input impedance:** input capacity 1.5 pF, input resistance >10 megohms at low frequencies. At high frequencies impedance drops off due to dielectric loss.

**Safety:** the probe body is grounded to chassis at all times for safety. All ac measurements are referenced to chassis ground.

**Meter:** individually calibrated taut-band meter. Responds to positive peak-above-average. Calibrated in rms volts for sine wave input.

#### General

**Maximum Input:** (see Overload Recovery) DC: 100 V on 15, 50, and 150 mV ranges; 500 V on 0.5 to 15 V

ranges; 1600 V on higher ranges. AC: 100 times full scale or 450 V peak, whichever is less.

**Power:** 115 or 230 V  $\pm 10\%$ . 50 to 1000 Hz, 13 watts (20 watts with 11036A AC Probe).

**Dimensions:** 6 $\frac{1}{2}$ " high, 5 $\frac{1}{8}$ " wide, 11" deep (165 x 130,2 x 320,7 mm) behind panel. Fits 5060-0797 Rack Adapter and 1050 Series combining cases.

**Weight:** net 8 lbs (4,0 kg); shipping approx. 12 lbs (5,44 kg).

**Accessories furnished:** detachable power cord, NEMA plug.

**Option 02:** HP Model 410C less AC Probe.

**Price:** HP 410C, \$425; Option 02, \$375.

## VACUUM TUBE VOLTMETER

### All-purpose instrument measures to 700 MHz

#### Model 410B

#### Specifications

##### AC voltmeter

**Range:** 1 to 300 V full scale, 6 ranges.

**Frequency range:** 20 Hz to 700 MHz.

**Frequency response:** flat within  $\pm 1$  dB to 700 MHz, drops off less than 1 dB at 20 Hz; indications obtainable to 3000 MHz.

**Input impedance:** input capacity 1.5 pF, input resistance 10 megohms at low frequencies; at high frequencies resistance drops off due to dielectric loss.

##### DC voltmeter

**Range:** 1 to 1000 V full scale.

**Input resistance:** approx. 122 megohms, all ranges.

##### Ohmmeter

**Range:** 0.2 ohm to 500 megohms in 7 ranges; midscale readings of 10, 100, 1000, 10,000, 100,000 ohms, and 1 and 10 megohms.

**Accuracy:**  $\pm 1\Omega$  at midscale on Rx1; others  $\pm 5\%$  at mid-scale.

##### General

**Accuracy:**  $\pm 3\%$  of full scale, all ranges, on sinusoidal ac voltages and dc voltages; ac portion of instrument is peak-responding, calibrated in rms volts.

**Power:** 115 or 230 V  $\pm 10\%$ , 50 to 1000 Hz, 40 W.

**Dimensions:** cabinet, 7 $\frac{3}{8}$ " wide, 11 $\frac{1}{2}$ " high, 8 $\frac{3}{4}$ " deep (187 x 292 x 223 mm); rack mount, 19" wide, 6 $\frac{3}{4}$ " high, 6" deep behind panel (483 x 172 x 152 mm).

**Weight:** net 12 lbs (5,4 kg); shipping 13 lbs (5,9 kg) (cabinet); net 12 lbs (5,4 kg); shipping 19 lbs (8,6 kg) (rack mount).

**Accessories available:** 11039A Capacitive Voltage Divider, 25 kV max., \$150, requires 11018A Adapter, \$35; 11040A Capacitive Voltage Divider, 2 kV max., \$35; 11042A Probe Coax T Connector for Type "N" systems, \$50; 11043A Probe Coax N Connector adapts to Type "N" systems, \$37.50; 11044A DC Divider, 30 kV max., \$50.

**Price:** HP 410B, \$245 (cabinet). HP 410BR, \$265 (rack mount).



#### Description

Because of the large number of tasks it will perform, the 410B Vacuum Tube Voltmeter can play a uniquely valuable role in any laboratory, broadcast station or production test department. It combines in one instrument an ac voltmeter covering the frequency range from audio to radar frequencies, a dc voltmeter with 100 megohms input impedance, and an ohmmeter capable of measuring resistance, 0.2 ohm to 500 megohms. It is easy to use, compact, and lightweight.

# VOLTAGE, CURRENT, RESISTANCE



## MULTI-FUNCTION METER

Low-cost, solid state, battery operated

Model 427A

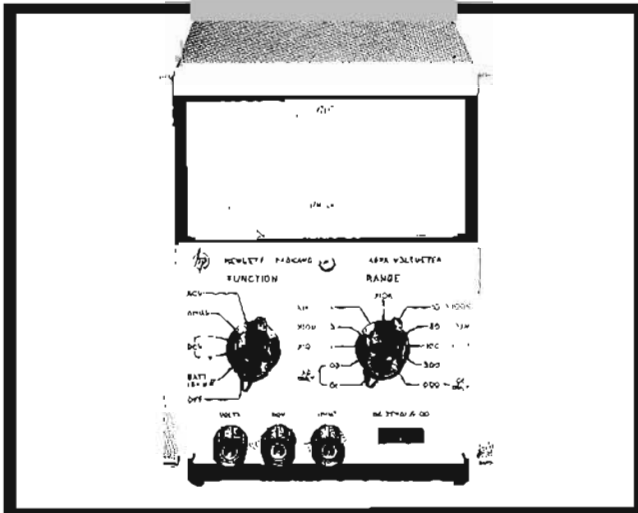

### Features:

- Multiple function
- Ten ranges of ac voltage measurements
- Nine ranges of dc voltage measurements
- Seven ranges of ohms measurements
- 10 megohm input impedance
- Floating input
- All solid state
- Battery operation
- AC line and battery operation with Option 01
- Taut band meter individually calibrated

### Description

The new all solid-state Hewlett-Packard 427A Voltmeter offers a broad measuring capability at moderate cost. This instrument measures: dc voltages from 100 mV full scale to 1 kV full scale, ac voltage from 10 mV full scale to 300 V full scale, and resistance from 10 ohms center scale to 10 megohms center scale. A dBm scale is included and is calibrated so that 0 dBm is 1 mW into 600 ohms.

This versatile HP 427A will be valuable in any laboratory, production line, service department, or in the field. Operation is from one internal battery, a 22 $\frac{1}{2}$  volt dry cell, which provides more than 300 continuous hours of typical operation. AC line and battery operation is available as an option.

Low zero drift and maintenance of calibration of the circuit are retained when making measurements so that only an occasional adjustment of the zero control is needed.

### Specifications DC Voltmeter

**Voltage ranges:**  $\pm 100$  mV to  $\pm 1000$  V full scale in a 1, 3, 10 sequence (9 ranges).

**Accuracy:**  $\pm 2\%$  of full scale on any range ( $0^\circ\text{C}$  to  $50^\circ\text{C}$ ).

**Input resistance:** 10 megohms on all ranges.

**AC rejection:** superimposed peak ac voltages 100 times greater than full scale affects reading less than 1% for 60 Hz and above. 450 volts peak maximum.

**Overload:** 1200 V dc on any range.

### AC Voltmeter

**Voltage ranges:** 10 mV to 300 V rms full scale in a 1, 3, 10 sequence (10 ranges).

**Frequency range:** 10 Hz to 1 MHz.

**Accuracy:** ( $0^\circ\text{C}$  to  $50^\circ\text{C}$ ).

Range	= 2% of full scale
.01 V-30 V	10 Hz-1 MHz
100 V-300 V	10 Hz-100 kHz

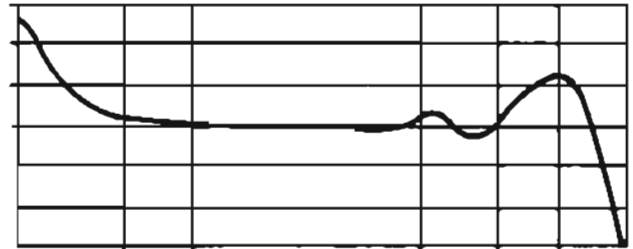

### Ohmmeter

**Resistance ranges:** 10 ohms center scale to 10 megohms center scale (7 ranges).

**Accuracy:**  $\pm 5\%$  of reading at midscale ( $0^\circ\text{C}$  to  $+50^\circ\text{C}$ ).

Range	Open Circuit Voltage	Short Circuit Current
X 10	0.1 V	10 mA
X 100	0.1 V	1 mA
X 1 k	1 V	1 mA
X 10 k	1 V	100 $\mu\text{A}$
X 100 k	1 V	10 $\mu\text{A}$
X 1 M	1 V	1 $\mu\text{A}$
X 10 M	1 V	0.1 $\mu\text{A}$

### General

**Floating input:** may be operated up to 500 V dc above ground. (Ohms input open in any function except ohms—volts input open when instrument is in off position).

**Power:** 22 $\frac{1}{2}$  volt dry cell battery. (non-rechargeable Eveready No. 763 or RCA VS102).

Option 01: battery operation and ac line operation (selectable on rear panel). 115 or 230 V  $\pm 20\%$ , 50 Hz to 1000 Hz,  $\frac{1}{2}$  W.

**Weight:** net, 5 $\frac{1}{4}$  lbs (2,36 kg); shipping: 7 lbs (3,2 kg).

**Dimensions:** 5 $\frac{1}{8}$ " wide, 6-3/32" high, 8" deep (130,2 x 154,8 x 203,2 mm).

**Price:** HP 427A, \$195, HP 427A Option 01, \$230.

# AUTOVOLTMETER

Automatic voltage and resistance measurements  
Model 414A



**VOLTAGE, CURRENT,  
RESISTANCE**

## Features:

- Measure 5 mV f.s. to 1500 Vdc f.s. linear volts/ohms scale
- Select voltage or resistance . . . ranging automatic

## Description

A new 12-range all solid-state dc volt-ohmmeter from Hewlett-Packard gives accurate measurements immediately with automatic range selection. Operation is simply touch and read. The Model 414A Autovoltmeter selects correct range and polarity less than 300 milliseconds after contact is made, displaying both range and polarity in illuminated characters.

DC voltages can be measured at sensitivities from 5 millivolts to 1500 volts full scale. Accuracy is  $\pm$  (0.5% of reading + 0.5% of full scale) on the mirror backed, individually calibrated taut-band meter. Input resistance is 10 megohms on the 5 mV and 15 mV range increasing to 100 megohms on the 50 millivolt range and above.

Resistance is presented on linear scale with full-scale ranges from 5 ohms to 1.5 megohms which are automatically identified on the panel. Current through the unknown is 1 milliampere up to 5 k ohms, 1 microampere above 5 k ohms. Accuracy is  $\pm$  (1% of reading + 0.5% of full scale) on all ranges.

The HP Model 414A was designed to serve bench and production operations where measurements over a wide range are taken in rapid succession. It offers speed and convenient analog analysis at low cost.

## Auto-ranging

Range changing decisions are based on two preset signal levels; one near full scale deflection, and the other near  $\frac{1}{4}$  full scale. An amplitude comparator produces an "up" range signal whenever the input voltage tends to rise above the level which is near full scale, and a "down" range signal whenever the input voltage tends to fall below the level near  $\frac{1}{4}$  full scale.

Range switching and indication logic consists of a set of four solid state multivibrators which define the twelve ranges of the instrument. The ohmmeter function employs a feedback-stabilized current source which allows the use of a linear ohms scale and avoids a special meter scale for resistance measurements. The resulting meter scales are easy to read.

## Specifications

### DC voltmeter

- Voltage range:**  $\pm$ 5 millivolts to  $\pm$ 1500 V full scale in twelve ranges. (Manual or auto-ranging.)
- Accuracy:**  $\pm$  (0.5% of reading + 0.5% of full scale).
- Input resistance:** 100 megohms on 50 mV range and above. 10 megohms on 5 and 15 mV ranges.
- Superimposed ac rejection:** in manual mode, insensitive to 60 Hz signal with peak value less than 7 times full scale dc level of range in use. In auto mode, insensitive



to 60 Hz signal with peak value less than 20% of dc being measured.

### Ohmmeter (Linear scale)

- Resistance range:** 5 ohms to 1.5 megohms in 12 ranges (manual or auto-ranging with linear scale).
- Accuracy:**  $\pm$  (1% of reading + 0.5% of full scale).
- Source current:** up to 5 k ohms 1 mA; above 5 k ohms 1  $\mu$ A.

### General

- Automatic range selection:** automatically selects correct voltage and resistance range in less than 300 milliseconds.
- Manual range selection:** down-ranges one range each time down range button is pressed. Starts over at 1500 volts from 5 mV range.
- Polarity selection:** automatic in either manual or auto mode.
- Meter:** individually calibrated taut-band meter with mirror scale. Linear scales 0 to 5 and 0 to 15.
- Isolation resistance:** at least 100 megohms shunted by 0.1  $\mu$ F between common terminal and case (power line ground).
- Floating input:** may be operated up to 500 Vdc above ground.
- Power:** 115 or 230 volts  $\pm$ 10%, 50 to 1000 Hz. Approx. 18 watts.
- Dimensions:** ( $\frac{1}{2}$  module), 6-18/32" high, 7-25/32" wide, 12" deep (167 x 197 x 305 mm).
- Weight:** net: 10 $\frac{1}{4}$  lbs (4,6 kg); shipping: 13 lbs (6,4 kg).
- Price:** HP 414A, \$650.

## VOLTAGE, CURRENT, RESISTANCE



## DC VOLT-OHM-AMMETER

1% accuracy vtvm is also ohmmeter, ammeter  
Model 412A

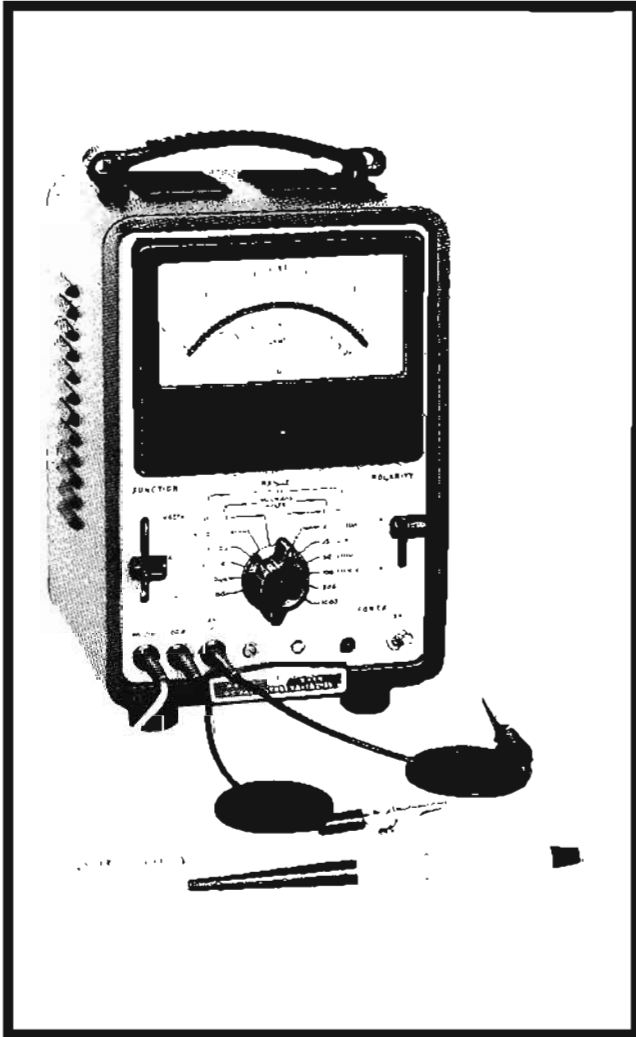

### Description

The HP Model 412A is a multipurpose meter designed to measure dc voltage, current, and resistance with laboratory accuracy and yet be of great utility in production-line test-bench work. Simplicity of operation and low cost permit its use wherever dc measurements are made.

Model 412A may also be used as a stable 60 dB amplifier which has an output proportional to meter indication.

There are only three controls; a lever-type function selector, a 13-position range switch, and a lever-type polarity switch. The extreme stability of the 412A makes it easier to use by eliminating the need for constantly re-zeroing the meter. The stability of the HP 412A is such that the usual front-panel, zero-set control has been eliminated.

The precision six-inch meter has two scales used for both voltage and current and a third scale which is calibrated in ohms. Further, the meter face has a mirror back for greatest accuracy in reading.

### Features:

- Versatile, measures voltage, resistance, current
- Floating input
- High input resistance
- Use as a 60 dB amplifier
- Individually calibrated meter eliminates tracking error

### Specifications

#### Voltmeter

**Voltage range:** pos. and neg. voltages from 1 mV to 1000 V full scale, 13 ranges.

**Accuracy:**  $\pm 1\%$  of full scale on any range.

**Input resistance:** 10 megohms  $\pm 1\%$  on 1 mV, 3 mV and 10 mV ranges; 30 megohms  $\pm 1\%$  on 30 mV range; 100 megohms  $\pm 1\%$  on 100 mV range; 200 megohms  $\pm 1\%$  on 300 mV range and above.

#### Ammeter

**Current range:** pos. and neg. currents from 1  $\mu$ A to 1 A full scale, 13 ranges.

**Accuracy:**  $\pm 2\%$  of full scale on any range.

**Input resistance:** decreasing from 1000 ohms on 1  $\mu$ A scale to 0.1 ohm on 1 A scale.

#### Ohmmeter

**Resistance range:** resistance from 1 ohm to 100 megohms center scale, 9 ranges.

**Accuracy:**  $\pm 5\%$  of reading, 0.2 ohm to 500 megohms;  $\pm 10\%$  of reading, 0.1 to 0.2 ohm and 500 megohms to 5000 megohms.

#### Amplifier

**Voltage gain:** 1000 maximum.

**DC bandwidth:** dc to 0.7 Hz on 100  $\mu$ V range and above.

**Output:** proportional to meter indication; 1 V at full scale; max. current, 1 mA (full scale corresponds to 1 on upper scale).

**Output Impedance:** less than 2 ohms at dc.

**Noise:** less than 2.0  $\mu$ V rms (typically less than 15  $\mu$ V p-p) referred to the input.

**Drift:** negligible.

### General

**Common mode rejection:** may be operated up to 500 V dc, or 130 V ac above ground.

**Power:** 115 or 230 volts  $\pm 10\%$ , 50 to 60 Hz, 35 watts.

**Dimensions:** cabinet: 11 $\frac{1}{2}$ " high, 7 $\frac{1}{2}$ " wide, 10" deep (292 x 191 x 254 mm); rack mount: 5-7/32" high, 19" wide, 7 $\frac{1}{2}$ " deep behind panel (134 x 483 x 191 mm).

**Weight:** net: 12 lbs (5,5 kg); shipping: 14 lbs (6,4 kg) (cabinet); net 12 lbs (5,5 kg); shipping: 20 lbs (9,1 kg) (rack mount).

**Price:** HP 412A, \$400 (cabinet).

HP 412AR, \$405 (rack mount).

## DC MICROVOLT-AMMETER

Portable with direct reading of 1 pA and 1  $\mu$ V  
Model 425A



**VOLTAGE, CURRENT,  
RESISTANCE**

### Description

Hewlett-Packard 425A DC Microvolt-Ammeter makes measurements of extremely small dc voltages and currents, even in the presence of relatively strong ac signals.

Since the 425A measures dc voltages from 1  $\mu$ V to 1 V and dc currents from 1 pA to 3 mA, it is an extremely useful tool in all branches of scientific measurement. For example, it can be used to study nerve potentials for the biologist and medical researcher, to study chemically generated emf, minute voltages in thermocouples and current in ionization chambers.

Since currents as small as 1 pA can be measured directly, the Model 425A is valuable for measuring vacuum tube grid currents and photomultiplier currents in ionization chambers. Thus, this meter has great utility in physics research, as well as in electronics. Further, its current and voltage sensitivity permit measurement of both extremely high and very low resistances.

Model 425A is provided with output terminals so that it may be used as a dc amplifier having 100 dB ( $10^5$ ) voltage gain. Output from the amplifier is 1 V for an end-scale deflection or 1 mA into approximately 1000 ohms, so that it will operate either a potentiometer or galvanometer recorder to make permanent records of measurements.

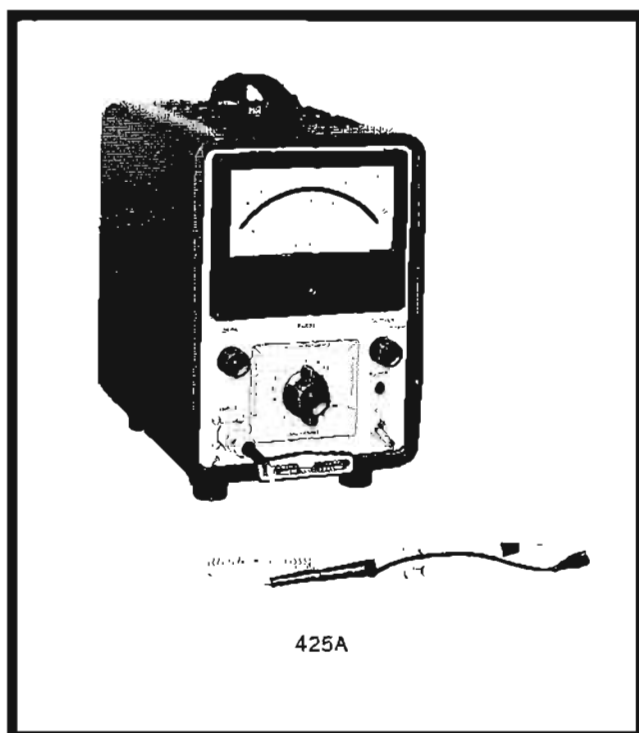

### Specifications

#### Microvolt-ammeter

**Voltage range:** pos. and neg. voltages from 10  $\mu$ V end scale to 1 V end scale, 11 steps, 1, 3, 10 sequence.

**Current range:** pos. and neg. currents from 10 pA end scale to 3 mA end scale, 18 steps, 1, 3, 10 sequence.

**Input impedance:** voltage ranges, 1 megohm  $\pm$  3%; current range, depends on range, 1 megohm to 0.33 ohm.

**Accuracy:** within  $\pm$  3% of end scale; line frequency variations  $\pm$  5 Hz affect accuracy less than  $\pm$  2%.

#### Amplifier

**Gain:** 100,000 maximum.

**AC rejection:** at least 3 dB at 1 Hz, 50 dB at 50 Hz and approximately 60 dB or more above 60 Hz; a power-line frequency or twice power-line frequency signal 40 dB greater than end scale causes less than 1% error.

**Output:** 0 to 1 V for end-scale reading, adjustable (5000-ohm shunt potentiometer), 1 mA maximum at 1 V output.

**Output impedance:** depends on setting of output potentiometer; 10 ohms when potentiometer is set for maximum output.

**Noise:** less than 0.2  $\mu$ V rms (typically less than 1.2  $\mu$ V p-p) referred to the input.

**Drift:** after 15 minutes' warm-up, drift is less than  $\pm$  4  $\mu$ V per day referred to input.

#### General

**Power:** 115 or 230 volts  $\pm$  10%, 60 Hz, 40 W; 50 Hz operation on special order.

**Dimensions:** cabinet: 7 $\frac{3}{8}$ " wide, 11 $\frac{3}{4}$ " high, 12" deep (187 x 299 x 305 mm); rack mount: 19" wide, 7" high, 11" deep behind panel (483 x 178 x 279 mm).

**Weight:** net 17 lbs (7,7 kg); shipping 18 lbs (8,2 kg) (cabinet); net 21 lbs (9,5 kg); shipping 29 lbs (13,2 kg) (rack mount).

**Accessories available:** 11021A 1000:1 Divider Probe, increases range of 425A to 1000 volts; division accuracy  $\pm$  2%, input resistance 10 megohms, \$55.

**Option 01:** for operation from 50 Hz power, no extra charge.

**Price:** HP 425A, \$500 (cabinet). HP 425AR, \$505 (rack mount).

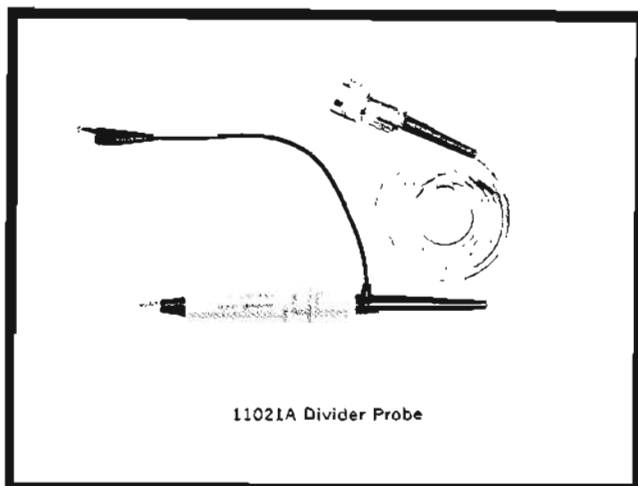

**VOLTAGE, CURRENT,  
RESISTANCE**



## CLIP-ON MILLIAMMETER

Measure without interrupting circuit; probes  
Model 428B

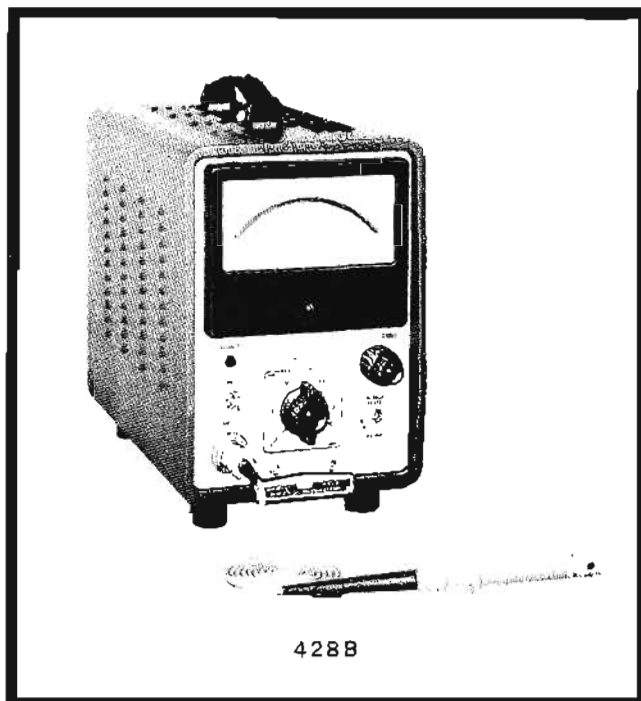

### Description

Direct current from .01 milliampere to 10 amps can be measured with the HP 428B without interrupting the circuits and without the error-producing loading of conventional methods.

For any measurement of dc within its range, simply clamp the jaws of the 428B around a wire and read.

This ease and speed of operation are unparalleled, especially for applications where many dc measurements must be made. Wide current range of the 428B will handle most signals directly. For even greater sensitivity, several loops may be put through the probe, increasing the sensitivity by the same factor as the number of loops.

In addition to making current measurements directly, the 428B is also valuable for measuring sums and differences of currents in separate wires. When the probe is clipped around two wires carrying current in the same direction, their sum is indicated on the meter; when one of the wires is reversed, their difference is measured. Thus, current balancing is possible by obtaining a zero difference reading.

Model 428B provides an output voltage proportional to the measured current which is useful for driving recorders or making low-frequency (dc to 400 Hz) current measurements.

### Specifications

**Current range:** 0.1 mA to 10 amperes; nine full-scale ranges from 1 mA to 10 amperes in a 1, 3, 10... sequence.

**Accuracy:**  $\pm 3\%$  of full scale,  $\pm 0.1$  mA, from  $0^\circ\text{C}$  to  $+55^\circ\text{C}$ .

**Probe inductance:** less than  $0.5 \mu\text{H}$ ; no noticeable loading, even up to 1 MHz.

**Probe induced voltage:** less than 15 mV peak (at 20 kHz and harmonics).

**Output:** approx. 1.5 V and 1 mA max. for full scale; 100-ohm source; variable linear output level with switch provision for calibrated 1 V (corresponds to full-scale deflection).

**Noise level:** less than  $\pm 0.015$  mA.

**AC rejection:** ac with peak value less than full scale affects meter accuracy less than 2% at frequencies different from the carrier (approx. 40 kHz) and its harmonics; the above instantaneous current must not exceed full scale below 5 Hz; on the 10 amp range, ac peak value is limited to 4 amps.

**Power:** 115 or 230 V  $\pm 10\%$ , 50 to 60 Hz, approx. 70 W.

**Operating temperature range:**  $-20^\circ\text{C}$  to  $+55^\circ\text{C}$ .

**Storage temperature:**  $-40^\circ\text{C}$  to  $+65^\circ\text{C}$ .

**Probe insulation:** 300 volts maximum.

**Probe tip size:** approximately  $\frac{1}{2}$ " by  $\frac{21}{32}$ ", aperture diameter  $\frac{5}{32}$ ".

**Dimensions:**  $7\frac{1}{2}$ " wide,  $11\frac{1}{2}$ " high,  $1\frac{1}{4}$ " deep (191 x 292 x 272 mm); rack mount: 19" wide,  $6\frac{31}{32}$ " high, 13" deep (483 x 177 x 330 mm).

**Weight:** net 19 lbs (8,6 kg), shipping 24 lbs (10,8 kg) (cabinet); net 24 lbs (10,8 kg), shipping 35 lbs (15,8 kg) (rack mount).

### Options:

01. HP 3528A Current Probe (aperture  $2\text{-}9/16$ ") in lieu of 428A-21A Probe normally supplied, add \$375.

02. HP 3529A Magnetometer Probe in lieu of 428A-21A Probe normally supplied, no extra charge.

**Price:** HP 428B, \$600. (cabinet)

HP 428BR, \$605. (rack mount)

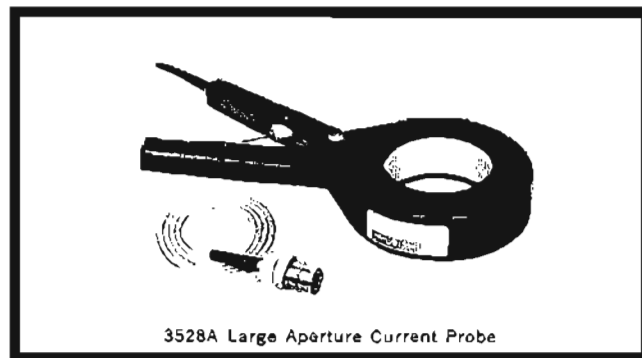

3528A Large Aperture Current Probe

This large aperture current probe permits the 428B to make measurements on any conductor up to  $2\text{-}9/16$ " in diameter. It is useful for measuring common-mode, ground and electrolysis currents in pipes, multi-conductor cables (including lead-sheathed), ground straps, and even microwave waveguide. Current range of this large diameter probe is the same as the 428B. The bandwidth is dc to 300 Hz. Accuracy is  $\pm 1$  mA  $\pm 3\%$  of full scale when the probe is calibrated with the instrument. Inductance less than  $3 \mu\text{H}$  is introduced into the measured circuit.

**Price:** HP 3528A, \$450.

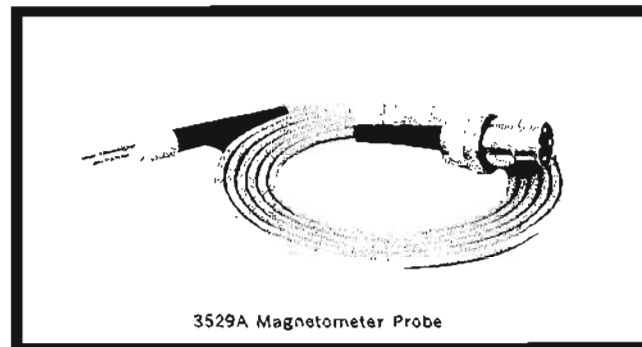

3529A Magnetometer Probe

The HP 3529A Magnetometer Probe is useful in applications where determination must be made of the direction or magnitude of a magnetic field. It is useful in applications ranging from acoustical transducer design to investigations involving the Zeeman effect. Conversion factor is 1:1, producing a reading on the 428B in milliamps which is directly equal to the measured field strength in milligauss. Range is 1 milligauss to 10 gauss with the 428B. The bandwidth is dc to 80 Hz, and accuracy is  $\pm 3\%$  of full scale when the probe is calibrated with the instrument.

**Price:** HP 3529A, \$75.



## VOLTMETER ACCESSORIES

Voltage dividers, current probe for VTVM's  
Model 456A, 11000 Series



**VOLTAGE, CURRENT,  
RESISTANCE**

### 456A AC Current Probe

Your conventional voltmeter or oscilloscope can measure current quickly and dependably — without direct connection to the circuit under test or any appreciable loading to the test circuit. The HP 456A AC Current Probe clamps around the current-carrying wire, and provides a voltage output you read on a voltmeter or scope. Model 456A's 1 mA to 1 mV conversion permits direct reading up to 1 ampere rms.

### Specifications, 456A

**Sensitivity:** 1 mV/mA  $\pm 1\%$  at 1 kHz.

**Frequency response:**  $\pm 2\%$ , 100 Hz to 3 MHz;  $\pm 5\%$ , 60 Hz to 4 MHz;  $-3$  dB at  $< 25$  Hz and greater than 20 MHz.

**Pulse response:** rise time is  $< 20$  nsec, sag  $< 16\%/msec$ .

**Maximum Input:** 1 amp rms, 1.5 amp peak; 100 mA above 5 MHz.

**Effect of dc current:** no appreciable effect on sensitivity and distortion from dc current up to 0.5 amp.

**Input Impedance:** (impedance added in series with measured wire by probe) less than 50 milliohms in series with 0.05  $\mu$ H (this is approximately the inductance of 1/2 in. of hookup wire).

**Probe aperture:** 5/32" (4 mm) diameter.

**Probe shunt capacity:** approx. 4 pF added from wire to ground.

**Distortion at 1 kHz:** for 0.5 amp input at least 50 dB down; for 10 mA input at least 70 dB down.

**Equivalent input noise:**  $< 50 \mu$ A rms (100  $\mu$ A when ac powered).

**Output Impedance:** 220 ohms at 1 kHz, approximately +1 V dc component; should work into load of not less than 100,000 ohms shunted by approximately 25 pF.

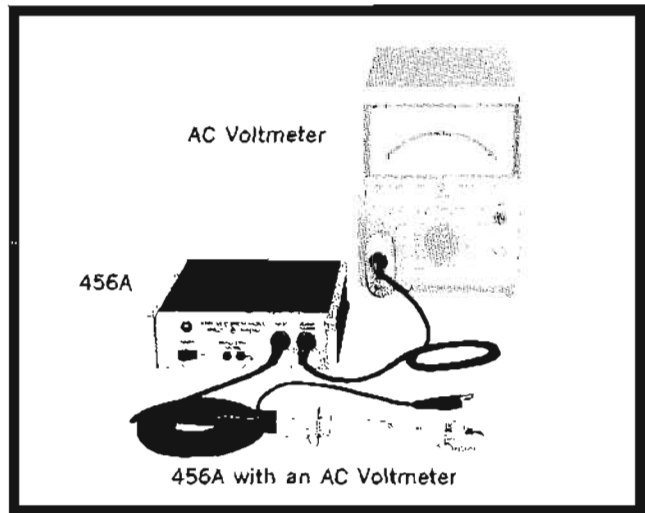

**Power:** two Mallory Battery Co. TR 233R and one TR 234 batteries (1420-0005 and 1420-0006); battery life approximately 400 hours; ac power supply optional at extra cost, 115 or 230 V  $\pm 10\%$  50 to 1000 Hz approx. 1 W.

**Weight:** net 3 lbs (1.4 kg); shipping 4 lbs (1.8 kg).

**Dimensions:** 5" wide, 6" deep, 1 1/2" high (127 x 152 x 38 mm); probe cable is 5 ft. long; 2 ft. output cable terminated with dual banana plug.

**Accessory available:** 456-11A AC Supply for field installation, \$40. 11028A 100:1 Current Divider, \$32.

**Price:** HP 456A with batteries, \$225.

**Option 01:** AC supply installed in lieu of batteries, add \$20.

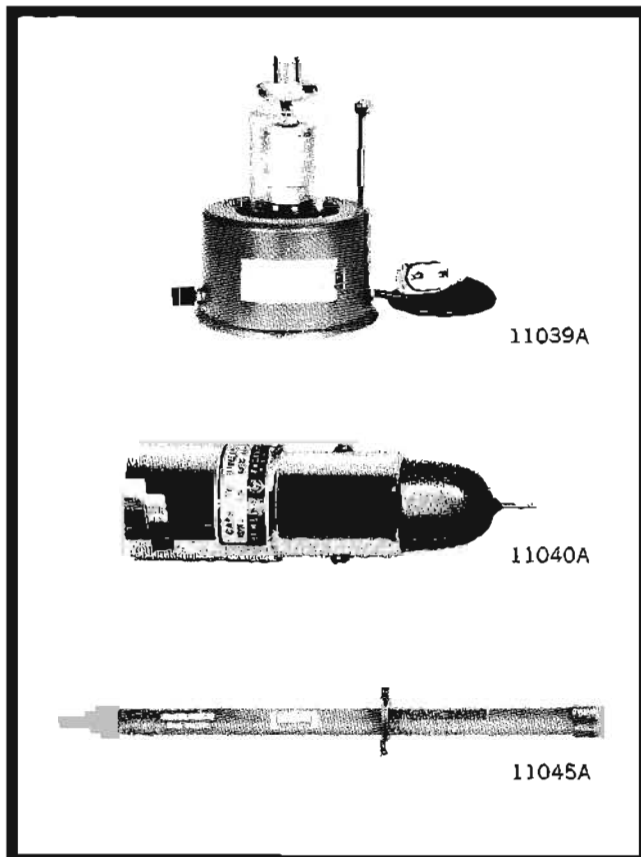

### 11039A capacitive voltage divider

For 400 and 410 series voltmeters. Safely measures power voltages to 25 kV; accuracy  $\pm 3\%$ . Division ratio, 1000:1. Input capacity, 15 pF  $\pm 1$ . Maximum voltage ratings (sea level) 60 Hz, 25 kV; 100 kHz, 22 kV; 1 MHz, 20 kV; 10 MHz, 15 kV; 20 MHz, 7 kV. Usable for dielectric heating, power and ultrasonic voltages. Price: HP 11039A, \$150. (Accessory HP 11018A should be used to connect the 410 series voltmeters.)

### 11040A capacitive voltage divider

For 410 series voltmeters. Increases range so transmitter voltages can be measured quickly, easily; accuracy,  $\pm 1\%$ . Division ratio, 100:1. Input capacity, approximately 2 pF. Maximum voltage, 2000 V at 50 MHz, decreasing to 100 V at 400 MHz. Frequency range 10 kHz to 400 MHz. Price: HP 11040A, \$35.

### 11044A dc voltage divider

For 410B Voltmeter. Gives maximum safety and convenience for measuring high voltages as in television receivers, etc. Accuracy,  $\pm 5\%$ ; division ratio, 100:1. Input impedance, 12 k megohms. Maximum voltage, 30 kV. Maximum current drain, 2.5  $\mu$ A. Price: HP 11044A, \$50.

### 11045A dc voltage divider

For 410C Voltmeter. Same as 11044A except input impedance, 10 k megohms. Price: HP 11045A, \$50.

## VOLTAGE, CURRENT, RESISTANCE



## VOLTMETER ACCESSORIES

Extend usefulness, versatility of HP voltmeters  
11018A Adapter

### 11018A Adapter

Connects 410 Series ac probe to dual banana plugs. Price: HP 11018A, \$35.

### 11033A Shunt Resistor

For 400 Series voltmeters to measure current to 40 mA full scale; accuracy  $\pm 1\%$  to 100 kHz,  $\pm 5\%$  to 4 MHz; maximum power dissipation, 1 watt; maximum voltage 24 V. Price: HP 11033A, \$20.

### 11036A Probe

AC probe for the 410C. Price: HP 11036A, \$60.

### 11042A Probe Coaxial "T" Connector

For 410 Series voltmeters. Measures voltages between center conductor and sheath of 50-ohm transmission line. Maximum SWR, 1.1 at 500 MHz, 1.2 at 1 GHz. Male and female Type N fittings. Price: HP 11042A, \$50.

### 11043A Probe Coaxial "N" Connector

For 410 Series voltmeters. Measures at open end of 50-ohm transmission line (no terminating resistor). Has male Type N fittings. Price: HP 11043A, \$37.50.

### 11066A Current Shunt

This current shunt can be used with any ac or dc voltmeter to make current measurements up to 10 amperes at dc or line frequencies up to 1 kHz. Designed for use with the HP Models 3440A/3443A or 3444A and 3460A Digital Voltmeters and the Model 740B and 741B Differential Voltmeters. Resistance; 0.01 ohm; accuracy;  $\pm 0.5\%$ ; temperature coefficient;  $\pm 100$  ppm/ $^{\circ}\text{C}$ ; power rating; 1.0 watt; maximum ambient temperature;  $65^{\circ}\text{C}$ ; maximum current; 10 amps. Price: HP 11066A, \$30.

### 11074A Voltage Divider Probe

For 400 Series voltmeters. Provides low-input capacitance and high-input resistance at the point of measurement. Division ratio 10:1  $\pm 2\%$  (400 Hz reference), 10:1  $\pm 2\%$  (100 kHz reference depends on adjustment of compensating capacitor). Bandwidth, dc to 10 MHz. Maximum input voltage 1 kV rms.

Input impedance: 10 megohms shunted by 10 pF (when connected to an input impedance of 10 megohms shunted by not more than 25 pF). Price: HP 11074A, \$45.

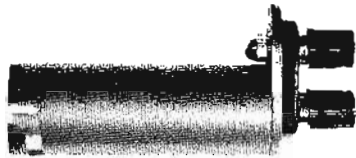

11018A

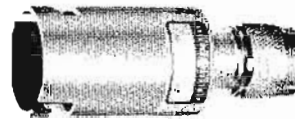

11043A



11033A



11036A

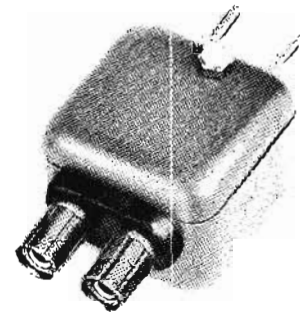

11066A



11042A



11074A

## CABLE ACCESSORIES

Cable assemblies



**VOLTAGE, CURRENT,  
RESISTANCE**

### 10501A Cable Assembly

44" of 50-ohm coaxial cable terminated on one end only with UG-88C/U BNC male connector; HP 10501A, \$3.50 each.

### 10502A Cable Assembly

9" of 50-ohm coaxial cable terminated on both ends with UG-88C/U BNC male connectors; HP 10502A, \$5.50 each.

### 10503A Cable Assembly

4' of 50-ohm coaxial cable terminated on both ends with UG-88C/U BNC male connectors; HP 10503A, \$6.50 each.

### 11000A Cable Assembly

Dual banana plugs terminate a section of 50-ohm cable, 44" over-all; plugs for binding posts spaced  $\frac{3}{4}$ "; HP 11000A, \$4.50 each.

### 11001A Cable Assembly

Identical with 11000A except dual banana plug on one end and UG-88C/U BNC male on the other; HP 11001A, \$5.50 each.

### 11002A Test Leads

Dual banana plug to alligator clips, 5'; HP 11002A, \$7.50 each.

### 11003A Test Leads

Dual banana plug to probe and alligator clip, 5'; HP 11003A, \$10 each.

### 11035A Cable Assembly

12" 50-ohm coaxial cable terminated on one end with a dual banana plug and on the other end with a UG-88C/U BNC male connector; HP 11035A, \$5.50 each.

### 11500A Cable Assembly

6' of specially treated 50-ohm coaxial cable terminated on both ends with UG-21D/U Type N male connectors; HP 11500A, \$15 each.

### 11501A Cable Assembly

6' of 50-ohm coaxial cable terminated with UG-21D/U Type N male and UG-23D/U Type N female; HP 11501A, \$15 each.

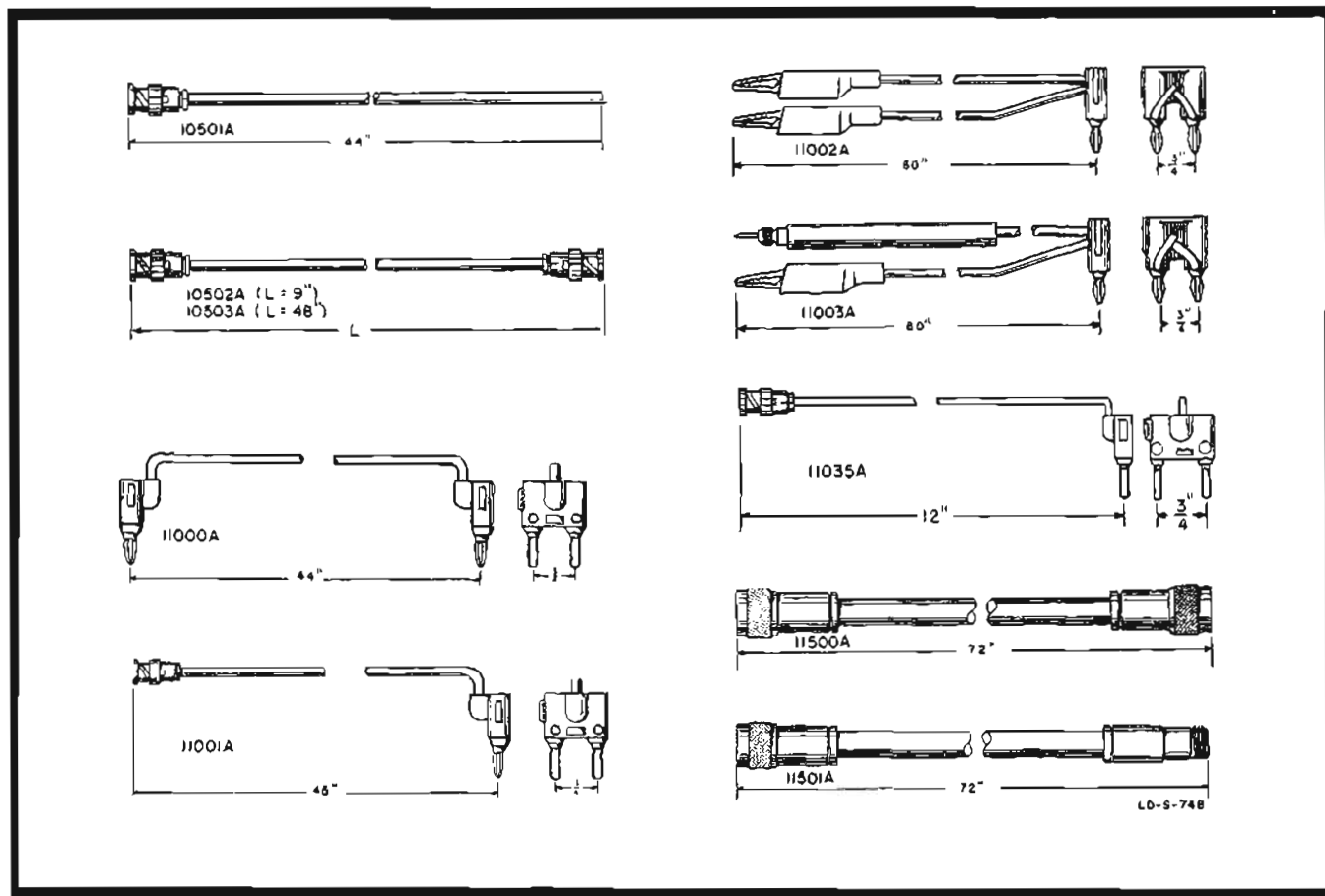

## VOLTAGE, CURRENT, RESISTANCE



## DIFFERENTIAL VOLTMETERS

Measurements made by the differential voltmeter technique (sometimes called a potentiometric or manual voltmeter) are recognized as one of the most accurate means of relating an unknown voltage to a known reference. These measurements are made by adjusting a precision resistive divider to divide down an accurately known reference voltage. The divider is adjusted to the point where the divider output equals the unknown voltage, as shown by the null voltmeter (Figure 1).

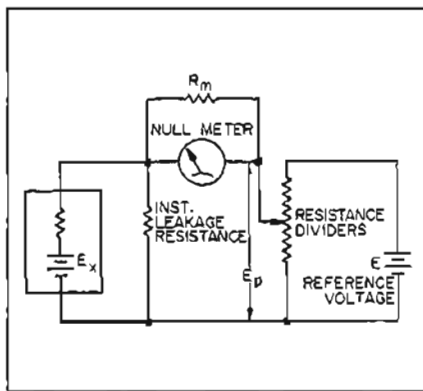

Figure 1. Classic differential voltage measurement.

The unknown voltage is determined to an accuracy limited only by the accuracies of the reference voltage and the resistive divider; the meter serves only to indicate any residual differential between the known and unknown voltage.

The differential method is highly accurate (Hewlett-Packard currently offers  $\pm 0.002\%$  accuracy).

A high-voltage standard is required to measure high voltage. This need may be overcome by inserting a voltage divider between the source and the null meter (Figure 2). This, however, results in relatively low-input resistance for voltages higher than the reference standard. This low-input resistance is undesirable because accurate measurements may not be obtained if substantial current is drawn from the source being measured. Most differential voltmeters used today offer input resistance approaching infinity only at a null condition, and then only if an input voltage divider is not used.

To overcome these limitations, Hewlett-Packard has developed an input isolation stage which develops an input resistance exceeding  $10^{10}$  ohms and measures voltages up to 1000 Vdc. This high resistance is maintained independent of null condition.

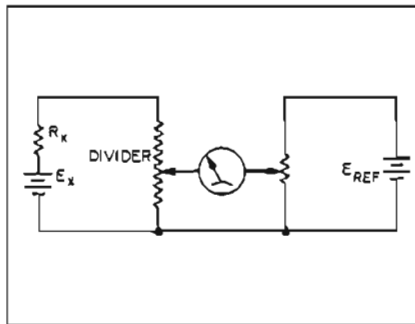

Figure 2. Potentiometric method of measuring unknown voltages.

As shown in the block diagram of Figure 3, the HP 740B DC Standard/Differential Voltmeter has the principal parts of the conventional differential voltmeter.

In a marked departure from conventional differential voltmeter design, the circuitry also includes a high-gain feedback amplifier as an impedance converter between the measured voltage source and the measurement circuits. The amplifier insures that the high-input impedance is maintained regardless of whether the instrument is adjusted for a null reading.

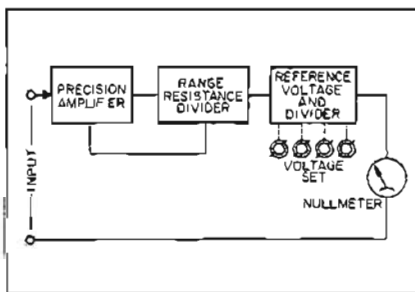

Figure 3. Simplified diagram of dc standard/differential voltmeter in differential voltmeter mode.

A further advantage provided by the amplifier is that the resistive voltage divider or RANGE "stick," which enables voltages as high as 1000 V to be compared to a precision 1 V reference, may be placed at the output of the amplifier rather than being in series with the measured voltage source. The isolation provided by the amplifier between the input and the RANGE "stick" thus enables the instrument to have high-input impedance on all ranges.

The range resistance divider and amplifier also permit the precision 1-V source to serve as the reference for standard output voltages up to 1000 V. Refer to page 174.

The voltage reference supply in the

740B is a Zener diode encased in an oven, resulting in stabilities better than 0.001%/month.

### Precision ac/dc differential voltmeter

The accuracy of ac voltage measurements has always been tempered by the lack of a primary standard of ac voltage. It is therefore necessary to measure ac voltages in terms of related dc voltages that, in turn, can be referenced to a dc standard. Highest accuracy in ac voltage measurements is acquired by a substitution technique that uses vacuum thermocouples to relate the ac to an accurate dc. Highly refined versions of this technique realize accuracies of 0.01%; but painstaking, time-consuming laboratory procedures are required for this level of accuracy.

The HP 741B now makes it possible to make ac and dc differential voltage measurements to better than  $\pm 0.03\%$  accuracy in fewer steps and without the environmental restrictions or precautionary measures required of thermocouple measurements. The HP 741B uses a precision rectifying circuit to convert the unknown ac directly to dc (equivalent to the average value of the ac), and the resulting dc is read to 5-place resolution by a potentiometric voltmeter technique. The measurement is straightforward in that the ac remains connected to the converter at all times and can be monitored continuously. Besides being a precision ac/dc differential voltmeter, the instrument is also an ultra-stable, high-resolution dc standard source. Refer to page 176 for additional information.

The accuracy of ac measurements is enhanced by the high-impedance probe attached to the instrument. The input impedance is 1 M $\Omega$  shunted by  $<5$  pF. The low-input capacitance is important in measurements where capacitance loading is critical. Using the 741B, it is possible to measure high ac voltages without drawing large reactive currents. Typical accuracy of the HP 741B AC Differential Voltmeter is shown in Figure 4.

A block diagram of the HP 741B in the ac differential voltmeter mode of operation is shown in Figure 5.

With compensation for both the frequency and the amplitude of the input signal, it has been possible to accomplish accurate ac-to-dc conversion that is linear over an amplitude range from 1/10 full scale to full scale throughout a broad frequency range. With proper calibration procedures, it is possible to reduce errors

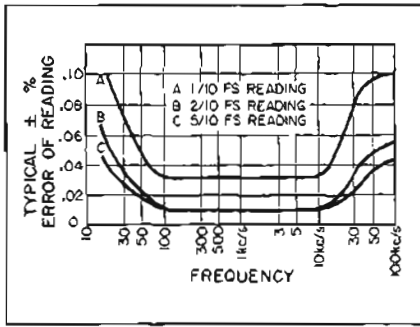

Figure 4. Typical accuracy of HP 741B AC Differential Voltmeter.

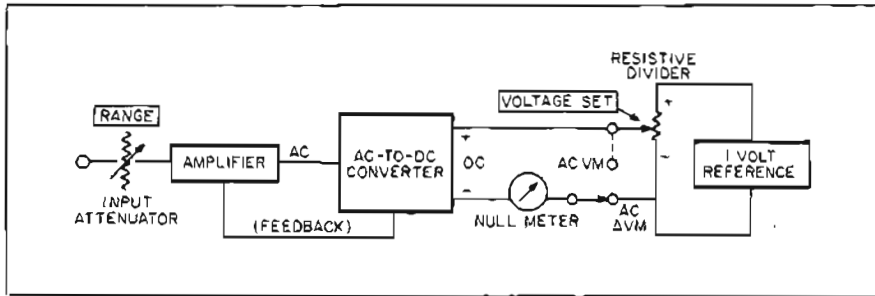

Figure 5. Simplified block diagram of an ac differential voltmeter.

to less than  $\pm 0.02\%$  of reading,  $\pm 0.002\%$  end scale between 100 Hz and 100 kHz under normal laboratory conditions.

**Differential voltmeter/ratiometer**

Recently introduced, the HP 3420A/B carries a 0.002% accuracy specification with stability of 1 ppm per hour (of range) and 5 ppm per day. Null meter resolution is 0.2 ppm of range on all ranges. These specifications set new standards in the state of the art for differential voltmeters.

To make 0.002% accuracy meaningful, the HP Models 3420A/B have six-digit decade dividers, plus the usual last-digit meter, and  $\pm 10 \mu\text{V}$  full-scale sensitivity. A further exclusive feature is battery operation, available in the 3420B version. A self-contained power source is important when it is necessary to measure dc voltages with common-mode noise. Because the instrument can be completely isolated from the power line, these common-mode voltages do not influence the reading.

A block diagram of the HP 3420A/B is shown in Figure 6. DC voltage measurements on the 1 and 10 V ranges are performed by the differential voltmeter technique, comparing the input voltage to a known internal voltage. This comparison is performed by a null meter. On the 100 V and 1000 V ranges, the input voltage is scaled to the 1 V level by a precision 10 M $\Omega$  resistance divider.

The outstanding accuracy of the instrument is controlled by the internal voltage reference supply and the precision resistor networks. To enable the instrument to operate on battery power, an oven was not used. A technique was developed to

adjust the dc temperature coefficient of the 11 V reference to  $< 1 \text{ ppm}/^\circ\text{C}$  over the range  $20^\circ\text{C}$  to  $30^\circ\text{C}$ . ( $< 2 \text{ ppm}/^\circ\text{C}$  from  $+10^\circ\text{C}$  to  $+40^\circ\text{C}$ ).

All six decades are binary-coded dividers. The first decade has a 10% over-range capability to aid in measuring standard cells and other voltages that occur slightly above full scale. This feature enables the user to determine measurements to  $< 1 \text{ ppm}$ .

The combination of high stability in the voltage reference supply, high resolution and zero stability in the null detector,

and six-decade divider gives a useful sensitivity of 0.2 ppm of range on all ranges.

Besides being a precision differential voltmeter, the 3420A/B is also a precision ratiometer.

When making dc voltage measurements, there are cases where the absolute value of the voltage is of little interest. Instead, the point of interest is its value in relationship to some other voltage level or the ratio of it to some other level, i.e.,

$$N = \frac{V_1}{V_2} = \frac{V_b}{V_a} = \text{Ratio}$$

This ratio appears often in engineering work. Examples are resistor dividers, potentiometer linearity, power at various voltage levels.

The basic specifications for Hewlett-Packard differential voltmeters are summarized in Table 1. In selecting a differential voltmeter, the user will be most interested in its accuracy and stability. Hewlett-Packard has the answer to the question, "Will the instrument offer both the voltage range and stability in anticipated tests?"

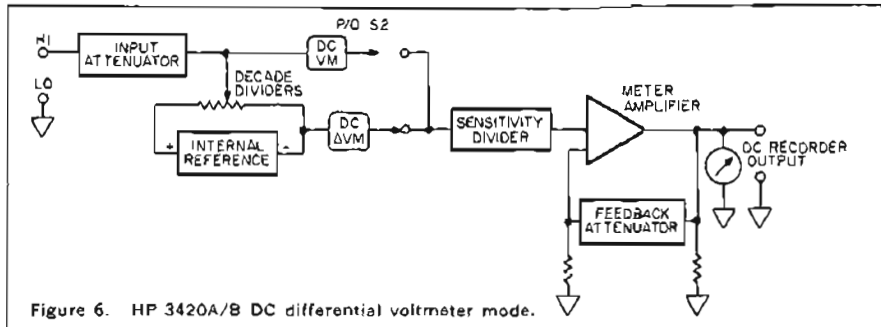

Figure 6. HP 3420A/B DC differential voltmeter mode.

**HEWLETT-PACKARD DIFFERENTIAL VOLTMETERS**

DIFFERENTIAL VM	740B (Refer to pg 212)	741B (Refer to pg 213)	3420A/B (Refer to pg 214)
Accuracy	AC	$\pm (0.02\% \text{ of rdg} + 0.01\% \text{ end scale})$	
	DC	$\pm (0.005\% \text{ of rdg} + 0.0004\% \text{ (rdg} + 1 \mu\text{V)})$	$\pm (0.002\% \text{ of rdg} + 0.0002\% \text{ of rge})$
Range	AC	1, 10, 100 and 1000 V end scale	
	DC	1, 10, 100 mV, 1 V, 10 V, 100 V & 1 kV	1, 10, 100 and 1000 V end scale with 10% overrange
Stability	Rated accuracy is met for 30 days	Rated accuracy is met for 90 days	Rated accuracy is met for 30 days
Input Resistance	$> 10^{10}$ ohms independent of null, 100 mV to 1kV range; $> 10^9$ on 10 mV range and $> 10^8$ on 1 mV range.	DC: $10^9$ ohms independent of null (all ranges). AC: 1 megohm shunted by $< 5 \text{ pF}$	1 & 10 V ranges: infinite at null, 100 & 1000 V ranges: 10 megohm $\pm 0.05\%$
Resolution	Meter	2 ppm	0.2 ppm
	Decades	10 ppm (5 digits)	100 ppm (4 digits)
Null Meter Sensitivity	$\pm 1 \mu\text{V}$ full scale	$\pm 1 \text{ mV}$ full scale	$\pm 10 \mu\text{V}$ full scale
DC Standard	Bonus (Refer to pg 174)	Bonus (Refer to pg 176)	
High Z Voltmeter	AC	No	No
	DC	Yes	Yes
Amplifier	Voltage	120 dB	100 dB
Voltage & Resistance Divider Ratio	No	No	Bonus (Refer to pg 214)
DC Recorder Output	Yes	Yes	Yes
Guarded Input	Yes	No (floating)	No (floating)
Battery Operation	No	No	Yes 3420B

**VOLTAGE, CURRENT,  
RESISTANCE**



**DIFFERENTIAL VOLTMETER**  
So much instrument at so great a value  
Model 740B

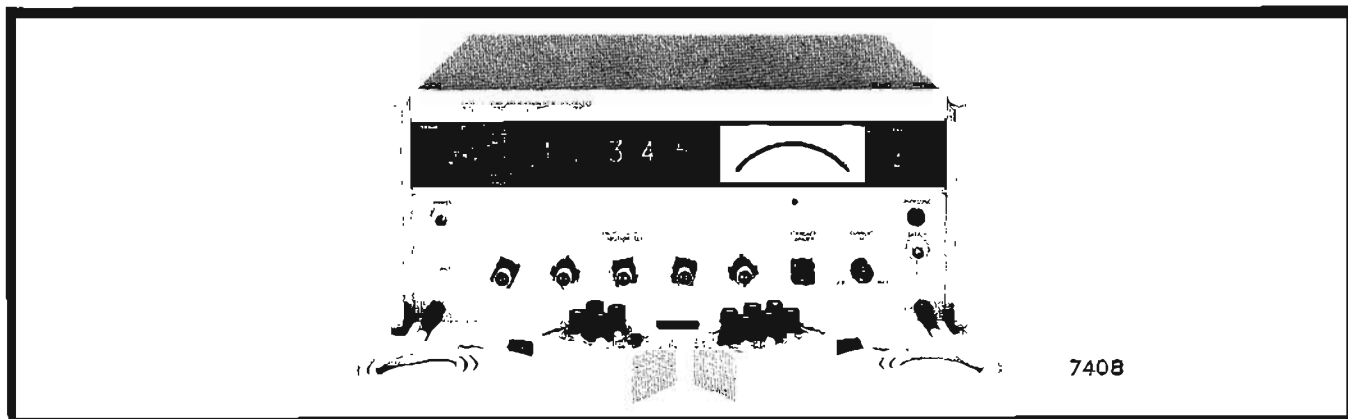

### Differential voltmeter

As a differential voltmeter, the 740B is unique in maintaining an input impedance of greater than  $10^{10}$  ohms (on all ranges above 10 mV) regardless of whether or not the voltage dials are nulled. This feature simplifies operation by eliminating any calculations of loading error by the voltmeter. In addition, the high-input impedance simplifies the measurement or comparison of standard cells or other devices sensitive to small current drains.

Voltage setting is indicated by five digital display tubes plus an individually calibrated taut-band meter.

### High-impedance voltmeter

The HP 740B is also a  $\pm 2\%$  floating and guarded voltmeter with ranges from 1  $\mu\text{V}$  to 1 kV. Input impedance is  $>10^{10}$  ohms on most ranges.

### Recorder output

Terminals provide an adjustable output voltage from 0 to 1 volt for end-scale meter deflection.

### DC standard

The 740B may also be used as a 0 to 1 kV  $\pm 0.002\%$  dc standard and a precision dc amplifier. For additional information refer to the Standards section of this catalog, pages 174-175.

### Specifications

#### DC differential voltmeter

**Voltage range:** 1 mV to 1000 V\* in 7 decade ranges.

**Resolution:** null ranges give full-scale indication of  $\pm 0.01\%$  of range. Max. resolution 1 ppm at full scale. Max. usable null sensitivity; 1  $\mu\text{V}$  full scale.

#### Performance rating

**Accuracy:**  $\pm (0.005\%$  of reading  $+ 0.0004\%$  of range  $+ 1 \mu\text{V})$  at  $+23^\circ\text{C} \pm 1^\circ\text{C}$ , less than 70% relative humidity.

**Stability:** rated accuracy is met after 1-hour warmup period, with a 30-day calibration cycle.

**Short-term:** 1 ppm/hr, 5 ppm/day, exclusive of zero drift ( $<100 \text{ V}$  input).

**Zero stability:** (1 ppm of range  $+ 2 \mu\text{V})$ /day.

**Temperature coefficient:**  $< \pm (2 \text{ ppm} + 1 \mu\text{V})/^\circ\text{C}$ ,  $+10^\circ\text{C}$  to  $+40^\circ\text{C}$ .

**Line regulation:**  $< \pm (0.001\% + 2 \mu\text{V})$  change for 10% line voltage change.

#### Input characteristics

**Input resistance:**  $>10^{10}$  ohms, 100 mV to 1000 V ranges;  $>10^9$  ohms on 10 mV range;  $>10^8$  ohms on 1mV range, independent of null condition.

**Superimposed ac noise rejection:**  $< 0.001\%$  error for ac voltages above 60 Hz equal to dc signal (25 V rms max.).

**Effective ac common-mode rejection:**  $>120 \text{ dB}$  at 60 Hz with 1 k $\Omega$  unbalance.

**Input terminals:** plus, minus, guard, and chassis ground. 500 V dc maximum may be connected between chassis ground and guard or circuit ground.

#### High-impedance voltmeter

**Voltage ranges:** 1  $\mu\text{V}$  to 1000 V\* end scale in 10 zero-centered ranges (1  $\mu\text{V}$  to 1 mV ranges obtained by using null sensitivity pushbuttons).

#### Performance rating

**Accuracy:**  $\pm 2\%$  of end scale  $\pm 0.1 \mu\text{V}$ .

#### Input characteristics

**Input resistance:**  $>10^{10}$  ohms, 100 mV to 1000 V ranges;  $>10^9$  ohms, 10 mV range;  $>10^8$  ohms, 1  $\mu\text{V}$  to 1 mV ranges.

**Zero control limits:**  $\pm 10 \mu\text{V}$  nominal.

**Zero drift:**  $< 2 \mu\text{V}$  per day after 30-minute warmup.

**Superimposed ac rejection:** ac voltages above 60 Hz; 60 dB greater than end scale affects reading less than 2% (25 V rms max.).

**Recorder Output:** adjustable 0 to  $\pm 1 \text{ V}$  dc at 1 mA for end scale meter indication. Recorder negative terminal common with input negative terminal.

#### General

**Operating temperature:**  $+10^\circ\text{C}$  to  $+40^\circ\text{C}$ .

**Storage temperature:**  $-40^\circ\text{C}$  to  $+65^\circ\text{C}$ .

**Power supply:** 115/230 V ac  $\pm 10\%$ , 50 to 1000 Hz, 125 watts max.

**Dimensions:** 16 $\frac{3}{4}$ " wide, 7" high, 18 $\frac{3}{4}$ " deep (425 x 117,8 x 476 mm). Rack mount kit (5060-0776) furnished with instrument.

**Weight:** net 47 lbs (21 kg); shipping 65 lbs (29,5 kg).

**Accessories furnished:** 11054A input cable for 740B; 11055B output cable for 740B.

**Price:** HP 740B, \$2350.

\*A maximum of  $-500 \text{ V}$  dc with respect to line ground can be applied to or obtained from the HP 740B.

# AC/DC $\Delta$ VM/DC STANDARD

Rugged instrument has standards lab accuracy  
Model 741B



**VOLTAGE, CURRENT,  
RESISTANCE**

## AC differential voltmeter

As an ac differential voltmeter, the 741B is unique in maintaining a low input capacitance of  $<5$  pF. The low input capacitance is important in measurements where capacitance loading is critical. Using the 741B, it is possible to measure high ac voltages without drawing large reactive currents. The 741B measures ac voltage from 1 mV to 1000 V from 20 Hz to 100 kHz. This new instrument makes it possible to make ac and dc differential voltage measurements in fewer steps and without the environmental restrictions or precautionary measures required of thermocouple measurements.

## DC differential voltmeter

As a dc differential voltmeter, the HP 741B measures dc voltages from 0 to 1000 V in 4 ranges with an accuracy of  $\pm 0.02\%$  of reading\*\* or  $\pm 0.002\%$  of range. The input impedance is  $>10^9$  ohms on all ranges independent of null. The 741B Option 01 offers  $\pm 0.01\%$  accuracy in dc differential voltmeter mode of operation and  $\pm 0.02\%$  accuracy in dc standard operation. All other specifications in the 741B Option 01 are identical to the standard 741B. The standard 741B or 741B Option 01 can be calibrated by the user to operate as a  $\pm 0.01\%$  dc standard or dc differential voltmeter with only one adjustment.

## DC standard source

The 741B is an ultra-stable, high-resolution dc standard source which delivers output voltage from 0 to 1000 V with standards lab accuracy. Refer to page 176 for additional information.

## Specifications

### AC differential voltmeter

**Input voltage ranges:** 1, 10, 100, 1000 V end scale; with null ranges end scale, 1 mV to 1000 V.

**Voltage resolution:** 0.004% end scale.

### Performance rating

**Accuracy:**

Accuracy (% of reading)	50 mV-1 kV	1 mV-50 mV	50 mV-100 V
0.02% + 0.01% of range			400 Hz-5 kHz
0.04% + 0.01% of range	100 Hz-10 kHz		
0.1% + 0.01% of range	50 Hz-50 kHz		
0.15% + 0.01% of range	30 Hz-50 Hz		
0.2% + 0.01% of range	20 Hz-30 Hz 50 kHz-100 kHz		
0.2% + 0.02% of range		20 Hz-50 kHz	
<80% relative humidity			

**Stability:** rated accuracy is met after 1-hour warmup period, with a 90-day calibration cycle from 20 Hz to 20 kHz and a 30-day calibration cycle from 20 kHz to 100 kHz.

**Short-term stability:** better than 50 ppm/day 20 Hz to 20 kHz.

**Line regulation:**  $\pm 0.01\%$  change for  $\pm 10\%$  line-voltage change.

### Temperature coefficient

$<20$ ppm/ $^{\circ}$ C, 20 Hz - 10 kHz;	5-40 $^{\circ}$ C.
$<60$ ppm/ $^{\circ}$ C, 20 - 100 Hz, 10 kHz - 100 kHz;	5-40 $^{\circ}$ C.
$<40$ ppm/ $^{\circ}$ C, 20 Hz - 10 kHz;	0-50 $^{\circ}$ C.
$<80$ ppm/ $^{\circ}$ C, above 10 kHz;	0-50 $^{\circ}$ C.

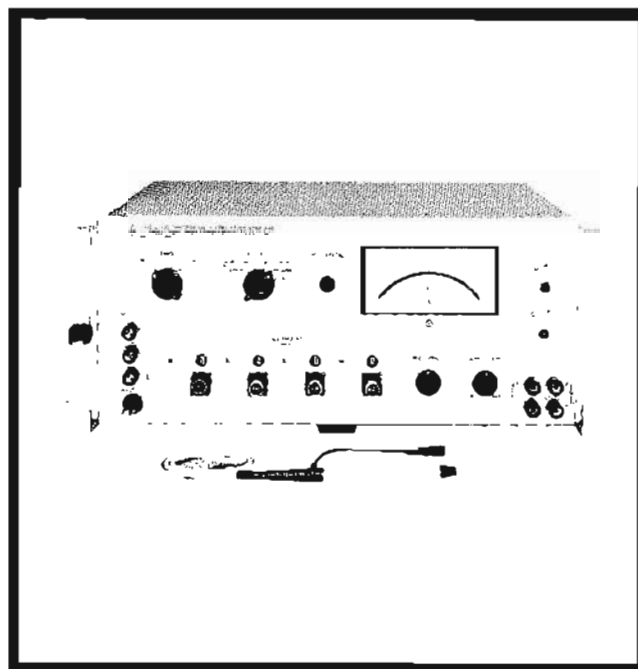

### Input characteristics

**Input impedance:** 1 megohm shunted by less than 5 pF.

**Input:** probe with 3-ft. cable. Can be floated to 500 V dc max.

### DC differential voltmeter

**Voltage ranges\*:** 1 V to 1000 V end scale, with null ranges end scale, 1 mV to 1000 V.

**Voltage resolution:** 0.002% end scale.

### Performance rating

**Accuracy\*\*:**  $\pm 0.02\%$  of reading or  $\pm 0.002\%$  of range, whichever is greater. Relative humidity  $<80\%$ .

**Stability:** rated accuracy is met after 1-hour warmup period, with a 90-day calibration cycle.

**Short-term stability:** 10 ppm for a 24-hour period.

**Line regulation:**  $\pm 0.002\%$  change for  $\pm 10\%$  line voltage change.

**Temperature coefficient:**  $<3$  ppm/ $^{\circ}$ C from 0 $^{\circ}$ C to +50 $^{\circ}$ C. **Input impedance:**  $>10^9$  ohms on all ranges (independent of null).

**Input:** floating (up to 500 V dc max.).

**Superimposed ac noise rejection:**  $<0.01\%$  error (above 50 Hz) for ac rms voltage equal to 50% of input dc or 25 V rms, whichever is less.

### General

**Recorder output:** available for all modes of operation.

**Recorder amplifier:** recorder voltage output directly proportional to meter deflection, 60 dB gain (max.), 1 mA into 1 k $\Omega$  d.

**Power supply:** 115 or 230 V  $\pm 10\%$ , 50 Hz to 1000 Hz, 125 W max.

**Weight:** net 47 lbs (21 kg); shipping 65 lbs (29.5 kg).

**Dimensions:** 7" high, 16 $\frac{3}{4}$ " wide, 18 $\frac{1}{4}$ " deep (178 x 425 x 464 mm).

**Price:** HP 741B, \$1675; HP 741B Option 01, on request.

\*A maximum of -500 V dc with respect to line ground can be applied to or obtained from the HP 741B.

\*\*741B Option 01 provides  $\pm 0.02\%$  dc standard accuracy and  $\pm 0.01\%$  dc differential voltmeter accuracy.



**VOLTAGE, CURRENT,  
RESISTANCE**



**VOLTMETER/RATIOMETER**  
1 ppm stability with  $\pm 0.002\%$  accuracy  
Models 3420A/B

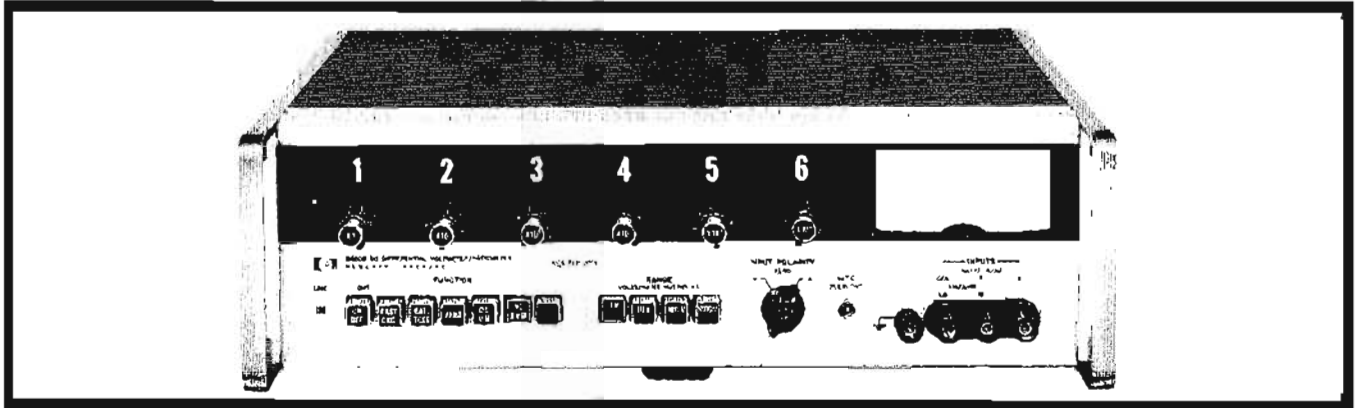

**Rapid Null Meter Zero Adjustment**

The decade dividers need not be adjusted to zero when zero-setting the null-meter. When ZERO pushbutton is depressed, it automatically disconnects the input signal and shorts the input of the 3420A/B for precise null-meter zero adjustment.

**Ratiometer**

The HP 3420A/B may be used to measure resistance divider and voltage ratios rapidly without using the conventional method of tedious mathematical computations when ratios are required instead of absolute values. Voltage and resistance ratios from 0.00000001:1 to 0.999999:1 in four ranges X1, X0.1, X0.01, and X0.001 can be measured. The dial resolution on all ranges is 1 ppm of range with null sensitivity at the calibrate voltage (A to Common) at 0.2 ppm of range. Accuracy on all ranges is 20 ppm of reading  $\pm 4$  ppm of range.

**Line and/or Battery Operation (3420B only)**

The 3420B, identical to the 3420A except for battery operation, is powered from either line or battery power. When operated from line power, the nickel-cadmium batteries are trickle charged and may be charged indefinitely without damage. A fast-charge pushbutton can be depressed for rapid (15 hours) charging of the batteries. The 3420B will operate on batteries for 30 hours before recharging is necessary. A pushbutton is also provided to read the battery voltage on the null-meter to determine if battery charging is necessary. Besides true portability, battery power offers complete line isolation eliminating troublesome ground loops when making precision measurements.

**Immunity to Damage by Overloads**

The 3420A/B has very high immunity to damage by overloads. The instrument can accept without damage 1100 volts on any range or null sensitivity. The meter recovers from overloads as high as  $10^6$  in less than three seconds.

**DC Recorder Output**

An output signal proportional to the null-meter deflection is adjustable from 0 to 1 volt and can supply 1 milliamp to drive recorders. In the most sensitive position, this output provides  $\pm 10$  ppm of range full scale.

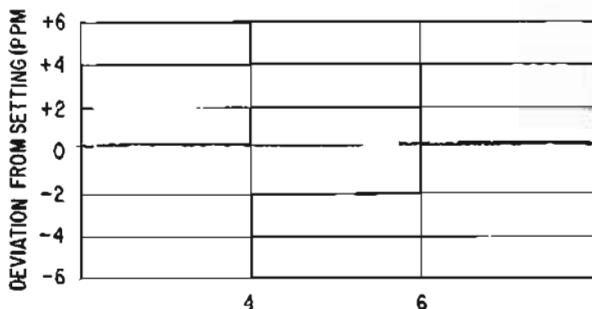

## Specifications

### DC differential voltmeter

**Ranges:**  $\pm 1$ ,  $\pm 10$ ,  $\pm 100$  and  $\pm 1000$  volts with up to 10% over-ranging available on all ranges.

**Resolution:** six dials provide 1 ppm (parts per million) of range. Null meter provides full scale indication of 10 ppm of range with maximum resolution of 0.2 ppm on all ranges.

#### Performance rating:

**Accuracy:**  $\pm (0.002\%$  of reading  $+0.0002\%$  of range) at  $23^\circ\text{C} \pm 1^\circ\text{C}$ , less than 70% R.H. (relative humidity).

**Stability:** rated accuracy is met after a 1-hour warmup period, with a 30 day calibration cycle.  $\pm 0.005\%$  accuracy within 30 seconds of turn on. Short Term: 1 ppm/hour, 5 ppm/day exclusive of zero drift.

Zero Stability: 0.5 ppm per day of range.

**Temperature coefficient:** Tref. =  $23^\circ\text{C}$ .

	$20^\circ\text{-}30^\circ\text{C}$	$10^\circ\text{-}20^\circ\text{C}$ and $30^\circ\text{-}40^\circ\text{C}$
11 volt reference	$\pm 1.0$ ppm/ $^\circ\text{C}$	$\pm 2.0$ ppm/ $^\circ\text{C}$
Total instrument exclusive of zero drift	$\pm 4$ ppm/ $^\circ\text{C}$ of reading	$\pm 5$ ppm/ $^\circ\text{C}$ of reading

Zero drift  $< 0.25$  ppm of range/ $^\circ\text{C}$ ,  $10^\circ$  to  $40^\circ\text{C}$ .

**Off null accuracy:**  $\pm 3\%$  of sensitivity setting.

**Line regulation:** 1 ppm for 10% line voltage change.

#### Input characteristics:

$\Delta$ VM range	Input resistance
1 V 100 V	Infinite ( $> 10^{11}\Omega$ @ $< 70\%$ R.H.) at null $10\text{ M}\Omega \pm 0.05\%$

Null Detector range	Input resistance
10 $\mu\text{V}$ -10 mV 100 mV-10 V	1 M $\Omega$ 10 M $\Omega$

Input is open circuit except when a VM,  $\Delta$ VM, or Ratio button is depressed.

#### Superimposed ac rejection:

AC voltages (60 Hz and above) with rms value equal to the dc input voltage causes  $< 0.0008\%$  error in the reading. Maximum ac input: 25 V rms on the 1 V range, and 200 V on all other ranges.

#### Isolation parameters:

**Input:** floating binding posts on the front panel may be operated up to  $\pm 1000$  V dc with respect to chassis ground (700 volts rms).

**Battery operation (3420B):** provides complete isolation from external circuits.

**Line operation (3420A/B):** common-mode rejection is the ratio of common-mode signal to resultant error in readout, with 1 K $\Omega$  unbalance.

At dc:  $> 140$  dB on all ranges at less than 70% R.H.

At 60 Hz and above:  $> 150$  dB on all ranges.

**Output signals:** recorder output adjustable from 0 to  $\pm 1$  V dc, 1 mA maximum current. Output is proportional to meter deflection. (Low side of recorder common to low side of input.)

#### Operation features:

##### DC voltmeter operation:

**Ranges:** 10  $\mu\text{V}$  to 1 kV in nine decade ranges.

**Accuracy:**  $\pm 3\%$  of end scale.

**Input resistance:** 10  $\mu\text{V}$  to 10 mV range: 1 M $\Omega$ ; 100 mV to 1000 V range: 10 M $\Omega$ .

**Input zero:** a pushbutton switch is provided to automatically disconnect the input terminal and short the amplifier. Nominal zero adjustment range:  $\pm 15$  ppm of range.

**Polarity selection:** switch is provided to allow measurement of positive or negative voltage with respect to circuit common.

#### Calibration resolution:

Voltage reference: 1.1 V and 11 V; 0.5 ppm of output.

1st and 2nd decades: 0.5 ppm of resistance ratio.

Input range attenuator: 1 ppm of resistance ratio.

**Meter:** individually calibrated taut-band suspension.

#### Extreme operation conditions:

**Overload protection:**  $\pm 1000$  V dc may be applied on any range or sensitivity for up to 1 minute without damaging the instrument.

**Overload recovery:** meter indicates within 3 sec. after removing  $10^4$  overload factor.

### DC ratiometer

**Ranges:** X1, X.1, X.01, and X.001 with six-digit in-line readout.

**Resolution:** same as  $\Delta$ VM.

#### Performance rating\*

**Accuracy:**  $\pm (0.002\%$  of reading  $+0.0004\%$  of highest decade setting) at  $23^\circ\text{C} \pm 1^\circ\text{C}$ , less than 70% relative humidity.

**Stability:** rated accuracy is met after a 30-second warmup period, with a 60-day calibration cycle.

**Short term:** 0.5 ppm/hour, exclusive of zero drift.

**Zero stability:** 0.5 ppm of range/day.

**Temperature coefficient:** X1 range: 1 ppm/ $^\circ\text{C}$ , X0.01 range and above: 5 ppm/ $^\circ\text{C}$ , to  $40^\circ\text{C}$ .

#### Input characteristics:

**Input 3 terminals:** A, B, Common

Ratio =  $\frac{B \text{ to Common}}{A \text{ to Common}}$

With A  $>$  B and same polarity

**Input voltage ratio:** null meter calibrated to read directly in ppm

of range for lowest A-to-Common calibration voltage indicated in table below.

Range	Calibrated A to Common	Maximum A to Common
X 1	1-10 V dc	50 V
X.1	10-70 V dc	90 V
X.01	100-500 V dc	500 V
X.001	1000 V dc	1200 V

\*For calibrated A to Common voltage shown in table.

#### Input resistance:

Terminal B to Common: Infinite at null ( $> 10^{10}\Omega$  @ 70% R.H.). Terminal A to Common: Range: x 1, 10 k $\Omega$ ; x.1, 100-k $\Omega$ ; x.01, 1 m $\Omega$ ; x.001, 10

**Superimposed ac rejection:** 60 Hz signals equal to 100% of A to Common dc affects reading less than 2 ppm of meter reading.

#### Isolation parameters:

Same performance as for  $\Delta$ VM.

#### Output signal:

Recorder output has the same capability as for the  $\Delta$ VM, except recorder must be isolated from ground by  $10^{10}\Omega$ .

### General

**Input power:** 3420A: 115 or 230 volts  $\pm 10\%$ , 50 to 1 kHz.

Approximately 2 watts.

3420B: Battery/Line Operation; Rechargeable batteries (8 furnished). 30 hours operation per recharge. Instrument may be operated during normal recharge from ac line. Provision is made for testing the battery condition and selecting a fast (15 hour) charging rate. Input for battery charging 115 or 250 volts,  $\pm 10\%$ , 50 to 1000 Hz, 3 watts.

**Dimensions:** 5" high, 16 $\frac{3}{4}$ " wide, 13 $\frac{3}{4}$ " long (127 x 425 x 324 mm).

**Weight:** net 21 lbs (9.45 kg), shipping 27 lbs (12.2 kg).

**Price:** HP 3420A, \$1175. HP 3420B, \$1300.

# VOLTAGE, CURRENT, RESISTANCE



## DIGITAL VOLTMETERS

Digital voltmeters (DVM's) display measurements as discrete numerals, rather than as a pointer deflection on a continuous scale commonly used in analog devices. Direct numerical readout in DVM's reduces human error and tedium, eliminates parallax error and increases reading speed. Automatic polarity and range-changing features reduce operator training, measurement error and possible instrument damage through overload.

Digital instruments are available to measure ac and dc voltages, dc currents and resistance. Other physical variables can also be measured by use of suitable transducers. Many have outputs to make permanent records of measurements with printers, card and tape punches, and magnetic tape equipment. With data in digital form, it may be processed with no loss of accuracy.

Most popular digital voltmeters on the market today fit into one of the following categories: (1) ramp, (2) staircase ramp, (3) integrating, (4) integrating and potentiometric, (5) successive approximation, and (6) continuous balance (potentiometric).

Types currently in use by HP are described below.

**Ramp Types:** the operating principle of the ramp digital voltmeter is to measure the time a linear ramp takes to change from the input level to ground (or vice versa). This time period is measured with an electronic time-interval counter and displayed on in-line indicating tubes. The advantages of this type of instrument are low price and simplicity. Conversion of a voltage to a time interval is illustrated by the timing diagram in Figure 1. At the start of a measurement cycle, a ramp voltage is initiated. The ramp is compared continuously with the voltage being measured; at the instant they become equal, a coincidence circuit generates a pulse which

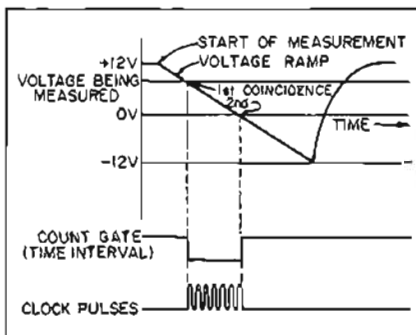

Figure 1. Voltage-to-time conversion.

opens a gate. The ramp continues until a second comparator circuit senses that the ramp has reached zero volts. The output pulse of this comparator closes the gate.

The time duration of the gate opening is proportional to the input voltage. The gate allows pulses to pass to totalizing circuits, and the number of pulses counted during the gating interval is a measure of the voltage.

A block diagram of the HP3440A Digital Voltmeter illustrates this technique in Figure 2.

It has an accuracy of  $\pm 0.05\%$  of reading with reading rates up to 5 per second. These features, coupled with its

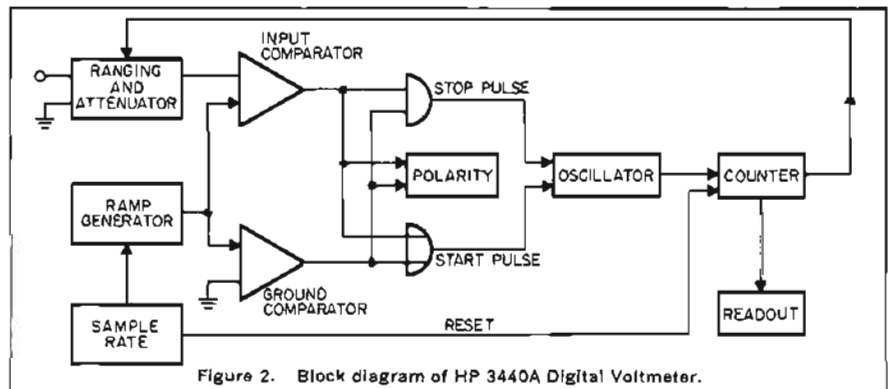

Figure 2. Block diagram of HP 3440A Digital Voltmeter.

capability of 10  $\mu\text{V}$  resolution, 4-digit readout, and plug-in versatility, make it a popular and economical choice.

Recently introduced, the HP 3430A is

reached, the number of accumulated counts (representing the input voltage) is displayed on the front-panel display. The instrument retains the displayed

QA inspection stations. The new DVM has a floating input, a feature not commonly found in digital voltmeters of this price. An optional version of the instrument permits ratio measurements, a useful feature for normalizing the readings of dc transducer outputs and taking readings using an external reference.

Referring to Figure 3, the 3430A is the staircase ramp-type which compares the input voltage to an internally-generated voltage derived from a Zener reference diode and precision resistors. The internally-generated voltage starts from zero and is stepped automatically to successively higher values until it matches the input voltage. Each step advances a counter one digit; when coincidence is

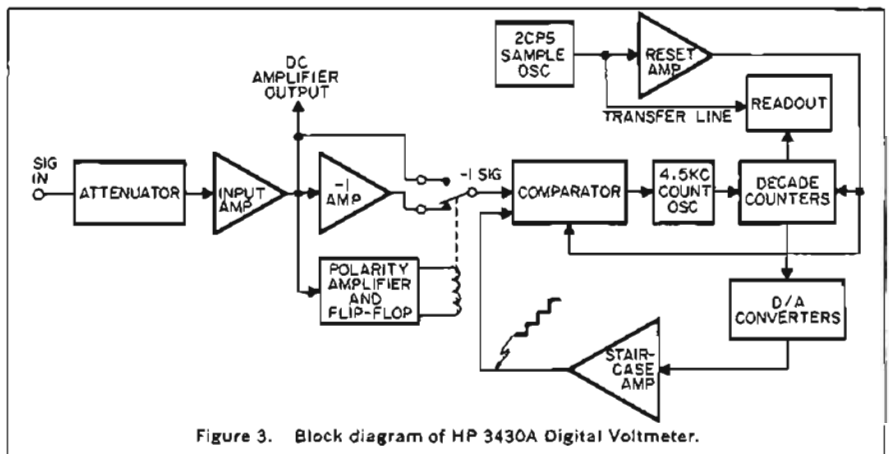

Figure 3. Block diagram of HP 3430A Digital Voltmeter.

a 3-digit digital voltmeter not much more costly than an analog voltmeter. The speed, convenience, and accuracy of digital readout now becomes available at a moderate price for general-purpose applications in the laboratory, on production test stands, in repair shops, and at

number until the next measurement cycle is completed. The display is continuous. There is no blinking.

**Integrating Types:** an integrating digital voltmeter measures the true average of the input voltage over a fixed measuring period, in contrast to ramp-types

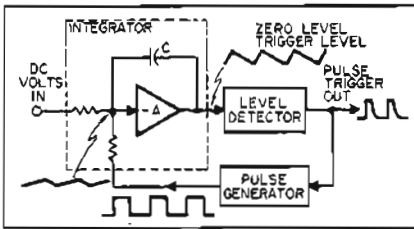

Figure 4. Voltage-to-frequency conversion.

which measure the voltage at the end of the measuring interval. A widely-used technique to accomplish integration is the use of a voltage-to-frequency converter, as indicated in Figure 4. The circuitry functions as a feedback control system which governs the rate of pulse generation, making the average voltage of the rectangular pulse train equal to the dc input voltage.

The major advantage of this type of analog-to-digital conversion is its ability to measure accurately in the presence of large values of superimposed noise, because the input is *integrated* over the sampling interval. The reading represents a true average of the input voltage. (Symmetrical ac interference waveforms average to zero.)

The HP 2401C Integrating Digital Voltmeter, in the 0.01% accuracy class, uses the voltage-to-frequency conversion technique, achieving outstanding ability to reject the effects of *superimposed* noise; it achieves *common-mode* noise rejection by guarding.

This model applies especially well to measurements of extremely noisy signals, even rejecting noise up to 100% of full-scale readings down to 99.999 mV without an accessory amplifier. Speed, and complete remote-control ability, make it ideal for system applications. It can also be used as an electronic counter to measure frequency or period.

**Integrating/Potentiometric Types:** by using techniques exploiting the best qualities of several systems, a totally new result is achieved in the HP 3460B. Besides being an integrating-type voltmeter which continually measures the true average of the input voltage, it is also a potentiometric type obtaining high accuracy from precision resistance ratios and a stable reference voltage. A block diagram of the Integrating/Potentiometric Digital Voltmeter is shown in Figure 6.

The HP 3460B is a good choice for applications requiring extremely high accuracy ( $\pm 0.004\%$ ) and high speed with high resolution. The 3460B takes up to 15 readings per second with more than 5-digit resolution (1.20000 full scale). Since the instrument is guarded, all readings can be made in the presence of large common-mode signals. The integration characteristic also allows a maximum reading rate, even with noise superimposed on the signal.

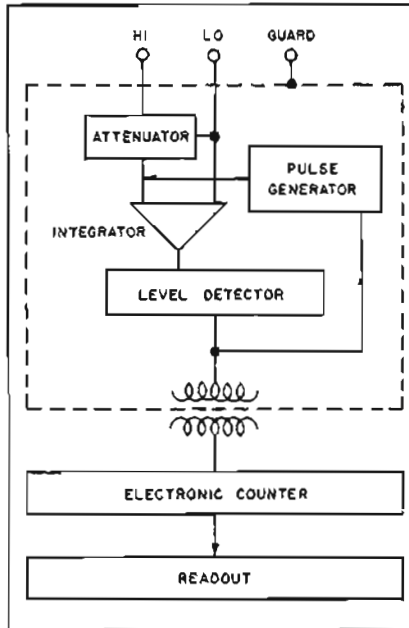

Figure 5. Block Diagram Model 2401C DVM.

To be useful as the central analog-to-digital converter in an automatic system, a DVM must have several features which are not needed in a bench meter. Among these are binary-coded decimal output, and remote controls. If system use is not intended, cost can be reduced by omitting these features.

The HP 3459A, stripped of system features, has accuracy to 0.008% over a wide range of environmental conditions. With maximum ability to reject the effects of both superimposed and common-mode noise, Model 3459A is also the least costly instrument in this accuracy class.

Similar to the 3460B, the HP H04-3460A has a resolution of 1 part in 1,200,000 and a sensitivity of 1  $\mu$ V on the 1 volt range. Its measurement and accuracy is 0.005% of reading.

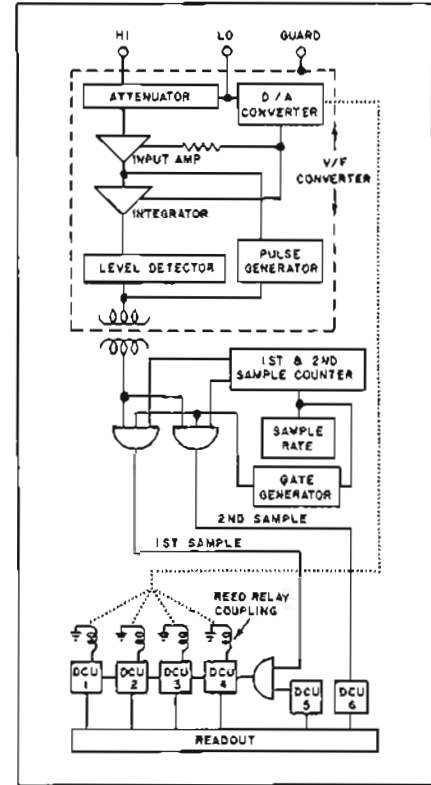

Figure 6. Block diagram of HP 3460B DVM.

### Selecting a Digital Voltmeter

If the DVM is to be used in a data acquisition system, binary-coded decimal (BCD) output and remote programming ability are necessities. Compatibility with related equipment (see page 78) should be determined.

When selecting a digital voltmeter to make accurate measurements in the presence of noise, the digital voltmeter must discriminate the real signal from the noise appearing at its input terminals. Noise rejection by integration permits high accuracy in the presence of severe noise

Table 1. Hewlett-Packard Digital Voltmeters.

Model (Type)	Accuracy (% of reading)	Nbr. Digits (Overrange %)	Speed (Max.) Readings/sec	AC Volts	DC Volts	DC Amps	Ohms	Ratio	Auto Ranging	Floating Input	Guarding (CMR)	Printer Output	Remote Ranging	Remote Triggering	Plug-Ins	Systems Application
Integrating/Potentiometric \$2850 to \$4250																
H04/3460A (pg 232)	0.005	6 (120)	1		X				X	X	X	X	X	X		X
3460B (pg 228)	0.004	5 (120)	15	+	X		+		X	X	X	X	X	X		X
3459A (pg 229)	0.008	5 (120)	1.7		X				X	X	X	*		X		
Integrating \$3950																
HP-2401C (pg 225)	0.01	5 (300)	1**	#	X		#		*	X	X	X	X	X		X
Ramp \$595 to \$1195																
3440A (pg 220)	0.05	4 (105)	5	X	X	X	X		X	X			X	X	X	X
3439A (pg 220)	0.05	4 (105)	5	X	X	X	X		X	X			X		X	
3430A (pg 219)	0.1	3 (160)	2		X			*		X						

\*Optional: -HP-2410B AC/Ohms Converter; -HP 3461A AC/Ohms Converter.  
 \*\*4 digits/9 readings per sec; 3 digits/50 readings per sec.

conditions. The integrating digital voltmeter reads the average value of the input signal and fits into an attractive price class.

Noise on the signal may be inexpensively reduced by equipping the digital voltmeter with a passive input filter. Filtering need not degrade voltmeter accuracy, but it reduces measurement speed. Consideration of speed must be made if the digital voltmeter is to be used in data acquisition systems.

Common-mode pickup, emf's common to both high and low-terminals, is frequently a severe measurement problem. Guarding, which virtually eliminates the effects of common-mode noise, could be highly important. The ability to track signals around zero may be needed, in which case inclusion of a bi-directional counter (HP 2401C and HP 3460B may be desirable. Refer to Table 1 — a Hewlett-Packard DVM is available to meet most application requirements.

AC/DC Converters: the ac-to-dc converter (Figure 7) typically produces a dc output voltage between 0 and 1 V dc proportional to the average value of the applied ac voltage calibrated in rms.

The frequency range for precision ac measurements (0.1% or better) has been restricted to the audio range but is continually being extended. Measurement speeds for ac voltage depend on the frequency of the voltage and the measurement accuracy desired.

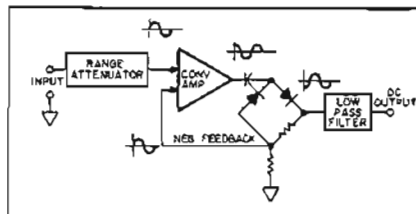

Figure 7. Typical ac/dc converter.

Ohms-to-Dc Converter: the ohms-to-dc converter, frequently an additional function of ac-to-dc converters, produces a dc output voltage between 0 and 1 V dc proportional to the value of the unknown resistance applied. Most ohms-to-dc converters require a high input impedance dc preamplifier.

The new HP 3461AC/Ohms Converter DC Preamplifier has maximum compatibility with the 3460B, with which it measures ac voltages up to 1200 V rms,

and resistances up to 12 megohms. It is fully guarded, automatic ranging on all functions, and is remotely programmable.

The compatible AC-ohms converter for the 2401C is the HP Model 2410A.

Plug-in AC/DC Converters: the HP 3445A and 3446A Plug-ins are companions to the HP 3439A and 3440A Digital Voltmeters.

Analog Voltmeters used as AC/DC Converters: connect any dc DVM with a 1 V dc range to the dc output of an analog voltmeter, such as the HP 400E/EL. The 400E/EL gives good accuracy as an ac-to-dc converter in its mid-frequency range from 50 Hz to 500 kHz. It has typically <0.4% of reading error, even at 1/10 full scale, 200 Hz to 400 kHz.

True rms measurements from 10 Hz to 10 MHz can similarly be made by combining any dc digital voltmeter having a 1-volt range with the HP 3400A RMS Voltmeter.

Typical specifications of Hewlett-Packard ac-to-dc and ohms-to-dc converters are listed in Table 2.

Table 2. Hewlett-Packard AC/Ohms Converters.

HP CONVERTER TYPE (REFER TO PAGE)	COMPANION HP DVM	RANGES	AUTO RANGING	FLOATING	GUARDED	PLUG-INS	REMOTE RANGING	REMOTE TRIGGERING	SYSTEMS APPLICATION	ACCURACY OF CONVERTER	Can be used with other 1 V range DVM's
<b>AC to DC</b>											
3461A (pg 230)	3460B	1 to 1000 V 4 ranges	X	X	X	*	X	X	X	(50 Hz - 100 kHz) ±0.1% to ±0.25%	Yes
2410B (pg 227)	2401C	0.1 to 1000 V 5 ranges	†	X	X		X	X	X	(20 Hz - 100 kHz) ±0.15 to 0.4%	Yes
3445A/3446A (pg 224)	3439A-3440A	10 to 1000 V 3 ranges	X	X		X	X	X	X	(50 Hz - 100 kHz) ±0.1% to ±0.3%	No
457A (pg 234)		1 mV - 1000 V 4 ranges		X						(50 Hz - 500 kHz) ±0.2%	Yes
3400A (True rms) (pg 196)	3439A-3440A	1 mV - 300 V 12 ranges								(10 Hz - 10 MHz) ±0.75% to ±3%	Yes
400E/EL (Avg) (pg 188)	3439A-3440A	1 mV - 300 V 12 ranges								(10 Hz - 10 MHz) ±0.5% to +4% / -10%	Yes
<b>OHMS to DC</b>											
3461A (pg 230)	3460B	1 kΩ to 10 MΩ 5 ranges	X	X	X	*	X	X	X	±0.008 to ±0.014%	Yes
2410B (pg 227)	2401C	100Ω to 10 MΩ 6 ranges	†	X	X		X	X	X	±.06%	Yes
3444A (pg 223)	3439A-3440A	1 kΩ to 10 MΩ 5 ranges		X		X			X	±0.3% to ±1%	No
<b>DC AMPLIFIERS</b>											
3461A (pg 230)	3460B	0.1 V dc to 10 V dc 5 ranges	X	X	X	*	X	X	X	±0.004% (to ±0.005% + 2μV)	Yes
2411A (pg 227)	2401C	+1, +10 gain		X	X		X	X	X	±.03%	No
3443A (pg 222)	3439A-3440A	100 mV to 1 kV 5 ranges	X	X		X	X	X	X	±0.05% to ±0.1%	No
3444A (pg 223)	3439A-3440A	100 mV to 1 kV 5 ranges		X		X		X	X	±0.05%	No

\*Optional plug-in circuit boards. †Standard 2410B autoranges with 2401C-M31.

# DIGITAL VOLTMETER

Precision at the price of analog voltmeters  
Model 3430A



**VOLTAGE, CURRENT,  
RESISTANCE**

## Description

The new Hewlett-Packard Digital Voltmeter offers accurate measurements at the price of analog voltmeters. The 3430A can be used on the bench, and with an adapter, can be rack mounted. The 3430's solid-state construction offers continuous service under rigorous operating conditions. This voltmeter is accurate and easy to read—easily operated by inexperienced personnel.

The Hewlett-Packard Model 3430A Digital Voltmeter is a precision instrument permitting dc voltage measurements from  $\pm 100.0$  mV full scale to  $\pm 1000$  V within  $\pm (0.1\% + 1 \text{ digit})$  within a 90-day calibration cycle. The HP 3430A provides 2 readings/second with up to 60% overranging capabilities on all ranges except the 1000 volt range. Input resistance is a constant 10 megohms on all ranges. In-line digital display tubes and the polarity indicator indicate the voltage measurements. The digital display has a storage feature which prevents the display from changing until a new measurement has been taken.

## Voltage ratio option

Three terminal (low side of reference tied to low side of input) ratio is available. The voltmeter indication is then proportional to the ratio of the input voltage (front terminals) and to the reference voltage (rear terminals). A rear-panel slide switch permits either normal or ratio mode operation. When the ratio mode is selected, a front-panel annunciator indicates **RATIO** to minimize the chance of operator error.

## Precision dc amplifier

A precision (0.1%) dc output is available at the rear panel. This amplifier can be used while making measurements, provided the load resistance is 10 k $\Omega$  or greater. Additionally, the output of the amplifier can be used to drive dc recorders.

## Specifications Voltmeter

**Ranges:** full scale presentation of  $\pm 100.0$  mV, 1000 mV, 10.00 V, 100.0 V, and 1000 V (plus up to 60% overranging indicated with 4th digit). 1000 V maximum input. Manual range selection with automatic decimal point positioning. Polarity selection and indication automatic.

## Performance rating:

**Voltage accuracy:**  $\pm (1\% \text{ of rdg.} + 1 \text{ digit})$  from 15°C to 35°C on all ranges;  $\pm (0.25\% + 1 \text{ digit})$  from 0°C to 15°C and 35°C to 50°C on all ranges.

**Stability:** rated accuracy is met after a 10 minute warmup period.

The voltage accuracy is guaranteed for three months. Zero stability is better than 25  $\mu\text{V}/^\circ\text{C}$ . Zero should be adjusted if the operating source resistance is  $> 100$  k $\Omega$  on the 100.0 mV range.

**Response time:** input amplifier responds to 99.9% value of a step input in 0.5 seconds.

## Input characteristics:

**Input resistance:** 10 M $\Omega$   $\pm 0.5\%$ .

**Superimposed noise rejection:** 40 dB at 60 Hz, increasing at 12 dB/octave at higher frequencies.

## Isolation parameters:

**Input:** floating; lowside (middle terminal on the front panel may be operated up to  $\pm 500$  V dc with respect to chassis ground 350 V rms).

**Effective common mode rejection:** ratio of common-mode signal to resultant error in readout.

At dc:  $> 90$  dB on 100.0 mV range, decreasing 20 dB per range.

At 60 Hz:  $> 90$  dB on 100.0 mV range, decreasing 20 dB per range.

**DC amplifier:** amplifier output  $\pm 16$  V dc maximum into 10 k $\Omega$  minimum resistance. (Non-inverting voltage gain is 100 on the 100 mV range, decreasing by a factor of 10 on each higher range). Gain accuracy  $\pm 0.1\%$  (15°C to 35°C)  $\pm 0.15\%$  (0°C to 15°C and 35°C to 50°C).

## Operational features:

**Polarity selection.** Automatic.



**Display storage:** continuous reading. No computation blink.

**Sampling rate:** fixed at 2/second.

## Extreme operation conditions:

**Overload protection:** up to  $\pm 1050$  V dc may be applied safely on all ranges except 100.0 mV range, where the limit is  $\pm 700$  V dc.

**Overload indication:** flashing display.

## Ratio Option 01

Ratios from 0.0001:1 to 1000:1 can be measured.

$$\text{Display volts} = \frac{\text{Input volts}}{\text{Reference volts}}$$

Annunciator indicates **RATIO** when rear-panel **NORMAL-RATIO** switch is set to **RATIO**.

## Reference input:

**Range:** 0.8 to 1.2 V either polarity (selected at rear panel) for rated accuracy.

Instrument is usable with reference voltage between 0.2 V and 1.3 volts.

**Input resistance:** 50 k  $\pm 2\%$  for plus reference, 511 k  $\pm 2\%$  for minus reference.

## Front terminal input:

**Range:** 100 mV full scale nominal on lowest range to 1000 V maximum on highest range.

**Polarity:** either, with automatic indication.

**Input resistance:** 10 M $\Omega$  on all ranges.

## Accuracy:

$\pm (0.15\% \text{ of reading} + 1 \text{ digit})$  15°C to 35°C.

$\pm (0.30\% \text{ of reading} + 1 \text{ digit})$  from 0°C to 15°C and 35°C to 50°C.

## Maximum correct indication:

1333 for reference inputs between 1.0 and 1.2 V.

1599 for reference inputs between 0.8 and 1.0 V.

## General

**Power:** 115 or 230 volts  $\pm 10\%$ , 50 to 1000 Hz, approximately 20 watts.

**Dimensions:** 6-3/32" high, 7-25/32" wide, 11" deep (155 x 190 x 279 mm).

**Weight:** net: 9.75 lbs (4.39 kg); shipping: 12 lbs (5.4 kg).

**Price:** HP 3430A, \$595.

HP 3430A, option: 01, \$675.

**VOLTAGE, CURRENT,  
RESISTANCE**



## DIGITAL VOLTMETERS

Interchangeable plug-ins increase versatility  
Models 3439A/3440A

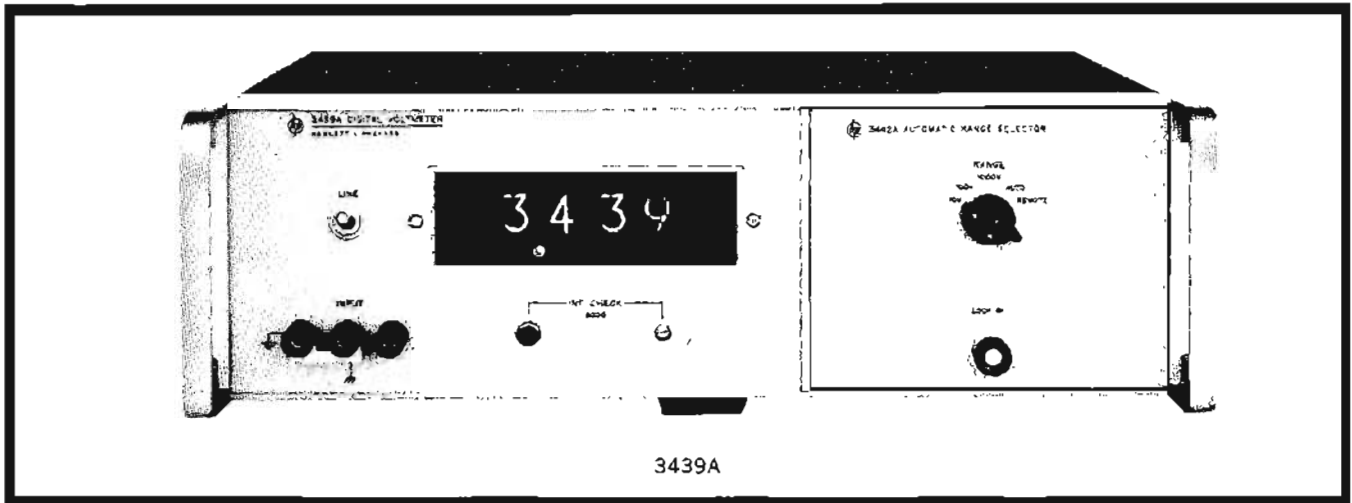

### Interchangeable Plug-ins Increase Voltmeter Versatility

The HP Models 3439A and 3440A are compact, accurate, rapid and multiple-function digital voltmeters. The choice of automatic ranging, remote and manual operation is obtained by using the 3441A, 3442A, 3443A, 3444A, 3445A or 3446A plug-ins, which are interchangeable with any 3439A or 3440A. The basic voltmeter is solid-state with easy-to-service plug-in circuit cards mounted in the Hewlett-Packard modular enclosure.

DC voltages up to 999.9 V of either polarity are displayed in four significant digits with an accuracy of better than  $\pm 0.05\%$  of reading  $\pm 1$  digit and with the polarity of the applied signal indicated automatically. Modes of range selection available for the plug-ins include manual, remote and automatic. Refer to Table 1 for data. The bright, easy-to-read display reduces operator fatigue. Readout storage is another feature of the 3439A and 3440A with large rectangular digital display tubes which display the previous reading, changing only if the input voltage changes. A polarized light filter reduces the reflection of external light so that a good contrast results when the digits are lighted.

#### Accuracy and Speed

The 3439A and 3440A Digital Voltmeters have a dc accuracy of better than  $\pm 0.05\%$  of reading  $\pm 1$  digit over the ambient temperature of  $+15^{\circ}\text{C}$  to  $+40^{\circ}\text{C}$  with a line voltage variation of  $\pm 10\%$ . In addition, specified accuracy is retained to 5% beyond full scale, a feature that permits 5-digit resolution at the decade range change points. The ac input filter has a rejection of 30 dB at 60 Hz and the response time to a step change is 450 ms to read 99.95% of final value without a range change.

The input signal pair may be floated up to 500 V above chassis ground without affecting accuracy. An additional feature which results in high accuracy is the constant 10.2 megohm impedance. This impedance presents a constant load on all voltage ranges.

#### Plug-in Units

Figure 1 illustrates the features obtained by using the

3441A, 3442A, 3443A, 3444A, 3445A or 3446A plug-ins with any 3439A or 3440A.

Plug-in function chart						
Plug-in*	3441A	3442A	3443A	3444A	3445A	3446A
AC volts 10 V to 1000 V	**	**	**	**	✓	✓
DC volts 10 V to 1000 V	✓	✓	✓	✓	✓	✓
DC volts 100 mV to 1000 V			✓	✓		
DC amps				✓		
Ohms				✓		
Manual ranging	✓	✓	✓	✓	✓	✓
Auto-ranging		✓	✓		✓	
Floating input	✓	✓	✓	✓	✓	✓
Remote ranging		✓	✓		✓	✓
Remote function						✓

\*3439A and 3440A require a plug-in to operate.  
\*\*Average response measurements: 100  $\mu\text{V}$  to 300 volts, 50 Hz to 500 kHz use HP 457A; 1 mV to 300 volts, 10 kHz to 10 MHz with HP 400 E/EL. True rms measurements: 1 mV to 300 volts, 10 Hz to 10 MHz, use HP 3400A.

Figure 1. Plug-in Function Chart.

#### BCD Recorder Output (3440A only)

Each of the four digits, with polarity, function and decimal location, is represented by four-line, binary-coded decimal voltages in the 1-2-2-4 weighted code (1-2-4-8 available on special order). The decimal, polarity and the four digits are in parallel-coded form and are completely compatible with the HP 562A Digital Recorder which will print the information in 6 columns.

#### Performance

The operator can instantly verify the accuracy of the 3439A and 3440A by pressing a front-panel button. Typical performance on the 3440A internal calibration source is better than 0.002%/°C TC with stability typically better than  $\pm 0.05\%$  over a 3 month period. The linearity is approximately  $\pm 0.01\%$  for the 10, 100, and 1000 V ranges with 0.03% linearity full scale for the 100 mV and 1000 mV range. The stability of reading is approximately  $\pm 1$  count.



# DIGITAL VOLTMETERS

Interchangeable plug-ins increase versatility  
Models 3439A, 3440A



**VOLTAGE, CURRENT,  
RESISTANCE**

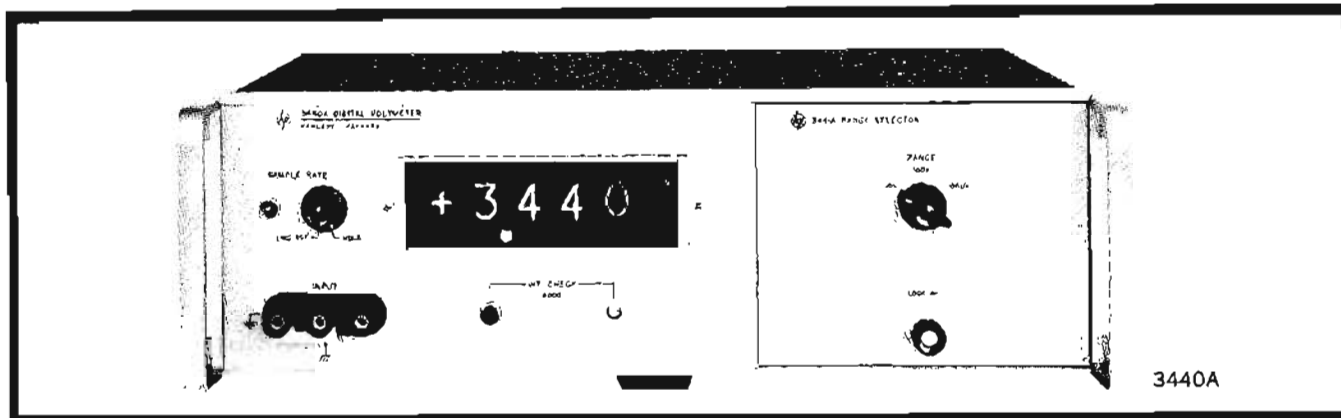

## Specifications

(Main Frame HP 3439A and 3440A)

Model	HP 3440A	HP 3439A
Sample Rate:	5 samples per second to 1 per 5 seconds with storage during samples and "Hold." In "Hold" a sample may be initiated by applying a +10-volt pulse 20 $\mu$ s wide or greater (ac coupled), or by contact closure.	Fixed at between 2 and 3 per second
DC Isolation:	Signal common may be floated up to 500 volts dc from chassis ground.	
Printer Output:	4-line BCD (1-2-2-4) 6 columns consisting of 4 digits of data, polarity, function and decimal. 4-line BCD (1-2-4-8) available on special order. Impedance: 120 k $\Omega$ maximum, each line. "0" state level—24 volts, "1" state level—1 volt.	
Reference Levels:	Positive: approximately -2.5 volts, 330 ohms source impedance. Negative: approximately -27 volts, 920 ohms source impedance.	
Print Command:	Step from -12 volts to -2 volts dc from a 100 ohm source.	
Hold-off Requirements:	Anywhere from +6 volts to +15 volts max. from source impedance less than 2000 ohms. (provided by HP 562A Digital Recorder).	
Remote Triggering:	+10 V pulse 20 $\mu$ s wide or greater, or a contact closure.	
Power:	115 or 230 volts $\pm$ 10%, 50 to 1000 Hz, approximately 20 to 30 watts, depending upon plug-in.	
Weight:	Net, 18 lbs (8 kg); Shipping, 23 lbs (10.35 kg).	
Dimensions:	16 $\frac{3}{4}$ " wide x 5-7/32" high x 11 $\frac{1}{4}$ " deep (425,5 x 132,5 x 285,6 mm).	
Price:	\$1160	\$950

## Accessories Available

HP KOI-3440A Plug-in Extender, \$65.00.  
(HP 3440A Only)

HP J74-562A/AR: Digital Recorder for use with HP 3440A accepting 1-2-2-4 BCD code. (Floating Operation to  $\pm$ 500 V dc.) Includes special print-wheel, 6 BCD column boards, input connector assembly with cable. Cabinet, \$1693; rack, \$1668.

HP J75-562A/AR: Same as J74-562A/AR except for single character function symbol. Cabinet, \$1673; rack, \$1648.

HP J76-562A/AR: Digital Recorder for use with HP 3440A accepting 1-2-4-8 BCD code (Floating operation to  $\pm$ 500 V dc.) Includes special printwheel, 6 BCD column boards, input connector assembly with cable. Cabinet, \$1693; rack, \$1668.

HP J77-562A/AR: Same as J76-562A/AR except for single character function symbol. Cabinet, \$1673; rack, \$1648.

### Note:

If the 3440A is used to drive an HP 562A Printer with a 2nd floating input to the 562A, a special H27-3440A is available. It allows 150 V dc to exist between the 3440A common and the low side of the 2nd input. Up to 500 V dc can exist between the 3440A

common and chassis. Price and delivery will be provided upon request.

Data	Function	Logic 1-2-2-4	Logic 1-2-4-8	Std.	HP 562A Print wheel	
					J75-562A J77-562A	J74-562A J76-562A
0	+ volts	0000	0000	0	+	+V
1	- volts	1000	1000	1	-	-V
2	+ amps	0100	0100	2	A	+A
3	- amps	1100	1100	3	V	-A
4	ac volts	0110		4	~	AC
5	ohms	1110	1010	5	$\Omega$	$\Omega$
6	ac volts		0110	6	~	AC
7	overrange		1110	7	*	**
8				8		
9	overrange	1111		9	*	**

## VOLTAGE, CURRENT, RESISTANCE



## PLUG-INS FOR 3439A/3440A

Interchangeable plug-ins increase versatility  
Plug-in Models 3441A, 3442A, 3443A

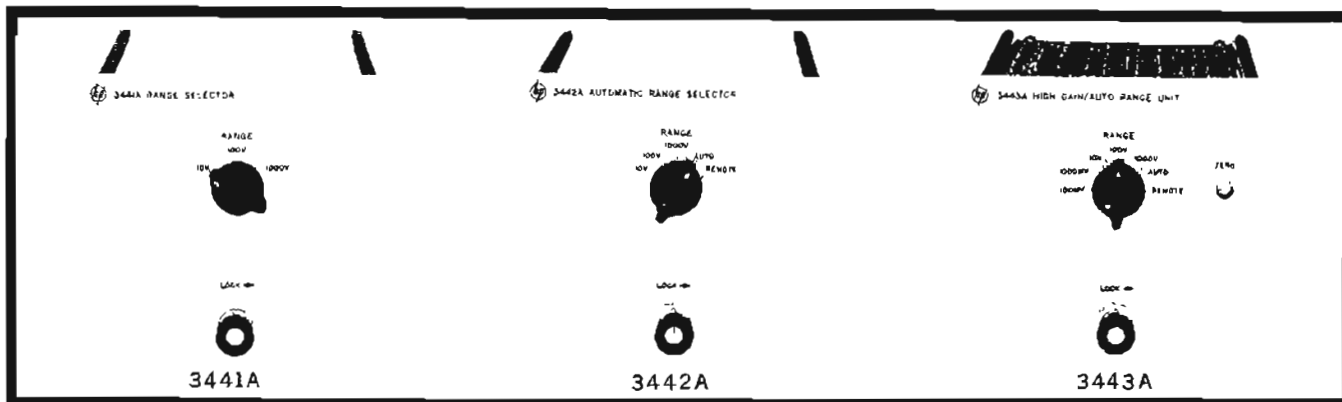

### 3441A Range Selector

The HP 3441A Range Selector is a plug-in unit with a range switch to manually select one of three voltage ranges; 10, 100, or 1000 volts.

### 3442A Automatic Range Selector

HP Model 3442A Automatic Range Selector is also available for use with the 3439A or 3440A Digital Voltmeters. The 3442A retains the manual range selection and adds automatic and remote range features. Ten percent hysteresis is built into the automatic ranging function of the 3442A.

### 3443A High Gain/Auto Range Unit

HP Model 3443A High Gain/Auto Range Unit, available for use with the 3439A or 3440A Digital Voltmeters, features automatic or remote range selection from 100 mV to 1000 volts full scale. A front-panel, zero offset control enables the operator to obtain a zero indication at the DVM to compensate for the thermocouple voltages of external connections. The 3443A has the same ranging capabilities as the 3442A with the additional features of two added ranges and 10  $\mu$ V resolution, making it ideal for thermocouple and transducer measurements.

### Specifications 3441A, 3442A

**Voltage range:** 4-digit presentation of 9.999, 99.99, and 999.9 volts full scale with 5% overrange capability and overrange indicator.

**Voltage accuracy:**  $\pm 0.05\%$  of reading  $\pm 1$  digit including line voltage variations of  $\pm 10\%$  from nominal. A front-panel adjustment on the 3440A insures accuracy over the temperature range between  $+15^\circ\text{C}$  and  $+40^\circ\text{C}$  and  $\pm 0.1\%$   $\pm 1$  digit over the temperature range of  $0^\circ\text{C}$  to  $+15^\circ\text{C}$  and  $+40^\circ\text{C}$  to  $+50^\circ\text{C}$ .

**Range selection:** with 3441A, manual. With 3442A: manual, automatic and remote range change speed. automatic (max.) achieves accurate reading in less than 1 second after new voltage is applied; Remote (max.) will change range with 40 ms.

**Voltmeter input impedance:** constant 10.2 megohms (to dc) all ranges.

**Polarity:** automatic indication.

**Input filter characteristics:** response time; less than 450 ms to a step function to within 99.95% of final value (without a range change).

**Input filter ac rejection:** 10, 100 and 1000 volt ranges: 30 dB at 60 Hz, increasing at 12 dB/octave.

**Weight:**

3441A: net 1 lb (0.45 kg); shipping 4 lbs (1.8 kg).

3442A: net 1.5 lbs (0.7 kg); shipping 4 lbs (1.8 kg).

**Price:** HP 3441A, \$40; HP 3442A, \$135.

### Specifications 3443A

**Voltage range:** 4-digit presentation of 99.99 mV, 999.9 mV, 9.999 volts 99.99 volts, and 999.9 volts full scale with 5% overrange capability and overrange indicator.

**Voltage accuracy:**

9.999 V to 999.9 V full scale:  $\pm 0.05\%$  of reading  $\pm 1$  digit including line voltage variations of  $\pm 10\%$  from nominal. A front-panel adjustment on the 3440A insures accuracy over the temperature range between  $+15^\circ\text{C}$  and  $+40^\circ\text{C}$  and  $\pm 0.1\%$   $\pm 1$  digit over the temperature range of  $0^\circ\text{C}$  to  $+15^\circ\text{C}$  and  $+40^\circ\text{C}$  to  $+50^\circ\text{C}$ .

99.99 mV and 999.9 mV full scale:  $\pm 0.1\%$  of reading  $\pm 1$  digit including line voltage variations of  $\pm 10\%$  from nominal. A front-panel adjustment on the 3440A insures accuracy over the temperature range between  $+15^\circ\text{C}$  and  $+40^\circ\text{C}$  and  $\pm 0.15\%$   $\pm 1$  digit over the temperature range of  $0^\circ\text{C}$  to  $+15^\circ\text{C}$  and  $+40^\circ\text{C}$  to  $+50^\circ\text{C}$ .

**Range selection:** Manual, Automatic and Remote Range Change Speed: Automatic (max.) achieves accurate reading within 1.5 seconds after new voltage is applied; Remote (max.) will change range within 40 ms.

**Voltmeter input impedance:** constant 10.2 megohms (to ac) all ranges.

**Polarity:** automatic indication.

**Input filter characteristics:** (to a step function to within 99.95% of final value without a range change) 10, 100, 1000 V dc ranges; response time  $< 450$  ms. 100, 1000 mV ranges;  $< 1$  second.

**Input filter ac rejection:** 10, 100, and 1000 volt ranges: 30 dB at 60 Hz increasing at 12 dB/octave. 100 and 1000 mV ranges; maximum of 40 mV and 400 mV p-p respectively at 60 Hz for less than 0.1% of full-scale error; allowable ac increasing at 6 dB per octave.

**Weight:** net 3 lbs (1.35 kg); shipping 6 lbs (2.7 kg).

**Price:** HP 3443A, \$450.

## PLUG-INS FOR 3439A/3440A

Interchangeable plug-ins increase versatility

Plug-in Model 3444A



**VOLTAGE, CURRENT,  
RESISTANCE**

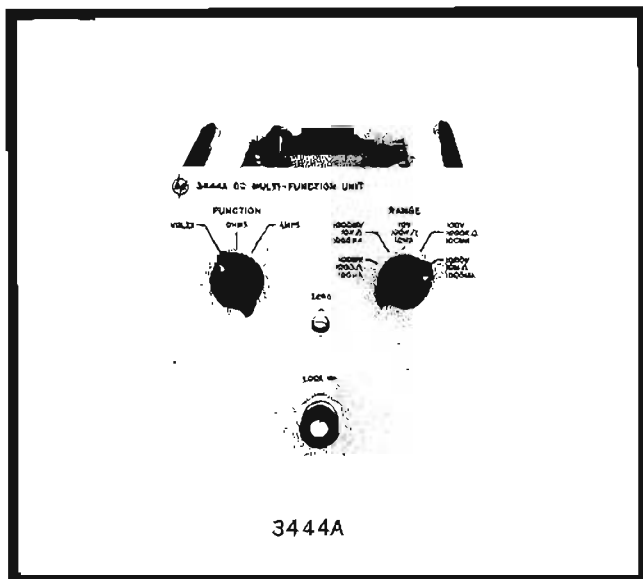

### 3444A DC Multi-Function Unit

The HP 3444A DC Multi-Function Unit, available for use with the 3439A and 3440A Digital Voltmeters, features voltage, current and resistance-measurement capabilities in one plug-in module.

This plug-in offers manual-ranging dc voltage, dc current and resistance measuring capabilities. Full-scale ranges of 100 mV to 1000 V with 10  $\mu$ V resolution make this plug-in ideal for thermocouple and transducer measurements. Full-scale current ranges of 100  $\mu$ A, 1, 10, 100 and 1000 mA are available with a maximum sensitivity of 10 nA. Five resistance ranges of 1000 ohms to 10 megohms are provided.

### Specifications

**Voltage range:** 4-digit presentation of 99.99 mV, 999.9 mV, 9.999 volts, 99.99 volts, and 999.9 volts full scale with 5% overrange capability and overrange indicator.

**Current range:** 4-digit presentation of 99.99  $\mu$ A, 999.9  $\mu$ A, 9.999 mA, 99.99 mA and 999.9 mA with 5% overrange capability and overrange indicator.

**Resistance range:** 4-digit presentation of 999.9 ohms, 9.999 k ohms, 99.99 k ohms, 999.9 k ohms and 9.999 megohms with 5% overrange capability and overrange indicator.

#### Voltage accuracy:

9.999 V to 999.9 V full scale:  $\pm 0.05\%$  of reading  $\pm 1$  digit including line voltage variations of  $\pm 10\%$  from nominal. A front-panel adjustment on the 3440A insures accuracy over the temperature range between  $+15^\circ\text{C}$  and  $+40^\circ\text{C}$  and  $\pm 0.1\% \pm 1$  digit over the temperature range of  $0^\circ\text{C}$  to  $+15^\circ\text{C}$  and  $+40^\circ\text{C}$  to  $+50^\circ\text{C}$ .

99.99 mV and 999.9 mV full scale:  $\pm 0.1\%$  of reading  $\pm 1$  digit including line voltage variations of  $\pm 10\%$  from nominal. A front-panel adjustment on the 3440A insures accuracy over the temperature range between

$+15^\circ\text{C}$  and  $+40^\circ\text{C}$  and  $\pm 0.15\% \pm 1$  digit over the temperature range of  $0^\circ\text{C}$  to  $+15^\circ\text{C}$  and  $+40^\circ\text{C}$  to  $+50^\circ\text{C}$ .

**Current accuracy:**  $\pm 0.2\%$  of reading  $\pm 1$  digit with line variations of  $\pm 10\%$  from nominal.

**Resistance accuracy:**  $\pm 0.3\%$  of reading  $\pm 1$  digit for all ranges up to the 10 megohm range with line variations of  $\pm 10\%$  from nominal.  $\pm 1\%$  of reading  $\pm 1$  digit on the 10 megohm range with line variations of  $\pm 10\%$  from nominal.

#### Ohmmeter current:

Range	Short circuit current
1 k	1 mA
10 k	100 $\mu$ A
100 k	10 $\mu$ A
1 M	1 $\mu$ A
10 M	0.1 $\mu$ A

**Range selection:** manual.

**Voltmeter input impedance:** constant 10.2 megohms (to dc) all ranges.

#### Ammeter input resistance:

Range	Input resistance
100 $\mu$ A	1000 ohms
1000 $\mu$ A	100 ohms
10 mA	10 ohms
100 mA	1.3 ohms
1000 mA	0.4 ohms

**Polarity:** automatic indication.

#### Input filter characteristics:

**Voltage:** less than 450 ms to 99.95% of final value for full-scale step function on 10, 100 and 1000 volt ranges. Less than one sec to within 99.95% of final value for a full-scale step function on 100 and 1000 mV ranges.

**Current:** less than one sec to 99.95% of final value for a full-scale step function on all current ranges.

**Resistance:** 1000 ohms to 1 megohm; less than 1.0 sec to 99.95% of final value. 10 megohms; less than 5.0 sec to 99.95% of final value.

#### Input filter ac rejection:

**Voltage:** 10, 100 and 1000 volt ranges; 30 dB to 60 Hz, increasing 12 dB/octave. 100 and 1000 mV ranges; maximum of 40 mV and 400 mV p-p respectively at 60 Hz for less than 0.1% of full-scale error; allowable ac increasing at 6 dB/octave.

**Current:** p-p ripple current may be up to 40% of full-scale range at 60 Hz for less than 0.1% of full-scale error; allowable ac increasing at 6 dB/octave.

**Weight:** net 3 lbs (1.35 kg); shipping 5 lbs (2.3 kg).

**Price:** HP 3444A, \$575.

# VOLTAGE, CURRENT, RESISTANCE



## PLUG-INS FOR 3439A/3440A

Interchangeable plug-ins increase versatility  
Plug-ins Models 3445A, 3446A

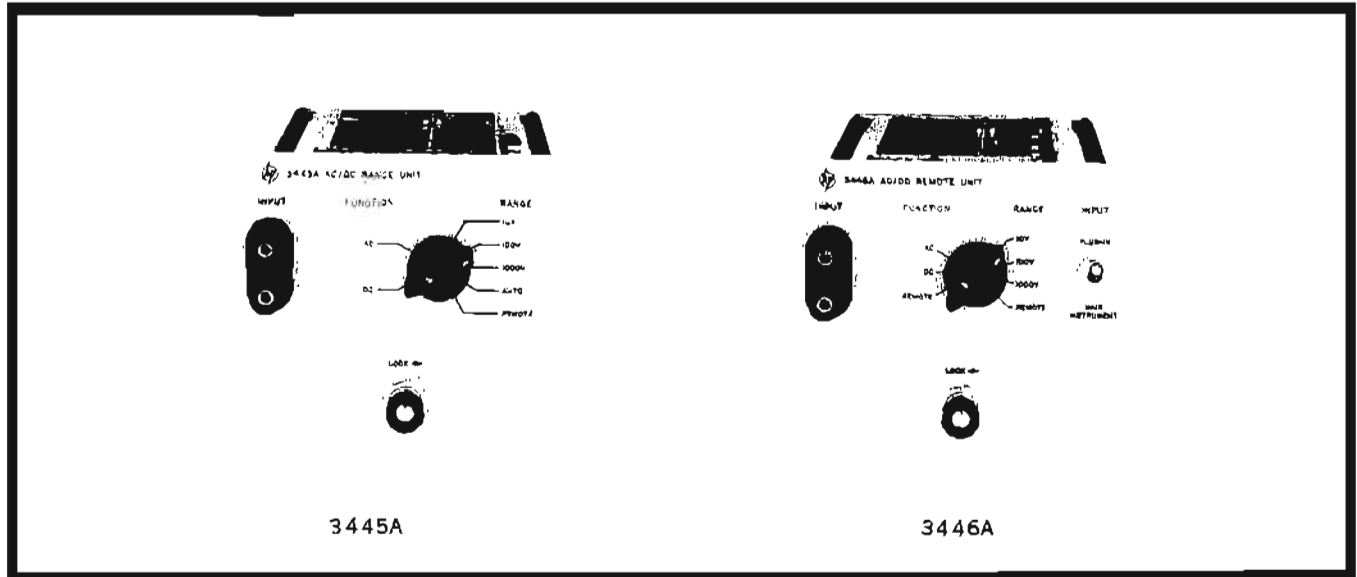

**3445A AC/DC Range Unit**  
**3446A AC/DC Remote Unit**

The HP Model 3445A AC/DC Range Unit or the HP Model 3446A AC/DC Remote Unit may be used with the 3439A or 3440A Digital Voltmeters, for ac or dc measurements. These solid-state units have three full-scale ranges for both ac and dc from 10 to 1000 volts. The ac conversion circuit of the 3445A and 3446A produces a dc output voltage proportional to the average value of the applied ac voltage and is calibrated in rms. The table in the specifications illustrates the differences between the 3445A and 3446A Plug-ins.

Combining the HP 463A Precision Amplifier with the 3445A or 3446A increases the sensitivity of either plug-in from 10 volts full scale to as low as 10 mV full scale over a frequency range of 50 Hz to 100 kHz. Because the HP 463A is a direct-coupled amplifier it can be used to increase the dc sensitivity with any 3441A, 3442A, 3443A or 3446A Plug-in with any 3439A or 3440A Digital Voltmeter. For further information refer to the 463A Data Sheet.

### Specifications

**Voltage range (ac & dc):** 4-digit presentation of 9.999, 99.99, and 999.9 volts full scale with 5% overrange capability and overrange indicator.

**Voltage accuracy (ac):**  $\pm 2$  counts from 20°C to 30°C including line voltage variations of  $\pm 10\%$  from nominal.

#### % Reading % Full Scale Chart

10 V to 1 kV Full Scale	$\pm 0.1$ rdg	$\pm 0.1$ f.s.	$\pm 0.1$ to $\pm 0.3$ linearly derated f.s.
----------------------------	------------------	-------------------	--

	3445A	3446A
Input Terminals	Plug-In only	Plug-in & Main Frame selected by Front Panel Switch
Range selection	Manual, Automatic, Remote	Manual, Remote
Function Selection	Manual	Manual, Remote
Input Impedance (nominal)	10 megohms / 20 pF	Plug-in Input: 10 megohms / 35 pF Main-Frame input: 10 megohms / 175 pF

## INTEGRATING DVM

Precise measurements despite severe noise  
Model 2401C



VOLTAGE, CURRENT,  
RESISTANCE

The 2401C Integrating Digital Voltmeter combines the precision and measurement flexibility of a laboratory instrument with the programming and electrical output features necessary for systems use.

Design features virtually eliminate measurement errors due to extraneous noise superimposed on the signal, without restriction on grounding of the signal source, recorder, or programming device. Signals as small as a few per cent of full scale can be accurately measured even in the presence of noise approaching three times full scale. Controls and input/output features of the 2401C permit maximum versatility of application in an instrument that is simple to use. Programming of the 2401C (for digital systems applications) requires only external circuit closures to ground and does not affect noise rejection properties.

The 2401C measures the average value of the applied voltage over one of three fixed crystal-controlled sample periods (0.01, 0.1 and 1 second), selected manually or remotely. Accuracy is 0.01% of reading +0.005% of full scale +1 digit (at 25°C). Reversing counter circuits permit signals to be integrated around zero with full instrument accuracy. The 6-place display ensures that resolution will not limit a reading.

DC voltages are measured in five ranges from  $\pm 0.1$  V to  $\pm 1000$  V full scale. Range selection is manual, remote or (optionally) automatic. Overranging to 300% of full scale is permissible (all ranges except 1000 V), providing additional resolution and accuracy on the commonly used 1-to-3 readings.

Operation of the optional auto-ranger is extremely fast—3.4 msec maximum range change time. The 2401C with auto-ranging finds excellent application at high sampling rates with varying input signals and at rapid scanning rates when employed in multi-channel systems with widely varying signal levels. The auto-ranger also will select proper range of optional preamp and ac/ohms converter at reduced ranging speeds.

A precision internal standard with stability of  $\pm 0.006\%$  per 6 months (independent of measurement circuit) is included for calibration. An additional mode of operation permits the 2401C to be used for direct frequency measurements up to 300 kHz. Crystal-controlled gate times of 0.01, 0.1 or 1 second can be selected; alternatively, the gate can be opened and closed manually or remotely. For increased accuracy on low-frequency measurements optional period average measurements of 1, 10 or 100 periods of the signal frequency can be made directly in milliseconds.

The 2401C is designed for fully automatic operation within a digital data acquisition system. Measurement function, voltage range, sample period, sampling rate and integration interval all can be selected by external circuit closures to ground. While the measurement circuit of the 2401C is guarded, all remote control lines and electrical outputs are referred to chassis ground and do not interfere with the guard. BCD signals for use with output recorders are produced for each measured digit, for measurement function, voltage range and polarity.

### AC/Ohms measurement

The Model 2410B AC/Ohms Converter enables ac voltages and resistances to be measured with the 2401C and 3460A

Digital Voltmeters. AC voltages up to 750 V peak and resistances up to  $10^7$  ohms are converted to proportional dc voltages between 0 and 1 volt. Optionally, either the ac voltage or resistance converter section may be omitted from the 2410B for applications requiring only one type of measurement.

AC common mode pickup on ac voltage and resistance measurements is virtually eliminated through the use of guarded measurement circuits in the 2410B. However, to obtain the benefits of guarding, the converter must be used with a dc measuring instrument having a guarded input circuit such as the 2401C and 3460A Digital Voltmeters.

Multiple inputs may be applied to the 2410B Converter via a Dymec input scanner. For maximum guarding and/or highest resistance measurement accuracy the 2911 Guarded Crossbar Scanner is recommended; this scanner accepts 200 guarded ac voltage inputs or 100 guarded 4-wire resistance inputs.

### Guarded data amplifier

The 2411A/2401C combination offers a full scale input range of 10 mV with overranging to 30 mV, ideal for measuring outputs of sources such as thermocouples and strain gages. The low zero drift and noise contributed allow excellent accuracy to be obtained in low-level measurements.

The 2411A Amplifier is floated and guarded, thereby preserving the high common mode noise rejection properties of the guarded 2401C Voltmeter when the two instruments are used together. Guarding effectively eliminates the severe errors that would otherwise arise when working with grounded signal sources. The 2411A Amplifier also acts as a buffer. Its input resistance is so high—greater than  $10^{10}$  ohms—that loading of the signal source is negligible.

The amplifier will supply an output of  $\pm 10$  V peak at 1 mA. An overload protection circuit automatically switches the amplifier to the bypass mode if the output exceeds  $\pm 10.5$  V; overloading is indicated by a front panel lamp. The instrument can be reset by a front panel pushbutton or external signal. Inputs up to  $\pm 300$  V peak may be applied to the 2411A without damage. Short-circuiting the output in the +1 and +10 modes has no harmful effect on the amplifier.

The 2411A Amplifier operates directly with the 2401C Digital Voltmeter, and it is furnished with the necessary interconnecting cables. Logic circuitry is included to reposition the voltmeter decimal point automatically when the amplifier is switched to its +10 gain. This convenient feature takes effect on the voltmeter's 0.1 V and 1 V input ranges, and all three sample periods. The voltmeter's recording output is also corrected, precluding the misinterpretation of the recorded data that could otherwise occur. If the amplifier is overloaded in the +10 mode, it will switch automatically to the bypass mode and shift the voltmeter decimal point back to its normal position. The logic circuitry for decimal point positioning is contained on a plug-in card for the voltmeter; this card is furnished with the 2411A Amplifier.

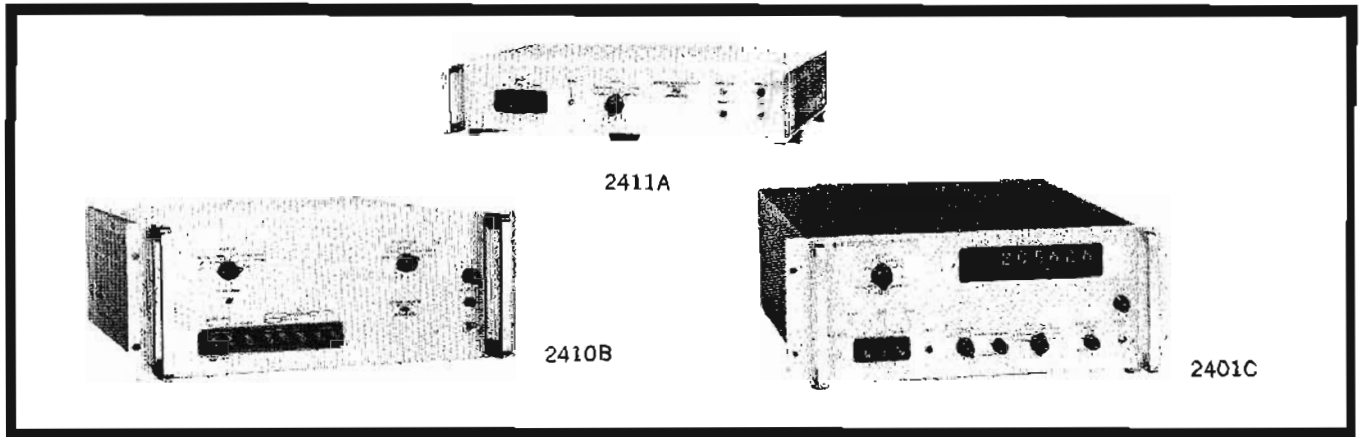

**Specifications, 2401C**

**DC voltage measurements, noise rejection:** overall effective common mode rejection: 140 dB at all frequencies 160 dB at dc (0.1 sec. sample period); common mode rejection: 120 dB at 60 Hz 160 dB at dc, with 1000 ohms between low side of source and low side of input (resistances up to 10 kΩ); superimposed noise rejection: more than 20 dB at 55 Hz for 0.1 sec. sample period, increases 20 dB per decade increase in frequency, infinite rejection at frequencies evenly divisible by 10.

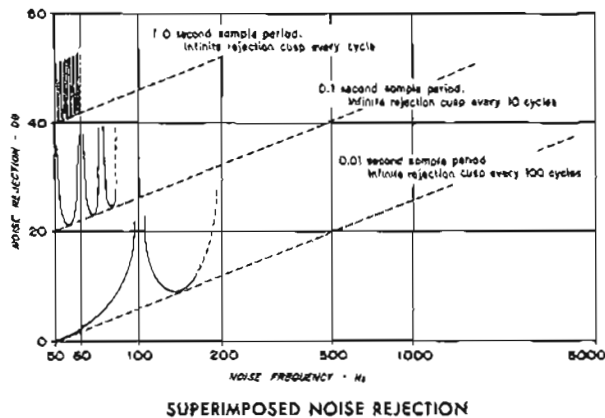

Fig. 1) Superimposed Noise Rejection

**Input circuit:** type: floated and guarded signal pair, may be operated up to 500 V above chassis ground; ranges: 5 from 0.1 to 1000 V f.s., selection by front-panel switch or remote circuit closure to ground, polarity sensed automatically; overranging: to 300% f.s. except 1000 V range; overload: range automatically switched to 1000 V at 310% f.s., reset by next read command; input impedance: 10 MΩ on 1, 100, 1000 V ranges, 1 MΩ on 1 V range, 100 kΩ on 0.1 V range <math>\le 150\text{ pF}</math> all ranges.

**Accuracy:** 0.01% of reading  $\pm 0.005\%$  f.s.  $\pm 1$  digit at 25°C; temperature coefficient 0.001% of reading per °C 10 to 40°C. (calibrated at temperature); 0.0015% of reading 40 to 50°C.

**Internal calibration source:**  $\pm 1$  V standard for self-calibration; stability  $\pm 0.006\%$  per 6 months at 25°C, temperature coefficient  $\pm 0.001\%$  per °C 10 to 40°C; reference derived from specially selected temperature-stabilized zener diode.

**Measurement speed:** fixed sample periods of 0.01, 0.1 or 1 sec. selected by front-panel switch or remote circuit closure to ground.

**Resolution:** depends on sample period; max. 1  $\mu\text{V}$  per digit.

**Auto-ranger (optional) voltage ranges:** automatically selects range from 5 input ranges of standard instrument (0.1 V to 1000 V f.s.) also selects appropriate gain setting (X1 to X10) when 2401C is used with 2411A Amplifier; range change points: up-ranges at 310% f.s., down-ranges at 30% f.s. range select time: 6 msec (nominal) for each range change max. time from receipt of read command to start of sample period 34 msec.

**DC voltage integration:** input signal is integrated over selected sample period; using fixed sample period, integral is average of input, readout in volts; sample period may be started/stopped manually or remotely, display reads in mV sec. or V sec.

**Frequency measurements**

**Range:** 5 Hz to 300 kHz optionally to 1.2 MHz, gate time 0.01, 0.1, 1 sec. or manual; accuracy:  $\pm 1$  count  $\pm$  time base accuracy; time base: stability at constant temperature ( $\pm$  °C) is  $\pm 2/10^6$ /week, temperature effect  $\pm 100/10^6$  over-range 10 to 50°C, provisions for external time base; display time: variable from 0.2 to 7 sec, or held until reset; input sensitivity: 0.1 to 100 V rms or will accept neg. pulses; impedance: 1 MΩ shunted by 150 pF.

**Period measurements**

**Ranges:** 1, 10, and 100 periods; 5 Hz to 10 kHz; display directly in ms; resolution referred to single period: 1 period, 100  $\mu\text{sec}$ ; 10 periods, 10  $\mu\text{s}$ ; 100 periods, 1  $\mu\text{sec}$ ; accuracy is  $\pm 1$  count  $\pm$  time base accuracy  $\pm$  trigger error divided by number of periods. Averaged sensitivity and impedance same as frequency measurements.

**General**

**Display:** 6 digit in-line digital-tube readout; polarity, decimal point, function and overload condition indicated automatically.

**Recording outputs:** BCD output provided for function and polarity, 1 digit; data, 6 digits; decimal point, 1 digit.

**Frequency output:** internal 100 kHz frequency standard available.

**External programming:** may be completely programmed by external circuit closures to ground.

**Operating conditions:** specifications apply for ambient temperatures 10 to 50°C, relative humidity to 95% at 40°C.

**Power:** 115 or 230 V  $\pm 10\%$ , 50 to 60 Hz, 150 W.

**Dimensions:** 19" wide, 7" high, 18 $\frac{3}{8}$ " deep behind front panel (483 x 177 x 467 mm).

**Weight:** net, 48 lbs (22 kg); shipping, 70 lbs (33.5 kg).

**Price:** 2401C, \$3950.

## Specifications 2410B (used with 2401C)

### AC voltage measurements

**Common mode noise rejection:** 110 dB at 60 Hz with 1000 ohms between low side of source and low side of input.

**Input circuit:** frequency range: 50 Hz to 100 kHz voltage ranges: 5 from 0.1 V to 1000 V rms f.s. 1000 V range usable to 750 V peak; overranging to 300% f.s. on all ranges except 1000 V input impedance: 1 M $\Omega$  shunted by 100 pF.

**Output circuit:** output voltage, 1 V dc f.s. into 1 M $\Omega$  load impedance for all input ranges; output resistance, 60 k ohms; response, for frequencies below 400 Hz output settles to within 0.2% of final value in 500 msec. frequencies above 400 Hz output settles to within 0.2% in 200 msec.

**Accuracy:** for  $\pm 10\%$  line voltage change and operating with 2401C when calibrated daily with internal standard. specs hold for 3 months.

Signal Frequency 4.	50 Hz to 10 kHz		10 kHz to 30 kHz		30 kHz to 100 kHz	
Accuracy 1., 2. (At 25°C)	=% rdg	=% fs	=% rdg	=% fs	=% rdg	=% fs
	.10	.05	.20	.06	.30	.10
Temperature Effect 3. (Per °C change from 25°C, 10 to 50°C)	5. .005	—	.01	—	.015	—

- Does not include  $\pm 1$  count display ambiguity, or possible errors from response time or output ripple.
- Overrange accuracy: % fs errors are taken as % rdg and added to existing % rdg error.
- Does not assume calibration of 2401C at operating temperature.
- For steady state accuracy at 30 Hz add .05% rdg. For 20 Hz add .15% rdg.
- .004% with HP 3460A.

### Resistance measurements

**Noise rejection:** resistance measurement circuit enclosed in same guard as ac converter; ac common mode pickup on resistance measurements eliminated by connecting guard to grounded end of test resistance; double-shielded cable allows extension of guard to test resistance.

**Input circuit:** type: guarded modified 4-terminal circuit ranges: 0.1 k, 1 k, 10 k, 100 k, 1 M $\Omega$ , 10 M $\Omega$  f.s.; overranging: to 300% of f.s. on all ranges except 10 M $\Omega$ .

**Output circuit:** output, 1 V dc full scale into 1 M $\Omega$  load impedance for all ranges; output resistance less than 10 ohms on all ranges except 10 M $\Omega$  where it is 100 k $\Omega$ ; response, output settles to 99.995% of final value in 100 msec (for 100 ft. of Dymec resistance measurement cable).

**Accuracy:** specs hold for  $\pm 10\%$  line voltage change and refer to operation with 2401C for 6 months when calibrated daily against internal standards.

At 25°C 1., 2., 3.	=% rdg	=% fs
	.02	.01
Temperature Effect 4. (Per °C change from 25°C, 10 to 50°C)	.005	.001

- Figures do not include  $\pm 1$  count display ambiguity.
- Overrange accuracy: Take % fs error as % rdg, add to existing % rdg error.
- Internal settling delay of 100 ms reduces response error to .005% rdg. This error is included in above figures.
- Figures for operation with 2401C reduce to  $\pm 0.004\%$  rdg  $\pm 0.0005\%$  fs if voltmeter is calibrated at operating temp.

### General

**External programming:** measurement mode (Ohms, DC, AC Normal, AC Fast) and range selected by external circuit closures to ground; commands for 2401C applied to 2410B.

**Programming outputs:** contact closures representing measurement mode and range supplied by 2410B used to program the 2401C.

**Operating conditions:** ambient operating temperatures 10 to +50°C; relative humidity to 95% at 40°C.

**Power required:** 115/230 V  $\pm 10\%$ , 50 to 60 Hz, 110 W approx.

**Dimensions:** 19" wide, 7" high, 17 $\frac{1}{4}$ " deep behind panel (483 x 177 x 438 mm).

**Weight:** net 43 lbs (19.4 kg); shipping 60 lbs (27 kg).

**Price:** 2401B, \$2250, ac only, \$1850; ohms only \$1650.

## Specifications 2411A (used with 2401C)

### Noise rejection

Effective common mode rejection when used with guarded 2401C Digital Voltmeter is 134 dB minimum at all frequencies, 154 dB at dc (0.1 second sample). 2411A reduces common mode rejection of 2401C by less than 6 dB.

### Gain

+1 and +10 (non-inverting). Bypass mode permits use of 2401C to 1000 V. Gain setting and bypass mode selected manually or remotely.

### Accuracy

Accuracy Specifications for 2401C/2411A combination Specifications hold for  $\pm 10\%$  line voltage change; 6 months operation. Assume daily calibration against internal standard; signal source impedance < 100 k $\Omega$ .

## Accuracy specifications for 2401C/2411A combination

Full Scale Input	1 V	100 mV 3.	10 mV 3.				
2401C Range	1 V	0.1 V	0.1 V				
2411A Gain	+1	+1	+10				
Full Scale Readout	Sample Period						
	1 sec	1000.00 mV	100.000 mV	10.0000 mV			
	0.1 sec	1000.0 mV	100.00 mV	10.000 mV			
	0.01 sec	1000. mV	100.0 mV	10.00 mV			
Noise 1. (Does not include $\pm 1$ count display ambiguity.)	Sample Period						
	1 sec	.005 mV	.0015 mV	.004 mV			
	0.1 sec	.02 mV	.005 mV	.001 mV			
	0.01 sec	.1 mV	.025 mV	.005 mV			
Accuracy 2. (At 25°C. Includes noise; does not include $\pm 1$ count display ambiguity.)	Sample Period	=% rdg	=% fs	=% rdg	=% fs	=% rdg	=% fs
	1 sec	.01	.005	.012	.006	.014	.02
	0.1 sec	.01	.005	.012	.01	.014	.03
	0.01 sec	.01	.01	.012	.02	.014	.06
Temperature Effect (Per °C change from 25°C, from 10 to 50°C)	Calibrated at oper. temp.	.0015	—	.0015	—	.0015	—
	Not Calibrated at oper. temp.	.002	.0003	.002	.001	.003	.006

- Reading-to-reading fluctuation from mean value with steady input signal.
- Overrange accuracy: At 2 x fs add % rdg error equal to (.008% - one half % fs error listed).  
At 3 x fs add % rdg error equal to (.014% - one third % fs error listed).
- This combination of voltmeter range and amplifier gain is selected by 2401C Autoranger.

**Zero drift:** 1  $\mu$ V per week, 0.5  $\mu$ V per °C.

**Input circuit:** input resistance: 10<sup>10</sup> ohms for relative humidity to 95% at 40°C; input capacitance: 180 pF nominal; full-scale input.  $\pm 10.5$  V for +1 gain.  $\pm 1.05$  V for +10 gain  $\pm 1000$  V in bypass mode; amplifier automatically switches to bypass when input exceeds these values.

**Output circuit:** max. output:  $\pm 10.5$  V. at 1 ma.

**Setting error:** < 1 count (0.001% of f.s. on 1 sec. gate) with simultaneous application of signal and encode command.

**Programming:** range, selected by external contact closures to ground, selections take < 6 msec; programming output, commands from system scanner routed to voltmeter; generates contact-closures to ground when switched to  $\pm 10$  for correct decimal indication on 2401C.

**Operating conditions:** 10 to 50°C ambient temperature range; up to 95% relative humidity at 40°C.

**Power:** 115 to 230 V  $\pm 10\%$ , 50 to 1000 Hz, 16 W.

**Dimensions:** 16 $\frac{3}{4}$ " wide, 3 $\frac{1}{2}$ " high, 11 $\frac{1}{8}$ " deep behind panel (425 x 88 x 286 mm); hardware furnished to convert to 19" wide rack mount.

**Weight:** net 17 lbs (7.7 kg); shipping 26 lbs (11.7 kg).

**Price:** 2411A \$1200.



**VOLTAGE, CURRENT,  
RESISTANCE**



## DIGITAL VOLTMETER

$\pm 0.004\%$  accuracy, lab precision, systems speed  
Model 3460B

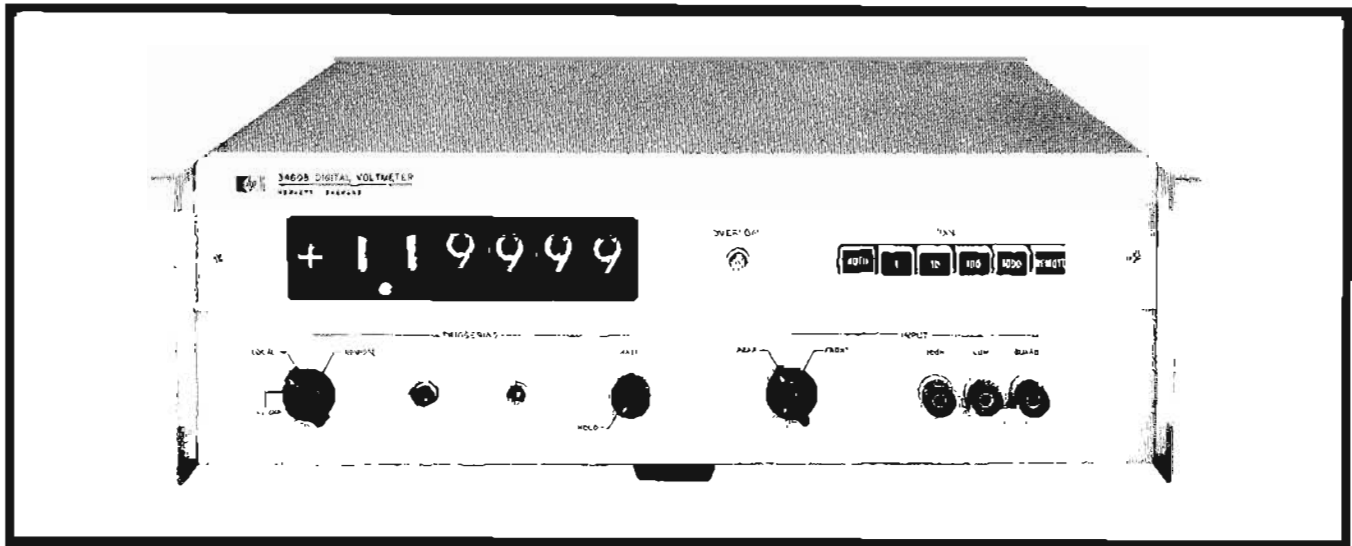

### Description

The new all solid-state Hewlett-Packard 3460B Digital Voltmeter offers a broader measuring capability at moderate cost than any other digital voltmeter available. High accuracy and resolution, high reading rate with more than 5-digit readout and constant high-input impedance are insured with the HP 3460B.

This guarded digital voltmeter permits automatic and remote-controlled dc measurements from 1 V to 1000 V full scale. Low-level measurements of  $\pm 100$  mV can be obtained with 10  $\mu$ V resolution. A high accuracy of  $\pm 0.004\%$  of reading  $\pm 0.002\%$  of full scale makes the 3460B ideal for precision measurements. The HP 3460B provides up to 15 readings per second. 20% overranging on all ranges offers full-scale display within specified accuracy (up to 1200 V on the 1000 V range). Another feature is the choice of constant 10 M $\Omega$  input impedance or  $10^{10}\Omega$  input impedance on the 1 V or 10 V range. In-line digital display tubes and the polarity indicator display voltage measurements from  $\pm 0.00001$  to  $\pm 1199.99$  V dc. These measurements are made with an absolute accuracy of  $\pm 0.004\%$  of reading  $\pm 0.002\%$  of full scale over a temperature range from  $+20^{\circ}\text{C}$  to  $+30^{\circ}\text{C}$  for a period of 90 days. Voltage accuracy temperature coefficient is  $\pm 0.0002\%$  of reading/ $^{\circ}\text{C}$  over a temperature range of  $0^{\circ}\text{C}$  to  $+50^{\circ}\text{C}$ . Four input voltage ranges of 1.00000, 10.0000, 100.000, 1000.00 may be selected by front-panel pushbuttons, automatically or by remote control. A decimal point is automatically positioned so that the display always reads directly in volts.

The HP 3460B is fully programmable. Permanent test records of all readings including polarity, decimal location, function and overload are available with accessory HP Model 562A Printer.

Accessory instruments include the floating and guarded HP 3461A for ac voltage and resistance-measuring capabilities plus a preamplifier offering 1  $\mu$ V dc sensitivity. See page 230.

### Integrating-potentiometric technique

The 3460B is distinctly different from all other types of digital voltmeters. It combines potentiometric and integration techniques and continually measures the true average of the input voltage over a fixed sampling period. It attains  $\pm 0.004\%$  accuracy as a result of the potentiometric technique which makes use of resistance ratios and a stable reference voltage. The use of integration in this combined technique results in much of the superimposed noise immunity of integrating DVM's. The voltmeter, in one 5" high, 19" wide convenient rack-mount unit, combines the extreme precision and measurement flexibility expected from laboratory standards with the programming and electronic output features necessary for automatic systems.

### Programming the 3460B

The HP 3460B is designed for fully automatic operation within a digital data acquisition system. Measurement function, voltage range and integration period can all be selected by external circuit closures to ground.

To simplify system cabling, signal input connections can also be made at the rear of the instrument. All remote-control lines and electrical outputs are referred to the chassis. Grounding the chassis does not affect the floating capabilities of the input lines and guard.

### AC voltage and resistance measurements

AC voltages up to 1200 V rms and resistances to 12 M $\Omega$  can be measured with the 3460B using an HP 3461A AC/Ohms Converter-DC Preamplifier. In addition, the 3461A enables measurements with a constant  $10^{10}\Omega$  input impedance on the 0.1 V, 1 V and 10 V ranges to be made. Insertion of one plug-in board and one function-indicating tube adapts a standard 3460B for use with any 3461A AC/Ohms Converter-DC Preamplifier. When the 3460B is used with the 3461A, complete guarding and signal-pair isolation is maintained. All functions and ranges are manually or remotely programmable; autoranging is offered on all functions. For additional information refer to page 230.

## Specifications

**Ranges:** full scale,  $\pm 1.00000$ ,  $\pm 10.0000$ ,  $\pm 100.000$ , and  $\pm 1000.00$  (up to 20% overranging indicated with 6th digit). Range selection may be made automatically, remotely or manually.

### Performance rating

**Absolute voltage accuracy:**  $\pm 0.004\%$  of reading  $\pm 0.002\%$  of full scale over a temperature range from  $+20^{\circ}\text{C}$  to  $+30^{\circ}\text{C}$  for a period of 90 days.

**Voltage accuracy temperature coefficient:**  $\pm 0.0002\%$  of reading/ $^{\circ}\text{C}$   $\pm 0.0001\%$  of full scale/ $^{\circ}\text{C}$  over a temperature range of  $0^{\circ}\text{C}$  to  $+50^{\circ}\text{C}$ .

**Short-term stability:**  $\pm 0.0025\%$  of reading  $\pm 0.0015\%$  of full scale from  $+20^{\circ}\text{C}$  to  $+30^{\circ}\text{C}$  temperature range and relative humidity up to 50% for a period of 24 hours.

**Long-term stability:**  $\pm 0.008\%$  of reading  $\pm 0.0025\%$  of full scale from  $+20^{\circ}\text{C}$  to  $+30^{\circ}\text{C}$  temperature range and relative humidity up to 50% for a period of 6 months.

**Response times:** fixed range: reads within specified accuracy when triggered coincident with step input voltage. Reading period: 66 ms minimum on 10, 100 and 1000 V range (147 ms minimum on the 1 V range). When filter (optional) is programmed (1 V or 10 V ranges only) an additional delay of 200 ms is added to normal reading period. Polarity selection: no delay. Automatic range selection: 33 ms per range change (100 ms maximum). Remote range selection: 8 ms.

### Input characteristics

**Input resistance:** 10 megohms  $\pm 0.03\%$  during first sample period and full time on 100 V or 1000 V ranges.  $10^{10}$  ohms on second sample period on 1 V or 10 V ranges. Contact closure to ground at rear of 3460B will give constant 10 megohms  $\pm 0.03\%$ .

**Impedance:** 40 pF in parallel with 10 M $\Omega$  at front panel.

**Noise rejection:** overall effective common-mode rejection (ratio of indicated error voltage to common-mode voltage) 145 dB at all frequencies (0.1 sec sample period). Common-mode rejection 160 dB at dc, 120 dB at 60 Hz with 1000 ohms between low side of input and low side of source. Superimposed noise rejection: more than 20 dB at 55 Hz for 0.1 sec sample period (47 dB with optional filter) increased 20 dB per decade of frequency (60 dB/decade with optional filter). Infinite rejection at frequencies divisible by 10 (0.1 sec sample period) or 60 (1/60 sec sample period).

### Isolation parameters

**Inputs:** floated and guarded signal pair (binding post on front panel or connector on rear panel are selected by front-panel switch). Guard may be operated up to  $\pm 500$  V dc with respect to chassis ground (350 V rms). Low may be operated up to  $\pm 50$  V dc with respect to guard.

**Common-mode rejection:** ratio of common-mode signal to resultant superimposed signal: 160 dB at dc with 1 k $\Omega$  between the low side of the input and the point where the guard is connected.  $>145$  dB effective common-mode rejection at all frequencies.

### Input signals

#### Range selection

**Automatic:** pushbutton selector or a switch closure to ground with impedance  $<100$  ohms provides auto range operation. 33 ms is required per range change (100 ms max.).

**Remote:** a switch closure to ground with impedance  $<100$  ohms for a period  $>100$   $\mu\text{s}$  selects range desired.

**Manual:** pushbutton selector.

**External read command:** accepts ac or dc trigger of either polarity.

**Output signals:** print command; dc coupled. BCD outputs; 4-line BCD (1-2-4-8) 9 columns consisting of polarity and function decimal location, overload and 6 digits of data (1-2-2-4 BCD code available as an option).

### Operational features

**Trigger selection:** front-panel selection of local or remote mode.

**Overload Indicator:** indicates when input voltage is higher than 120% of range selected.

**Sampling indicator:** indicates when instrument is digitizing.

### General

**Power:** 115 or 230 V  $\pm 10\%$  50 to 60 Hz, approx. 60 W.

**Dimensions:** 16" wide, 5" high, 21 $\frac{3}{8}$ " deep (127 x 406 x 543 mm).

**Weight:** net 38 lbs (16 kg); shipping 43 lbs (19.6 kg).

**Accessories furnished:** rack mounting kit includes:

Two HP Part #5060-0049 15 pin plug-in, printed-circuit board extender.

One HP Part #5060-0630 22 pin plug-in, printed-circuit board extender.

HP 11065A 6' rear-input cable, guarding preserved, terminated end mates with 3460B.

HP 11085A remote control cable.

**Accessories available:**

HP 3461A AC/Ohms Converter-DC Preamplifier

HP 562A/AR Digital Recorder

**Price:** HP 3460B, \$3600; HP 3460BF, includes optional filter, \$3750

#### Options

01 BCD output (1-2-2-4), no additional charge.

02 Compatible with 3461A AC/Ohms Converter-DC Preamplifier, add \$150.

03 Same as Option 02 with 1-2-2-4 BCD output, add \$150.

## DIGITAL VOLTMETER

Unique new performance at economical price

Model 3459A

### Description

Similar to the 3460B, the HP 3459A provides two readings per second with up to 20% overranging capability on all ranges within specified accuracy. Voltage measurements from  $\pm 0.0001$  to  $\pm 1199.99$  volts dc are made with an absolute accuracy of  $\pm 0.008\%$  of reading  $\pm 0.002\%$  of full scale over a temperature range from  $+20^{\circ}\text{C}$  to  $+30^{\circ}\text{C}$  for a period of 90 days. Voltage accuracy T.C. is  $\pm 0.00025\%$  of reading  $\pm 0.00015\%$  of full scale/ $^{\circ}\text{C}$  over a temperature range of  $0^{\circ}\text{C}$  to  $+50^{\circ}\text{C}$ . Three input voltage ranges of 10.0000, 100.000 and 1000.00 full scale can be selected manually by front-panel pushbuttons or automatically.

**Price:** HP 3459A, \$2850.

#### Options

01 1-2-2-4 BCD output, add \$140.

02 1-2-4-8 BCD output, add \$140.

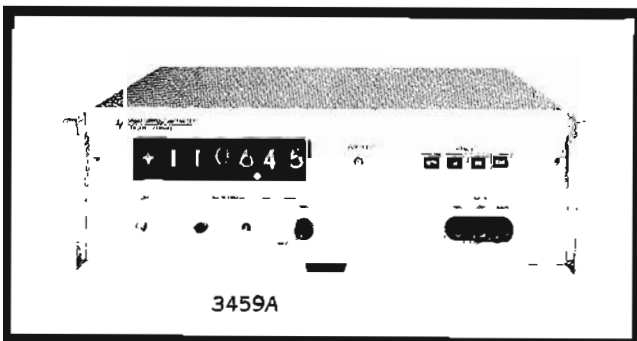

**VOLTAGE, CURRENT,  
RESISTANCE**



**AC/OHMS CONVERTER/PREAMP**  
Automatic ranging in all functions  
Model 3461A

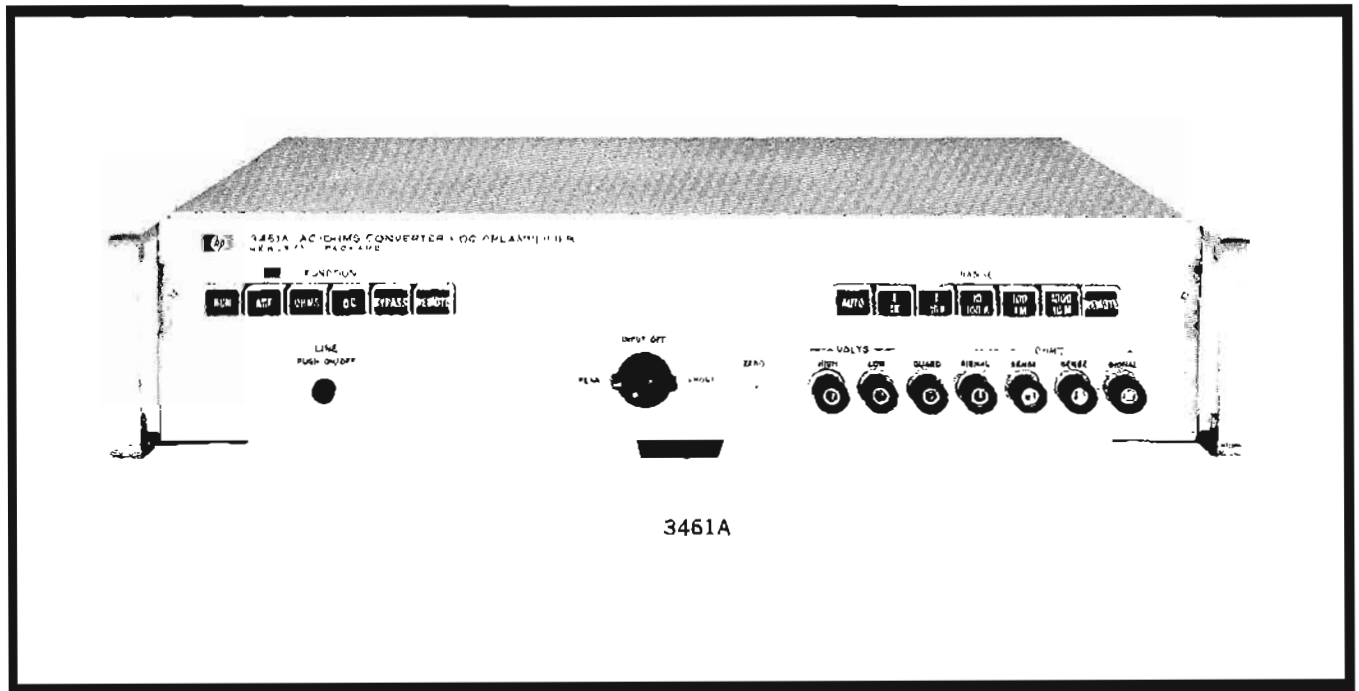

### Description

A new signal conditioning converter, the HP 3461A AC/ohms Converter/DC Preamplifier, now gives the HP 3460B or HP 3460BF the capability of making ac and ohms measurements. A high gain, low noise preamplifier also gives an additional dc range with 1  $\mu$ V resolution. The 3461A features remote range and function programmability, and when used with the HP 3460B/BF allows automatic ranging on all functions and retains guarding, making it an ideal instrument for systems applications. Although the 3461A was designed specifically for use with the 3460B/BF it can also be used with other dc voltmeters.

### Options

The standard HP 3461A includes three measurement capabilities: ac, ohms and dc preamplifier. Other combinations of these features are available on an optional basis. The user may, at his discretion, purchase only one option and add others at a later date, should the need arise. No modifications are necessary—the user may add capability to his 3461A by inserting plug-in, printed-circuit boards and modules.

### AC converter

The ac converter in the HP 3461A is a half-wave, average-responding device, calibrated to the rms value of a sine wave. The converter has two frequency ranges ac fast (200 Hz to 100 kHz) and ac normal (50 Hz to 100 kHz), with four manual, remote or automatic ranges; 1 V, 10 V, 100 V and 1000 V and 20% overrange capability. Its high-input impedance is 5 M $\Omega$  in parallel with 40 pF using the front-input terminals, and 5 M $\Omega$  in parallel with 75 pF when using its rear-input terminals.

### Ohms converter

The HP 3461A Ohms Converter is a 4-terminal ohmmeter. The ohms converter uses a high-input impedance dc amplifier to achieve its ability to measure high resistance with high accuracy. The 3461A has five resistance ranges: 1 k $\Omega$  through 10 M $\Omega$ . It has a capability of 20% overranging and may be operated manually, remotely or automatically.

### DC preamplifier

The DC Preamplifier in the HP 3461A has 10<sup>10</sup>  $\Omega$  input resistance making it possible to measure voltages with high source resistances on the .1 V, 1 V, and 10 V ranges, and resolves 1  $\mu$ V on the .1 V range with no loss in reading rate. The HP 3461A, when used with HP 3460B, allows autoranging over five dc ranges, with fast overload recovery and up to 20% overrange on all ranges.

### Precise ac voltage and resistance measurements

AC voltages up to 1200 V rms and resistances to 12 M $\Omega$  can be measured with the HP 3460B in conjunction with an HP 3461A AC/Ohms Converter/DC Preamplifier. In addition, the 3461A enables measurements with constant 10<sup>10</sup>  $\Omega$  input impedance on the 0.1 V, 1 V and 10 V ranges to be made. All 3460B's are prewired at the factory to convert a standard 3460B DVM to indicate ac/ohms functions when used with the 3461A by insertion of a plug-in, printed-circuit board and one function-indicating tube. When the 3460B is used with the 3461A, complete guarding and signal-pair isolation is maintained. All functions are manually or remotely programmable; autoranging is offered on all functions. Refer to the preceding page for additional information.

## Specifications

### AC to DC Converter

**Ranges:** full scale, 1.00000, 10.0000, 100.000 and 1000.00 V rms (average conversion calibrated in terms of rms). Up to 20% overranging on each range indicated with 6th digit. Range selection may be made automatically, remotely or manually.

**Performance rating** (calibrated to operate into 10 M $\Omega$   $\pm$ 0.1%).

**Absolute voltage accuracy (+20°C to +30°C for a period of 90 days):** 100 Hz—10 kHz,  $\pm$ 0.1% of reading  $\pm$ 0.02% of full scale; 50 Hz—100 Hz and 10 kHz—20 kHz,  $\pm$ 0.15% of reading  $\pm$ 0.02% of full scale; 20 kHz—100 kHz,  $\pm$ 0.25% of reading  $\pm$ 0.10% of full scale.

**Temperature coefficient of accuracy (0°C to +50°C):**  $\pm$ 0.002% of reading  $\pm$ 0.0005% of full scale/°C.

**Long-term stability (+20°C to +30°C for 6 months):**  $\pm$ 0.06% of reading  $\pm$ 0.01% of full scale.

### Ohms to DC Converter

**Ranges:** full scale, 1.00000 k $\Omega$ , 10.0000 k $\Omega$ , 100.000 k $\Omega$ , 1.00000 M $\Omega$  and 10.0000 M $\Omega$ . Up to 20% overranging on each range indicated with 6th digit. Range selection may be made automatically, remotely or manually.

### Performance rating

**Absolute resistance accuracy (+20°C to +30°C for a period of 90 days):** 1.00000 k $\Omega$  to 1.00000 M $\Omega$ ,  $\pm$ 0.008% of reading  $\pm$ 0.002% of full scale; 10.0000 M $\Omega$ ,  $\pm$ 0.012% of reading  $\pm$ 0.002% of full scale.

**Temperature coefficient of accuracy (0°C to +50°C):** 1.00000 k $\Omega$  to 1.00000 M $\Omega$ ,  $\pm$ 0.0005% of reading  $\pm$ 0.0001% of full scale/°C; 10.0000 M $\Omega$ ,  $\pm$ 0.001% of reading  $\pm$ 0.0001% of full scale/°C.

**Long-term stability (+20°C to +30°C for 6 months):**  $\pm$ 0.01% of reading  $\pm$ 0.002% of full scale.

### DC Preamplifier

**Ranges:** full scale,  $\pm$ 0.100000,  $\pm$ 1.00000 and  $\pm$ 10.0000. (Preamplifier may be bypassed on the  $\pm$ 1.00000 and  $\pm$ 10.0000 V ranges.) Up to 20% overranging on each range indicated with 6th digit. Range selection may be made automatically, remotely or manually.

### Performance rating

**Absolute voltage accuracy (+20°C to +30°C for a period of 90 days):**  $\pm$ 0.004% of reading  $\pm$ 0.001% of full scale  $\pm$ 2.0  $\mu$ V.

**Temperature coefficient of accuracy (0°C to +50°C):**  $\pm$ 0.0002% of reading  $\pm$ 0.0001% of full scale  $\pm$ 0.2  $\mu$ V/°C.

**Long-term stability (+20°C to +30°C for 6 months):**  $\pm$ 0.008% of reading  $\pm$ 0.002% of full scale  $\pm$ 2.0  $\mu$ V.

### General

**Response time (when used with 3460B):** reads within specified accuracy when triggered coincident with step input voltage.

### AC fixed range

**AC fast:** 500 ms or 2 readings/sec (200 Hz to 100 kHz bandwidth).

**AC normal:** 1.1 sec or 0.9 reading/sec (50 Hz to 100 kHz bandwidth).

### AC automatic ranging (per range change)

**AC fast:** 400 ms (200 Hz to 100 kHz bandwidth).

**AC normal:** 1.0 sec (50 Hz to 100 kHz bandwidth).

**Resistance, fixed range:** all ranges, 7 readings/sec maximum.

**Resistance, automatic range:** 33 ms per range change.

**DC fixed range:** 10 V range, 15 readings/sec max., 0.1 V and 1 V range, 7 readings/sec max.

**DC automatic range:** 33 ms per range change.

### Input characteristics

**AC front-panel input impedance:** 5 M $\Omega$  in parallel with 40 pF.

**AC rear-panel input impedance:** 5 M $\Omega$  in parallel with 75 pF.

**Resistance input:** 4-terminal.

**DC resistance input:**  $>10^{10}$   $\Omega$  on 0.1 V to 10 V range.

**Selection:** either front or rear input may be selected independently by a front-panel switch.

### Isolation parameters

**Inputs:** floated and guarded. Guard may be operated up to  $\pm$ 500 V dc with respect to chassis ground (350 V rms).

**Common-mode rejection:** 160 dB at dc with 1 k $\Omega$  between the low side of the input and the point where the guard is connected. 120 dB at 60 Hz under the same conditions.

**Programming:** any range or function can be selected by a front-panel pushbutton or remotely by contact closure.

### Output signals

**AC:** 0 to +1.20000 V dc (on all ranges). Output resistance, 200 k $\Omega$   $\pm$ 1%.

**Resistance:** output resistance, 1 $\Omega$ .

Resistance range	Output
1 k $\Omega$ , 10 k $\Omega$ , 100 k $\Omega$ , 1 M $\Omega$	0 to +1.20000 V dc
10 M $\Omega$	0 to +12.0000 V dc
<b>DC:</b> output resistance, 1 $\Omega$ .	
DC range	Output
$\approx$ 0.100000 to $\approx$ 1.00000	0 to $\approx$ 1.20000 V dc
$\approx$ 10.0000	0 to $\approx$ 12.0000 V dc
$\approx$ 100.000	0 to $\approx$ 120.000 V dc
$\approx$ 1000.00	0 to $\approx$ 1200.00 V dc

**Range and function outputs:** the range and function of the HP 3461A are available on the voltmeter programming connector as ten binary-coded lines.

**Operational features:** input terminals; binding posts on front panel or connector on rear panel, selectable by front-panel switch.

**Power:** 115 or 230 V  $\pm$ 10% 50 to 60 Hz, approx. 30 W.

**Weight:** net 24 lbs (10.8 kg); shipping 37 lbs (16.7 kg).

**Dimensions:** 16 $\frac{3}{4}$ " wide, 3 $\frac{3}{8}$ " high, 18 $\frac{3}{8}$ " deep (425 x 87 x 477 mm).

**Price:** HP 3461A, \$2075 (Includes all Options).

**Option 01:** dc preamplifier \$1500.

**Option 02:** ac/dc converter \$1300.

**Option 03:** ohms/dc converter/dc preamplifier \$1700.

**Option 04:** ac/dc converter/dc preamplifier \$1800.

**VOLTAGE, CURRENT,  
RESISTANCE**



## DIGITAL VOLTMETER

DVM resolution,  $1\mu\text{V}$  in 1 V, 1 mV in 1000 V  
Model H04-3460A

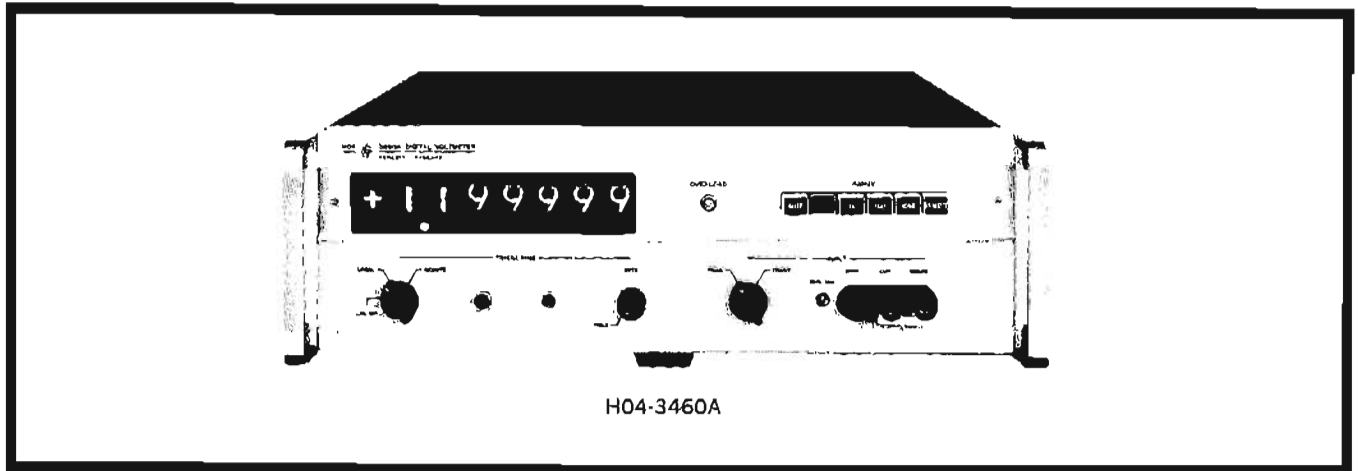

### Features

- Resolution: 1 part in  $1.2 \times 10^6$
- Sensitivity:  $1\mu\text{V}$
- Accuracy: 0.005% of reading
- Guarding reduces the effects of common-mode noise (CMR) by 160 dB at dc
- Four ranges to  $\pm 1000$  volts full scale, selected by push-buttons, automatically or remotely.
- 20% overrange capability on all ranges - offering full-scale display within specified accuracy (measures up to 1200 Vdc).

### Description

The new all solid-state Hewlett-Packard H04-3460A offers a resolution of 1 part in 1,200,000—four times more resolution than any other digital voltmeter in its price range. Additionally, the H04-3460A DVM has a sensitivity of  $1\mu\text{V}$  and an accuracy of 0.005% of reading or  $\pm 0.0005\%$  of full scale. The potentiometric-integrating technique used so successfully in the HP 3460A is also used in the H04-3460A. Using this DVM, measurements from 100 millivolts to 1200 V can be made with better than 0.005% of reading accuracy.

The H04-3460's combination of 1 ppm resolution, high accuracy, constant input impedance, and 20% overranging provide new measurement capabilities. A front-panel zero adjust is provided to compensate for any thermals in connections to external circuitry.

Typical examples where 1 ppm resolution and high accuracy can be used are in semiconductor research and testing and calibration of dc standard power supplies and transfer standards.

Null measurements can be performed with  $1\mu\text{V}$  resolution. BCD output capability permits recording of data and remote programmability permits system applications. Transducers and load cell performance can be monitored for incremental changes in their outputs. Accurate determination of Zener diode breakdown voltages as a function of temperature can be made by utilizing the excellent short-term stability of the H04-3460A.

The H04-3460A offers a maximum reading rate of 1.1 seconds/reading on all ranges. The 20% overranging capability on all ranges offers full-scale display within specified accuracy; up to 1200 volts on the 1000 volt range.

Another feature is the constant 10 megohms impedance on all ranges. Four input ranges of 1.000000, 10.00000, 100.0000, and 1000.000 may be selected by front-panel pushbuttons with automatic or remote control left to the option of the operator. The front-panel input terminals are gold-flashed binding posts to reduce thermal electric effects. The front or rear-guarded input terminals may be selected by a front-panel switch. A decimal point is automatically positioned so that the display reads directly in volts. The H04-3460A is fully programmable. Permanent test records of all readings including polarity, decimal location and overload are available by using HP Model 562A printer. The H04-3460A is designed for fully automatic operation with digital acquisition systems.

### Accurate Measurements

The figure below illustrates accuracies the H04-3460A can achieve compared to the best high-accuracy, 5-digit DVM's available.

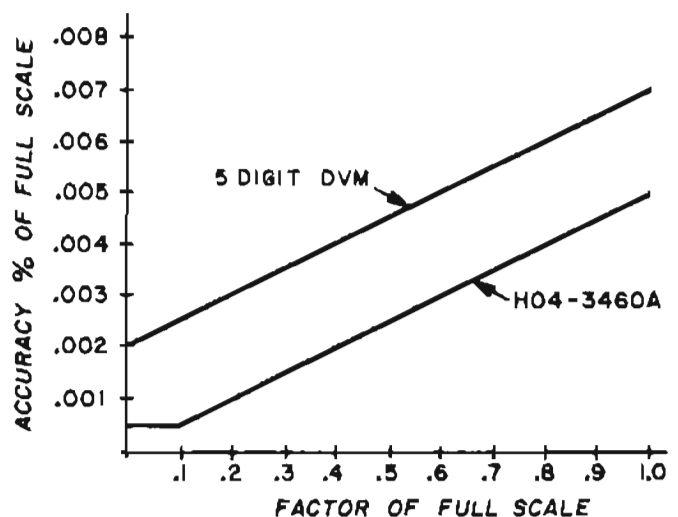

## Programming the H04-3460A

The HP H04-3460A is designed for fully automatic operation within a digital data acquisition system. Voltage range can be selected by external circuit closures to ground.

To simplify system cabling, input connections can also be made at the rear of the instrument. All remote control lines and electrical outputs are referred to chassis ground and do not interfere with the guard.

## Recording Output

1-2-4-8\* binary-coded decimal voltages (ground referenced) are produced for each measurement and for indication of measurement function, voltage range and polarity. A complete printed record of the HP H04-3460A output information can be obtained by using an HP Model 562A/AR Digital Recorder.

\*1-2-2-4 available with HP H04-3460A Option 01.

## Specifications

### Ranges:

Full-scale presentation of  $\pm 1.000000$ ,  $\pm 10.00000$ ,  $\pm 100.0000$ , and  $\pm 1000.000$  (up to 20% overranging indicated with 7th digit). Range selection may be made automatically, remotely or manually.

### Performance rating:

**Absolute voltage accuracy.\***  $\pm 0.005\%$  of reading or  $\pm 0.0005\%$  of full scale whichever is greater over a temperature range from  $+20^{\circ}\text{C}$  to  $+30^{\circ}\text{C}$  for a period of 90 days.

**Voltage accuracy temperature coefficient:**  $\pm 0.0002\%$  of reading/ $^{\circ}\text{C}$   $\pm 0.0001\%$  of full scale/ $^{\circ}\text{C}$  over a temperature range of  $0^{\circ}\text{C}$  to  $+50^{\circ}\text{C}$ .

**Short term stability:**  $\pm 0.002\%$  of reading or  $\pm 0.0004\%$  of full scale, whichever is greater at  $23^{\circ}\text{C} \pm 1^{\circ}\text{C}$  and relative humidity up to 50% for a period of 24 hours.

**Long term stability:\*\***  $\pm 0.008\%$  of reading or  $\pm 0.001\%$  of full scale, whichever is greater at  $23^{\circ}\text{C} \pm 1^{\circ}\text{C}$  and relative humidity up to 50% for a period of 6 months.

### Response time:

On Fixed Range—reads within specified accuracy when triggered coincident with step input voltage.

Reading Period—1.1 sec minimum on 1, 10, 100, 1000 volt ranges.

Polarity Selection—No delay.

Automatic Range Selection—60 ms per range change (180 ms maximum).

Remote Range Selection—8 ms.

### Isolation parameters:

**Inputs:** floated and guarded signal pair (special gold-plated binding post on front panel or connector on rear panel are selected by front-panel switch). Guard may be operated up to  $\pm 500$  V dc with respect to chassis ground (350 volts rms). Low may be operated up to  $\pm 50$  V dc with respect to guard.

**Noise rejection:** overall effective common mode rejection: 160 dB at all frequencies; common mode rejection: 160 dB at dc, with 1000 ohms between low side of input and the point where guard is connected; superimposed noise rejection: more than 43 dB in the vicinity of 50 Hz increases 20 dB per decade increase in

frequency, infinite rejection at frequencies evenly divisible by 10.

### Input characteristics:

**Input resistance:** constant 10 megohms  $\pm 0.03\%$  all ranges.

**Input Impedance:** 40 pF in parallel with 10 megohms at front panel.

### Input signals:

#### Range selection:

Automatic: pushbutton selector or a switch closure to ground.

Remote: a switch closure to ground (storage).

Manual: pushbutton selector.

**External read command:** four lines available for remote trigger (two ac and two dc).

### Output signals:

**Print command:** dc coupled.

**BCD outputs:** 4-line BCD (1-2-4-8) 9 columns consisting of polarity, overload and decimal location, and 7 digits of data (HP H04-3460A Option 01 is available for 1-2-2-4 BCD).

### Operational features:

Input terminals—binding posts on front panel or connector on rear panel (high, low and guard). Selectable by front-panel switch.

Trigger selection: front-panel selection of local or remote.

Overload indicator: indicates when input voltage is higher than 120% of range selected.

Sample indicator: indicates when instrument is digitizing.

### General

**Power:** 115 or 230 volts  $\pm 10\%$ , 50 to 60 Hz. Approximately 60 watts. The HP H04-3460A is available on special order for operation with power line frequencies between 50 and 1000 Hz.

**Dimensions:** 5" high, 16" wide, 21 $\frac{3}{8}$ " deep (127 x 406 x 543 mm); rack mount kit furnished with instrument.

**Weight:** net 38 lbs (16 kg); shipping 48 lbs (21,6 kg).

### Accessories furnished:

Rack Mounting Kit includes 3 printed circuit extender boards.

HP 11065A: 6' rear input cable, guarding preserved, terminated end mates with H04-3460A. \$15.

HP 11069A: Remote Control Cable. \$20.

**Price:** HP H04-3460A, \$4250; Option 01, \$4250.

\*Relative to the National Bureau of Standards.

\*\*Assumes occasional zero adjust.

## VOLTAGE, CURRENT, RESISTANCE



## AC TO DC CONVERTERS

Economical AC to DC Converters

Models 457A, 400E, 3400A

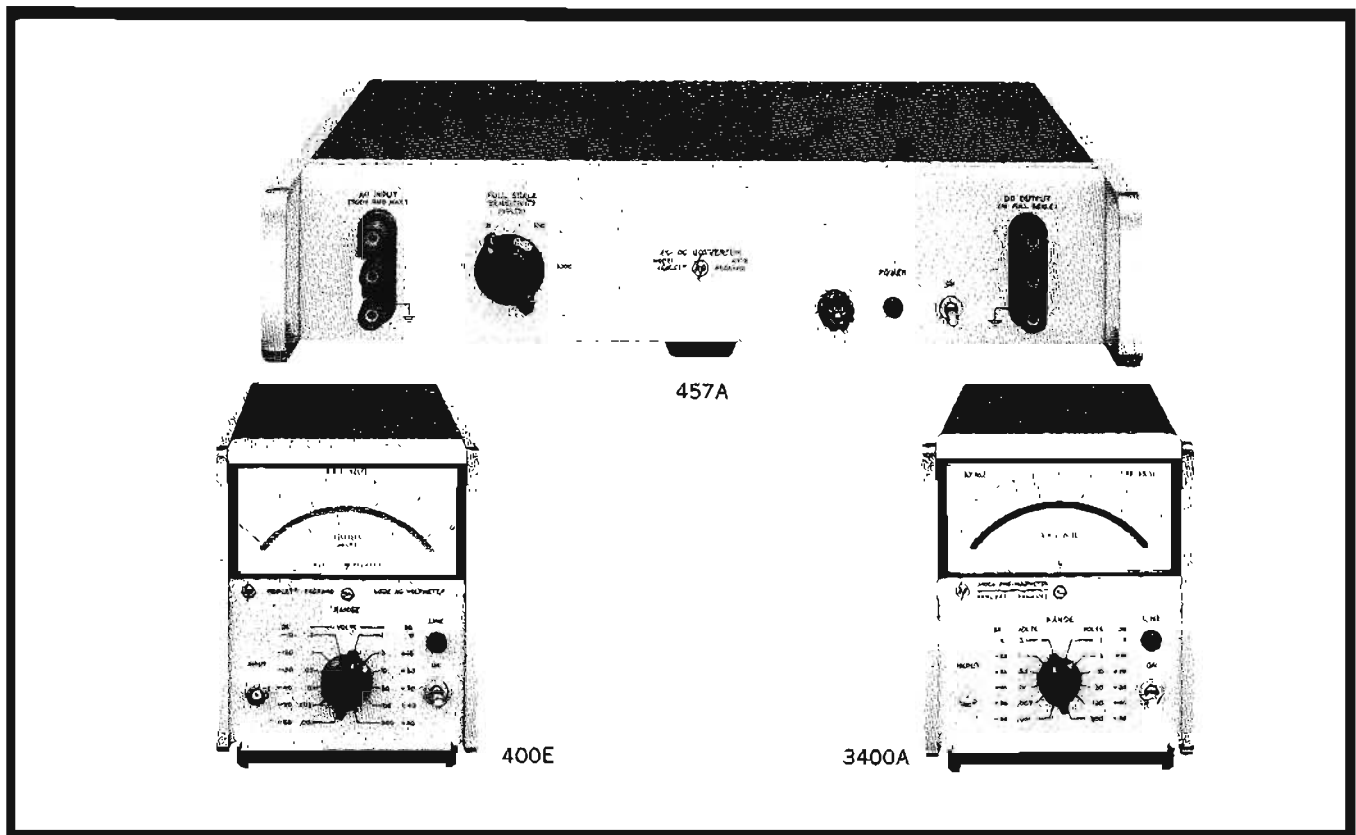

Model 457A is an average-responding, rms calibrated ac-to-dc converter. Thus, a one-volt rms sine wave input provides a one-volt dc output.

A frequency range from 50 Hz to 500 kHz is covered with conversion accuracy of  $\pm 1 \text{ mV} \pm 0.75\%$  of full scale; from 50 Hz to 50 kHz, accuracy is  $\pm 1 \text{ mV} \pm 0.3\%$  of full scale.

### Specifications, 457A

**Input range:** 100  $\mu\text{V}$  to 300 V rms, in 4 decade ranges corresponding to 1, 10, 100 and 1000 V rms full scale; over-ranging to 200% of full scale, all ranges except 1000 V.

**Frequency range:** 50 Hz to 500 kHz.

**Accuracy:**  $\pm 0.3\% \pm 1 \text{ mV}$  from 50 Hz to 50 kHz;  $\pm 0.75\% \pm 1 \text{ mV}$  from 50 kHz to 500 kHz.

**Floating input:** permits measurement of ac voltages at dc potentials of  $\pm 500 \text{ V}$  above power-line ground.

**Output:** 0 to 1 Vdc, responding to average value of ac input, with output calibrated as rms value of sine wave; input step attenuation of 1, 10, 100 or 1000.

**Output impedance:** 10,000 ohms.

**Input impedance:** 1 megohm, shunted by 30 pF.

**Power:** 115 or 230 V  $\pm 10\%$ , 50 to 1000 Hz, approx. 31 W.

**Dimensions:** 16 $\frac{3}{4}$ " wide, 3 $\frac{3}{4}$ " high, 13 $\frac{3}{4}$ " deep (426 x 95 x 324 mm).

**Weight:** net 12 lbs (5.4 kg); shipping 20 lbs (9 kg).

**Accessories available:** 1110A Current Probe, \$100; 10100B Feed-Through Termination, \$17.50; 11000A Cable, \$4.50; 11001A Cable, \$5.50.

**Price:** HP 457A, \$450.

Two Hewlett-Packard analog voltmeters provide a dc output voltage that is directly proportional to the meter current and may be used as ac-to-dc converters. By connecting a dc digital voltmeter to the dc output of these instruments, an economical ac digital voltmeter is available. The output voltage of the HP 400E/EL and 3400A is 1 Vdc for full-scale deflection.

The HP 3400A may be used as a true rms ac/dc converter. Typical dc output accuracy is  $\pm 0.75\%$  of full scale from 50 Hz to 1 MHz. For additional information, refer to page 196.

The 400E/EL may be used with 0.5% accuracy as an ac/dc converter in its frequency range from 100 Hz to 500 kHz. For complete specifications, refer to page 188.

### AC/DC Converter Output

**400E/EL output:** 1 Vdc at full-scale deflection, proportional to meter deflection (linear output for Models 400E/EL).

**Output resistance:** 1000 ohms.

**Response time:** 1 second to within 1% of final value for a step change.

**Price:** HP 400E, \$285; HP 400EL, \$295.

**3400A output:** -1 Vdc at full-scale deflection, proportional to meter deflection (from 10 - 100% of full scale).

**Output resistance:** 1000 ohms.

**Price:** HP 3400A, \$525.



## V-TO-F CONVERTER

Accurate bipolar, low-level dc V-to-F conversion  
Model 2212A



**VOLTAGE, CURRENT,  
RESISTANCE**

The HP 2212A is a compact V-to-F converter which is particularly well suited to low-level signal applications. Low input drift and high common mode rejection (120 dB at dc) have been achieved without a chopper by means of differential circuits. Internal feedback circuits provide an output pulse train with a pulse rate directly proportional to the magnitude of an applied dc voltage. The output pulse rate rises linearly and instantaneously from 0 to 100,000 pulses per second as the dc input level is increased from zero to full scale. These techniques combine to provide outstanding linearity, stability and noise immunity.

The output of the HP 2212A, when connected to a Hewlett-Packard electronic counter provides a convenient method of making digital measurements of dc voltages. The converter also provides a polarity signal. The combination of HP 2212A and a Hewlett-Packard counter can be connected directly to a digital printer or through Dymec couplers to digital recording

devices. Computer processing or storage on punched card, punched tape or magnetic tape can then be accomplished.

The converter-counter combination provides integration of dc voltages over any period of time and can therefore be used to read the average of the input over the selected sample period and provide accurate dc measurements in the presence of noise superimposed on the signal. The instrument is applicable, for example, to high-accuracy FM telemetry systems, gas chromatographs, and wide-range coulometric analysis.

The unique modular package with self-contained power supply allows the 2212A to be used in both bench and systems applications. An inexpensive combining case is available to mount 10 instruments side-by-side in only  $5\frac{1}{4}$ " of standard 19" rack panel space.

Other V-to-F converters are available from Dymec to satisfy a variety of speed, accuracy and resolution requirements. Ask for information on the 2210 and 2211.

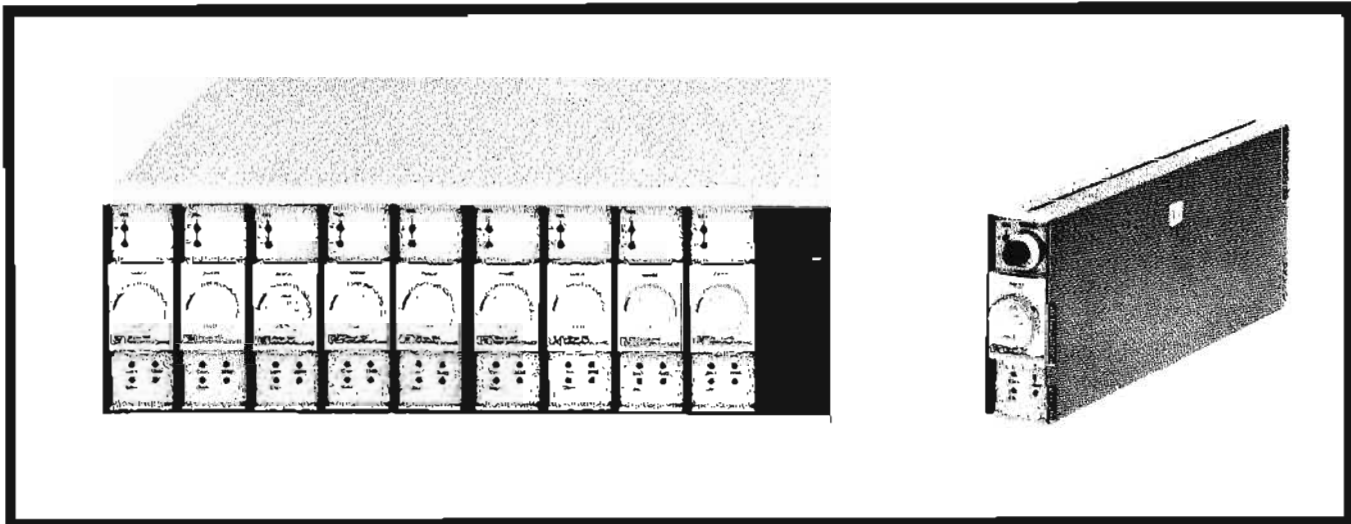

### Specifications

(Unless noted, all specifications apply after a 30-minute warm-up at 25°C ambient, 1 k ohm source resistance, any unbalance).

**Input:** dc voltage ranges: 0 to 10 mV, 100 mV, 1 V; up to 150% overranging; optionally 0 to 10 mV, 30 mV, 100 mV, 300 mV, 1 V; other ranges between 10 mV and 1 V available, up to 6 positions; optional vernier to X3.5 range setting.

**Range accuracy:** (relative to calibrated range):  $\pm 0.02\%$  of reading at 25°C  $\pm 0.005\%$  per month.

**Scale factor:** stability at constant temperature:  $\pm 0.01\%$  of reading per day; temperature coefficient:  $\pm 0.004\%$  of reading per degree C, from 10° to 40°C.

**Zero:** (referred to input): stability at constant temperature:  $\pm \mu\text{V} \pm 0.5 \text{ nA} \pm 0.002\%$  of full scale per day; temperature coefficient:  $\pm 1 \mu\text{V} \pm 0.5 \text{ nA}/^\circ\text{C} \pm 0.001\%$  of full scale per degree C.

**Linearity:**  $\pm 0.01\%$  of full scale (0.01% of reading in over-range) referred to a straight line through 0 and full scale.

**Input impedance:**  $10^9$  ohms min. shunted by 1 nF max.

**Maximum input signal:**  $\pm 11 \text{ V}$  signal + common-mode.

**Common-mode rejection:** 120 dB, dc to 60 Hz.

**Settling time:** 0.1  $\mu\text{sec}$  to within 0.01% of final pulse rate.

**Stewing:**  $10^6 \text{ V/sec}$  rti, for less than 0.1% dc offset.

**Overload recovery:** settling time +100  $\mu\text{sec}$  for differential inputs of 10 times full scale or less, less than 1 millisecc for inputs up to 20 V.

**Output:** pulse train, 0 to  $10^5$  pps full scale; overrange to  $1.5 \times 10^5$  pps; -9 V, 2  $\mu\text{sec}$  pulses.

**Polarity signal:** electrical and visual indication.

**Operating conditions:** 0 to 55°C ambient temperature range, up to 95% relative humidity at 40°C.

**Power:** 115 or 230 V  $\pm 10\%$ , 50 to 400 Hz, 5 W.

**Dimensions:** 1.9/16" wide, 4 7/8" high, 15" deep (39.7 x 123.8 x 381 mm).

**Weight:** net 4 lbs (1.8 kg); shipping 6 1/2 lbs (2.9 kg).

**Accessories available:** combining case contains up to 10 instruments in  $5\frac{1}{4}$ " of standard 19" rack space (mating connectors furnished with amplifier); bench stand, holds one VFC upright and includes input/output connectors, power switch, pilot light, power cord; mating rear connector with power cord, input/output cables.

**Optional modifications:** special voltage ranges; internal calibration source; vernier range adjust.

**Price:** HP 2212A, \$995.



Impedance measurements are concerned with the magnitude and the nature of the opposition of a component or network to the flow of ac current. Not only is a measure of the total opposition to current flow desired, but it is also important to determine the ratio of reactance to resistance and whether the reactance is inductive or capacitive.

At frequencies below 100 MHz, these qualities are most easily determined by measuring the voltage resulting from the flow of a known ac current into the component or network under test. The voltage amplitude indicates the absolute value of the impedance.

The nature of the reactance can be determined by comparing the phase difference between the current and voltage waveforms at the point of measurement. With the magnitude and phase angle  $\theta$  thus determined, the ratio of reactance  $X$  to resistance  $R$  and whether the reactance is inductive or capacitive can be determined (see diagram Fig. 1).

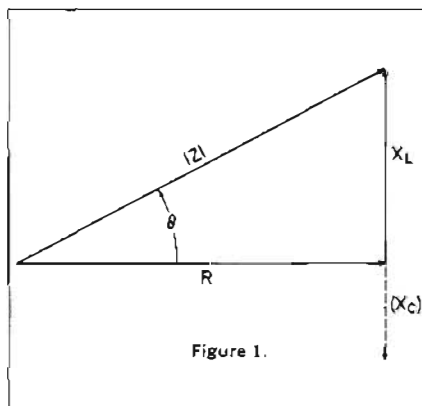

Such measurements must be made at several frequencies if the component or network is to be fully characterized.

In the past, measurements of impedance at RF frequencies and above required several pieces of test equipment and were time-consuming, requiring many steps to acquire the desired information at each discrete frequency. Recently developed instruments from Hewlett-Packard, however, have greatly simplified the measurement of impedance over a broad range of frequencies. With these instruments, it is possible to make sweep frequency plots of the absolute value of impedance  $|Z|$  and phase angle ( $\theta$ ) vs. frequency and in so doing acquire complete coverage within the frequency band of interest.

At frequencies above 100 MHz it becomes more practical to determine impedance by measuring the reflection of an incident signal applied to the device in a coaxial system. Hewlett-Packard has developed Vector Voltmeters and Network Analyzers which make this measurement over a broad range of frequencies, as well as making several other important measurements of interest to the design engineer.

### Vector impedance meters

Direct readout of  $|Z|$  and  $\theta$  are presented on adjacent meters by the remarkable new HP 4800A Vector Impedance

Meter, an internal LC oscillator supplies a low-level excitation signal to the circuit under test through a convenient probe attached to a 5-foot cable. A sampling AGC loop maintains the excitation constant at 4 microamps. At the same time, the voltage response of the test circuit is sensed and converted by a second sampling channel, located within the same probe, to read out directly in impedance. A phase detector monitors the difference between the voltage and current channels to yield the phase angle of the impedance vector. One probe, then, excites the test circuit and measures its impedance and phase angle.

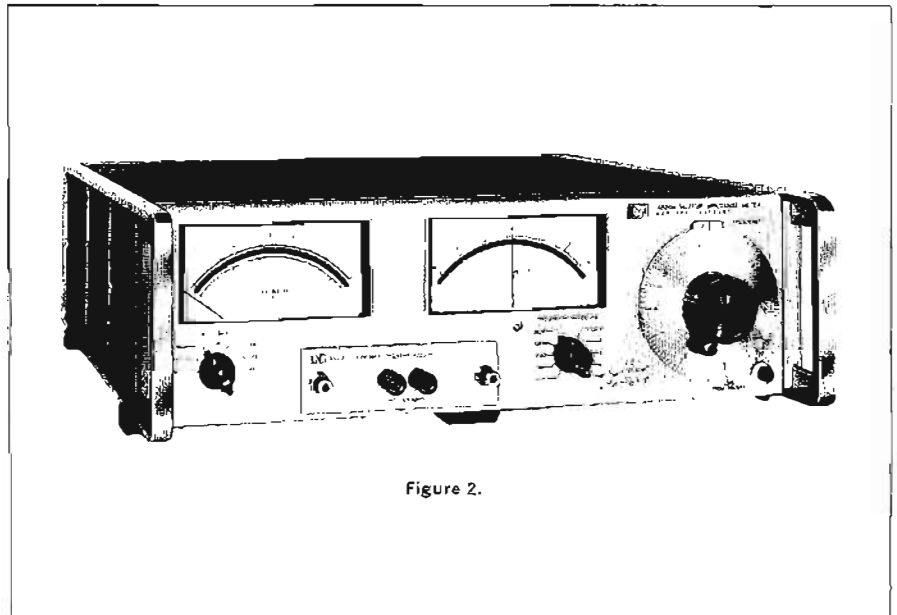

Meter and the HP 4815A RF Vector Impedance Meter.

The 4800A (Fig. 2) which operates in a frequency range from 5 Hz to 500 kHz, requires only that frequency (and range) be selected, as the unknown is connected across front-panel terminals. The magnitude of  $Z$  is read in ohms directly on one meter, while the second meter, centered on zero, indicates phase angle and, by the direction, if the reactance is capacitive or inductive. Optional outputs at the rear provide dc analog signals proportional to meter deflections for  $Z$ ,  $\theta$ , and frequency for convenient recording. The operating range of the Model 4800A is 1 ohm to 10 megohms,  $\pm 90^\circ$  phase angle.

Operating range of the 4815A is 500 kHz to 108 MHz, 1 to 100,000 ohms, 0 to  $360^\circ$  phase angle.

The 4815A provides all of the convenience of "probe and read" measurements. In use, the probe is connected directly into the circuit to be evaluated, frequency is selected, and complex impedance is read. This type measurement allows a straightforward adaptation to various jigs and fixtures for special measurements.

Where only component values are to be determined, a quick-mount adapter is provided to allow rapid measurements. For critical component applications, the unit to be evaluated may be mounted directly in its working circuit and its

value determined in its actual environment, at the frequency of interest.

Analog output of frequency, magnitude, and phase angle are provided so that these values may be recorded on an X-Y recorder.

### Vector voltmeters and network analyzers

Vector Voltmeters measure the amplitude of a signal at two points in a circuit and simultaneously measure the phase difference between the voltage waveforms at the two points. The HP Network Analyzer is similar to the HP Vector Voltmeter in principle but presents the information in the form of gain or loss between the two points, as well as presenting the phase angle.

The Vector Voltmeters/Network Analyzers can be used for a wide variety of measurements, measurements which formerly were difficult and time-consuming in the frequency ranges in which these instruments operate (to 12.4 GHz). Since these instruments can measure the amplitude of a signal at two different points while simultaneously measuring the phase difference between the signals at these points, they are highly useful for making measurements of amplifier gain and phase shift, complex insertion loss, filter transfer functions, two-port network parameters, and many others.

Because signals at UHF and higher frequencies are almost always transferred from point to point on uniform transmission lines, it is entirely practical to use the Vector Voltmeters/Network Analyzers for measuring impedance by determination of the reflection coefficient of a network. This measurement is made using a dual directional coupler to permit measurement of the incident and reflected waves. The reflection coefficient  $\rho$  then gives the magnitude of the input impedance  $Z$  to the device by using the well-known formula:

$$Z = \frac{1 + \rho}{1 - \rho} Z_0$$

where  $Z_0$  is the characteristic impedance of the transmission line. The value of magnitude thus provided and the phase angle measured with respect to a reference are then entered into a Smith chart to determine the complex impedance. The HP Network Analyzer system (page 244) is capable of presenting this information directly as electron beam deflection in a CRT that has a Smith chart overlay for direct readout of impedance.

The Model 8405A Vector Voltmeter is a dual-channel RF millivolt meter and phase meter. It reads the absolute voltages on either of two channels and also the phase relation between them simultaneously. Its frequency range is 1 to 1000 MHz.

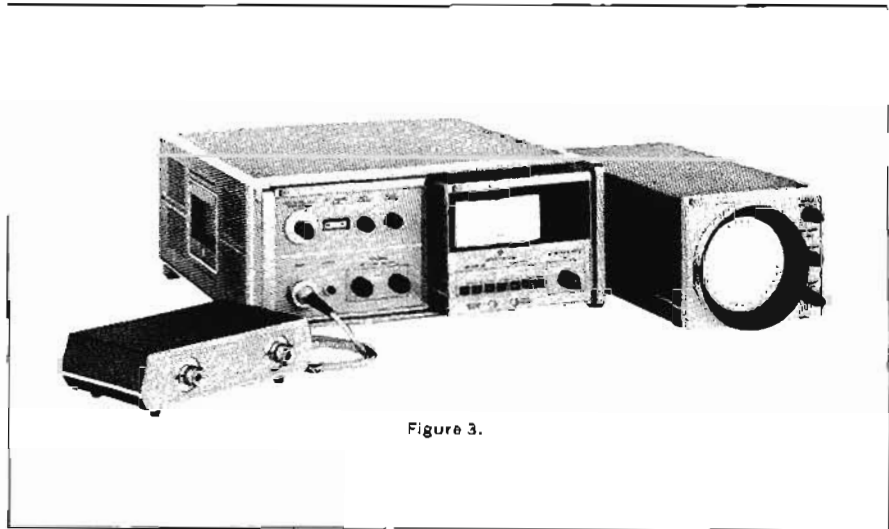

Figure 3.

The Model 8410A Network Analyzer (Fig. 3), and its associated display plug-ins and accessories, also measures magnitude and phase relation between two channels but does so over a frequency range of 100 to 12,400 MHz. It has the capability of displaying these parameters over any octave range between 100 and 12,400 MHz even when swept at a speed as fast as 10 milliseconds.

Plug-in display units for the 8410A provide for measurement of the ratio difference between two channels directly in decibel units, and also the phase shift between these two channels. The readout is directly on a meter face or from output jacks calibrated in units of dB/volt and degrees/volt. The output jacks can be connected to an oscilloscope for a direct visual display of these parameters versus frequency.

Another plug-in display unit has a cathode-ray tube with appropriate polar conversion circuitry to convert the magnitude and phase information to polar coordinates for display on the CRT. A Smith chart overlay is provided for automatically displaying impedance over a wide frequency range.

The 8405A and 8410A are compact instruments housed in standard Hewlett-Packard module cabinets only 7 inches high. This small size has been realized

by the use of sampling techniques for conversion of the RF or microwave frequencies to a lower intermediate frequency. The very wide frequency ranges of these two instruments have also been made possible because of this sampling technique.

These instruments use an automatic phase lock tuning system so that the instruments need only a semi-manual, non-critical adjustment for tuning. For the 8405A, manual tuning consists of selecting any of the 21 overlapping ranges which encompass the input signal frequency; the automatic tuning system then locks to the signal within 10 milliseconds. A front panel light indicates when the unit is locked and operating. Frequencies outside an octave range can be quickly locked in by a quick twist of a knob.

Essentially the same technique is used for the 8410A. A front panel meter indicates the proper position of the coarse frequency control when the unit has automatically locked to the band of frequencies to which the 8410A has been coarsely tuned.

The phase and amplitude measurements are easily read on meters, or, in the case of the 8410 Swept System, directly in calibrated parameters on an oscilloscope face.

From 1 to 1000 MHz the 8405A is con-

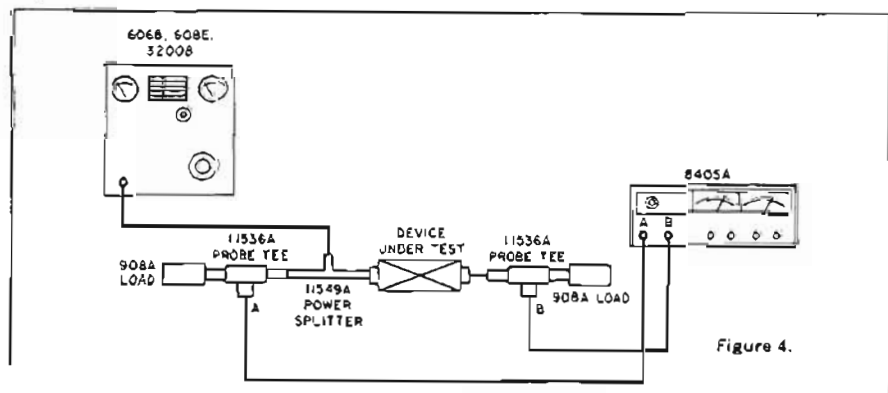

Figure 4.



venient for measuring the phase shift between any two ports. Figure 4 is a block diagram showing the setup of the instrument for this measurement. The setup is first calibrated for a phase reference of 0 degrees by connecting the probe tee of Channel B to the power splitter. Then the device under test is placed between the two components and phase relation is read directly on the phase meter of the

Measurements of phase shift from 110 to 12,400 MHz can be made with the 8410A Network Analyzer. With this instrument, measurements can be made on a swept-frequency basis for a visual oscilloscope or X-Y recorder display.

Figure 5 shows a block diagram of a setup for a typical phase measurement. An accessory transmission unit, the 8740A, is a combination power

plug-ins, 8691 through 8694.

### Impedance

Impedance measurements with these two models are also very easy to make. From 1 to 1000 MHz the Vector Voltmeter can be used as shown in the setups in Figures 7 and 8. In Figure 7, the measurement is made by using probes to sample both the incident and reflected voltages from the device under test. Probe A will sample the incident voltage and probe B the incident plus reflected voltages. The transformation to impedance from reflection coefficient can be made using  $Z/Z_0 = \frac{1 + \rho}{1 - \rho}$ . The measured data on Channels B and A can be entered on a Smith Chart to read impedance directly. A special slide rule is available from Hewlett-Packard to transfer the vector  $1 + \rho$ , which is measured on Channel B, directly onto the Smith Chart.

Between 100 MHz and 1 GHz, impedance measurements can be made by measuring reflection coefficient directly from a dual directional coupler.

Channel A measures the incident voltage and Channel B measures reflected voltage from the device under test. Reflection coefficient is the measurement of  $\frac{B}{A}$  in magnitude; phase is read directly on the phase meter. The system is first

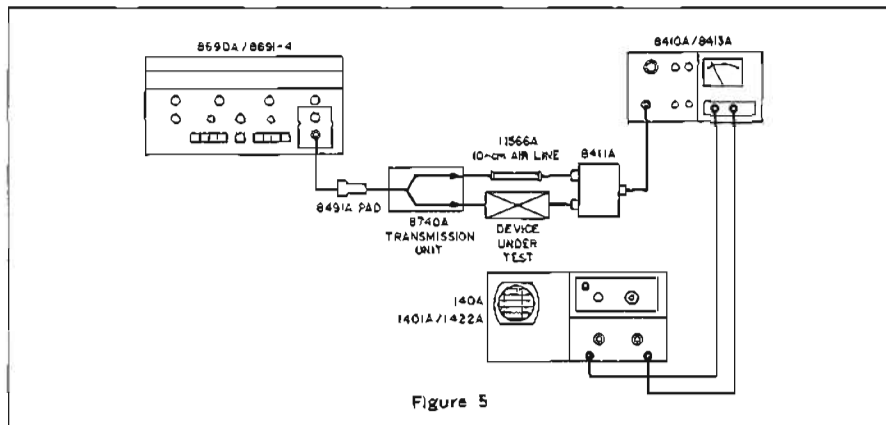

Figure 5

8405A. Any frequency between 1 and 1000 MHz can now be quickly inserted into the device and the reading made within seconds. Absolute voltage will be read directly on Channel A and B and the calculation of gain or loss can be quickly made.

splitter and line stretcher. Initial calibration is performed by connecting both outputs of the 8740A transmission unit directly into the 8411A Harmonic Frequency Converter. A phase reference of 0 degrees is set on the 8413A Phase-Gain Indicator. The device under test is then

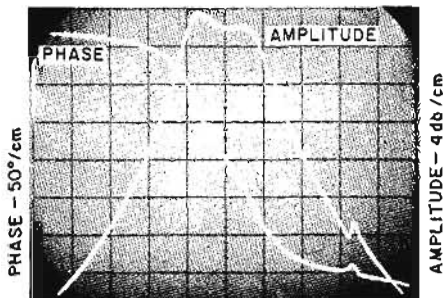

Figure 6

The phase meter has ranges of  $\pm 180$ ,  $\pm 60$ ,  $\pm 18$ , and  $\pm 6$  degrees ranges. A meter offset switch from 0 to  $\pm 180$  degrees in precise 10 degree steps allows any angle to be read on the highest sensitivity range,  $\pm 6$  degrees. This yields a resolution of 0.1 degree on the meter for any angle.

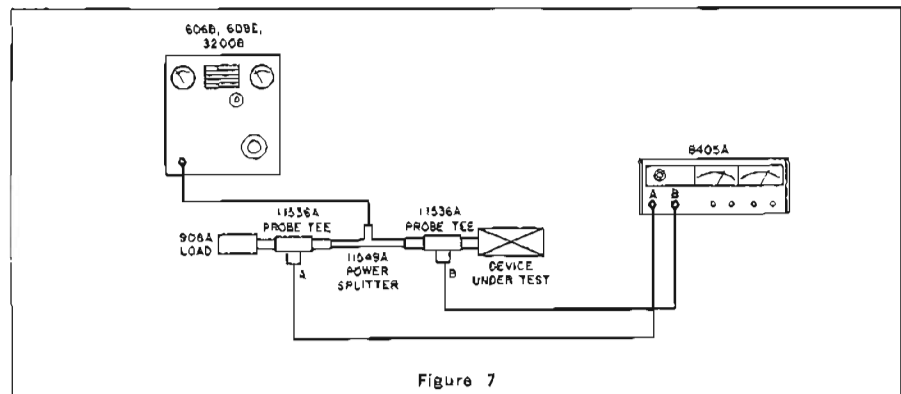

Figure 7

placed in the test channel output of the 8740A and the measurement of phase is made directly on the phase indicator or on swept display basis on an oscilloscope.

Figure 6 shows an oscillogram of the phase shift through a YIG filter, as measured with the system in Figure 5, RF sweep oscillators are also available from Hewlett-Packard to cover the frequency range from 1 to 12.4 GHz. These are the models 8690A Sweep Oscillator with RF

calibrated with a short which sets up a reference reflection coefficient of  $1 \angle -180^\circ$ . The magnitude and phase of the reflection coefficient of the unknown is then read. This can be plotted on the Smith Chart so that impedance may be read directly.

An example of such a measurement is shown in Figure 9. The magnitude is struck off as a vector originating from the center of the Smith Chart. The angle measured on the phase meter is entered

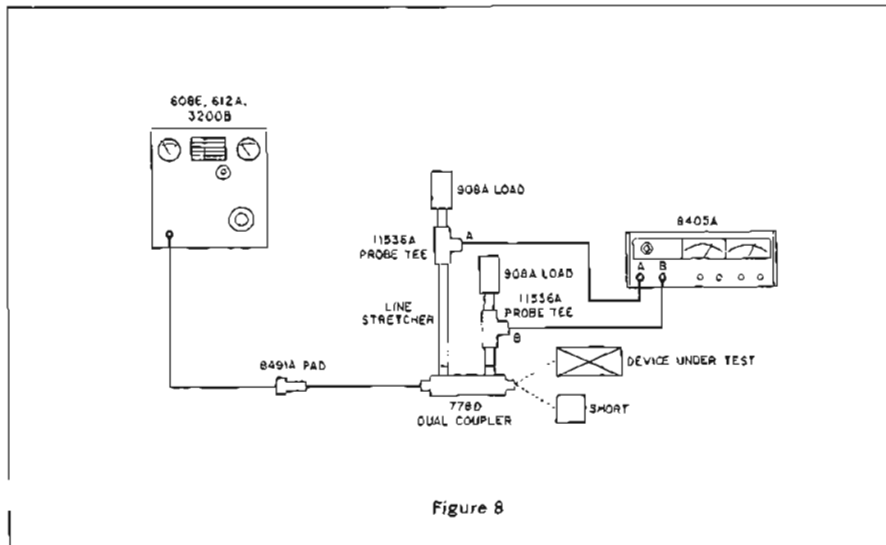

Figure 8

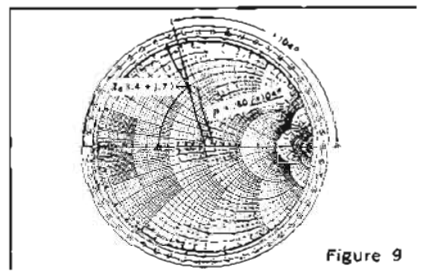

Figure 9

directly on the degree scale on the perimeter of the Smith Chart.

Impedance measurements from 100 MHz to 12,400 MHz are measured automatically on a cathode-ray tube. Figure 10 shows a block diagram and a photo using the 8410A Network Analyzer for this purpose. Two units (Models 8741A, 8742A) are available for measuring the

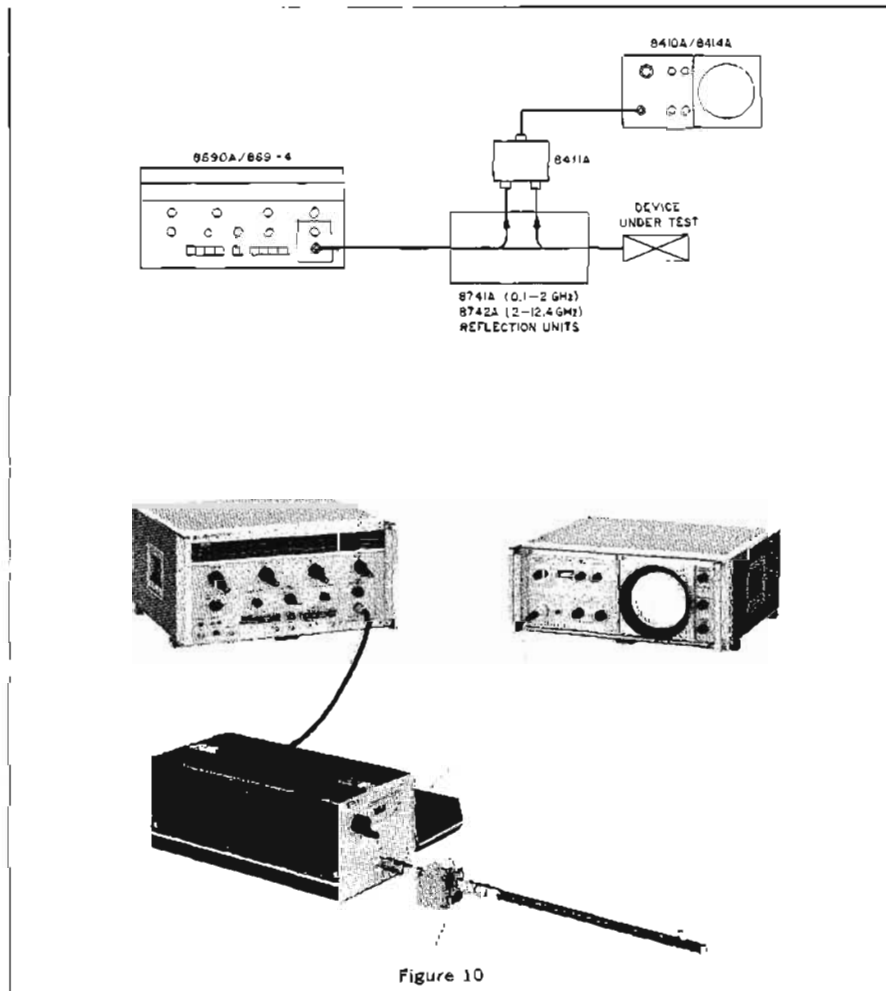

Figure 10

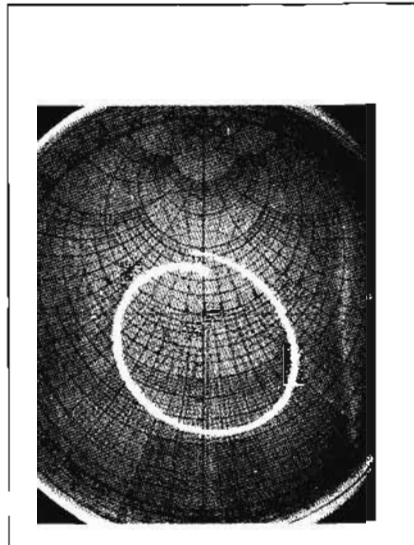

Figure 11.

reflection coefficient of a device with this system.

They cover the range of 0.11 to 12.4 GHz. Again, the reflection coefficient of the device is measured and then converted to a polar display so that it can be read directly on the face of a cathode ray tube in these coordinates. A Smith Chart overlay for the 8414A Polar Display unit allows impedance to be read directly as the frequency is swept. Figure 11 is a typical swept-frequency plot of impedance.

### Scattering parameters

Both the 8405A Vector Voltmeter and the 8410A Network Analyzer are ideally suited for determining scattering, or "s," parameters of two-port networks, with particular reference to transistor characterization. S parameters are more easily measured at frequencies above MHz than the more common h, y, and z parameters because it is more difficult to obtain pure open and short circuits at the higher frequencies. S parameters are measured with the device terminated in 50 ohms. (For a discussion of s parameters and how to use them, see Hewlett-Packard Application Note 77-1 "Transistor Parameter Measurements.")

S parameters are derived from measurements of the forward and reverse transfer characteristics of the device or circuit and of the reflection coefficients looking into both the input and output ports. The 8405A and 8410A determine the complex values of all of these quantities and do so quickly. The design of high-frequency circuits is greatly accelerated by using the Vector Voltmeter or the Network Analyzer to determine the s parameters of components and circuits.

# IMPEDANCE



## VECTOR VOLTMETER

Measures phase, amplitude from 1 MHz to 1 GHz  
Model 8405A

The HP 8405A Vector Voltmeter provides the missing information in rf voltage measurements—PHASE. Since rf voltages are quantities having both magnitude and phase with respect to each other, simple voltage measurements tell only half the story. Most circuit design is virtually impossible without phase information. Both magnitude and phase data is required to define the network parameters needed to optimize design. The HP 8405A allows you to measure, with one instrument, both voltage (magnitude) and phase over the extremely wide frequency range of 1 to 1,000 MHz.

In addition to these unique capabilities, the HP 8405A features high accuracy and resolution, direct readout, and operating convenience. These features enable you to make rf voltage and phase measurements more easily than ever before. By making these measurements simple, the HP 8405A opens the door to new and more effective methods of component, network, and amplifier evaluation. Thus the HP 8405A reduces costs by minimizing equipment requirements, saves time by simplifying measurements, and increases effectiveness by extending capability over a wide frequency range.

### 1-kHz bandwidth, automatic tuning

The HP 8405A is a two-channel tuned volt/phasemeter with a 1-kHz bandwidth. Thus it responds only to the fundamental frequency of the input signal, eliminating errors due to harmonics. Yet, the HP 8405A is as easy to operate as any untuned voltmeter, making it well suited for fast production line testing. You simply rotate a front-panel switch to select any of the 21 overlapping octave ranges which include the input signal frequency, and the automatic phase-locked tuning does the rest. To eliminate guesswork, a front-panel light tells you when the voltmeter is properly tuned. The automatic tuning will follow slowly drifting or swept signals so long as they remain within the selected octave range. In addition, the two-channel input of the HP 8405A allows you to make repetitive voltage measurements at two points in a circuit, to check the effects of adjustments, for example, without altering the setup.

The HP 8405A uses the sampling technique to convert the input rf signals to 20-kHz replicas having the same amplitude, waveform, and phase relationship as the input signals. These 20-kHz signals are then filtered so that only 20-kHz sinusoids remain, and the amplitude of and phase difference between these sinusoids are indicated on front-panel meters.

### 360° phase range, 0.1° resolution

Phase is read on a zero-center meter with end-scale ranges of  $\pm 180^\circ$ ,  $\pm 60^\circ$ ,  $\pm 18^\circ$ , and  $\pm 6^\circ$ . The  $\pm 6^\circ$  scale provides 0.1° resolution, and a meter offset selectable in precise 10° increments permits this resolution to be realized anywhere in the 360° range. Phase accuracy is  $\pm 1.5^\circ$  at fixed frequencies and constant input levels and is quite insensitive to variations in either.

### 100 $\mu$ V fs sensitivity, > 100-dB range

Voltages from less than 100 microvolts to 1 volt can be measured on channel B of the 8405A, from less than 300 microvolts to 1 volt on channel A. (Channel A requires the higher input to operate the automatic tuning.) External 10:1 dividers are supplied to extend the range of both channels to 10 volts. This wide range, plus the selective 1-kHz bandwidth enables you to measure gains or losses in excess of 100 dB simply and accurately. Voltage is read on a single front-panel meter; you select which channel voltage is indicated simply by setting a switch. Both volt and phase meters have rugged, reliable raut-band suspensions with mirror-backed scales individually calibrated to the meter movement.

The input signals are applied through convenient ac-coupled probes which are permanently attached to the instrument. These probes present a high input impedance (0.1 megohm shunted by 2.5 picofarads) for minimum loading effects when probing. The 10:1 dividers increase input impedance to 1 megohm shunted by 2 picofarads. The ac coupling in the probes permits you to measure signals as much as 150 volts off ground. Output signals include the 20 kHz signals from each channel plus recorder outputs proportional to phase and amplitude.

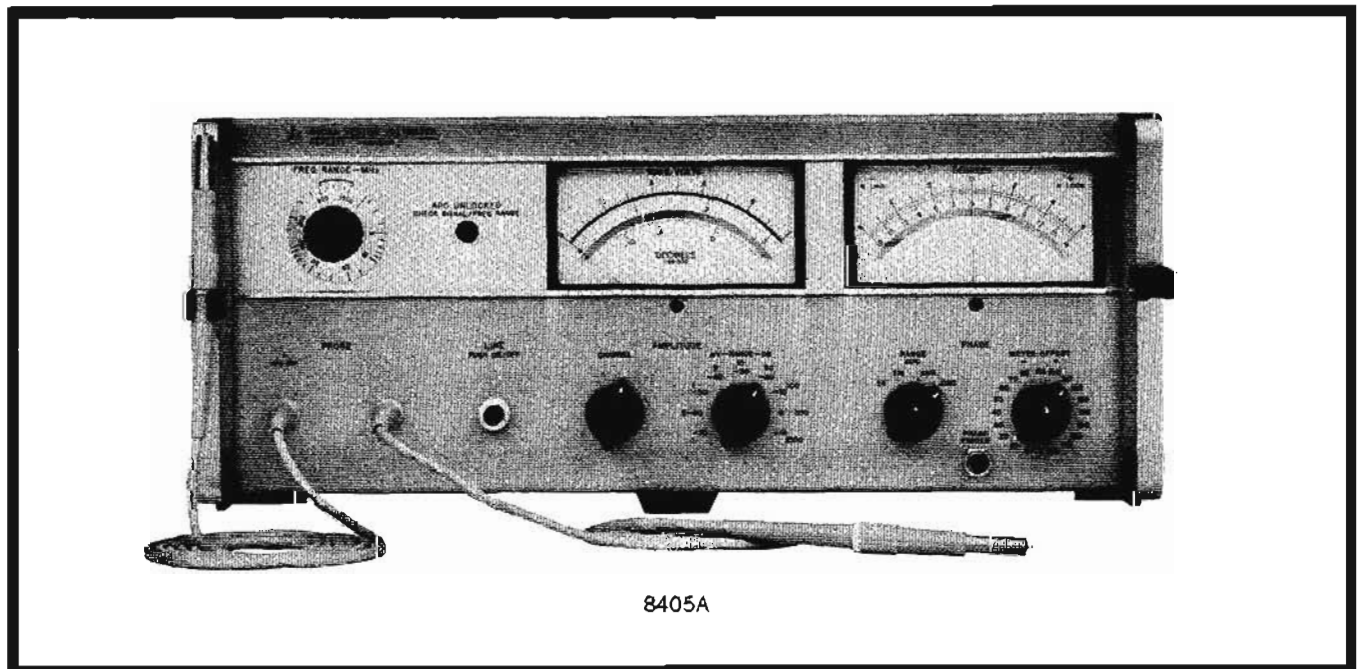

8405A



## Specifications

### Input characteristics

**Instrument type:** two-channel sampling rf millivoltmeter-phasemeter which measures voltage of two signals and simultaneously displays the phase angle between the two signals.

**Frequency range:** 1 MHz to 1 GHz in 21 overlapping octave bands (lowest band covers two octaves).

**Tuning:** automatic within each band; automatic phase control (APC) circuit responds to the channel-A input signal; search and lock time, approximately 10 msec; maximum sweep speed, 15 MHz/sec.

**Voltage range:** channel A: 1 to 10 MHz, 1.5 mV to 1 V rms; 10 to 500 MHz, 300  $\mu$ V to 1 V rms; 500 to 1,000 MHz, 500  $\mu$ V to 1 V rms; can be extended by a factor of 10 with 10214A 10:1 Divider; channel B: 100  $\mu$ V to 1 V rms full scale (input to channel A required); can be extended by a factor of 10 with 10214A 10:1 Divider.

**Input impedance (nominal):** 0.1 M $\Omega$  shunted by approximately 2.5 pF; 1 M $\Omega$  shunted by approximately 2 pF when 10214A 10:1 Divider is used; 0.1 M $\Omega$  shunted by approximately 5 pF when 10216A Isolator is used. AC coupled.

**Isolation between channels:** 1 to 400 MHz, greater than 100 dB; 400 to 1000 MHz, greater than 75 dB.

**Maximum AC input** (for proper operation): 3 V p-p (30 V p-p when 10214A 10:1 Divider is used).

**Maximum DC input:**  $\pm$ 150 V.

### Voltmeter characteristics

**Meter ranges:** 100  $\mu$ V to 1 V rms full scale in 10-dB steps; meter indicates amplitude of the fundamental component of the input signal.

**Voltage accuracy** (at the probes): 1 to 100 MHz, within  $\pm$ 2% at full scale; 100 to 400 MHz, within  $\pm$ 6% at full scale; 400 to 1,000 MHz, within  $\pm$ 12% at full scale; not including response to test-point impedance.\*

**Single-channel tracking accuracy:**  $\pm$ 2% of full scale ( $\pm$ 0.2 dB for Option 02).

**Amplitude range switch accuracy:**  $\pm$ 1%.

**Voltage response to test-point impedance:**\* +0, -2% from 25 to 1,000 $\Omega$ ; effects of test-point impedance are eliminated when 10214A 10:1 Divider or 10216A Isolator is used.

**Residual noise:** less than 10  $\mu$ V as indicated on the meter.

**Bandwidth:** 1 kHz.

### Phasemeter characteristics

**Phase range:** 360 $^\circ$ , indicated on zero-center meter with end-scale ranges of  $\pm$ 180,  $\pm$ 60,  $\pm$ 18, and  $\pm$ 6 $^\circ$ ; meter indicates phase difference between the fundamental components of the input signals.

**Resolution:** 0.1 $^\circ$  at any phase angle.

**Meter offset:**  $\pm$ 180 $^\circ$  in 10 $^\circ$  steps.

**Phase accuracy:** within  $\pm$ 1.5 $^\circ$ , not including phase response vs. frequency, amplitude, and test-point impedance.\*

**Phase response vs. frequency:** 1 to 100 MHz, less than  $\pm$ 0.2 $^\circ$ ; 100 to 1000 MHz, less than  $\pm$ 3 $^\circ$ .

**Phase response vs. signal amplitude:** 1 V to 3 mV rms, less than  $\pm$ 2 $^\circ$ ; 1 V to 100  $\mu$ V rms, less than  $\pm$ 3 $^\circ$  (add an additional  $\pm$ 10 $^\circ$  from 0.1 to 1 V rms between 500 and 1,000 MHz, + for changes affecting channel A only, - for channel B only; effects tend to cancel when signals to both channels change equally).

**Phase response vs. test-point impedance:**\* 0 to 50  $\Omega$ , less than  $\pm$ 2 $^\circ$ ; 25 to 1,000  $\Omega$ , less than -0 $^\circ$ , +9 $^\circ$  for channel A only, less than +0 $^\circ$ , -9 $^\circ$  for channel B only.

**Phase jitter vs. channel B input level:** greater than 700  $\mu$ V, typically less than 0.1 $^\circ$  p-p; 125 to 700  $\mu$ V, typically less than 0.5 $^\circ$  p-p; 20 to 125  $\mu$ V, typically less than 2 $^\circ$  p-p.

### General

**20 kHz IF Output** (each channel): reconstructed signals, with 20 kHz fundamental components, having the same amplitude, waveform, and phase relationship as the input signals; output impedance, 1000  $\Omega$  in series with 2000 pF; BNC female connectors.

**Recorder output:** amplitude: 0 to +1 V dc  $\pm$ 6% open circuit, proportional to voltmeter reading in volts; output tracks voltage reading within  $\pm$ 0.5% of full scale; output impedance 1000  $\Omega$ ; BNC female connector; phase: 0 to  $\pm$ 0.5 V dc  $\pm$ 6%, proportional to phase-meter reading; external load greater than 10,000  $\Omega$  affects recorder output and meter reading less than 1%; output tracks meter reading within  $\pm$ 1.5% of end scale; BNC female connector.

**RFI:** conducted and radiated leakage limits are below those specified in MIL-I-6181D and MIL-I-16910C except for pulses emitted from probes; spectral intensity of these pulses is approximately 60  $\mu$ V/MHz; spectrum extends to approximately 2 GHz; pulse rate varies from 1 to 2 MHz.

**Power:** 115 or 230 V  $\pm$ 10%, 50 to 400 Hz, 35 watts.

**Weight:** net, 30 lb (13.5 kg); shipping 35 lb (15.8 kg).

**Dimensions:** 16 $\frac{3}{4}$ " wide, 7 $\frac{1}{4}$ " high, 18 $\frac{3}{8}$ " deep (425 x 185 x 467 mm); hardware furnished for rack mount 19" wide, 6-31/32" high, 16 $\frac{3}{8}$ " deep behind panel (483 x 177 x 416 mm).

### Accessories furnished:

10214A 10:1 Divider (two furnished) for extending voltmeter range; voltage error introduced is less than  $\pm$ 6% 1 MHz to 700 MHz, less than  $\pm$ 12% to 1 GHz; if used on one channel only, phase error introduced is less than  $\pm$  (1+0.015f/MHz) $^\circ$ , + for channel A, - for channel B. 10216A Isolator (two furnished) for eliminating effect of test-point impedance on sampler;\* voltage error introduced is less than  $\pm$ 6% 1 to 200 MHz, response is 3 dB down at 500 MHz; if used on one channel only, phase error introduced is less than  $\pm$  (3+0.185f/MHz) $^\circ$ , + for channel A, - for channel B.

10213-62102 Ground Clip (six furnished) for 10214A and 10216A.

5020-0457 Probe Tip (six furnished).

10218A BNC Adapter (two furnished) converts probe tip to male BNC connector.

**Accessories available:** 11570A Accessory Kit, includes two 11536A 50 $\Omega$  Tees, one 11549A Power Splitter, two 908A Terminations, one 11512A Type N Male Shorting Plug, and one 11569A Accessory Case, \$318; 11536A 50 $\Omega$  Tee, for monitoring signals in 50 $\Omega$  systems, \$75; 11549A Power Splitter, for evaluating components, \$85; 11569A Accessory Case, convenient for storing accessories, \$8.50; 10503A Cable Assembly, \$6.50; 11512A Shorting Plug, Type N male, \$4.50; 1250-0778 Adapter, both connectors Type N male (UG-57B/U), \$5.50; 1250-0780 Adapter, Type N male and BNC female (UG-201A/U), \$3; 1250-0781 Adapter, Tee, two connectors BNC female, one BNC male, \$5; 10501A 50 $\Omega$  Load, BNC male connector, \$5; 8491A Coaxial Attenuator, 3, 6, 10, and 20 dB, \$50 each.

**Price:** Model 8405A, \$2500.

**Option 01.** Furnished without 10:1 Dividers, less \$35.

**Option 02.** Linear dB scale uppermost on voltmeter, add \$25.

\*Variation in the high-frequency impedance of test points as a probe is shifted from point to point influences the samplers and can cause the indicated amplitude and phase errors. These errors are different from the effects of any test-point loading due to the input impedance of the probes.



**IMPEDANCE****VECTOR IMPEDANCE METER**

Quickly, easily measure  $Z$  &  $\theta$ , 5 Hz to 500 kHz  
Model 4800A

**Advantages:**

- Reads impedance and phase angle directly
- Easy to operate, no balancing or nulling
- Versatile, plug-in measuring terminals
- Reliable, solid-state circuits

The HP 4800A Vector Impedance Meter will make fast measurements of impedance to 10 megohms and phase to  $\pm 90^\circ$  of unknown two-terminal networks. Measurement can be made at a particular frequency or over a continuous range from 5 Hz to 500 kHz. The instrument may be mechanically swept to produce continuous measurements over its full frequency range. Analog outputs of frequency, impedance, and phase are available for X-Y recording. The instrument provides the design engineer with an easy-to-use, one-instrument method for checking components and circuits.

**Specifications****Frequency characteristics**

**Range:** 5 Hz to 500 kHz in five bands: 5 to 50 Hz, 50 to 500 Hz, 0.5 to 5 kHz, 5 to 50 kHz, 50 to 500 kHz.

**Accuracy:**  $\pm 2\%$  from 50 Hz to 500 kHz,  $\pm 3\%$  from 5 to 50 Hz,  $\pm 1\%$  at 15.92 on frequency dial from 159.2 Hz to 159.2 kHz,  $\pm 2\%$  at 15.92 Hz.

**Monitor output:** level: .2 volt rms minimum; source impedance: 600 ohms nominal.

**Impedance measurement characteristics**

**Range:** 1 ohm to 10 megohms in seven ranges: 10 ohms, 100 ohms, 1000 ohms, 10 k ohms, 100 k ohms, 1 megohm, 10 megohms full scale.

**Accuracy:**  $\pm 5\%$  of reading.

**Phase angle measurement characteristics**

**Range:**  $0^\circ$  to  $\pm 90^\circ$ ; **Accuracy:**  $\pm 6^\circ$ ; **Calibration:** increments of  $5^\circ$ .

**Direct inductance measurement capabilities**

**Range:** 1  $\mu\text{H}$  to 100,000 H, direct reading at decade multiples of 15.92 Hz.

**Accuracy:**  $\pm 7\%$  of reading for  $Q$  greater than 10 from 159.2 Hz to 159.2 kHz;  $\pm 8\%$  of reading for  $Q$  greater than 10 at 15.92 Hz.

**Direct capacitance measurement capabilities**

**Range:** 0.1 pF to 10,000  $\mu\text{F}$ , direct reading at decade multiples of 15.92 Hz.

**Accuracy:**  $\pm 7\%$  of reading for  $D$  less than 0.1 from 159.2 Hz to 159.2 kHz,  $\pm 8\%$  of reading for  $D$  less than 0.1 at 15.92 Hz.

**Measuring terminal signal characteristics**

**Wave shape:** sinusoidal.

**Distortion:** less than 1% from 10 Hz to 500 kHz, less than 2% from 5 Hz to 10 Hz.

**Signal level:** less than 2.2 mV rms 1 to 1000 ohms, approx. 20 mV rms 10 k to 100 k ohms, approx. 200 mV rms 100 k ohms to 1 megohm, approx. 2 V rms 1 megohm to 10 megohms.

**Recorder outputs: (available as option 01)**

**Frequency:** level, 0 to 1 volt nominal; source impedance, 0 to 1000 ohms nominal; proportional to frequency dial rotation.

**Impedance:** level, 0 to 1 volt nominal; source impedance, 1000 ohms nominal.

**Phase angle:** level, 0 to  $\pm 9$  volt nominal; source impedance, 1000 ohms nominal.

**Accessories furnished:** 13525A Calibration Resistor, 00610A Terminal Shield.

**Dimensions:** 16 $\frac{3}{4}$ " wide, 5 $\frac{1}{4}$ " high, 16 $\frac{3}{8}$ " deep (426 x 133 x 416 mm).

**Weight:** net 24 lbs (10.8 kg), shipping 30 lbs (13.5 kg).

**Power:** 105 to 125 V or 210 to 250 V, 50 to 400 Hz, 27 W.

**Price:** HP 4800A, \$1,490; Option 01, recorder outputs for  $Z$ ,  $\theta$ , and frequency, \$100.

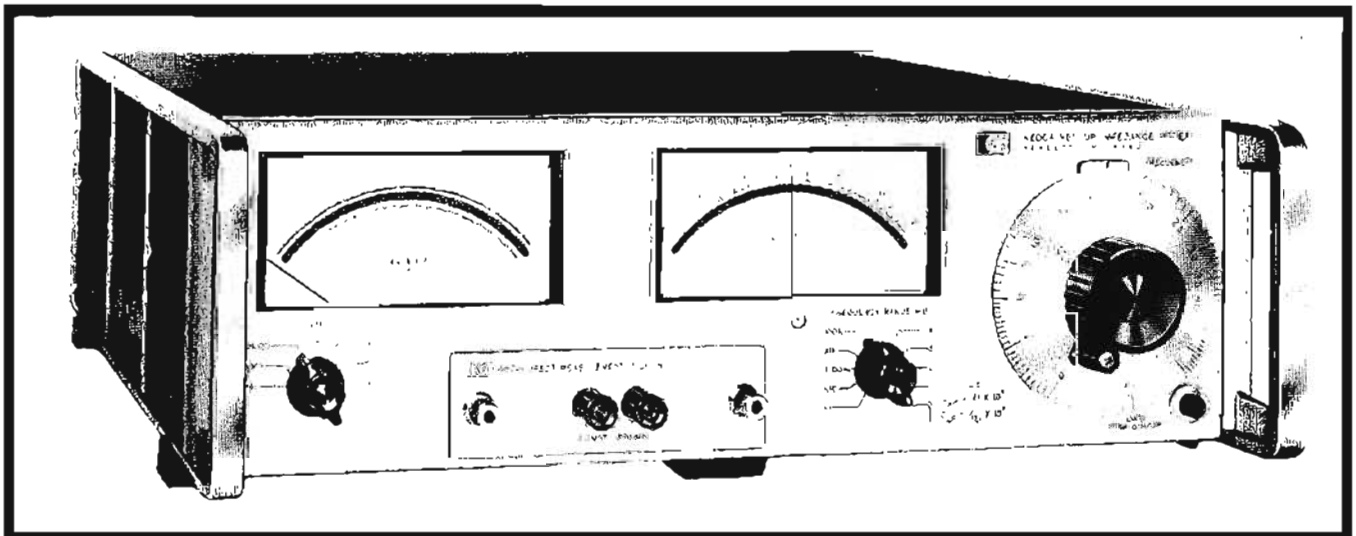

# RF VECTOR IMPEDANCE METER

Quickly, easily measure Z &  $\theta$ , .5 to 108 MHz  
Model 4815A



## IMPEDANCE

### Advantages:

- Direct reading of impedance and phase
- Convenient probe for in-circuit measurements
- Self calibration check provides measurement confidence
- Analog outputs for data recording
- Low-level test signal minimizes circuit disturbance

The HP 4815A RF Vector Impedance Meter provides all of the convenience of "probe and read" measurements. In use, the probe is connected directly into the circuit to be evaluated, frequency is selected, and complex impedance is read. This type measurement allows a straightforward adaptation to various jigs and fixtures for special measurements. Where only component values are to be determined, a quick-mount adapter is provided to allow rapid measurements. For critical component applications, the unit to be evaluated may be mounted directly in its working circuit and its value determined in its actual environment, at the frequency of interest.

### Specifications

#### Frequency

**Range:** 500 kHz to 108 MHz in five bands: 500 kHz to 1.5 MHz, 1.5 to 4.5 MHz, 4.5 to 14 MHz, 14 to 35 MHz, 35 to 108 MHz.

**Accuracy:**  $\pm 2\%$  of reading,  $\pm 1\%$  of reading at 1.592 and 15.92 MHz.

**RF monitor output:** 150 mV minimum into 50 ohms.

#### Impedance magnitude measurement

**Range:** 1 ohm to 100 k ohms; full-scale ranges: 10, 30, 100, 300, 1 k, 3 k, 10 k, 30 k, 100 k ohms.

**Accuracy:**  $\pm 4\%$  of full scale  $\pm \left( \frac{f}{30 \text{ MHz}} + \frac{Z}{25 \text{ k ohms}} \right) \%$

of reading, where  $f$  = frequency in MHz and  $Z$  is in ohms; reading includes probe residual impedance.

**Calibration:** linear meter scale with increments 2% of full scale.

#### Phase angle measurement

**Range:** 0 to 360° in two ranges:  $0 \pm 90^\circ$ ,  $180^\circ \pm 90^\circ$ .

**Accuracy:**  $\pm \left( 3 + \frac{f}{30 \text{ MHz}} + \frac{Z}{50 \text{ k ohms}} \right)$  degrees; where  $f$  = frequency in MHz and  $Z$  is in ohms.

**Calibration:** increments of 2°.

**Adjustments:** front panel screwdriver adjustments for Magnitude and Phase Zero.

#### Recorder outputs

**Frequency:** 0 to 1 volt from 0 to 1 k ohm source, proportional to dial rotation.

**Impedance magnitude:** 0 to 1 volt from 1 k ohm source.

**Phase angle:**  $0 \pm 0.9$  volt from 1 k ohm source.

**Dimensions:** 16 $\frac{3}{4}$ " wide, 7 $\frac{1}{4}$ " high, 18 $\frac{3}{4}$ " deep (426 x 185 x 476 mm).

**Weight:** net 39 lbs (17,6 kg), shipping 50 lbs (22,5 kg).

**Power:** 105 to 125 V or 210 to 250 V, 50 to 400 Hz, 50 W.

#### Accessories furnished:

1. 00600A Probe Kit: contains BNC Type "N" adapter, Probe Socket, 00601A Component Mounting Adapter, 2 probe center pins, probe ground assembly.
2. Rack Mount Kit.

**Price:** HP 4815A, \$2650.

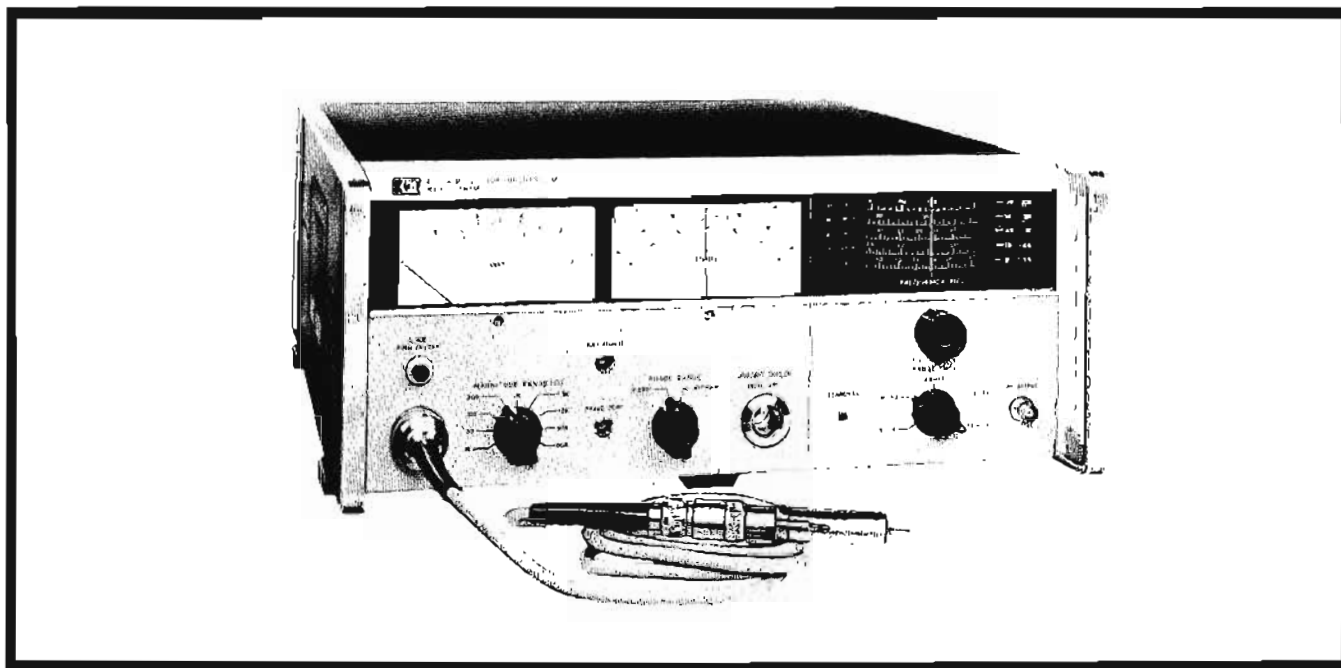

**IMPEDANCE****NETWORK ANALYZER**

Measure all network parameters, 0.11 to 12.4 GHz  
Model 8410A

**8410A Network Analyzer**

- ATTENUATION • PHASE • GAIN • IMPEDANCE • ADMITTANCE • REFLECTION COEFFICIENT AND ANGLE  
110 MHz to 12.4 GHz With One Simple System!

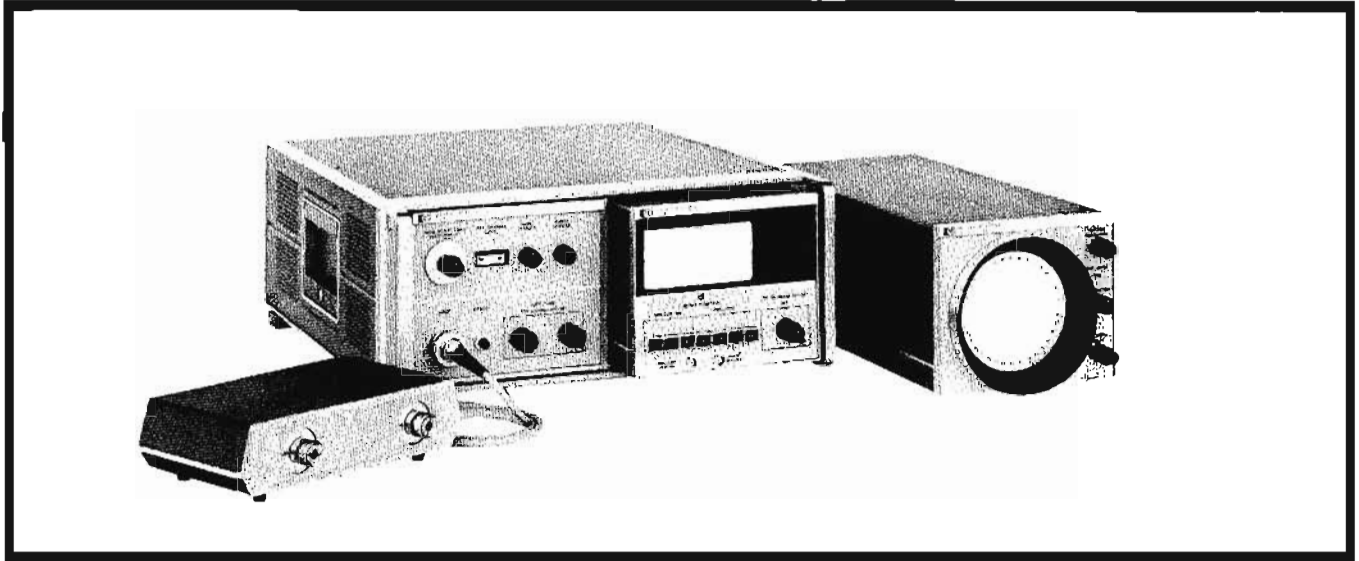

This one compact, low cost system measures all network parameters from 110 MHz to 12.4 GHz.

**Complete description of microwave devices**

Phase and amplitude data gives complete description of microwave devices. A powerful tool for component and systems design and test without ambiguity.

**Direct readout with choice of display**

Plug-in meter indicates magnitude and phase at spot frequencies. Wideband auxiliary outputs for swept displays on oscilloscope or X-Y recorder.

Plug-in CRT display for swept polar and Smith Chart readout. Auxiliary outputs for higher resolution X-Y plots.

Add display versatility with future plug-ins.

**Fast sweeps over octave bands**

Swept displays for fast testing over full band. Rapid sweep for dynamic CRT display — make adjustments to devices while viewing overall effects.

**Wide dynamic range — high resolution**

60 dB amplitude and 360° phase displays. Use precise offset controls to read amplitude and phase to 0.1 dB and 0.1 degree resolution. No phase ambiguity — meter indicates phase sense directly.

**Easy setup**

Transmission and reflection units complete the system; all RF hardware is connected and pre-calibrated inside three convenient modules. They provide:

- a calibrated variable measurement plane (line stretcher) to determine electrical and physical length of unknown devices in transmission tests. To eliminate graphical Smith Chart transformations in reflection tests.
- Rigid coaxial air line for stable RF connections. Adjustable RF line length for easy connection to unknown without flexible cables.

—Specified overall system accuracy for easier error analysis.

**Accurate**

Precision components assure basic system accuracy. Even greater accuracy possible at spot frequencies because vector errors, such as reflectometer directivity, can easily be calibrated out. This is a direct benefit to measuring *both* phase and amplitude.

**Basic system**

The 8410A main frame and 8411A Harmonic Frequency Converter provide basic RF tuning and IF conversion functions. Reference and test channel signals between 0.11 and 12.4 are converted to 20 MHz IF signals by the 8411A. Phase and amplitude relationship between input RF signals is maintained in the 20 MHz IF signals. The two IF signals are then fed through a 5 foot cable to the 8410A main frame. The flexible cable gives more freedom when making RF connection to large test devices. The 8410A main frame includes the automatic frequency tuning circuit, IF amplifiers, precision IF gain control and power supply for the 8411A and plug-in modules. A front panel switch selects the octave range desired between 0.1 and 12.4 GHz and the rest is automatic. The system phase locks to the frequency and follows it even during rapid sweep operation.

Model 8413A Phase-Gain Indicator plugs into the main frame to provide meter readout of relative amplitude and phase shift between the two signals. The meter is calibrated in  $\pm 3, 10, 30$  dB amplitude and  $\pm 6, 18, 60,$  and 180 degrees phase. Meter function and range are selected by convenient pushbutton switches. A phase offset switch, calibrated in precise 10 degree steps, allows any angle to be displayed on the  $\pm 6$  degree phase scale for 0.1° resolution. Separate dc outputs

can be used to display swept frequency plots of amplitude over 60 dB and up to 360° phase on an auxiliary oscilloscope or X-Y recorder (pp.103, 426).

Model 8414A Polar Display is an alternate plug-in for the 8410A main frame and provides a cathode ray tube readout. Magnitude and phase are displayed in polar coordinate form on a 5 inch internal graticule CRT.

Calibration of the CRT is in five linear amplitude steps (circular lines) and every 10 degrees phase (radial lines) over 360°. CRT overlays are provided for Smith Chart and expanded Smith Chart readout of normalized impedance or admittance. Conveniences include a beam center button to locate and center the trace, variable background illumination for CRT photos without ultraviolet light source in the camera, and X-Y outputs for high resolution polar plots. Two frequency marker signals may be fed into the 8414A from either the HP 8690A or 690C/D Series Sweep Oscillators. The markers show up as bright spots on the CRT display giving accurate frequency reference points.

Amplitude sensitivity is controlled by the 8410A in precise 10 and 1 dB steps along with a continuous vernier. Using this precise gain control, one can set up a unity  $\rho$  Smith Chart, calibrating with a short, then expand for full scale readings of say 0.2. Also, one can compress the scale for reading negative real impedances with a full scale of 3.16. CRT overlays are included for these three scales.

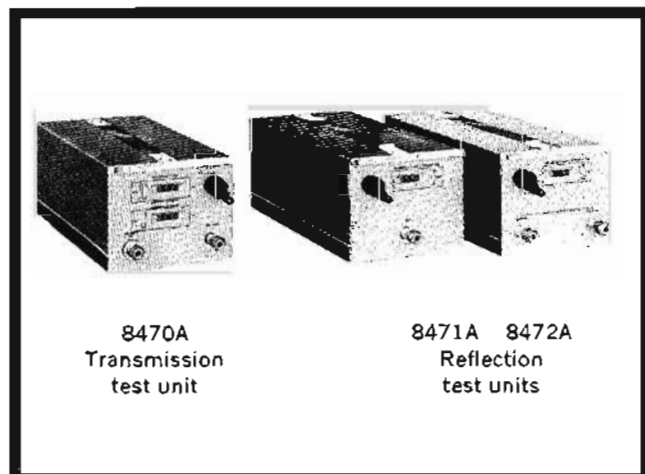

8470A  
Transmission  
test unit

8471A 8472A  
Reflection  
test units

### Transmission test unit

Model 8740A Transmission Test Unit provides convenient RF input and signal splitting functions for gain, phase, or attenuation tests with the 8410A. The unit operates over the full 0.11 to 12.4 GHz frequency range of the 8410A thus eliminating RF "hardware" changes when testing broadband coaxial components over several octaves.

RF input power is split into reference and test channel outputs for connection to the unknown and Model 8411A Converter. When a device is inserted between the 8740A and 8411A test channel connectors, a mechanical extension is required in the reference channel equal to the physical length of the test device. This extension is provided up to 10 cm by an adjustable air line in the 8740A. The line's extension is calibrated by a digital indicator.

A calibrated 30 cm line stretcher in the *test* channel can be used to effectively "stretch" the reference channel signal path. This allows compensation for linear delay in the test device and measurement of its electrical length compared to air line.

Fixed 10 and 20 cm lengths of air line with 7 mm connectors are available for testing devices longer than 10 cm. These fixed lines provide a great deal more system flexibility and are highly recommended accessories, especially when coax adapters are used. One 10 cm and one 20 cm line provide convenient combinations for testing devices up to 40 cm long.

### Reflection test units

Model 8741A Reflection Test Unit simplifies RF connections for impedance testing 0.11 to 2.0 GHz. The unit provides a complete phase-balanced reflectometer for swept or fixed frequency impedance tests with the 8410A. The unit includes a wideband dual directional coupler and line stretcher calibrated in centimeters by a digital indicator. Connection to the unknown device is made at a front panel 7 mm precision coax connector. (Adapters available for other types of connectors.) Incident and reflected voltages in the reflectometer are fed out to the Model 8411A Converter. Amplitude ratio and phase is measured by the 8410A/8413A as return loss in dB and angle, as complex impedance (or admittance) or as reflection coefficient and angle using the Model 8414A Polar Display.

A reference short is supplied for system calibration. The line stretcher is adjusted for equal phase shift between the incident and reflected signal paths in the reflectometer. This assures phase accuracy whenever test frequency is swept, or changed during spot frequency tests. The line stretcher can also be used to shift the reference plane. This makes possible direct impedance readings at any plane which would otherwise require graphical Smith Chart transformation.

Model 8742A Reflection Test Unit is a complete ultra-wide band reflectometer for impedance tests 2.0 to 12.4 GHz with the 8410A. A calibrated line stretcher performs the same functions described earlier for the lower range Model 8741A. The unit is the same as the 8741A in function and differs only slightly in outward appearance. Incident and reflected signals from the reflectometer are fed out the front panel. Connection to the unknown device is made on a side panel connector. All RF connections in the measure and reference channels are 7 mm precision coax for highest accuracy and repeatability. A reference short is provided for initial reflectometer calibration.

### Specifications

#### 8410 A Network analyzer (operating with 8411A)

**Instrument type:** measures relative amplitude and phase of two RF input signals; choice of two plug-in display modules for meter readout (8413A), or CRT polar display (8414A).

**Frequency range:** 0.11 to 12.4 GHz.

**Tuning:** automatic over octave band selected by front panel switch.

**Swept operation:** sweeps in octave bands; apply sweep reference voltage for fast sweep operation (compatible with sweep reference out of Model 8690A Sweep Oscillators\*).

**Input impedance:** 50 $\Omega$ , SWR <1.4 to 8 GHz, <2.0 to 12.4 GHz; connectors precision 7 mm coax (APC-7).

**Channel isolation:** >75 dB, 0.1 to 8.0 GHz; >60 dB, to 12.4 GHz.

#### Amplitude

##### Range:

**Reference channel:** -20 to -40 dBm ( $\cong$  22 to 2.2 mV); meter indicates proper range.

**Test channel:** -10 to 80 dBm ( $\cong$  71 mV to 22  $\mu$ V); not to exceed reference channel power by more than 10 dB.

**Maximum RF input to either channel:** 50 mW (damage level!).

**Maximum DC on RF line:**  $\pm$ 3 V.

**Amplitude control:** adjusts gain of test channel relative to reference channel.

**Range:** 69 dB total in 10 and 1 dB steps; vernier provides continuous adjustment over at least 2 dB.

**Accuracy:**  $\pm$ .05 dB per 10 dB step, not to exceed  $\pm$ 0.1 dB cumulative.  $\pm$ 0.01 dB per 1 dB step, not to exceed  $\pm$ .05 dB cumulative.

\*Simple resistive network required for 690C/D-Series Sweep Oscillators.



Table 1. System Components

Model	Function	Range	Price
8410A Network Analyzer	Mainframe for readout modules, includes tuning circuits, IF amplifiers, and precision IF attenuator.	0.11 to 12.4 GHz when used with Model 8411A	\$1,600
8411A Harmonic Frequency Converter	Converts 2 RF input signals 0.11 to 12.4 GHz into 20-MHz IF signals.	0.11 to 12.4 GHz when used with the 8410A. Impedance 50 ohms.	\$2,000
8413A Phase-Gain Indicator	Plug-in module for 8410A Mainframe provides meter display of relative amplitude and phase between input signals, auxiliary outputs for scope or X-Y <sub>1</sub> Y <sub>2</sub> , readout of phase-gain/attenuation.	Full scale = 3, 10, 30 dB and = 6, 18, 60, 180 degrees. Auxiliary outputs 50 mV/dB and 10 mV/degree.	\$775
8414A Polar Display	Plug-in module for 8410A Mainframe. CRT polar display of amplitude and phase. X-Y outputs for high resolution polar and Smith Chart impedance plots.	Internal graticule CRT for non-parallax viewing. Amplitude calibration in five linear steps. Phase in 10° intervals through 360° Smith Chart overlays for direct impedance readout (normalized to 50 ohms).	\$750

Model	Function	Range	Price
8740A Transmission Test Unit	Simplifies RF input and test device connection for attenuation or gain test. Accepts RF input signal from source and splits into reference and test channels for connection to 8411A and the unknown device. Calibrated line stretcher balances out linear phase shift when test device is inserted.	0.11 to 12.4 GHz. Impedance 50 ohms	\$1,000
8741A Reflection Test Unit	Wide-band reflectometer, phase balanced for swept or spot frequency impedance tests below 2 GHz. Accepts RF input and provides connections for unknown test device and 8411A. Movable reference plane	0.11 to 2.0 GHz	Available on request
8742A Reflection Test Unit	Ultra-wide band reflectometer, phase balanced for impedance tests above 2.0 GHz. Movable reference plane.	2.0 to 12.4 GHz	Available on request.

**Frequency response:** reference and test channels track within  $\pm 0.3$  dB to 8.0 GHz,  $\pm 0.5$  dB to 12.4 GHz.

**Noise:** less than  $-80$  dBm equivalent input noise (measured on 8413A Meter).

**Drift:**  $< \pm 0.05$  dB per degree C.

### Phase

**Range:** 0 to 360°.

**Control:** vernier provides continuous phase reference adjustment over at least 90°.

**Frequency response:** reference and test channels track within  $\pm 3^\circ$  to 8.0 GHz,  $\pm 5^\circ$  to 12.4 GHz.

**Drift:**  $< \pm 0.1^\circ$  phase per degree C.

### General

**Outputs:** two rear panel auxiliary outputs provide 278 kHz IF signals; outputs may be used for signal analysis, special applications, and convenient test points; modulation bandwidth nominally 10 kHz.

**Reference channel IF:** 2 volts peak-to-peak.

**Test channel IF:** 10 volts peak-to-peak or less, depending on signal level and test channel gain setting.

**Sweep reference input:** accepts dc voltage proportional to frequency for optimum swept-frequency operation; compatible with 0 to 40 volt per octave (nominal) sweep reference output of 8690-Series Sweep Oscillators.

**Power:** 115 or 230 volts  $\pm 10\%$ , 50 to 400 Hz, 70 watts (includes 8411A).

**Weight:** 8410A, 32 lbs; 8411A, 6¼ lbs.

**Dimensions:** 8410A 7½" high, 8⅜" deep, 16¼" wide; 8411A 2⅝" high, 5⅝" deep, 9" wide exclusive of connectors; 5' cable permanently attached for connection to 8410A.

**Price:** 8410A, \$1600; 8411A, \$2000.

### 8413A Phase-Gain Indicator (installed in 8410A)

**Instrument type:** plug-in meter display unit for 8410A. Displays relative amplitude in dB between reference and test channel inputs or relative phase in degrees. Pushbutton selection of meter function and range.

### Amplitude

**Range:**  $\pm 30$ , 10 and 3 dB full scale.

**Accuracy:**  $\pm 3\%$  of end scale.

**Log output:** 50 millivolts per dB up to 60 dB total; bandwidth 10 kHz nominal depending on signal level; source impedance 1 k $\Omega$ ; accuracy, same as meter.

**Linear output (rear panel):** 0 to 1 V maximum; 10 kHz bandwidth; 200 $\Omega$  source impedance.

**Drift:**

Log;  $< \pm 0.05$  dB per degree C.

Linear;  $< \pm 5$  mV per degree C.

### Phase

**Range:**  $\pm 180$ , 60, 18, 6 degrees full scale.

**Accuracy:**  $\pm 2\%$  of end scale.

**Output:** 10 millivolts per degree; 10 kHz bandwidth; 1 k $\Omega$  source impedance. Accuracy, same as meter.

**Drift:**  $< \pm 0.1$  degree per degree C.

**Phase offset:**  $\pm 180$  degrees in 10 degree steps.

**Accuracy:**  $\pm 0.3$  degrees per 10 degree step, not to exceed  $\pm 1.5$  degrees cumulative.

**Phase response versus signal amplitude:** 4 degrees maximum phase change for 60 dB amplitude change in test channel.

### General

**Power:** additional 15 watts supplied by 8410A.

**Weight:** 11 lbs.

**Dimensions:** 6" high, 15-9/16" deep, 7-9/32" wide (excludes front panel knobs).

**Price:** \$775.

#### 8414A Polar Display

**Instrument type:** plug-in CRT display unit for 8410A. Displays amplitude and phase data in polar coordinates on 5" cathode ray tube.

**Range:** normalized polar coordinate display; magnitude calibration 20% of full scale per division. Scale factor is a function of GAIN setting on 8410A. Maximum scale factor 3.16 (for 0 dB setting) decreasing to at least .0316 (for +40 dB setting); phase calibrated in 10 degree increments over 360 degree range.

**Accuracy:** error circle on CRT <3 mm radius.

**Outputs:** two dc outputs provide horizontal and vertical components of polar quantity. Maximum output  $\pm 10$  volts, <100 $\Omega$  source impedance, bandwidth (3 dB) 10 kHz.

**Drift:** CRT,  $\leq \pm 0.2$  mm/degree C; auxiliary outputs,  $\leq \pm 10$  mV/degree C.

**Beam center:** pressing BEAM CENTER simulates zero-signal input. Allows convenient beam position adjustment for reference.

### General

**CRT:** 5 inch, 5 kV post accelerator tube with P-2 phosphor; internal polar graticule.

**Marker input (rear panel):** accepts frequency marker output pulse from HP 8690-Series and 690-Series Sweep Oscillators, -5 volts peak. Markers displayed as intensified dot on CRT display.

**Blanking input (rear panel):** accepts -4 volt RF blanking pulse from HP 8690-Series and 690-Series Sweep Oscillators to blank retrace during swept operation.

**Background illumination:** controls intensity of CRT background illumination for photography. Eliminates need for ultraviolet light source in oscilloscope camera when photographing internal graticule.

**Power:** additional 35 watts supplied by 8410A.

**Weight:** 13 lbs.

**Dimensions:** 6" high, 15-9/16" deep, 7-9/32" wide (excludes front panel knobs).

**Price:** \$750.

#### 8740A Transmission Test Unit

**Instrument type:** RF power splitter and calibrated line stretcher for convenient transmission tests with 8410A. Provides reference and test channel RF outputs for connection to unknown device and the 8411A Converter.

**Frequency range:** dc to 12.4 GHz.

**Frequency response:** reference and test channel outputs track within  $\pm 0.5$  dB amplitude and  $\pm 3$  degrees phase.

**Output impedance:** 50 ohms, reflection coefficient 0.07 (1.15 SWR, 23 dB return loss) dc to 8 GHz; 0.11 (1.25 SWR, 19 dB return loss) 8.0 to 12.4 GHz.

**Maximum RF input power:** 1 watt.

**Connectors:** input, compatible Type N female stainless steel; output, APC-7.

**Reference plane extension:**

Electrical; 0 to 30 centimeters.

Mechanical; 0 to 10 centimeters.

Both extensions calibrated by digital indicators.

Indicators are adjustable for initial calibration.

**Power:** passive, no primary power required.

**Weight:** 17½ lbs.

**Dimensions:** 6" high, 16-3/16" deep, 7-9/32" wide (excluding knobs and connectors).

**Price:** \$1000.

#### 8741A and 8742A Reflection Test Units

**Instrument type:** wideband reflectometer, phase-balanced for swept or spot frequency impedance tests with 8410A. Calibrated variable reference plane.

**Frequency range:** 0.11 to 2.0 GHz (8741A); 2.0 to 12.4 GHz (8742A).

**Frequency response:** incident and reflected outputs from reflectometer track within  $\pm 0.5$  dB amplitude,  $\pm 3$  degrees phase ( $\pm 5$  degrees in 8742A).

**Impedance:** 50 ohms.

**Maximum RF input:** 30 watts.

**Residual reflection coefficient:** <0.01, 0.1 to 1.0 GHz; <0.02, 1.0 to 2.0 GHz (8741A); <0.03, 2.0 to 12.4 GHz (8742A).

**Connectors:** input, Type N female, stainless steel; incident, reflected, and unknown reflectometer ports APC-7.

**Reference plane extension:** 0 to 15 cm (8741A); 0 to 17 cm (8742A); calibrated by digital dial indicator. Indicator is adjustable for initial calibration.

**Power:** passive, no primary power required.

**Weight:** 16½ lbs (8741A); 15½ lbs (8742A).

**Dimensions:** 6" high, 16-3/16" deep, 7-9/32" wide (not including connectors and knobs).

**Prices:** on request.

#### Accessories furnished

**Smith Chart CRT overlays:** plastic overlays for 8414A Polar Display converts readout to normalized impedance or admittance. Full scale = 3.16 (for negative real impedances); 1.0 and 0.2; (furnished with 8414A).

**Coaxial short:** for calibrating 8741A, 8742A Reflectometers; APC-7 connector; (furnished with 8741A and 8742A).

#### Accessories available

**Coaxial adapters:** 11524A, APC-7 to N female; 11525A, APC-7 to N male. Other adapters available from Amphenol RF Division, Danbury, Connecticut.

**Fixed air line extensions:** 11566A, 10 cm overall length; 11567A, 20 cm overall length. APC-7 connectors at both ends. (Prices available on request.)

**Coaxial terminations:** 909A fixed, 50 $\Omega$ ; 907A sliding 50 $\Omega$ , APC-7 or Type N connectors.

**Coaxial short:** calibrates 8741A, 8742A Reflectometers when adapted to Type N connectors. 11511A Type N female; 11512A type N male.

**Fixed coaxial attenuators:**

8492A, dc to 18 GHz, APC-7 connectors.

Nominal attenuation; Option 03, 3 dB; Option 06, 6 dB; Option 10, 10 dB; Option 20, 20 dB. Maximum input power 2 watts.

8491A, dc to 12.4 GHz; 8491B, dc to 18 GHz, Type N connectors.

Nominal attenuation; Option 03, 3 dB; Option 06, 6 dB; Option 10, 10 dB; Option 20, 20 dB. Maximum input power 2 watts.

#### Complementary equipment

**Sweep oscillators:** HP 8690A and plug-in RF units covering 8410A range and beyond.

**Oscilloscopes:** HP 140A and 1405A Dual Trace and 1420A Horizontal plug-ins.

**X-Y Recorders:** Moseley 136A two pen recorder, 8½" x 11"; 2FA two pen recorder, 11" x 17".



Analysis of capacitors, inductors, and resistors for low-frequency applications is commonly made with a universal bridge. Universal bridges have considerable versatility, being able to measure not only resistance, capacitance, and inductance over wide ranges, but also the Q of inductances and the dissipation

factor ( $\frac{1}{Q}$ ) of capacitors. This versatility,

however, has led in the past to complicated control panels, oftentimes making it not so simple for the occasional user to make bridge measurements, without recourse to study of the instructional manual. A new universal bridge (HP Model 4260A, page 250) has been designed, which removes the confusing elements which have previously been associated with bridge operation. The readout is direct. Measurement results are displayed by an in-line digital readout, and the decimal point is placed automatically by the range switch. The unit of measurement (e.g.,  $\mu\text{F}$ ), as selected by the function and range switches, is shown in the window. Multiplication factors need not be applied to the reading. The only terminals on the front panel are those for the unknown component. See Figure 1.

The bridge measures resistance values

from 10 milliohms to 10 megohms, inductances from 1 microhenry to 1000 henry, and capacitances from 1 pF to 1000  $\mu\text{F}$ . Measurement accuracy is, at worst,  $\pm 2\%$ , and is better than  $\pm 1\%$  through the major portion of the range.

Q is measured, in the series configuration, from 0.02 to 20; Q of R in parallel with L is measurable in a range from 8 to 1000. The dissipation factor (D) of capacitors is measured from 0.001 to 0.12 for series C and R, and from 0.05 to 50.0 with parallel C and R. The accuracy of D and Q measurements is  $\pm 5\%$ , or better.

Inside the bridge is a driving oscillator, operating at 1 kHz. Other frequencies within a range of 20 Hz to 20 kHz may be used to drive the bridge, rear panel terminals being provided for the connection of external oscillators and detectors.

A generalized ac impedance bridge is shown in Fig. 2. The bridge is driven by an ac source across the corners OQ. When the voltage across arm OP equals the voltage across arm OS, the output voltage, expressed across the detector connected to P and S, is zero. The bridge is balanced, or nulled; the product of the impedance across OS and that across PQ is equal to the product of the impedance across SQ and that across OP. Now the value of any of the four im-

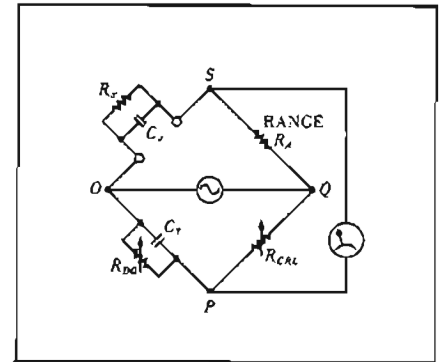

Figure 2. Generalized ac bridge configuration. OQ is bridge driving voltage. OS is fixed by value of unknown component and setting of RANGE switch. OP is determined by  $R_{CN}$  and  $R_{DP}$  controls and  $C_T$ . When balanced, voltage across PS is zero.

pedances can be calculated if the other three are known.

An internal dc supply is used for measurements of resistance and an internal 1-kHz oscillator drives the bridge for measurements on capacitors and inductors. In ac bridge measurements of reactive components, not only must the ac signal amplitude at the known and unknown bridge corners be equal, but the signals must also be in phase if a null is to be achieved. It has been usual in



Figure 1. New Universal Bridge has digital read-out, automatic decimal placement, non-ambiguous range indication, and other features that simplify measurement of resistance, capacitance, inductance, Q, and loss factor. Bridge design eliminates prolonged balancing procedures formerly caused by sliding null in measurements of lossy relative components. Control circuitry automatically brings DQ resistor to correct value as CRL dial is adjusted for a null.



# C, R, L, D, & Q MEASUREMENTS



# IMPEDANCE

the past to require that two controls ( $R_{CRL}$  and  $R_{DQ}$ ) be operated, to bring the bridge into balance. These controls interacted, particularly when lossy re-activated components were measured, and it was necessary to adjust each alternately, several times, to bring the detector to minimum (or null).

Null procedure in Hewlett-Packard's new Model 4260A Universal Bridge is greatly simplified by using a feedback control system to make one of the bridge adjustments automatically. To find the value of an unknown C or L, the bridge is switched into its AUTO mode, and then it is necessary only to adjust one control (CRL) for balance. The other is automatically brought to the correct value. Now C or L can be read directly, after balancing the bridge with one adjustment of the CRL control.

The dissipation factor for capacitors (D) or quality factor for inductors (Q) is found by switching a manually-controlled resistance, after the initial balance with the CRL control has been reached. A DQ control *then* is adjusted for second null indication. The bridge thus may be brought to complete balance with only two adjustments; there is no "chasing" of the null through further alternate adjustments of any interacting controls.

## Q meters

The Q of a resonant circuit, comprising a variable known capacitor ( $C_n$ ) contained in the Q meter and an external inductor ( $L_x$ ), is measured by impress-

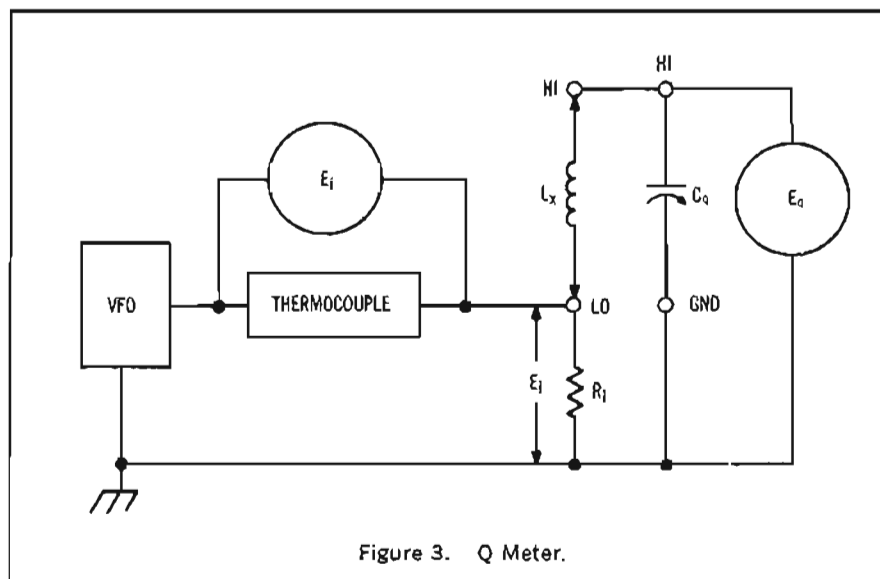

Figure 3. Q Meter.

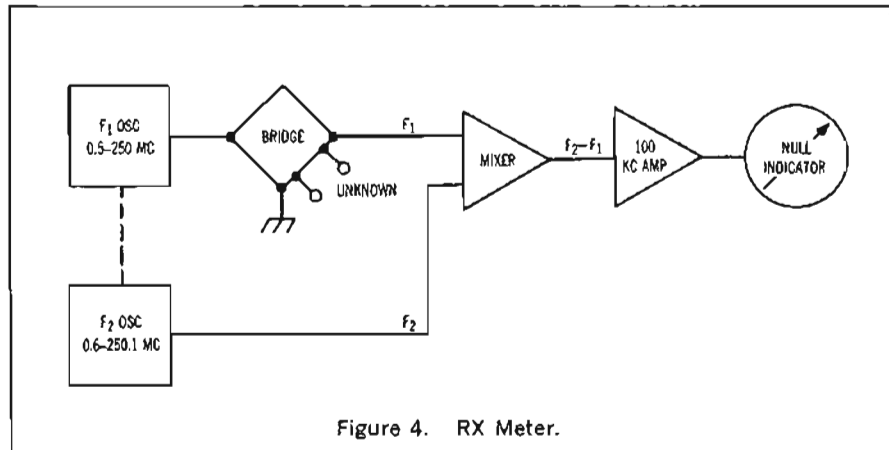

Figure 4. RX Meter.

ing a signal of known voltage ( $E_i$ ) and variable known frequency in series in the circuit, and measuring the voltage ( $E_n$ ) across the capacitor when the circuit is resonated to the chosen frequency of the impressed voltage. Q of the circuit is the ratio  $E_n/E_i$ . With  $E_i$  known, the voltmeter measuring  $E_n$  can be calibrated directly in Q. By inserting low impedances in series with the inductor  $L_x$ , or high impedances in parallel with the capacitor  $C_n$ , the constants of unknown circuits or components may be measured in terms of their effect on the original circuit Q and tuning capacitance.

To calibrate these meters, Hewlett-Packard provides Q standards which are standard inductors of calibrated Q. A series of convenient reference inductors is also available from HP for use as known constants or substitutes in the  $L_x$  position.

There are two Q meters in the HP family. Model 260A is for the frequency range 50 kHz to 50 MHz which may be extended down to 1 kHz by using a suitable external oscillator with a Model 00564A Coupling Unit. Model 190A serves the range 20 MHz to 260 MHz.

## RX meter

The HP Model 250A RX Meter directly presents the parallel resistive and reactive constituents of Z, for two-terminal networks, in the range from 0.5 to 250 MHz.

The output of the 0.5 to 250 MHz test oscillator ( $F_1$ ) is fed into a Schering bridge. When the impedance to be measured is connected across one arm of the bridge, the equivalent parallel resistance and reactance unbalance the bridge, and the resulting voltage is fed to the mixer. The output of the 0.6 to 250.1 MHz oscillator ( $F_2$ ), tracking 100 kHz above  $F_1$ , also is fed to the mixer, resulting in a 100 kHz difference frequency proportional in level to the bridge unbalance. This is amplified selectively to provide desired balance sensitivity. When the bridge R and C controls are nulled, their respective dials accurately indicate the parallel impedance components of the test sample.

The instrument's range of measurement is 15 to 100,000 ohms for parallel resistance (0 to 15 ohms by indirect means), 0.1 to 100 pF (120 pF by indirect means) for C, and 0.001  $\mu$ H to 100 mH for L. Access to the measurement circuit through Type N coaxial connectors may be had by installing the Model 00515A Adapter Kit.



## UNIVERSAL BRIDGE

Simplified, easy to read impedance measurement  
Model 4260A

### Advantages:

- Electronic AUTOBALANCE — single control null
- Digital Readout for C, R, L
- Direction Indicators for fast range selection and balance

Measurements of C, R, L, D (dissipation factor of capacitors), and Q are easily made with the new Model 4260A Universal Impedance Bridge.

The readout for C, R and L is digital with the decimal point automatically positioned. Units of measurement and the equivalent circuit automatically appear with a twist of the function switch. There are no multipliers or confusing non-linear dials which need interpolation.

Operation is simple. Set the function knob for the parameter to be measured, adjust the range switch for an on-scale indication, and obtain a null with the CRL control. There are no interacting controls to adjust and readjust. There are no false nulls. A unique electronic AUTOBALANCE circuit solves all these problems. Components with low Q or high D are as easy to measure as those without loss.

For D or Q measurements, switch out of AUTO and turn the DQ control until another null is obtained. Only one adjustment is needed for each measurement.

Five bridge circuits are incorporated in the 4260A; each is composed of stable, high-quality components for good accuracy and linearity. An internal 1 kHz drives the bridge.

Nulling is easy. Illuminated pointers ( $\langle \text{CRL} \rangle$ ) automatically tell whether a null is up- or down-scale. Both range and CRL controls can be set watching these pointers.

Components may be biased by connecting a battery to the rear terminals. An external oscillator and detector can be used for measurements in the 20 Hz - 20 kHz range.

The compact modular cabinet is ideal for bench use; and it may be rack mounted using accessory hardware. A tilt stand is provided to raise the viewing angle; it also serves as a convenient carrying handle.

### Specifications

#### Capacitance measurement

##### Capacitance

**Range:** 1 pF to 1000  $\mu$ F, in 7 ranges.

##### Accuracy:

- $\pm (1\% + 1 \text{ Digit})$ , from 1 nF to 100  $\mu$ F.
- $\pm (2\% + 1 \text{ Digit})$ , from 1 pF to 1 nF and 100  $\mu$ F to 1000  $\mu$ F.

##### Dissipation factor

##### Range:

- LOW D—(of series C): 0.001 to 0.12.
- HIGH D—(of parallel C): 0.05 to 50.

##### Accuracy: for C > 100 pF.

- LOW D—(of series C):  $\pm (5\% + 0.002)$  or  $\pm \text{ONE DIAL DIVISION}$ , whichever is greater.
- HIGH D—1/D (of parallel C):  $\pm (5\% + 0.05)$  or  $\pm \text{ONE DIAL DIVISION}$  of LOW Q dial, whichever is greater.

#### Inductance measurement

##### Inductance

**Range:** 1  $\mu$ H to 1000 H, in 7 ranges.



##### Accuracy:

- $\pm (1\% + 1 \text{ Digit})$ , from 1 mH to 100 H.
- $\pm (2\% + 1 \text{ Digit})$ , from 1  $\mu$ H to 1 mH and 100 H to 1000 H.

##### Quality factor

##### Range:

- LOW Q—(of series L): 0.02 to 20.
- HIGH Q—(of parallel L): 8 to 1000.

#### Auto-balance

Eliminates need for DQ adjustments in parallel C and series L measurements at 1 kHz.

**Accuracy:** for D < 1 and Q > 1 add  $\pm 0.5\%$  to C and L accuracy specifications.

#### Resistance measurement

**Range:** 10 millivolts to 10 megohms, in 7 ranges.

##### Accuracy:

- $\pm (1\% + 1 \text{ Digit})$ , from 10 ohms to 1 megohm.
- $\pm (2\% + 1 \text{ Digit})$ , from 10 milliohms to 10 ohms and 1 megohm to 10 megohms.

#### Oscillator and detector

**Internal oscillator:** 1 kHz  $\pm 2\%$ , 100 mV rms  $\pm 20\%$ .

**Internal detector:** tuned amplifier at 1 kHz; functions as a broad-band amplifier for measurements with external oscillator.

#### General

**Power:** 115 or 230 volts  $\pm 10\%$ , 50-60 Hz, approx. 7 watts.

**Dimensions:** 7-25/32" wide, 6-17/32" high, 11" deep (190 x 166 x 279 mm).

**Weight:** net, 11 lbs (5 kg). Shipping, 15 lbs (6.8 kg).

##### Optional accessories:

HP 419A for accurate R measurements < 10 ohms and > 1 M ohms.

HP 204B for measurements 20 Hz - 20 kHz.

HP 140A/1400A or external tuned null detector with 90 dB gain and  $Z_{in} > 10 \text{ k ohms}$  for measurements 20 Hz - 20 kHz.

**Price:** Model 4260A Universal Bridge, \$550.00.

Manufactured by Yokogawa-Hewlett-Packard Ltd., Tokyo.

## RX METER

Self-contained rf bridge, 500 kHz to 250 MHz  
Model 250A



# IMPEDANCE

The HP 250A RX Meter is a completely self-contained instrument for use in measuring the equivalent parallel resistance and capacitance or inductance of two terminal networks. The instrument's design includes an accurate, continuously tuned oscillator, high-frequency bridge, amplifier-detector and null indicating meter.

The oscillator, which is carefully designed to minimize temperature effects, is mounted inside a rigid casting in order to obtain a high degree of accuracy, stability and low leakage. A long-life sub-miniature triode is used, and the unit is carefully shielded to avoid any leakage of signal to the amplifier-detector by any path other than through the bridge. The high-frequency bridge is also mounted inside a

casting and is specially designed to minimize the effects of coupling between arms.

### Quality variable components

All calibrated variable elements of the bridge are special low-inductance, high-quality variable capacitors driven by anti-backlash gears. Connections to the unknown impedance are arranged for almost zero lead length. Convenient, easily adjusted bridge balance controls are available.

The amplifier-detector null indicator has high, automatically controlled gain and a very low noise level. The power supply is internally regulated.

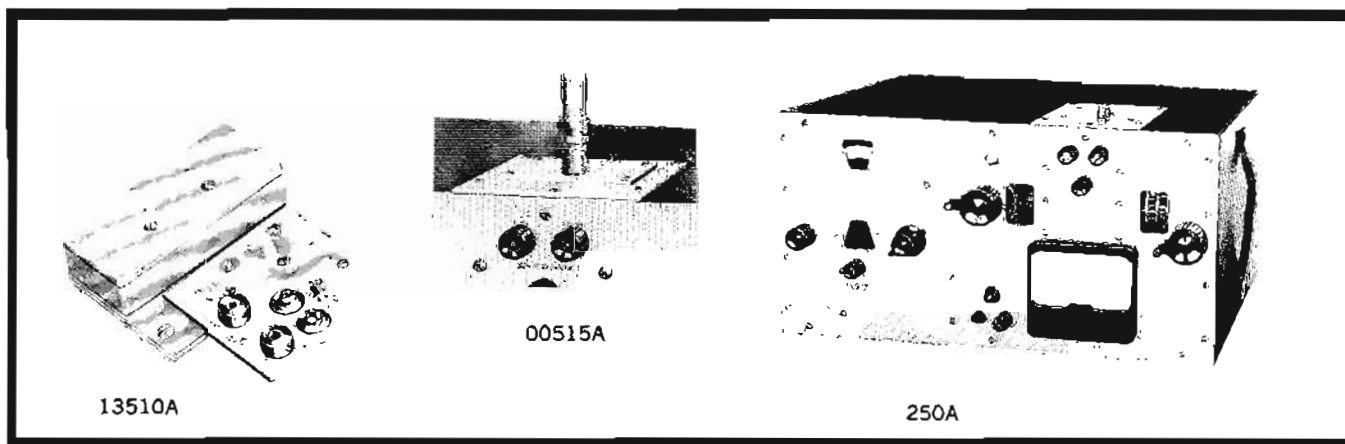

### Specifications

#### Radio frequency characteristics

**RF range:** total range: 500 kHz to 250 MHz; number bands: 8; band ranges: 0.5 to 1 MHz, 1 to 2 MHz, 2 to 4 MHz, 4 to 9 MHz, 9 to 21 MHz, 21 to 48 MHz, 48 to 110 MHz, 110 to 250 MHz.

**RF accuracy:**  $\pm 1\%$ .

**RF calibration:** increments of approximately 1%.

#### Resistance measurement characteristics

**Resistance range:** 15 to 100,000 ohms.

**Resistance accuracy:**  $\pm \left[ 2 + \frac{F}{200} + \frac{R}{5000} + \frac{Q}{20} \right] \%$

$\pm 0.2$  ohm;  $F$  = frequency (MHz),  $R$  = RX Meter  $R_p$  reading (ohm),  $Q = \omega CR \times 10^{-12}$ , where  $C$  = RX Meter  $C_p$  reading (pF).

**Resistance calibration:** increments of approximately 3% throughout most of range.

#### Capacitance measurement characteristics

**Capacitance range:** 0 to 20 pF (may be extended through use of auxiliary coils).

**Capacitance accuracy:**  $\pm (0.5 + 0.5 F^2 C \times 10^{-5}) \%$   
 $\pm 0.15$  pF;  $F$  = frequency (MHz),  $C$  = RX Meter  $C_p$  reading (pF).

**Capacitor calibration:** 0.1 pF increments.

#### Inductance measurement characteristics

**Inductance range:** 0.001  $\mu$ h to 100 mh (actual range depends upon frequency; auxiliary resistors employed).

**Inductance accuracy:** basic accuracy is capacitance accuracy given above.

#### Measurement voltage level

**RF:** 0.05 to 0.75 V approx., depending upon frequency (may be reduced to 20 mV by installation of auxiliary potentiometer).

**DC:** 0 V; (external dc current up to a 50 mA, may be passed through RX meter terminals).

**Accessories available:** 00515A Coax Adapter Kit (designed to permit connection to the RX meter bridge circuit of any coaxial transmission line or fixture fitted with a Type "N" male connector), \$49.50; 13510A Transistor Test Jig (provides a convenient means for measuring Y parameters  $Y_{11b}$ ,  $Y_{11e}$ , and  $Y_{22e}$  of transistors on the RX meter over the frequency range of 500 kHz to 250 MHz), \$195.

#### Physical characteristics

**Dimensions:** 20" wide, 10 $\frac{3}{8}$ " high, 13 $\frac{1}{2}$ " deep (508 x 264 x 343 mm).

**Weight:** net 40 lbs (18 kg); shipping 50 lbs (22.5 kg).

**Power:** 105 to 125 volts or 210 to 250 volts, 50 to 1000 Hz, 60 watts.

**Price:** HP 250A, \$1795.



## Q METER

Expanded scale for Q measurements  
Model 260A

The direct-reading expanded scale of the HP 260A Q Meter permits measurement of Q down to 10 and also permits reading of very small changes in Q resulting from the variation of the test parameter.

The Q meter was first designed and introduced as a means of measuring the Q or "figure of merit" of coils. Improved models and broadened applications have kept pace with new measuring needs, and today the Q meter is recognized as a flexible general-purpose device with a large number of uses.

### Circuit technique

The Q meter consists of a self-contained, continuously variable, stable oscillator, whose controlled and measured output is applied in series with a series-tuned, resonant circuit. A vacuum tube voltmeter with high input impedance is connected across the internal variable capacitor portion of the tuned circuit to measure the reactive voltage in terms of circuit Q. The coil portion of the tuned circuit is connected externally and represents the unknown to be measured. By inserting low impedances in series with the coil or high impedances in parallel with the capacitor, the parameters of unknown circuits or components can be measured in terms of their effect on the circuit Q and resonant frequency.

### Usefulness, special features of the 260A

The 260A is typical of these instruments. It is useful for direct reading of circuit Q on its parallax-free meter. From such measurements, the distributed capacity, effective inductance and self-resonant frequency can be determined. On capacitors, capacitance from 0.1 pF to 100  $\mu$ F and Q from 10 to 10,000 can be evaluated from measurements made with and without the component connected. Capacitor self-resonant frequency also can be determined.

Effective rf resistance, inductance or capacitance, and Q of resistors also may be determined, and, used on IF and rf transformers, the 260A will measure effective impedance, Q, coefficient of coupling, mutual inductance and frequency response. The Q meter also is useful for making measurements of dielectric constant and dissipation factor on insulating materials.

The HP 260A utilizes a rugged thermocouple operating at half rated power; oscillator output is factory-adjusted to avoid overload. Both these features guard against accidental thermocouple overload. Through the use of an internal regulating transformer and an electronically regulated power supply, the operation of the instrument is not affected by normal power line fluctuations.

Teflon insulation has been provided for 260A terminals, providing mechanical stability and low electrical loss. The oscillator output is controlled by varying the screen grid voltage of the oscillator tube to obtain smooth operation, as well as good waveshape. A 0.02-ohm annular insertion resistor is used to improve 260A accuracy. Provision is made for use of an external oscillator to supply the Q meter through a matching transformer (HP 00564A) to provide operation below 50 kHz down to 1000 Hz. A scale also is provided to read inductance directly at selected frequencies.

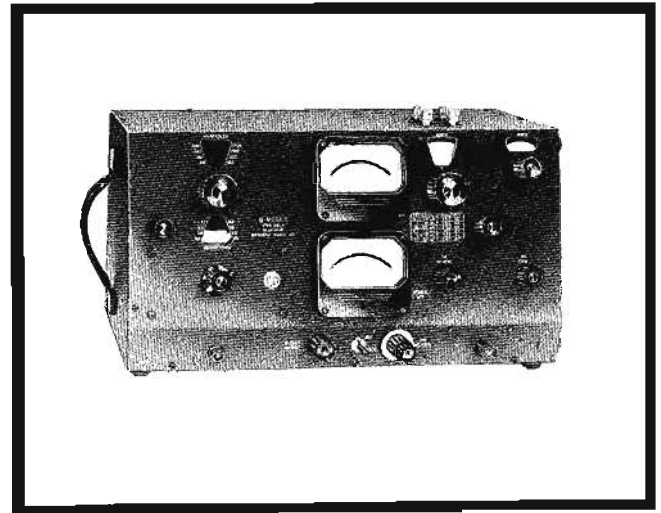

### Specifications

#### Radio frequency characteristics

**RF range:** total range: 50 kHz to 50 MHz, 1 kHz to 50 kHz (with external oscillator); number bands: 8; band ranges: 50 to 120 kHz, 120 to 300 kHz, 300 to 700 kHz, 700 to 1700 kHz, 1.7 to 4.2 MHz, 4.2 to 10 MHz, 10 to 23 MHz, 23 to 50 MHz.

**RF accuracy:**  $\pm 2\%$ .

**RF calibration:** increments of approximately 1%.

#### Q measurement characteristics

**Q range:** total range: 10 to 625; low range: 10 to 60;  $\Delta$  range: 0 to 50.

**Q accuracy:**  $\pm 5\%$ , 50 kHz to 30 MHz;  $\pm 10\%$ , 30 MHz to 50 MHz (for circuit Q of 250 read directly on indicating meter).

**Q calibration:** main scale: increments of 5 from 40 to 250; low scale: increments of 1 from 10 to 60;  $\Delta$  scale: increments of 1 from 0 to 50; XQ scale: increments of 0.1 from 1 to 1.5 and increments of 0.5 from 1.5 to 2.5.

#### Inductance measurement characteristics

**L range:** 0.09  $\mu$ H to 130 mH (effective inductance), direct reading at six specific frequencies.

**L accuracy:**  $\pm 3\%$  (for resonating capacitance  $> 100$  pF and inductance  $> 5$   $\mu$ H).

#### Resonating capacitor characteristics

**Capacitor range:** main: 30 to 460 pF; vernier:  $-3$  to  $+3$  pF.

**Capacitor accuracy:** main:  $\pm 1\%$  or 1 pF, whichever is greater; vernier:  $\pm 0.1$  pF.

**Capacitor calibration:** main: 1 pF increments 30 to 100 pF, 5 pF increments 100 to 460 pF; vernier: 0.1 pF increments.

#### Physical characteristics

**Mounting:** sloping front cabinet, for bench use.

**Finish:** gray wrinkle, engraved panel (other finishes available on special order).

**Dimensions:** 21  $\frac{1}{4}$ " wide, 11  $\frac{3}{4}$ " high, 10" deep (540 x 298 x 254 mm).

**Weight:** net 40 lbs (18 kg); shipping 55 lbs (24.8 kg).

**Power:** 260A: 95 to 130 volts, 60 Hz, 65 watts; 260AP: 95 to 130 volts, 50 Hz, 65 watts.

**Accessories available:** 00103A Inductors, 00513/00518A Q Standards, 00564A Coupling Unit.

**Price:** HP 260A, AP, \$990.

# Q METER ACCESSORIES

Q standards, inductors, coupling transformer  
Models 00513A, 00518A, 00103A, 00564A



## IMPEDANCE



00518A

00564A

00513A

00103A

### 00103A Inductors

The HP 00103A Inductors are designed specifically for use in the Q circuit of the 160A and 260A Q Meters, for measuring the rf characteristics of capacitors, insulating materials, resistors, etc. Price: HP 00103A, \$17.75 each; HP 00127A, set of 16 inductors for 260A, \$255; HP 00128A, set of 17 inductors for 160A, \$270.

### Specifications, 00103A

HP model	Inductance	Approx. resonant frequency for tuning capacitance of:			Approx. Q	Capacitance pF
		400 pF	100 pF	50 pF		
00103-A1	1 $\mu$ h	8	16	20 MHz	180	6
00103-A2	2.5 $\mu$ h	5	10	14 MHz	200	6
00103-A5	5 $\mu$ h	3.5	7	10 MHz	200	6
00103-A11	10 $\mu$ h	2.5	5	7 MHz	200	6
00103-A12	25 $\mu$ h	1.5	3	4.5 MHz	200	6
00103-A15	50 $\mu$ h	1.1	2.2	3 MHz	200	6
00103-A21	100 $\mu$ h	800	1600	2000 kHz	200	6
00103-A22	250 $\mu$ h	500	1000	1400 kHz	200	6
00103-A25	500 $\mu$ h	350	700	1000 kHz	170	7
00103-A31	1 mh	250	500	700 kHz	170	7
00103-A32	2.5 mh	150	300	450 kHz	170	8
00103-A35	5 mh	110	220	300 kHz	160	8
00103-A41	10 mh	80	160	200 kHz	140	9
00103-A42	25 mh	50	100	140 kHz	110	9
		100 pF		36 pF		
00103-A50	0.5 $\mu$ h	20 MHz		35 MHz	225	5.5
00103-A51	0.25 $\mu$ h	30 MHz		50 MHz	225	5.5
00103-A52	0.1 $\mu$ h	45 MHz		75 MHz	225	3.5

### 00513A Q Standards

HP 00513A Q Standards are shielded reference inductors which have accurately measured and highly stable inductance and Q characteristics. Specifically designed for use with the 160A and 260A Q Meters, the Q standards are particularly useful as a means for checking the overall operation and accuracy of these instruments, as well as for providing precisely known supplementary Q circuit inductance desirable for many impedance measurements by the parallel method. Price: HP 00513A, \$97 each.

Nominal values for HP 513A				
	L-250 $\mu$ h		Cd-8 pF	
	0.5 MHz	1 MHz	1.5 MHz	
Q <sub>s</sub>	190	250	220	
Q <sub>i</sub>	183	234	200	

Actual values of all these quantities are marked on the name plate of the Q standard; with the unit in the Q circuit, approximate resonant frequencies of 500, 1000 and 1500 kHz are obtained with tuning capacitances of 400, 100 and 50 pF, respectively.

### 00518A Q Standards

HP 00518A Q Standards, used in conjunction with the 00513A Q Standards, provide frequency coverage from 50 kHz to 50 MHz—the entire range of the 260A Q Meter. These units are useful as precision inductors and as a fast, convenient means for checking the overall operating accuracy of Q meters. Price: HP 00518A, \$97 each; HP 00538A, set of five 00518A and one 00513A, \$525.

### Specifications, 00518A

HP model	00518-A1	00518-A2	00518-A3	00518-A4	00518-A5
Inductance	0.25 $\mu$ h	2.5 $\mu$ h	25 $\mu$ h	2.5 mh	25 mh
Low freq. data:					
Frequency	15 MHz	5 MHz	1.5 MHz	150 kHz	50 kHz
Resonating C	420 pF	395 pF	440 pF	440 pF	400 pF
Indicated Q	175	195	175	170	90
Middle-freq. data:					
Frequency	30 MHz	10 MHz	3 MHz	300 kHz	100 kHz
Resonating C	100 pF	95 pF	105 pF	100 pF	85 pF
Indicated Q	235	235	225	180	130
High-freq. data:					
Frequency	45 MHz	15 MHz	4.5 MHz	450 kHz	150 kHz
Resonating C	40 pF	40 pF	45 pF	40 pF	35 pF
Indicated Q	225	205	230	135	125

(Table shows nominal values)

### 00564A Coupling Unit

The 00564A Coupling Transformer Unit is designed to couple the output of an external oscillator into the 160A or 260A Q Meter for the purpose of extending the operation range of the Q meter to the low-frequency region. By means of the coupling unit and an auxiliary oscillator, the Q meter may be operated down to a low-frequency limit of 1 kHz. The oscillator should supply a variable voltage of 22 volts maximum into an impedance of 500 ohms. Price: HP 00564A, \$39.75.



## Q METER, INDUCTORS

Direct Q measurements, 20 to 260 MHz  
Models 190A, 00590A

### 190A Q Meter

The HP 190A Q Meter finds applications similar to those described for the 260A Q Meter (page 252), but in the vhf range of frequencies. This instrument does not have a thermocouple, but employs a special coupling impedance to introduce voltage across the series-tuned, resonant circuit. This voltage, as well as the reactive voltage developed across the internal Q capacitor, is measured by two high-impedance, low input capacitance vacuum tube voltmeters and indicated on a single front-panel parallax-free meter.

### Specifications, 190A

#### Radio frequency characteristics

**RF range:** total range: 20 to 260 MHz; number bands: 4; band ranges: 20 to 40 MHz, 40 to 80 MHz, 80 to 160 MHz, 160 to 260 MHz.

**RF accuracy:**  $\pm 1\%$ .

**RF calibration:** increments of approximately 1%.

#### Q measurement characteristics

**Q range:** total range: 5 to 1200; low range: 10 to 100;  $\Delta$  range: 0 to 100.

**Q accuracy:**  $\pm 7\%$  20 to 100 MHz;  $\pm 15\%$  100 to 260 MHz (for circuit Q of 400 read directly on indicating meter).

**Q calibration:** main scale: increments of 10 from 50 to 400; low scale: increments of 2 from 10 to 100;  $\Delta$  scale: increments of 2 from 0 to 100; XQ scale: increments of 0.1 from 0.5 to 1.5, increments of 0.5 from 1.5 to 3.

#### Resonating capacitor characteristics

**Capacitor range:** 7.5 to 100 pF.

**Capacitor accuracy:**  $\pm 0.2$  pF, 7.5 to 20 pF;  $\pm 0.3$  pF, 20 to 50 pF;  $\pm 0.5$  pF, 50 to 100 pF.

**Capacitor calibration:** 0.1 pF increments.

**Accessories available:** 00590A Inductors.

#### Physical characteristics

**Dimensions:** 14 $\frac{1}{4}$ " wide, 10 $\frac{1}{8}$ " high, 10 $\frac{1}{2}$ " deep (362 x 257 x 267 mm).

**Weight:** net 25 lbs (11,3 kg); shipping 32 lbs (14,4 kg).

**Power:** 190A: 95 to 130 volts, 60 Hz, 55 watts; 190 AP: 115/230 volts, 50 Hz, 55 watts.

**Price:** HP 190A, AP, \$1075.

### 00590A Inductors

HP 00590A Inductors are designed specifically for use in the Q Circuit of the 190A Q Meter for measuring the radio-frequency characteristics of capacitors, resistors, and insulating materials. They have general usefulness as reference coils and may be used for periodic checks to indicate any considerable change in the performance of the Q meters.

### Specifications, 00590A

HP model	Inductance $\mu$ H	Capacitance pF	Approx. resonant freq. MHz	Approx. Q	Approx. distributed C pF
00590-A1	0.05	95-7.5	70-230	350	1.5
00590-A2	0.1	95-7.5	50-160	320	1.7
00590-A3	0.25	100-7.5	30-100	380	2.3
00590-A4	0.5	80-7.5	25-70	360	2.3
00590-A5	1.0	60-7.5	20-50	350	2.9
00590-A6	2.5	15-8.0	20-30	330	2.9

**Price:** HP 00590A, \$17.75 each; HP 00591A, complete set of six \$95.

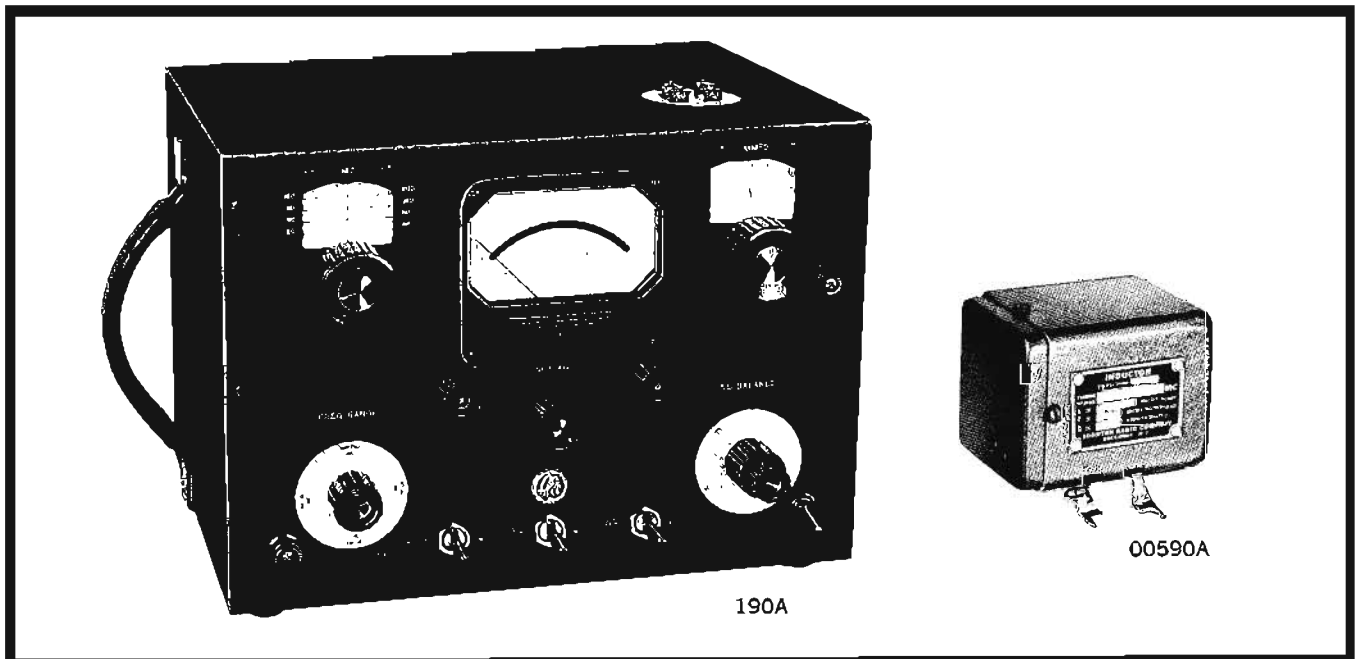

190A

00590A

# SWR, REFLECTION COEFFICIENT MEASUREMENT



## IMPEDANCE

Impedance-matching a load to its source is one of the most important considerations in microwave transmission systems. If the load and source are mismatched, part of the power is reflected back along the transmission line toward the source. This reflection not only prevents maximum power transfer, but also can be responsible for erroneous measurements of other parameters, or even cause circuit damage in high-power applications.

The power reflected from the load interferes with the incident (forward) power, causing standing waves of voltage and current to exist along the line. The ratio of standing-wave maxima to minima is directly related to the impedance mismatch of the load. The standing-wave ratio (swr), therefore, provides a valuable means of determining impedance and mismatch.

### Slotted line measurements

Standing-wave ratio can be measured directly using a slotted line. Until recently, slotted line measurements were limited to fixed frequencies in a setup similar to that illustrated in Figure 1.

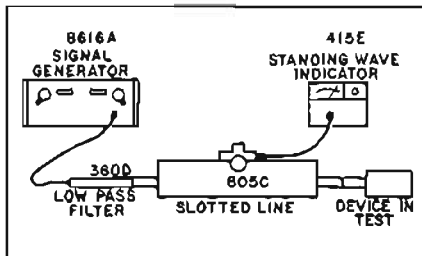

Figure 1. Typical setup for swr and impedance measurements in coax using HP 805C Slotted Line.

The slotted line is placed immediately ahead of the load in test, and the source is adjusted for 1 kHz amplitude modulation at the desired microwave frequency. The slotted line probe is loosely coupled to the RF field in the line, thus sensing relative amplitudes of the standing-wave pattern as the probe is moved along the line. The ratio of maxima to minima (swr) is then read directly on the swr meter.

While this method works very well for fixed-frequency testing, it is very cumbersome for broadband applications. The number of discrete measurements necessary to insure complete coverage across a frequency range is determined by the degree of confidence required that a sharp resonance or hole does not exist, and for a high confidence factor, the number of measurements must be very high.

The solution to broad-band measure-

ments is the swept-frequency technique. This method provides continuous coverage across the frequency range of interest. Measurements of swr of coaxial devices operating below about 2 GHz and waveguide devices is accomplished with the reflectometer (see below). However, the low directivity of coaxial directional couplers operating above 2 GHz seriously limits accuracy in coax at these higher frequencies.

### The swept slotted line

A new technique which combines the speed and convenience of swept-frequency measurements and the inherent accuracy of the slotted line is now available. With the HP 448A Slotted Line Sweep Adapter, 816A Slotted Line, and 809C Carriage, this technique can be used throughout the range from 1.8 to 18 GHz (such a system is illustrated on page 264). The signal source is a sweep oscillator and the readout device is an oscilloscope.

The measurement technique is much the same as for fixed-frequency measurements. A detecting probe is moved along the slotted line a distance of at least one

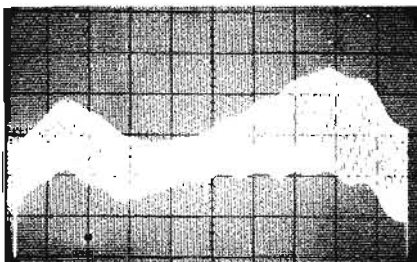

Figure 2. Multi-sweep slotted-line measurement. Vertical scale 0.5 dB/cm (swr=1.12/cm).

half wavelength at the lowest frequency so that both maximum and minimum voltages of the standing waves are sampled. However, instead of the plot being a single vertical line, which would be the case in a fixed-frequency measurement, it is a smear or envelope as shown in Figure 2. At any given frequency, the ratio of the maximum and minimum amplitude of the envelope is the swr.

Measurement of low swr requires sensitive readout devices to resolve the maxima and minima adequately. Therefore, the signal source must be leveled to keep the entire plot on scale. The 448A, comprising a slotted section and two matched detectors, effectively levels the sweeper output and monitors the standing waves in the 816A Slotted Line. No additional probe is required for the 816A.

A storage oscilloscope such as the HP 141A is ideal for these measurements.

The entire plot can be generated in a few seconds and retained on the CRT face for evaluation or photography. Time-exposure photography and a conventional oscilloscope such as the HP 140A can also be used. The HP 1416A Swept-Frequency Indicator, a plug-in for both the 140A and 141A Oscilloscopes, provides additional convenience with its logarithmic calibration. No zero-level reference is needed, and swr is indicated directly in dB when the detector is operated in its square-law region. An X-Y recorder such as the Moseley 7035A can also be used to plot swept swr measurements. The recorder can be driven by an HP 415E SWR Meter, which not only provides ample gain but permits direct calibration of the recorder.

The 816A is equally well suited to fixed-frequency measurements. Using the 447B Untuned Probe, frequencies from 2.6 to 18 GHz are covered. The HP 415E SWR Meter, with its increased sensitivity due to low noise, is direct reading in swr. Slotted sections are also available in the standard waveguide frequency bands from 2.6 to 40 GHz.

Accuracy of slotted-line measurements is limited primarily by the residual swr of the line itself, 1.01 in waveguide and 1.02 to 1.06 in coax depending upon the frequency and type of connector. However, there are other considerations. Penetration of the detector probe into the line should be kept to a minimum to prevent standing waves due to the probe itself. Elimination of harmonics from the signal source is also important. HP 360, 362, and 8430 filters are excellent for this purpose.

### Reflectometer techniques

The reflection coefficient ( $\rho$ ) of a device or system is another useful term in establishing the impedance match of microwave devices. The following relationships of  $\rho$  and swr are frequently used in impedance work:

$$|\rho| = \frac{E_{\text{reflected}}}{E_{\text{incident}}} = \frac{\text{swr} - 1}{\text{swr} + 1}$$

The amplitude of reflected voltage with respect to the incident voltage is given in terms of dB return loss by the expression:  $\text{dB} = -20 \log_{10} \rho$ . For example, if the reflected signal from a test device is 26 dB below the incident signal level, the reflection coefficient of the device is calculated as 0.05. In a like manner, any reflection coefficient from zero to one can be determined by a measure of the return loss.

The reflection coefficient of a load can





be measured by separating the incident and reflected waves propagated in the transmission line connecting the source and load. The reflectometer uses directional couplers to accomplish this separation in both waveguide and coaxial systems. Reflectometers permit continuous oscilloscope displays or permanent x-y recordings of reflection coefficient across complete operating bands.

Incident power in the improved reflectometer is held constant by the leveling action of the sweep oscillator and crystal detector sampling the incident wave from the forward coupler. With incident power held constant, only the relative amplitude of the reflected wave need be measured to determine reflection coefficient. This technique permits better accuracy than older systems, and fast sweep speeds enabling the use of oscilloscope displays.

#### Reflectometer calibration

To calibrate the reflectometer, a short circuit is placed at the output port, thus reflecting all of the incident power. The detector in the reverse-arm coupler samples the reflected power and provides a proportional dc voltage for readout. By placing a calibrated attenuator ahead of the detector, specific amounts of return loss may be pre-inserted for calibration of the oscilloscope or recorder gain. The attenuator is then returned to zero, the short removed and the test device connected and measured on the pre-calibrated display.

Calibration also is possible without the pre-insertion attenuator if the detector law is known and the vertical response of the readout device constant. Calibration levels with this technique are established with the rf turned off (corresponding to no reflection), then with all of the power reflected by a sliding short. Reflections falling between these limits are then read from the oscilloscope graticule or directly from calibrated transparent overlays such as furnished with HP Application Note 65. The HP 140A Oscilloscope with its 1416A plug-in eliminates the need for overlays. With logarithmic calibration, the 140A/1416A provides return loss directly in dB. Complete instructions are included in Application Note 65, available from any HP Field Office upon request.

#### Reflectometer calculator

Time-consuming calculations of return loss and conversion of  $\rho$  to SWR may be eliminated by using an HP Reflectometer

Calculator. This slide-rule-type aid provides continuous scales of  $\rho$ , SWR and return loss, which may be positioned under a cursor for instant conversion of terms. Other useful information such as ambiguity in reflectometer measurements, mismatch loss and phase and amplitude mismatch errors are included on the calculator. It may be obtained from your HP field engineer upon request.

#### Reflectometer errors

The overall measurement accuracy of leveled reflectometer systems such as described here may be closely approximated by considering the various sources of error separately, then taking the rms average. These errors may be classified as being due to imperfect components comprising the reflectometer as follows:

- 1) directional couplers
- 2) detectors
- 3) attenuator used in calibration
- 4) display or readout instrument

One of the primary errors introduced by directional couplers is the directivity signal. Directivity of a coupler refers to its ability to distinguish between forward and reverse power flowing in the main arm. Since reflectometry is based on the separation of incident and reflected power by use of the directional couplers, high directivity is essential to accurate measurements. Any incident power passing to the reverse coupler auxiliary output (because of imperfect directivity) will add in unknown phase with the actual reflected signal from the load in test. The result is an ambiguity in the voltage level at the reverse coupler output. The ambiguity caused by reverse coupler directivity can be determined in terms of reflection coefficient by substituting the directivity (in dB) into the return loss equation given earlier. Thus, for a reverse coupler directivity of 40 dB, the ambiguity in  $\rho$  is  $\pm 0.01$ . For 20 dB directivity, ambiguity is  $\pm 0.1$ , etc. The ambiguity caused by the forward coupler directivity also must be considered, particularly when measuring large reflections. If directivity is not infinite, part of the signal reflected from the test load will appear at the auxiliary arm output of the forward coupler. This directivity signal adds vectorially with the incident signal, producing an ambiguity in the incident power level. The ambiguity is proportional to the magnitude of load reflection and forward coupler directivity and may be calculated as follows:

$$\Delta\rho = \pm\rho \left( \log^{-1} \frac{\text{dB}}{20} \right)$$

where dB = coupler directivity  
 $\rho$  = reflection coefficient of test load.

Primary factors to be considered in the detectors are frequency response, deviation from square law and mismatch. Using hp 423A or 424A Crystal Detectors, frequency response is typically flat to within  $\pm 0.2$  dB per octave and deviation from square law less than  $\pm 0.2$  dB over a 20 dB dynamic range. These two errors can be evaluated in terms of reflection coefficient ambiguity by alternately adding and subtracting the dB values to the return loss actually measured. The errors caused by these two factors can be eliminated by using the pre-insertion attenuator for initial system calibration. Error due to mismatch between HP 752 Waveguide Couplers and 424A Detectors is typically less than  $\pm 3\%$  of the  $\rho$  measured. This includes the total effects of detector mismatch in the incident coupler used for leveling feedback and the reverse arm measuring reflected voltage from the load.

The use of a pre-insertion attenuator for calibration eliminates some detector errors but introduces error of its own. The dial accuracy of the attenuator and mismatch considerations lead to the following expression for the error introduced in the measured reflection coefficient:

$$\Delta\rho = \rho(1 - \rho^{20.02} \pm 0.015)$$

where  $\rho$  = reflection coefficient of the test load.

When the attenuator is not used for calibration, the readout or display device causes error in the measured  $\rho$ . The effects of non-linearity, instability and resolution are factors which must be considered. When using HP 130C or 140A Oscilloscopes for measuring small ratios ( $\approx 1$ ), accuracies of 2% are reasonable. Ratios of 30 dB ( $\rho \approx 0.03$ ) can be determined with about 4% accuracy.

The total effects of these errors can be conservatively estimated as follows using the HP equipment mentioned:

1. Using the 382A attenuator pre-insertion technique,  $\Delta\rho = \pm(0.01 + 0.05\rho)$ .
2. Using the straightforward oscilloscope technique,  $\Delta\rho = \pm(0.011 + 0.04\rho)$ .

A more complete discussion and error analysis of reflectometer systems is included in HP Application Note 65, "Swept Frequency Techniques."

## SWR METER

Reduced noise for greater usable range  
Model 415E



# IMPEDANCE

The Hewlett-Packard Model 415E SWR Meter is a low-noise tuned amplifier-voltmeter calibrated in dB and swr for use with square-law detectors. It is an extremely useful and versatile instrument, measuring swr, attenuation, gain, or any other parameter determined by the ratio of two signal levels. The standard tuned frequency is 1000 Hz and is adjustable over a range of about 7% for exact matching to the source modulation frequency. Amplifier bandwidth is also adjustable, from 15 to 130 Hz. The narrow bandwidth facilitates single-frequency measurements by reducing noise, while the widest setting accommodates a sweep rate fast enough for oscilloscope presentation.

The 415E has a very low noise figure, less than 4 dB. This represents a 6 to 10 dB improvement over other swr meters. Equally significant is the fact that the noise figure has been optimized for source impedances presented by detectors most often used with swr meters. As a result the 415E has greater measurement range because the reduction in noise permits the measurement of lower-level signals for a given signal-to-noise ratio.

A precision 60-dB attenuator with an accuracy of 0.05 dB/10 dB assures high accuracy in attenuation measurements. In addition, an expand-offset feature allows any 2-dB range to be expanded to full scale for maximum resolution. Linearity on the expanded ranges is  $\pm 0.02$  dB, permitting full utilization of the increased resolution; high accuracy is possible on the normal scales as well, for linearity is limited only by meter resolution. The meter itself has individually calibrated, mirror-backed scales plus a rugged taut-band movement for full realization of the inherently high accuracy, resolution, and linearity of the instrument.

The Model 415E operates with either crystal or bolometer detectors. Both high- and low- impedance inputs are available for crystal detectors, optimum crystal source impedances being 50 to 200 and 2500 to 10,000 ohms respectively. For operation with bolometers, the 415E provides precise bias currents of 4.5 and 8.7 mA into 200 ohms, as selected at the front panel. This bias is peak limited for positive bolometer protection.

Both ac and dc outputs are provided for use of the 415E as a high-gain tuned amplifier and with recorders. The solid-state 415E can be operated with an internally mounted battery pack (optional extra) for completely portable use or to eliminate ground loops.

### Specifications

**Sensitivity:** 0.15  $\mu$ V rms for full-scale deflection at maximum bandwidth (1  $\mu$ V rms on high impedance crystal input).

**Noise:** at least 7.5 dB below full scale at rated sensitivity and 130 Hz bandwidth with input terminated in 100 or 5000  $\Omega$ ; noise figure less than 4 dB.

**Range:** 70 dB in 10- and 2-dB steps.

**Accuracy:**  $\pm 0.05$  dB/10-dB steps; maximum cumulative error between any two 10-dB steps,  $\pm 0.10$  dB; maximum cumulative error between any two 2-dB steps,  $\pm 0.05$  dB; linearity,  $\pm 0.02$  dB on expand scales, determined by inherent meter resolution on normal scales.

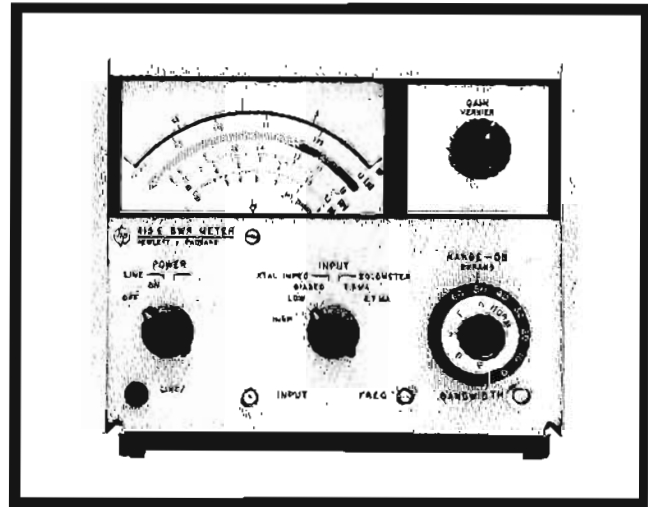

**Input:** unbiased low and high impedance crystal (50-200 and 2500-10,000  $\Omega$  optimum source impedance respectively for low noise); biased crystal (1 V into 1 k $\Omega$ ); low and high current bolometer (4.5 and 8.7 mA  $\pm 3\%$  into 200  $\Omega$ ), positive bolometer protection; input connector, BNC female.

**Input frequency:** 1000 Hz adjustable 7%; other frequencies between 400 and 2500 Hz available on special order.

**Bandwidth:** variable, 15-130 Hz; typically less than 0.5 dB change in gain from minimum to maximum bandwidth.

**Recorder output:** 0-1 V dc into an open circuit from 1000  $\Omega$  source impedance for ungrounded recorders; output connector, BNC female.

**Amplifier output:** 0-0.3 V rms (Norm), 0-0.8 V rms (Expand) into at least 10,000  $\Omega$  for ungrounded equipment; output connector, dual banana jacks.

**Meter scales:** calibrated for square-law detectors; SWR: 1-4, 3.2-10 (Norm); 1-1.25 (Expand). dB: 0-10 (Norm); 0-2.0 (Expand); battery: charge state.

**Meter movement:** taut-band suspension, individually calibrated mirror-backed scales; expanded dB and swr scales greater than  $4\frac{1}{4}$  in. (108 mm) long.

**RFI:** conducted and radiated leakage limits are below those specified in MIL-I-6181D.

**Power:** 115-230 V  $\pm 10\%$ , 50-400 Hz, 1 W; optional rechargeable battery provides up to 36 hr continuous operation.

**Dimensions:**  $7\frac{25}{32}$  in. wide,  $6\frac{3}{32}$  in. high, 11 in. deep from panel (190 x 155 x 279 mm).

**Weight:** net,  $7\frac{7}{8}$  lb (3.5 kg),  $9\frac{7}{8}$  lb (4.4 kg) with battery; shipping, 11 lb (5 kg), 13 lb (6.3 kg) with battery.

**Accessory available:** 11057A Handle, fits across top of instrument for carrying convenience, \$5.

**Combining cases:** 1051A,  $11\frac{1}{4}$  in. (286 mm) deep, \$110; 1052A,  $16\frac{3}{4}$  in. (416 mm) deep, \$120.

**Price:** HP Model 415E, \$350.

**Options:** 01. rechargeable battery installed, add \$100; 02. rear-panel input connector in parallel with front-panel connector, add \$15.



## SWR INDICATOR; MOUNTS

For convenient swr measurements

Models 415B; 476A, 485B

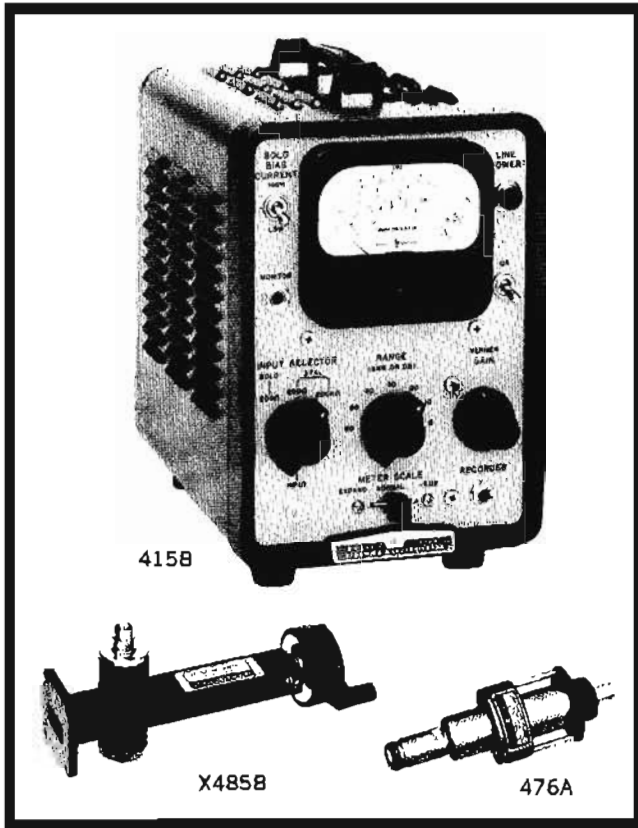

415B

X485B

476A

### 415B Standing Wave Indicator

Similar to the HP 415E, this meter is a tuned voltmeter for swr measurements with HP slotted lines and detector mounts. It also is useful as a null indicator for bridge measurements, with a 200 k $\Omega$  input circuit for this use.

A 60 dB attenuator adjustable in 10 dB range steps provides a calibrated range of 70 dB. An output is provided for use with a recording milliammeter, and a special 5 dB attenuator is incorporated to increase resolution through use of the upper portion of the logarithmic meter scale.

Inputs include a 200-ohm termination with bias of 4.3 or 8.7 mA for bolometers, unbiased for crystals, or a 200 k $\Omega$  load for null measurements. A jack and monitor cable are provided for connecting an external milliammeter to measure bolometer current.

### Specifications, 415B

**Input:** "Bolo" (200 ohms), bias provided for 8.7 or 4.3 mA bolometer or 1/100 amp fuse; "Crystal" (200 ohms) for crystal rectifier; "Crystal" (200 k $\Omega$ ) high impedance for crystal rectifier as null detector; BNC connector.

**Sensitivity:** 0.1  $\mu$ volt at 200 ohms for full-scale deflection.

**Noise:** at least 5 dB below full scale when operated from 200-ohm resistor at room temperature.

**Frequency:** 1000 Hz  $\pm$  2%; other frequencies, 315 to 2020 Hz, available on special order; should not be harmonically related to power line frequency.

**Bandwidth:** 30 Hz (nominal).

**Range:** 70 dB; input attenuator provides 60 dB in 10 dB steps, accuracy  $\pm$ 0.1 dB per 10 dB step; maximum accumulative error,  $\pm$  0.2 dB.

**Scale selector:** "Normal", "Expand" and " $-5$  dB".

**Output:** jack provided for recording milliammeter having 1 mA full-scale deflection and internal resistance of 1500 ohms or less.

**Meter scales:** swr 1 to 4, swr 3 to 10, expanded swr 1 to 1.3; dB 0 to 10, expanded dB 0 to 2.

**Power:** 115 or 230 volts  $\pm$  10%, 50 to 60 Hz, 55 watts.

**Dimensions:** cabinet: 7 $\frac{1}{2}$ " wide, 11 $\frac{3}{4}$ " high, 12 $\frac{1}{2}$ " deep (191 x 299 x 318 mm); rack mount: 19" wide, 6-31/32" high, 10 $\frac{7}{8}$ " deep behind front panel (483 x 177 x 276 mm).

**Weight:** net 13 lbs (5.9 kg), shipping 15 lbs (6.8 kg) (cabinet); net 17 lbs (7.7 kg), shipping 27 lbs (12.2 kg) (rack mount).

**Accessories available:** plug-in filters (specify frequency): 415B-42B (315 to 699 Hz), \$60, and 415B-42C (700 to 2000 Hz), \$50; 10501A Cable Assembly, \$3.50; 10503A Cable Assembly, \$6.50.

**Price:** HP 415B, \$275 (cabinet); HP 415BR, \$280 (rack mount).

### 476A Bolometer Mount

Model 476A Bolometer Mount covers the 10 MHz to 1 GHz frequency range with very low standing wave ratio. The inherently good square law characteristics of the bolometers used make the 476A especially useful for calibrating attenuators when used with an HP 415 Series Meter.

### Specifications, 476A

**Nominal impedance:** 50 ohms.

**Reflection coefficient:** 50 to 500 MHz,  $\leq$  0.07 (1.15 swr, 23.1 dB return loss); 25 to 1000 MHz,  $\leq$  0.11 (1.25 swr, 19.1 dB return loss); 10 to 25 MHz,  $\leq$  0.2 (1.5 swr, 14 dB return loss).

**Maximum power level:** 10 mW.

**Bolometer element:** four 8.25 mA instrument fuses (supplied with mount); operating level is approximately 200 ohms, positive temperature coefficient.

**Replacement elements:** Part #2110-0024, \$1 each.

**Weight:** net 1 lb (0.5 kg); shipping 2 lbs (0.9 kg).

**Price:** HP 476A, \$85.

### 485B Detector Mounts

The HP 485B Detector Mounts (5.3 to 12.4 GHz) permit the accurate matching of waveguide sections to a bolometer element. The mounts are tuned by a variable short, and they can be used with a barretter or, where swr is not critical, with a silicon crystal.

### Specifications, 485B

HP Model	Frequency range (GHz)	Maximum swr <sup>1</sup>	Fits waveguide size		Length		Price
			(In.)	(EIA)	(In.)	(mm)	
J485B2	5.85 - 8.2	1.25	1 $\frac{1}{2}$ x $\frac{3}{8}$	WR137	8 $\frac{3}{8}$	213	\$120
	5.50 - 5.85	1.35					
	5.30 - 5.50	1.50					
H485B2	7.05 - 10	1.25	1 $\frac{1}{4}$ x $\frac{3}{8}$	WR112	6 $\frac{3}{8}$	162	\$100
X485B2	8.2 - 12.4	1.25	1 x $\frac{1}{2}$	WR90	6-7/16	163	\$ 75

<sup>1</sup>With Narda N821 barretter

<sup>2</sup>May use 1N21 or 1N23 for maximum detection sensitivity where swr is not critical

Detector elements are not supplied

# RATIO METER

## Simplified reflection coefficient measurements

### Model 416B



# IMPEDANCE

#### Advantages:

- Eliminates amplitude-variation error
- Operates accurately over 20/1 incident power range

#### Use:

- Reflection coefficient measurements over broad frequency range, independent of rf power level

The HP 416B is designed for use with unlevelled sweep oscillators and signal sources in the measurement of reflection coefficient. The ratio meter provides valid results inde-

pendent of incident power variations as high as 20:1. Either swept- or fixed-frequency measurements can be made using the Model 416B, and a high-impedance output on the rear of the instrument permits swept-frequency measurements to be presented on an oscilloscope or preserved on a graphic recorder. The panel meter is calibrated in percent reflection and equivalent swr.

The 416B operates with either crystals or bolometers, and a panel switch permits selection of 4.3 or 8.7 mA bias for bolometers. Positive bolometer protection is provided.

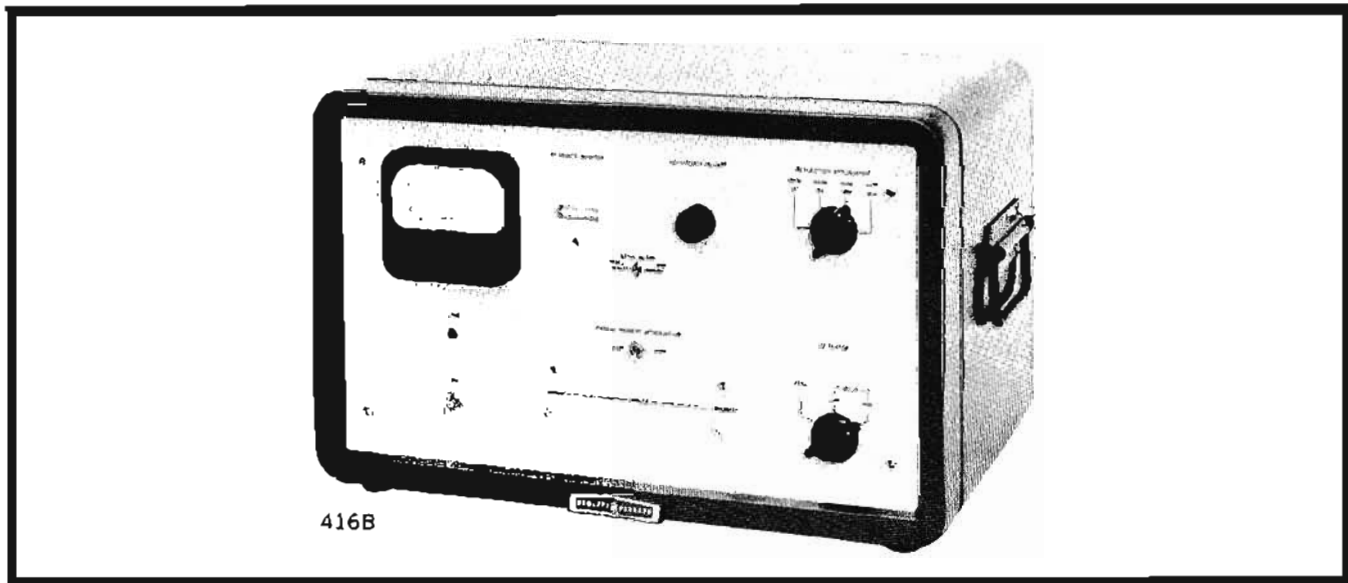

### Specifications

#### Meter presentation

**Reflection coefficient (%):** four ranges, 100%, 30%, 10% and 3% reflection, equivalent to reflection coefficients of 1, 0.3, 0.1 and 0.03.

**Equivalent swr:** two ranges, 1.06 to 1.22 and 1.2 to 1.9.

**dB:** for use with both reflection coefficient and equivalent swr scales; scale calibrated 0 to -10 dB; with ranging, spans 0 to -40 dB in four 10-dB steps.

**Accuracy:** crystal,  $\pm 3\%$  of full scale; bolometer, same as crystal except  $\pm 5\%$  for incident input voltage below 1 mV.

**Calibration:** square law for use with crystal detectors or barretters.

**Frequency:** 1000 Hz  $\pm 40$  Hz ( $\pm 20$  Hz for bolometer detectors when incident input voltage is  $< 1$  mV rms).

**Input voltage (for full-scale deflection):**

	Crystal	Bolometer
Incident channel	3 to 100 mV rms	0.3 to 10 mV rms
Reflected channel	3 $\mu$ V to 100 mV rms	0.3 $\mu$ V to 10 mV rms

**Input impedance (both channels):** crystal, approximately 75 k $\Omega$ ; bolometer, approximately 500 ohms (High Bolo) or 1000 ohms (Low Bolo).

**Excess incident attenuation:** provision for 10 dB increase of incident channel sensitivity for reflectometers using couplers with different coefficients; under certain circumstances, accuracies can be improved by this procedure.

#### Output

**Open circuit voltage:** approx. 10 V dc at full scale.

**Source impedance:** 100 k $\Omega$ ; BNC type connector.

**Bolo bias:** high range, 8.7 mA; low range, 4.3 mA; bias variable approximately 10% by means of rear-panel control; positive bolometer protection.

**RF power monitor:** level indicator monitors input amplitude (and frequency, indirectly) to assure proper operating range for the instrument and for crystal detectors.

**Power:** 115 or 230 volts  $\pm 10\%$ , 50 to 60 Hz, 115 watts.

**Dimensions:** cabinet: 20 $\frac{3}{4}$ " wide, 12 $\frac{3}{4}$ " high, 14 $\frac{7}{8}$ " deep (527 x 324 x 378 mm); rack mount: 19" wide, 10 $\frac{1}{2}$ " high, 14" deep behind panel (483 x 267 x 356 mm).

**Weight:** net 34 lbs (15,3 kg), shipping 45 lbs (20,3 kg) (cabinet); net 28 lbs (12,6 kg), shipping 41 lbs (18,5 kg) (rack mount).

**Accessories available:** 10503A Cable Assembly, \$6.50; 11001A Cable Assembly, \$5.50.

**Price:** HP 416B, \$590 (cabinet); HP 416BR, \$575 (rack mount).



## SLOTTED LINES; DETECTORS

Precision tools for measurements to 40 GHz

Models 809C-816A; 440A-447B, 448A

### 805C Slotted Line, 500-4000 MHz

Model 805C is a coaxial slotted line with an integral probe circuit tunable from 500 to 4,000 MHz. The slotted line consists of two parallel planes and a rigid center connector. This configuration results in negligible slot radiation, minimum sensitivity to variation in probe depth or centering, and greater structural stability.

#### Specifications, 805C

**Frequency range:** 500 to 4,000 MHz; minimum frequency determined by usable length of 14½ in. (368 mm).

**Impedance:** 50Ω; 1.04 swr.

**Connectors:** Type N, one male, one female; either end may be connected to the load.

**Calibration:** metric, cm and mm; vernier reads to 0.1 mm.

**Detector probe:** tunable; element may be 1N21B Crystal (supplied) or 821 Series Barretter or selected 1/100-amp instrument fuse.

**Accessories furnished:** 11511A female short; 11512A male short.

**Price:** HP 805C, \$550.

### 816A Coaxial Slotted Section, 1.8-18 GHz

The 816A enables you to make swept-frequency slotted line measurements from 1.8 to 18 GHz in coaxial systems (HP 448A is required; see below). High accuracy is assured with the low residual swr of the 816A. Thus, you can take advantage of the complete coverage offered by the swept-frequency technique. Fixed-frequency measurements from 2.6 to 18 GHz can also be made using HP 447B Probe (see below). With its broad frequency range, the 816A covers the extremely important X-band (8.2 to 12.4 GHz). In addition, it extends the range of coaxial slotted line measurements through P-band (12.4 to 18 GHz), where there is an increasing use of coaxial devices.

Model 816A consists of two parallel planes and a rigid center conductor. This configuration virtually eliminates slot radiation and minimizes the effect of variation in probe penetration and centering. It also provides greater mechanical stability. The 816A is fitted with one APC-7 and one Type N female connector. On an optional basis, the APC-7 can be replaced with a Type N male connector, or both connectors can be APC-7's. Other combinations are available on special order.

#### Specifications, 816A

**Carriage:** fits HP 809C Carriage.

**Frequency range:** 1.8 to 18 GHz (depends upon probe).

**Impedance:** 50Ω ± 0.2Ω.

**Connectors:** one APC-7, one Type N female; either end can be connected to the load; shorting connectors furnished for load phase angle determination.

**SWR:** APC-7 connector 1.02 to 8 GHz, 1.03 to 12.4 GHz, 1.04 to 18 GHz; Type N female connector: 1.03 to 8 GHz, 1.04 to 12.4 GHz, 1.06 to 18 GHz.

**Slope and irregularities:** 0.1 dB maximum.

**Length:** 9¾ in. (248 mm).

**Weight:** net 1¼ lbs (0,6 kg); shipping 3 lbs (1,4 kg).

**Accessories furnished:** 11512A Type N male short; 11565A APC-7 short.

**Price:** HP 816A, \$250.

**Option 11:** both connectors APC-7, add \$25.

**Option 22:** Type N male connector in lieu of APC-7, less \$15.

### 448A Slotted Line Sweep Adapter, 1.8-18 GHz

The HP 448A permits accurate swept-frequency swr measurements in coax from 1.8 to 18 GHz with the 816A Slotted Section. (See pages 255, 256 for a discussion of swept-frequency slotted line measurement techniques.) The 448A includes a short slotted section and two matched detectors with adjustable probes. One detector fits in the slotted section of the 448A, and its output levels the signal source, a sweep oscillator such as the HP 8690A. The other detector monitors the standing waves in the HP 816A Slotted Section.

#### Specifications, 448A

**Frequency range:** 1.8 to 18 GHz.

**Equipment supplied:** one fixed slotted section, one pair of matched detectors with adjustable probes.

**Connectors:** slotted section, Type N, one male, one female; detectors, BNC female.

**Slotted section:** HP 816A mounted in HP 809C Carriage.

**Weight:** net 14 oz (0,39 kg); shipping 2 lbs (0,9 kg).

**Price:** HP 448A, \$400.

### 810B, 815B Slotted Sections, 3.95-40 GHz

The 810B Waveguide Slotted Sections also are designed for use with the 809C Carriage. Each is a precision-manufactured section of waveguide in which a small longitudinal slot is cut. A traveling probe on the 809C Carriage samples the waveguide's electric field along the slot and permits precise plotting of variations along the entire length of probe travel. Ends of the slots are tapered to reduce swr to less than 1.01. The waveguide sections are broached and checked with precision gauges for careful control of guide wavelength. Broaching is essentially a linear cutting stroke which eliminates even the minor surface irregularities inherent with milling cutters. Six waveguide sizes are available.

The 815B Waveguide Slotted Sections are designed to fit the 814B Carriage. Like the lower-frequency slotted sections, each 815B is precision-manufactured, broached and checked with precision gauges for careful control of guide wavelength. The slot is tapered to insure a low swr.

#### Specifications, 810B

HP Model	Frequency range (GHz)	Fits waveguide size		Equivalent flange	Price
		nom. OD (in.)	EIA		
G810B	3.95-5.85	2 x 1	WR187	UG407/U	\$140
J810B	5.30-8.20	1½ x ¾	WR137	UG441/U	\$125
H810B	7.05-10.0	1½ x ¾	WR112	UG138/U	\$110
X810B	8.20-12.4	1 x ½	WR90	UG135/U	\$ 90
P810B	12.4-18.0	0.702 x 0.391	WR62	UG419/U	\$110

**Carriage:** fits 809C Carriage.

**Length of all sections:** 10¼" (260 mm).

**Slope and irregularities:** slot discontinuity results in swr < 1.01.

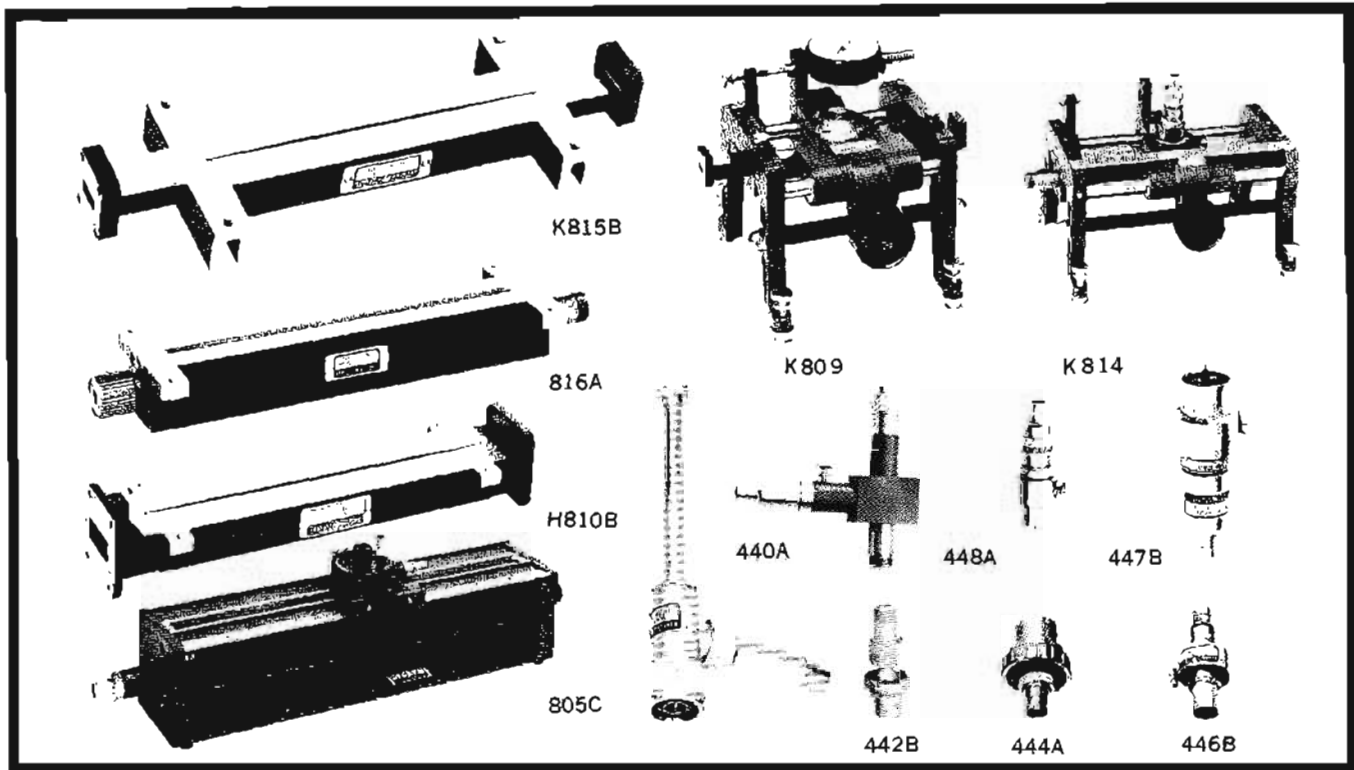

### Specifications, 815B

	HP K815B	HP R815B
Frequency range (GHz):	18 to 26.5	26.5 to 40
Residual swr:	1.01	1.01
Equivalent flange:*	UG595/U	UG599/U
Fits waveguide size:	(in.) 1/2 x 1/4 (EIA) WR42	0.360 x 0.220 WR28
Overall length:	7-9/16" (192 mm)	7-9/16" (192 mm)
Price:	\$350	\$400

\*Circular flange adapters: K-band (UG425/U) 11515A, \$35 each; R-band (UG381/U) 11516A, \$40 each.

### 809C, 814B Carriages

Model 809C Carriage is a precision mechanical assembly which operates with five HP 810B Waveguide Slotted Sections (3.95 to 18 GHz) and with HP 816A Coaxial Slotted Section (1.8 to 18 GHz). The carriage eliminates the cost of a probe carriage for each frequency band. Sections can be interchanged in seconds. The 809C is designed for use with the HP 444A or 447B Untuned Probe, the HP 442B Broadband Probe, or 448A Slotted Line Sweep Adapter. The carriage has a centimeter scale with a vernier reading to 0.1 mm, and provision also is made for mounting a dial gauge if more accurate probe position readings are required. Price: HP 809C, \$200.

The HP 814B Carriage, also a precision assembly, is designed for use with the HP K and R815B Waveguide Slotted Sections (18 to 40 GHz) and HP 446B Untuned Probe. The carriage is equipped with a dial indicator for accurate reading. Slotted sections are easily interchanged. Price: HP 814B, \$225.

### 440A Detector Mount

The HP 440A is a tunable, easy-to-use instrument for detecting rf energy in coaxial systems (2.4 to 12.4 GHz) or, in conjunction with the HP 442B, in waveguide or coaxial slotted sections. Just one adjustment is required for tuning. Crystals or bolometers may be used interchangeably in the same holder. A built-in rf bypass is provided. The detector (not supplied) can be a 1N21 or 1N23 Crystal or 821

Series Barreter. Input connector is Type N male; detector output BNC female. Price: HP 440A, \$85.

### 442B, 444A, 446B, 447B Probes

Model 442B is a probe whose depth of penetration into a slotted section is variable. Held in position by friction, it may be fixed in place by a locking ring. Sampled rf appears at a Type N jack, permitting direct connection to a receiver, spectrum analyzer or other instrument. It can be connected to a 440A Detector Mount to form a sensitive and convenient tuned rf detector for slotted waveguide sections. The 442B fits the 809C Carriage. Price: HP 442B, \$50.

The 444A Untuned Probe consists of a crystal, plus a small antenna in a convenient housing. The probe is held in position by friction or may be fixed by a locking ring. No tuning is required, and sensitivity equals or exceeds many elaborate single- and double-tuned probes. The 444A fits the 809C Carriage or other carriages with a 3/4" (19 mm) mounting hole. Frequency range is 2.6 to 18 GHz. Price: HP 444A, \$55.

The HP 446B is a broadband detector and probe which consists of a modified 1N53 silicon diode in a carefully designed shielded housing. No tuning is required, and probe penetration may be varied quickly and easily. Designed for use with the 814B Carriage, the 446B has a frequency range of 18 to 40 GHz. Price: HP 446B, \$145.

Model 447B consists of a crystal diode detector plus a small antenna probe for sampling energy in coaxial and waveguide slotted sections. The Untuned Probe is extremely sensitive over its entire frequency range of 2.6 to 18 GHz. Such performance is achieved through the use of a unique crystal diode package developed by Hewlett-Packard. With its broad frequency range and high sensitivity, the 447B is ideal for use with HP 816A Coaxial Slotted Section. The Untuned Probe fits HP 809C Carriage or other carriages with a 3/4" (19.1 mm) mounting hole. Price: HP 447B, \$125.





## Coaxial instrumentation

Hewlett-Packard offers a line of coaxial accessories for measurement of swr, attenuation, noise figure, frequency, and other microwave measurements from dc to 18 GHz. Included in the product line are single and dual directional couplers, thermistor mounts for power meters, frequency meters, slotted lines, pads, loads, filters, and other devices useful in microwave measurements.

## Couplers

Flat frequency response couplers, Models 796D-798C, are offered with high directivity for minimizing errors in swept swr reflectometry systems. Flat couplers are also very useful for leveling sweep oscillators. Also, they can be used to monitor power out of signal sources. The flat frequency response allows the coupler to extend the power range of power meters over broad frequency bands. Dual-directional couplers, Models 774D-777D, are available from 215 MHz to 4000 MHz. Model 778D is a new wide-band coupler covering the frequency range from 100 MHz to 2000 MHz. It is useful in applications for testing coaxial devices, where the frequency range is usually much greater than an octave. Directivity of this coupler exceeds 40 dB to 1000 MHz, 34 dB to 2000 MHz.

## Detectors

For detection of signals, 423A and 8470A Crystal Detectors, with flat frequency response from 10 MHz to 12.4 and 18 GHz respectively, offer the optimum in detectors for swept swr and attenuation measurements. These detectors are ideal for sweep oscillator leveling applications because of their very flat frequency response. Also, the flat frequency response of the individual detectors eliminates the need for matched pairs of detectors in most applications. However, selected pairs can be provided with extremely well matched frequency response characteristics if required.

## Thermistor mount

Hewlett-Packard Model 478A is a temperature compensated thermistor mount used with the HP 431B and 431C Power Meters over the frequency range 10 MHz to 18 GHz. Each mount is calibrated for rf efficiency at several points over the band so that power measurements can be made with the utmost accuracy. In addition, each mount is swept tested over critical parts of the band to

insure that its rf efficiency does not contain "holes" or resonances over the instrument's bandwidth. A swept frequency test is also made of swr so that mismatch ambiguities can be also kept to a minimum.

## Frequency meters

Two coaxial frequency meters, Models 536A and 537A, covering the range from 0.96 to 12.4 GHz allow quick and convenient measurement of frequency by the use of the resonant cavity technique. The wavemeter is inserted in the line and tuned until a drop in power is indicated on a detector. The frequency is read directly on a highly visible spiral scale on the wavemeter.

## Slotted lines

Slotted lines covering the frequency range from 500 MHz to 4 GHz and 2 GHz to 18 GHz (Models 805C and 816A) are available for swr measurements. Residual swr is low for highest accuracy. SWR meters, probes, detectors, complete the swr measurement setup.

Slotted Line Sweep Adapter Model 448A is available for measurements of swr by a swept frequency technique using the 816A Slotted Line. This method presents data of swr versus frequency directly on an oscilloscope. High accuracy is inherent from the low residual swr of the slotted line. Swept-frequency slotted line measurements are discussed in detail in Application Note 84. This note is available from any HP Field Office upon request.

## Attenuators

A deposited resistive thin-film technique pioneered at Hewlett-Packard is the heart of new wideband flat frequency response pads and attenuators. (Models 8491A,B and 8492A.) These components cover the frequency range from dc up to 18 GHz. They have excellent frequency response and swr characteristics over this band. Simplified construction techniques and swept frequency testing over this wide range reduces cost so that these precision, quality pads can be provided at a low price.

A full line of these pads is available—3, 6, 10, and 20 dB pads. Higher attenuation values are also available.

These pads are also available with a new APC-7\* connector. These are sexless connectors that have an unambiguous mating plane. The sexless connector reduces wear and eliminates the need for male and female adapters. These con-

nectors have low swr up to a frequency of 18 GHz.

In addition to fixed attenuator pads, a turret attenuator (Model 354A) providing values of 0 to 60 dB in 10 dB steps is available. It is extremely valuable in multi-octave tests in measurements which would otherwise require two or more attenuators. It's also very well suited as an input attenuator for reducing signal drive to mixers or detectors. It operates with a simple knob rotation, i.e., no pull-turn-push sequence is required. These and other coaxial devices are tabulated on pages 264 and 265. Frequency range is indicated for each device, and the page on which each item is fully described is included.



Figure 1. Amphenol APC-7 precision 7-mm coaxial connector.

## Waveguide instrumentation

A full line of waveguide instruments is offered by Hewlett-Packard for the measurement of impedance, swr, attenuation, noise figure, power, and many other microwave measurements. In addition, HP offers components such as waveguide to coax adapters, moving loads and shorts, tuners, low power terminations, etc. These instruments are tabulated by frequency band on the following pages for quick and easy reference. This instrumentation is offered over eight waveguide frequency bands between 2.6 and 40 GHz. Typical operating instrumentation setups are shown in the following pages. In general, the setup shown for one band can be duplicated in other bands.

\*Amphenol Precision Connector—7 mm, manufactured by Amphenol RF Division, a division of Amphenol Corporation, Danbury, Conn.



## Construction

Many of the waveguide instruments are aluminum die cast to take advantage of the dimensional stability and production uniformity that this technique provides. An aluminum die cast allows the use of a broaching technique for cutting the internal waveguide dimensions. A broach is a long cutting bar with teeth all around it that is pulled through the casting to cut the surface. The linear cutting stroke of the broach eliminates even the minor surface irregularities inherent with milling cutters. Whereas, typical tolerances of internal waveguide tubing is  $\pm .003$  inches, precision broaching allows internal dimensions to be controlled to  $\pm .001$  inches or less.

The broaching process is very important for instruments such as slotted lines, high directivity directional couplers, sliding loads, and sliding shorts. Small tolerances on internal waveguide dimensions provide low swr in order that maximum accuracy can be obtained from a waveguide measuring setup.

## Flanges

Each flange on a waveguide instrument is machine lapped after an initial sanding belt preparation of the surface. This lapping process, in addition to providing a very smooth surface to obtain the best possible mating of two pieces, provides a slightly convex surface so that only the innermost area of the mating flanges makes contact. Thus, the tightest possible connection is made between waveguide instruments so that leakage is kept as low as possible.

## Full band testing

Quality is insured when you have HP waveguide instrumentation. Comprehensive tests are made to insure conformance to the published specifications

over the complete frequency range. The concept of full band testing, pioneered by Hewlett-Packard, makes maximum use of swept-frequency techniques. As

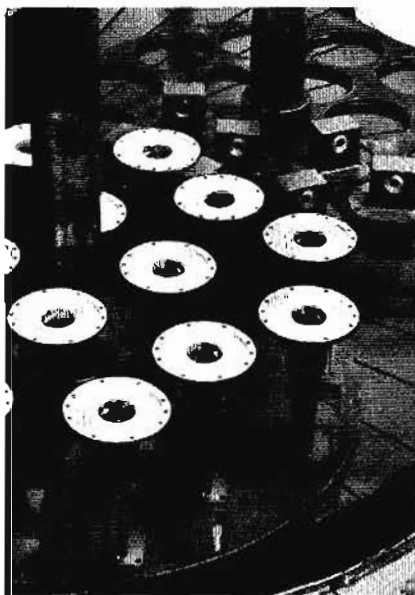

Figure 2. Precise lapping of waveguide flanges insures proper mating.

contrasted with spot frequency testing, a full-band swept test gives a complete record which is continuous over the entire range of the instrument.

Most Hewlett-Packard waveguide instruments are full band tested to eliminate the possibility of any instrument being shipped that does not meet its published specifications over the complete frequency range. The reflectometry concept for swr testing is used almost exclusively at HP for waveguide swr tests. High directivity couplers such as the 752 Series are also swept for directivity, as shown in Figure 3. The directivity in most cases exceeds the 40-dB published specification by a substantial margin.

Hewlett-Packard also provides on special request selected couplers specifically selected to exceed the published directivity specifications over a particular portion of the frequency band.

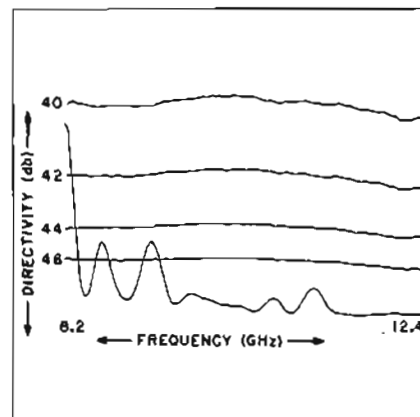

Figure 3. Directivity curve of a X752C.

Testing of precision attenuators is also made with swept-frequency tests. The precision variable attenuator, X382A, is swept tested over its entire frequency and attenuation range.

For more information on swept-frequency techniques, ask for a copy of Application Note 65. This application note describes in detail the theory and actual operating setups to make several swept-frequency microwave measurements. Some of the measurements described are: attenuation, swr, noise figure, cavity Q measurements, wave-meter calibrations, TWT amplifier gain tests, thermistor mount efficiency testing, and waveguide coupler directivity. To obtain a copy of this Application Note contact your nearest HP Sales Office. Locations are listed at the rear of this catalog.

HP	Designations		Dimensions Nominal OD (Inches)	TE <sub>10</sub> operating range			Free-space wavelength (cm)	Theoretical attenuation dB/100 ft. low to high freq.	Theoretical pk power rating megawatts low to high freq.
	EIA	JAN		Frequency (GHz)	Wavelength (cm)	Cutoff freq. (GHz)			
S	WR 284	RG-48/U	3 x 1½	2.60 - 3.95	19.18 - 8.92	2.078	11.53 - 7.59	1.102 - 0.752	2.2 - 3.2
G	WR 187	RG-49/U	2 x 1	3.95 - 5.85	12.59 - 6.08	3.152	7.59 - 5.12	2.08 - 1.44	0.94 - 1.32
J	WR 137	RG-50/U	1½ x ¾	5.30 - 8.20	9.68 - 4.29	4.301	5.66 - 3.66	2.87 - 2.30	0.56 - 0.71
H	WR 112	RG-51/U	1¼ x ¾	7.05 - 10.0	6.39 - 3.52	5.259	4.25 - 3.00	4.12 - 3.21	0.35 - 0.46
X	WR 90	RG-52/U	1 x ½	8.20 - 12.4	6.09 - 2.85	6.557	3.66 - 2.42	6.45 - 4.48	0.20 - 0.29
M	WR 75	-----	0.850 x 0.475	10.0 - 15.0	4.86 - 2.35	7.868	3.00 - 2.00	10.07 - 7.03	0.17 - 0.23
P	WR 62	RG-91/U	0.702 x 0.391	12.4 - 18.0	3.75 - 1.96	9.487	2.42 - 1.67	9.51 - 8.31	0.12 - 0.16
N	WR 51	-----	0.590 x 0.335	15.0 - 22.0	3.11 - 1.60	11.571	2.00 - 1.36	17.3 - 12.6	0.08 - 0.107
K	WR 42	RG-66/U	½ x ¼	18.0 - 26.5	2.66 - 1.33	14.048	1.67 - 1.13	13.3 - 9.5	0.043 - 0.058
R	WR 28	RG-96/U	0.360 x 0.220	26.5 - 40.0	1.87 - 0.88	21.075	1.13 - 0.749	21.9 - 15.0	0.022 - 0.031



The coaxial slotted line system illustrated here is capable of swept-frequency swr measurements from 1.8 to 18 GHz. In this range coaxial directional couplers suffer from low directivity, limiting the accuracy of swept-frequency reflectometers. On the other hand, conventional fixed-frequency slotted-line measurements are slow and tedious. The swept-frequency slotted line system enables you to realize the accuracy of the slotted line and the complete coverage and time saving of swept-frequency testing.

The system illustrated is set up for measurements in P-band (12.4 to 18 GHz). Measurements in other bands can be made by changing the RF Unit in the 8690A Sweep Oscillator. The HP 141A Oscilloscope is the ideal readout device; the entire plot can be generated in a few seconds and retained on the crt face for evaluation or photography. The HP 1416A Swept-frequency Indicator adds convenience with its logarithmic calibration. No zero-level reference is needed, and swr is indicated directly in dB when the detector is operated in its square-law region.

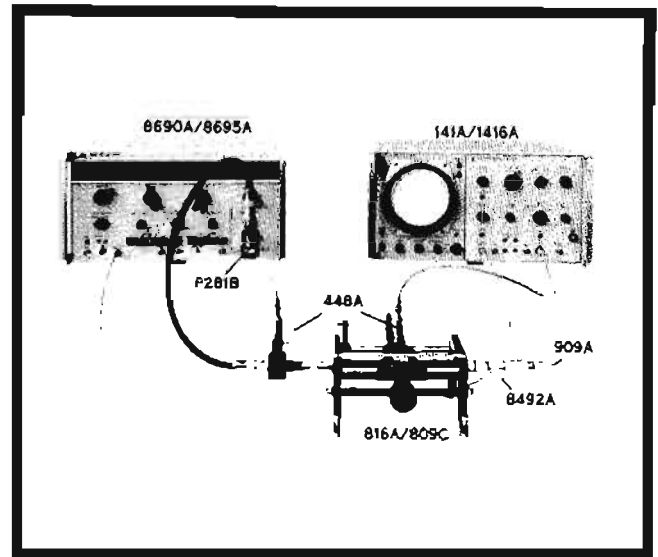

Instrument name	Uses	Frequency coverage by model													Page											
		dc	10 MHz	100 MHz	215 MHz	450 MHz	500 MHz	940 MHz	1 GHz	2 GHz	3 GHz	4 GHz	10 GHz	12.4 GHz		18 GHz										
Waveguide-to-coax adapters	Interconnect waveguide and coaxial systems													← 281A →	← 281B →	279										
Low-pass filters  Bandpass filters	Spectrum analyzer preselectors to eliminate signals outside the range of interest; output filters for signal sources to eliminate harmonics													← 360A →	← 360B →	← 360C →	← 360D →	← 8430A →	← 8431A →	← 8432A →	← 8433A →	← 8434A →	← 8435A →	← 8436A →	272	
Variable attenuators  Fixed attenuators	Measurement of reflection coefficient, insertion loss, transfer characteristics by rf substitution; reduction of power levels; reduction of source mismatch													← 354A →	← 355C →	← 355D →	← 393A →	← 394A →	← 8491A →	← 8491B →	← 8492A →					372
Detectors	RF detection; reflection coefficient, attenuation measurements													← 420A →	← 420B →	← 423A →	← 440A →	← 476A →	← 8470A →							273 260 258 273

# COAXIAL INSTRUMENTATION

For coaxial systems operating to 18 GHz



## COAXIAL, WAVEGUIDE

Instrument name	Uses	Frequency coverage by model													Page
		dc	10 MHz	100 MHz	215 MHz	450 MHz	500 MHz	940 MHz	1 GHz	2 GHz	3 GHz	4 GHz	10 GHz	12.4 GHz	
Thermistor mounts	Power measurements with HP 430C (477B) and HP 431C (478A)												381 378		
Frequency meters	Frequency measurements												530		
Dual directional couplers	Reflectometer measurements; optimizing transmission characteristics of rf systems; power monitoring												274		
Directional detectors	Closed-loop leveling of signal sources; power monitoring												274		
Directional couplers	Power measurements; power leveling												274		
Slotted sections	Measurement of swr, wavelength, impedance, system flatness												260		
Slotted line sweep adapter	Adapter, detector for swept-frequency slotted line measurements												260		
Slide screw tuner	Impedance matching												277		
Terminations	Termination of 50-ohm systems; separation of load and other system reflections (907A)												278		
PIN modulators	Sinusoidal and complex AM and RF pulsing of microwave sources without incidental FM												370		
Harmonic mixer	Mixing SHF and VHF signals														

# COAXIAL, WAVEGUIDE



## WAVEGUIDE INSTRUMENTATION

Quality equipment for microwave measurements  
S-band, 2.60 to 3.95 GHz, and G-band, 3.95 to 5.85 GHz

The swept-frequency system illustrated on the right permits rapid measurement of attenuation (in this example the G375A is being calibrated). The transmission characteristics of the system are accounted for in the initial calibration which is based on the G382A Attenuator.

### Complementary Equipment

HP Instrument	Frequency Range (GHz)	Price
8616A Signal Generator	1.8 to 4.5	\$2100
8616B Signal Source	1.8 to 4.5	\$1450
618C Signal Generator	3.8 to 7.6	\$2250*
8690A Sweep Oscillator		\$1550
8692A RF Unit	2 to 4	\$1700
8692B RF Unit	2 to 4	\$2000
8693A RF Unit	4 to 8	\$1575
8693B RF Unit	4 to 8	\$1900

\*Add \$20 for rack mount

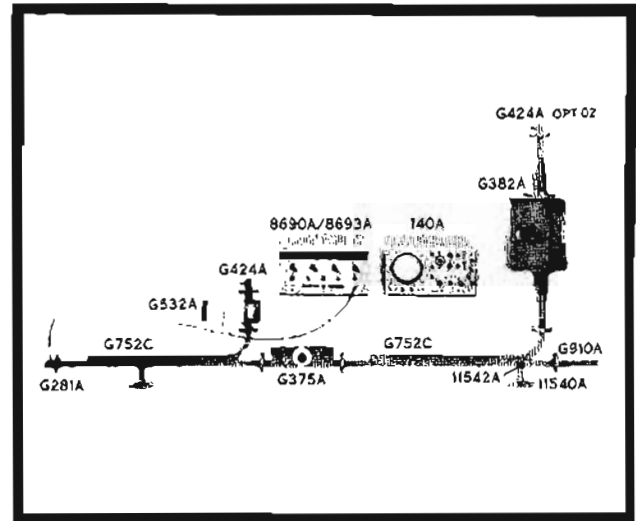

### S- and G-band Equipment

HP Model	Description	Accuracy	Range	SWR (max)	Power (watts)	Length		Page Reference	Price		
						(in)	(mm)				
S281A	Adapter, waveguide-to-coax			1.25		2½	64	279	\$50		
G281A						2½	54	279	\$40		
S347A	Noise source, waveguide	± 0.5 dB	15.1 dB	1.2		22½	572	384, 385	\$390		
G347A			15.2 dB			19	483	384, 385	\$310		
S375A	Attenuator, flap	± 1 dB at < 10 dB	0 to 20 dB	1.15	2	14½	359	374	\$250		
G375A		± 2 dB at > 10 dB				13	330	374	\$200		
S382B*	Attenuator, precision variable	± 1% or 0.1 dB to 50 dB	0 to 60 dB	1.2 below 3 GHz; 1.15 above 3 GHz	10	25¼	641	374	\$650		
S382C*		± 2% above 50 dB									\$700
G382A		± 2% of reading or 0.1 dB, whichever is greater				0 to 50 dB	1.15	15	31¾	803	374
S424A	Crystal detector	sensitivity: > 0.4 mV/μW	sensitivity: 0.4 mV/μW	1.35		2-7/16	62	273	\$175		
G424A						2-1/16	52	273	\$165		
S486A	Thermistor mount, compensated		0.001 to 10 mW	1.35		3	76	378-380	\$195		
G486A				1.5		4	102	378-380	\$180		
G532A	Frequency meter, direct reading	dial: ± 0.033% overall: ± 0.065%				6¼	159	530	\$400		
S752A	Directional couplers, multi-hole	mean: ± 0.4 dB variation: ± 0.5 dB	3 dB	1.1	2 (in aux. guide)	50¼	1276	276	\$500		
S752C			10 dB	1.05		48	1219				
S752D			20 dB	1.05		48	1219				
G752A			3 dB	1.1		34½	876	276	\$325		
G752C			10 dB	1.05		33	838				
G752D			20 dB	1.05		33	838				
G810B (809C) (444A)	Slotted section, waveguide (Carriage for 810B) (Detector probe for 809C)			1.01		10¼	260	260, 261	\$140 (\$200) (\$55)		
S870A	Tuner, slide screw	insertion loss: < 2 dB at 20:1 swr	corrects swr of 20			11	279	277	\$350		
G870A						8¼	210	277	\$275		
S910A	Termination, low power			1.04	2	10¼	260	278	\$90		
G910A						6¾	168	278	\$70		
S914A	Moving load	load reflection: < 0.5%	> ½ wavelength	1.01	2	31	787	278	\$150		
G914A						20½	521	278	\$120		
S920A	Adjustable short		> ½ wavelength			10-7/16	265	278	\$150		
G920A						7-13/16	199	278	\$125		
11540A	Waveguide stand							279	\$3		
11541A	S-band waveguide clamp							279	\$2.50		
11542A	G-band waveguide clamp							279	\$2.50		

\* Degree dial 0 to 90° in 0.1° increments (S382B), in 0.01° increments (S382C).

# WAVEGUIDE INSTRUMENTATION

Quality equipment for microwave measurements  
J-band, 5.30 to 8.20 GHz



## COAXIAL, WAVEGUIDE

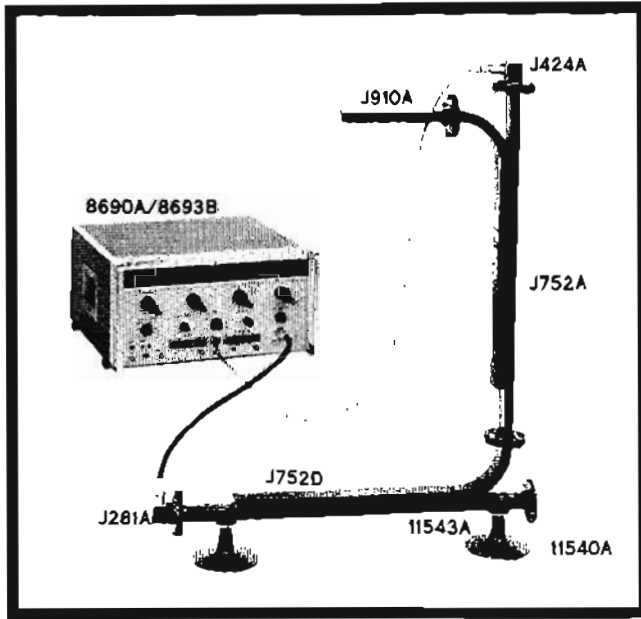

In the illustration, leveled output power from the sweep oscillator is obtained through use of the J752 Directional Couplers in the configuration shown. The J424A Crystal Detector, with its extremely flat frequency response, provides the error voltage to the ALC input of the sweep oscillator. The power delivered at the output port of the J752D Coupler is flat to better than 1/2 dB, and the high directivity of the coupler makes the leveling loop virtually immune to load swr.

### Complementary equipment

HP Instrument	Frequency Range (GHz)	Price
618C Signal Generator	3.8 to 7.6	\$2250*
620B Signal Generator	7 to 11	\$2250*
8690A Sweep Oscillator	—	\$1550
8693A RF Unit	4 to 8	\$1575
8693B RF Unit	4 to 8	\$1900
HO1-8693B RF Unit	3.7 to 8.3	\$2200
493A Microwave Amplifier	4 to 8	\$2600
8733A PIN Modulator	3.7 to 8.3	\$325
8733B PIN Modulator	3.7 to 8.3	\$550

\*Add \$20 for rack mount

### J-band equipment

HP Model	Description	Accuracy	Range	SWR (max.)	Power (watts)	Length		Page reference	Price
						(in)	(mm)		
J281A	Adapter, waveguide-to-coax			1.25 (1.3 from 5.3 to 5.5 GHz)		2	51	279	\$35
J347A	Noise source, waveguide	±0.5 dB	15.2 dB	1.2		19	483	384, 385	\$300
J375A	Attenuator, flap	±1 dB at < 10 dB ±2 dB at > 10 dB	0 to 20 dB	1.15	2	13	330	374	\$175
J382A	Attenuator, precision variable	±2% of reading or 0.1 dB whichever is greater	0 to 50 dB	1.15	10	25½	638	374	\$375
J424A	Crystal detector	response: ±0.2 dB	sensitivity > 0.4 mV/μW	1.35		1½	48	273	\$165
J485B	Detector mount (less detector)			with barretter 1.25 (5.85 to 8.2 GHz) 1.5 overall		8¼	210	258	\$120
J486A	Thermistor mount, compensated		0.001 to 10 mW	1.5		3¾	86	378-379	\$170
J487B	Thermistor mount, broadband		0.01 to 10 mW	1.5		1¾	45	381	\$90
J532A	Frequency meter, direct reading	dial: ±0.033% overall: ±0.065%				6¼	159	530	\$375
J752A J752C J752D	Directional couplers, multi-hole	mean: ±0.4 dB variation: ±0.5 dB (5.85 to 8.2 GHz)	3 dB 10 dB 20 dB	1.1 1.05 1.05	1 (in aux. guide)	26½ 25-9/16 25-9/16	673 649 649	276	\$220
J810B (809C) (444A)	Slotted section, waveguide (Carriage for 810B) (Detector probe for 809C)			1.01		10¼	260	260, 261	\$125 (\$200) (\$55)
J870A	Tuner, slide screw	insertion loss: < 2 dB at 20:1 swr	corrects swr of 20			7½	194	277	\$200
J885A	Waveguide phase shifter	lesser of 3° or 10%	-360° to +360°	1.35	10	25¼	638	277	\$550
J910A	Termination, low power			1.02	1	8¼	206	278	\$55
J914A	Moving load	load reflection: < 0.5%	> ½ wavelength	1.01	2	15½	394	278	\$100
J920A	Adjustable short		> ½ wavelength			6¼	159	278	\$100
11540A	Waveguide stand							279	\$3
11543A	Waveguide clamp							279	\$2.50



## WAVEGUIDE INSTRUMENTATION

Quality equipment for microwave measurements  
H-band, 7.05 to 10 GHz

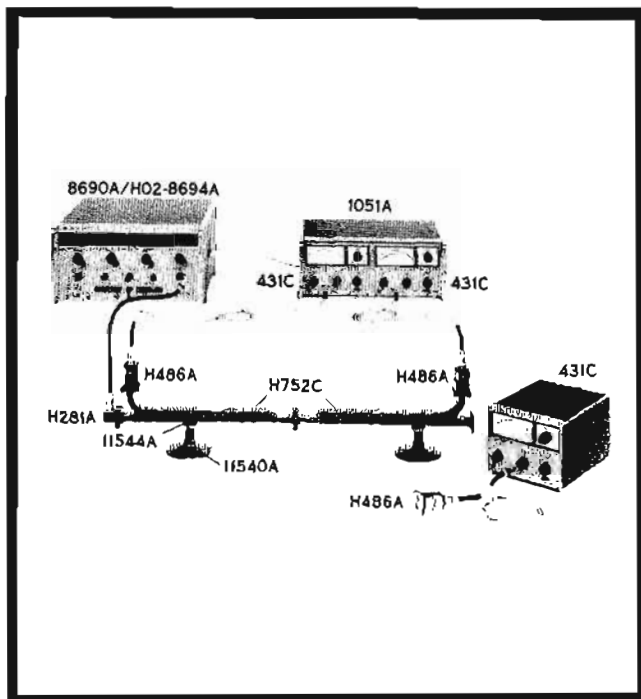

The figure illustrates a swept-frequency system employing power meter leveling, in which the system is arranged to provide leveled net forward power at the mainline output of the right-hand H752C Directional Coupler. Both the incident and reflected powers are monitored, with the recorder outputs of the two 431C Power Meters connected in such a manner that the resultant voltage fed back to the sweep oscillator is related to the power actually absorbed by the load. Typical applications for this type of leveling include measurement of thermistor mount efficiency and antenna radiation characteristics.

### Complementary equipment

HP Instrument	Frequency range (GHz)	Price
620B Signal Generator	7 to 11	\$2250*
8690A Sweep Oscillator	—	\$1550
HO2-8694A RF Unit	7 to 11	\$1600
HO2-8694B RF Unit	7 to 11	\$1950
495A Microwave Amplifier	7 to 12.4	\$2600
8734A PIN Modulator	7 to 12.4	\$350
8734B PIN Modulator	7 to 12.4	\$575

\*Add \$20 for rack mount

### H-band equipment

HP Model	Description	Accuracy	Range	SWR (max.)	Power (watts)	Length		Page reference	Price
						(in)	(mm)		
H281A	Adapter, waveguide-to-coax			1.25		1½	41	279	\$30
HX292B	Adapter, waveguide-to-waveguide		8.2 to 10 GHz	1.05		1½	38	279	\$40
H347A	Noise source, waveguide	±0.5 dB	15.7 dB	1.2		16	406	384, 385	\$275
H375A	Attenuator, flap	±1 dB at < 10 dB ±2 dB at > 10 dB	0 to 20 dB	1.15	2	8¼	210	374	\$150
H382A	Attenuator, precision variable	±2% of reading, or 0.1 dB, whichever is greater	0 to 50 dB	1.15	10	20	508	374	\$350
H424A	Crystal detector	response: ±0.2 dB	sensitivity > 0.4 mV/μW	1.35		1-9/16	40	273	\$155
H485B	Detector mount (less detector)			with barretter 1.25		6¾	162	258	\$100
H486A	Thermistor mount, compensated		0.001 to 10 mW	1.5		3¾	86	378-379	\$165
H487B	Thermistor mount, broadband		0.01 to 10 mW	1.5		1-5/16	33	381	\$80
H532A	Frequency meter, direct reading	dial: ±0.040% overall: ±0.075%				6¼	159	530	\$325
H752A H752C H752D	Directional couplers, multi-hole	mean: ±0.4 dB variation: ±0.5 dB	3 dB 10 dB 20 dB	1.1 1.05 1.05	1 (in aux. guide)	18¾ 17½ 17½	473 445 445	276	\$165
H810B (809C) (444A)	Slotted sections, waveguide (Carriage for 810B) (Detector probe for 809C)			1.01		10¾	260	260, 261	\$110 (\$200) (\$55)
H870A	Tuner, slide screw	insertion loss: < 2 dB at 20:1 swr	corrects swr of 20			6	152	277	\$170
H910A	Termination, low power			1.02	1	5-9/16	141	278	\$45
H914A	Moving load	load reflection: < 0.5%	> ½ wavelength	1.01	1	11½	267	278	\$80
H920A	Adjustable short		> ½ wavelength			4¾	124	278	\$85
I1540A	Waveguide stand							279	\$3
I1544A	Waveguide clamp							279	\$2.50

# WAVEGUIDE INSTRUMENTATION

Quality equipment for microwave measurements  
X-band, 8.2 to 12.4 GHz



## COAXIAL, WAVEGUIDE

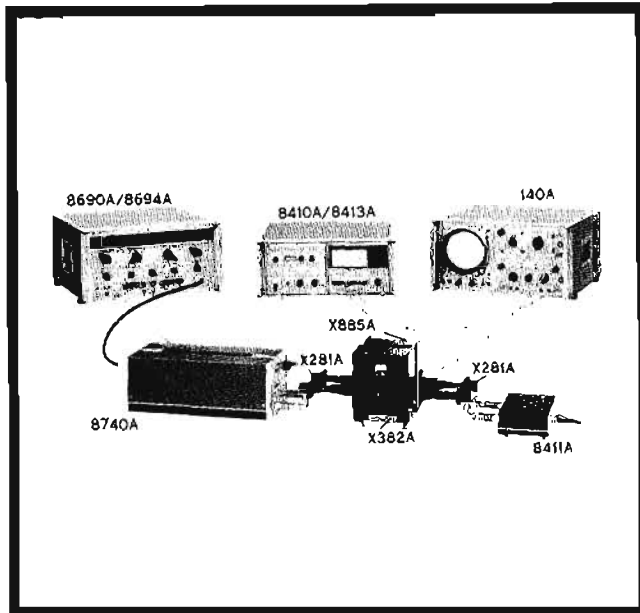

The variation of phase shift with attenuation of the X382A Precision Variable Attenuator is measured in this setup. The new HP 8410A Network Analyzer permits this measurement to be made quickly and easily on a swept-frequency basis.

### Complementary equipment

HP Instrument	Frequency range (GHz)	Price
620B Signal Generator	7 to 11	\$2250*
626A Signal Generator	10 to 15.5	\$2250*
8690A Sweep Oscillator	—	\$1550
8694A RF Unit	8 to 12.4	\$1575
8694B RF Unit	8 to 12.4	\$1925
495A Microwave Amplifier	7 to 12.4	\$2600
8734A PIN Modulator	7 to 12.4	\$ 350
8734B PIN Modulator	7 to 12.4	\$ 575

\*Add \$20 for rack mount

### X-band equipment

HP Model	Description	Accuracy	Range	SWR (max.)	Power (watts)	Length		Page Reference	Price
						(in)	(mm)		
X281A	Adapter, waveguide-to-coax			1.25		1½	35	279	\$25
X281B	Adapter, waveguide-to-coax			1.25		1½	35	279	\$60
HX292B	Adapter, waveguide-to-waveguide		8.2 to 10 GHz	1.05		1½	38	279	\$40
MX292B	Adapter, waveguide-to-waveguide		10 to 12.4 GHz	1.05		2½	60	279	\$50
X347A	Noise source, waveguide	±0.4 dB	15.7 dB	1.2		1¼	375	384	\$225
X362A	Low-pass filter	insertion loss, passband: <1 dB stopband: >40 dB	passband: 8.2 to 12.4 GHz stopband: 16 to 37.5 GHz	passband 1.5		5-11/32	136	272	\$325
X375A	Attenuator, flap	=1 dB at <10 dB =2 dB at >10 dB	0 to 20 dB	1.15	2	7-3/16	183	374	\$110
X382A	Attenuator, precision variable	=2% of reading or 0.1 dB whichever is greater	0 to 50 dB	1.15	10	15½	397	374	\$275
X424A	Crystal detector	response: ±0.3 dB	sensitivity >0.4 mV/√W	1.35		1½	35	273	\$135
X485B	Detector mount (less detector)			with barretter 1.25		6-7/16	164	258	\$75
X486A	Thermistor mount, compensated		0.001 to 10 mW	1.5		2½	54	378	\$145
X487B	Thermistor mount, broadband		0.01 to 10 mW	1.5		1-3/16	30	381	\$75
X532B	Frequency meter, direct reading	dial: =0.05% overall: =0.06%				4½	114	530	\$200
X752A	Directional couplers, multi-hole	mean: =0.4 dB variation: =0.5 dB	3 dB	1.1	1 (In aux. guide)	16-11/16	424	276	\$125
X752C			10 dB	1.05		15-11/16	399		
X752D			20 dB	1.05		15-11/16	399		
X810B (809C) (444A)	Slotted section, waveguide (Carriage for 810B) (Detector probe for 809C)			1.01		10½	260	260, 261	\$90 (\$200) (\$55)
X870A	Tuner, slide screw	insertion loss: <2 dB at 20.1 swr	corrects swr of 20			5½	140	277	\$150
X885A	Waveguide phase shifter	<2° at 8.2 to 10 GHz or 10% <3° at 10 to 12.4 GHz or 10%	-360° to +360°	1.35	10	15½	397	277	\$425
X910B	Termination, low power			1.015	1	6½	168	278	\$35
X913A	Termination, high power			1.05	500	9½	241	279	\$125
X914B	Moving load	load reflection: <0.5%	>½ wavelength	1.005	1	10½	257	278	\$60
X923A	Adjustable short		>½ wavelength			4½	124	278	\$75
X930A	Waveguide shorting switch	insertion loss "Open": <0.05 dB		"Open": 1.02 "Shorted": >125		3-11/16	94	279	\$160
8735A	PIN modulator		35 dB	1.7 (min. atten.) 2 (max. atten.)	1	6½	171	370, 371	\$350
8735B	PIN modulator		80 dB	2.0 (min. atten.) 2.2 (max. atten.)	1	10½	267	370, 371	\$575
11504A	Flexible waveguide					12	305		\$35
11540A	Waveguide stand							279	\$3
11545A	Waveguide clamp							279	\$2.50



# COAXIAL, WAVEGUIDE



## WAVEGUIDE INSTRUMENTATION

Quality equipment for microwave measurements  
P-band, 12.4 to 18 GHz

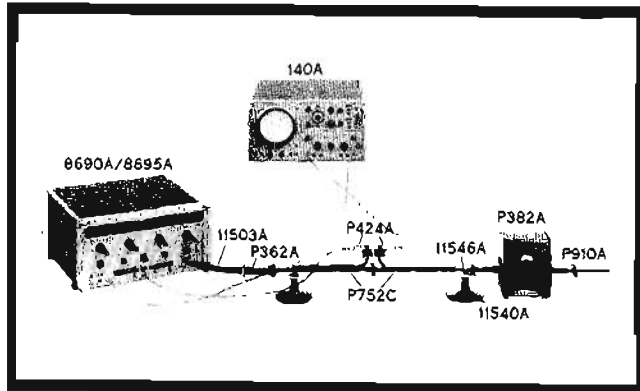

The conventional swept-frequency reflectometer in the illustration is being used to examine the reflection characteristics of the P382A Attenuator. The flat frequency response and excellent square law characteristics of the P424A Crystal Detectors provide accurate measurement results, with the added advantage that reflection characteristics can be displayed directly on the oscilloscope crt.

### Complementary equipment

HP Instrument	Frequency range (GHz)	Price
626A Signal Generator	10 to 15.5	\$3400*
628A Signal Generator	15 to 21	\$3400*
8690A Sweep Oscillator	—	\$1550
8695A RF Unit	12.4 to 18	\$1700

\*Add \$20 for rack mount

### P-band equipment

HP Model	Description	Accuracy	Range	SWR (max.)	Power (watts)	Length		Page reference	Price
						(in)	(mm)		
P281B			12.4 to 18 GHz	1.25		1 3/8	35	279	\$65
MP292B	Adapter, waveguide-to-waveguide		12.4 to 15 GHz	1.05		2 3/8	60	279	\$40
NP292A	Adapter, waveguide-to-waveguide		15 to 18 GHz	1.05		2 3/8	60	279	\$40
P347A	Noise source, waveguide	$\pm 0.5$ dB	16 dB			1 1/4	375	384, 385	\$275
P362A	Low-pass filter	insertion loss, pass-band: $< 1$ dB stopband: $> 40$ dB	pass: 12.4 to 18 GHz stop: 23 to 54 GHz	passband 1.5		3-11/16	94	272	\$350
P375A	Attenuator, flap	$\pm 1$ dB at $< 10$ dB $\pm 2$ dB at $> 10$ dB	0 to 20 dB	1.15	1	7/8	184	374	\$135
P382A	Attenuator, precision variable	$\pm 2\%$ of reading or 0.1 dB, whichever is greater	0 to 50 dB	1.15	5	1 1/2	318	374	\$300
P424A	Crystal detector	response: $\pm 0.5$ dB	sensitivity $> 0.3$ mV/ $\mu$ W	1.5		15/16	24	273	\$175
P486A	Thermistor mount, compensated		0.001 to 10 mW	1.5		2 1/2	64	378-379	\$195
P487B	Thermistor mount, broadband		0.01 to 10 mW	1.5		1 3/16	21	381	\$110
P532A	Frequency meter, direct reading	dial: $\pm 0.068\%$ overall: $\pm 0.1\%$				4 1/2	114	530	\$275
P752A P752C P752D	Directional couplers, multi-hole	mean: $\pm 0.4$ dB variation: $\pm 0.5$ dB	3 dB 10 dB 20 dB	1.1 1.05 1.05	1 (in aux. guide)	1 3/8 1 1/4 1 1/4	349 311 311	276	\$150
P810B (809C) (444A)	Slotted section, waveguide (Carriage for 810B) (Detector probe for 809C)			1.01		10 1/4	260	260, 261	\$110 (\$200) (\$55)
P870A	Tuner, slide screw	insertion loss: $< 2$ dB at 20:1 swr	corrects swr of 20			5	127	277	\$160
P885A	Waveguide phase shifter	lesser of 4° or 10%	-360° to +360°	1.35	5	12-5/16	312	277	\$600
P910A	Termination, low power			1.02	1	4 3/8	111	278	\$40
P914A	Moving load	load reflection: $< 0.5\%$	$> 1/2$ wavelength	1.02	0.5	9 3/4	248	278	\$75
P920B	Adjustable short		$> 1/2$ wavelength			5 1/4	146	278	\$125
P932A	Harmonic mixer				0.1			—	\$250
11503A	Flexible waveguide, P-band					12	305	—	\$48
11540A	Waveguide stand							279	\$3
11546A	Waveguide clamp							279	\$2.50

# WAVEGUIDE INSTRUMENTATION

Quality equipment for microwave measurements  
K-band, 18 to 26.5 GHz, and R-band, 26.4 to 40 GHz



## COAXIAL, WAVEGUIDE

Illustrated here is a typical fixed-frequency measurement system for K-band. The K870A Slide Screw Tuner tunes the K486A Thermistor Mount to unity swr for improved power measurement accuracy.

### Complementary Equipment

HP Instrument	Frequency Range (GHz)	Price
626A Signal Generator and 938A Frequency Doubler Set	20 to 26.5	\$3400*
626A Signal Generator and 940A Frequency Doubler Set	26.5 to 31	\$1700
628A Signal Generator and 940A Frequency Doubler Set	30 to 40	\$3400*
628A Signal Generator and 940A Frequency Doubler Set	30 to 40	\$1700
8690A Sweep Oscillator	—	\$1550
8696A RF Unit	18 to 26.5	\$2500
8697A RF Unit	26.5 to 40	\$4300

\*Add \$20 for rack mount

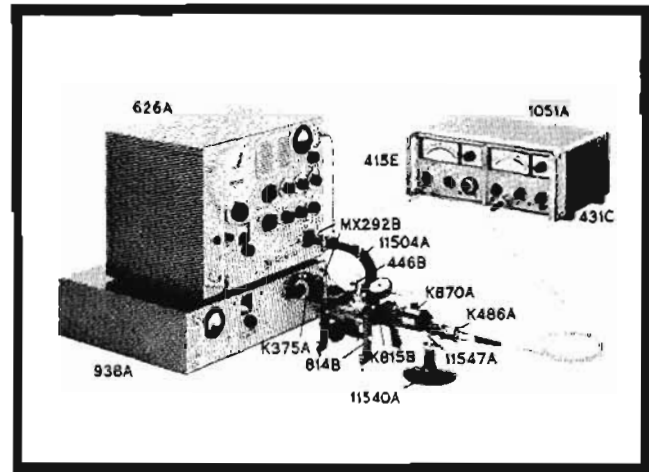

### K- and R-band equipment

HP Model*	Description	Accuracy	Range	SWR (max)	Power (watts)	Length		Page Reference	Price
						(in)	(mm)		
K362A	Low-pass filter	insertion loss, pass-band: <1 dB stopband: >40 dB	pass: 18 to 26.5 GHz stop: 31 to 80 GHz	passband 1.5		2½	64	272	\$385
R362A		insertion loss, pass-band: <2 dB stopband: >35 dB	pass: 26.5 to 40 GHz stop: 47 to 120 GHz	passband 1.8		1¾	42		
K375A	Attenuator, flap	±1 dB at <10 dB ±2 dB at >10 dB	0 to 20 dB	1.15	0.5	4½	114	374	\$200
R375A							4¾	111	374
K382A	Attenuator, precision variable	±2% of reading or 0.1 dB, whichever ever is greater	0 to 50 dB	1.15	2	7⅞	194	374	\$475
R382A					1	6⅞	162	374	\$500
K422A	Crystal detector	freq. resp: ±2 dB sens: 0.3 mV dc/ μW CW		2.5		2	51	273	\$230
R422A				3					\$540 (matched pair)
K486A	Thermistor mount, compensated		0.001 to 10 mW	2		3	76	378-379	\$300
R486A									\$375
K532A	Frequency meter, direct reading	dial: ±0.077% overall: ±0.11%				4½	114	530	\$350
R532A		dial: ±0.083% overall: ±0.12%							\$400
K752A	Directional couplers, multi-hole	mean: ±0.7 dB variation: ±0.5 dB (±0.6 dB, R752D)	3 dB	1.1	0.5 (in aux. guide)	10%	270	276	\$200
K752C			10 dB	1.05		9-15/16	252		
K752D			20 dB	1.05		9-15/16	252		
R752A			3 dB	1.1		11%	295		
R752C			10 dB	1.05		8¾	219		
R752D			20 dB	1.05		8¾	222		
K815B	Slotted section, waveguide			1.01		7-9/16	192	260, 261	\$350
R815B									\$400
(814B) (446B)	(Carriage for 815B) (Detector probe for 814B)							260, 261	\$275 \$160
K870A	Tuner, slide screw	insertion loss: <3 dB at 20:1 swr	corrects swr of 20			4½	108	277	\$300
R870A									\$325
K914B	Moving load	load reflection: <0.5%	>½ wavelength	1.01	0.5	6½	156	278	\$275
R914B									
K920B	Adjustable short		>½ wavelength			5½	140	278	\$155
R920B									4½
11540A	Waveguide stand							279	\$3
11547A	K-band Waveguide clamp							279	\$2.50
11548A	R-band Waveguide clamp							279	\$2.50

\* Circular flange adapters 11515A (UG-425/U) for K-band, \$35 each; 11516A (UG-381/U) for R-band, \$40 each.



**LOW-PASS, BANDPASS FILTERS**

Effective elimination of undesirable signals

Models 360A-D, 362A, 8430

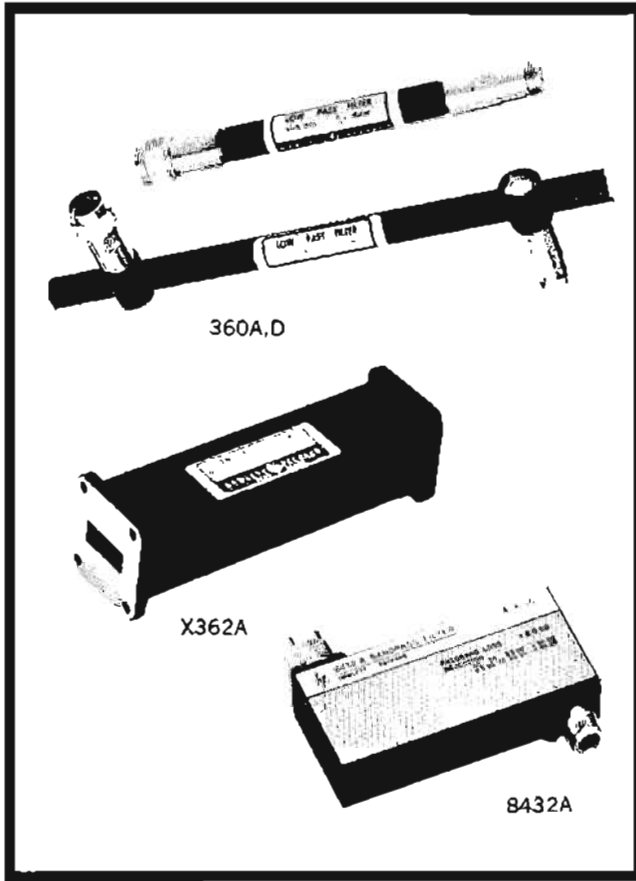

These Hewlett-Packard low-pass and bandpass filters facilitate microwave measurements by eliminating undesirable signals (such as harmonics) from the measurement system. Suppression of such signals is particularly important in applications such as slotted-line measurements, where harmonics generated by the signal source could otherwise impair measurement accuracy. These filters also can be used as preselectors for the HP 851B/8551B Spectrum Analyzer. As such, they permit the maximum utilization of the analyzer's broad spectrum-width capability while assuring virtually spurious-free displays.

**Specifications, 360 Series**

HP Model	360A	360B	360C	360D
Cut-off frequency	700 MHz	1200 MHz	2200 MHz	4100 MHz
Insertion loss	≤1 dB below 0.9 times cut-off frequency			
Rejection	≥50 dB at 1.25 times cut-off frequency			
Impedance	50 ohms through pass band; should be matched for optimum performance			
SWR	< 1.6 to within 100 MHz of cut-off	< 1.6 to within 200 MHz of cut-off	< 1.6 to within 300 MHz of cut-off	< 1.6 to within 300 MHz of cut-off
Connectors	Type N, one male, one female			
Overall length	10 7/8 (276 mm)	7-7/32 (183 mm)	10-25/32 (274 mm)	7 3/4 (187 mm)
Center line to male end	2 1/4 (54 mm)	2 1/4 (54 mm)	—	—
Center line to female end	2 1/4 (57 mm)	2 1/4 (57 mm)	—	—
Shipping weight	2 (0.9 lbs)	2 (0.9 lbs)	2 (0.9 lbs)	1 (0.45 lbs)
Price	\$75	\$70	\$65	\$60

**Specifications, 362A Series**

HP Model	X362A	M362A	P362A	K362A*	R362A*
Passband (GHz)	8.2-12.4	10.0-15.5	12.4-18.0	18.0-26.5	26.5-40.0
Stop band (GHz)	16-37.5	19-47	23-54	31-80	47-120
Insertion loss	less than 1 dB	less than 1 dB	less than 1 dB	less than 1 dB	less than 2 dB
Stopband rejection	at least 40 dB	at least 40 dB	at least 40 dB	at least 40 dB	at least 35 dB
SWR	1.5	1.5	1.5	1.5	1.8
Waveguide size, in. (EIA)	1 x 0.5 (WR 90)	0.850 x 0.475 (WR 75)	0.702 x 0.391 (WR 62)	1/2 x 1/4 (WR 42)	0.360 x 0.220 (WR 28)
Length, in. (mm)	5-11/32(136)	4-15/32(114)	3-11/16(94)	2 1/2(64)	1-21/32(42)
Shipping weight, lbs. (kg)	2(0.9)	2(0.9)	1(0.45)	1/2(0.23)	1/2(0.23)
Price	\$325	\$350	\$350	\$385	\$385

\* Circular flange adapters: K-band (UG-425/U), HP 11515A, \$35 each; R-band (UG-381/U), HP 11516A, \$40 each.

**Specifications, 8430 Series**

HP Model	Passband frequency (GHz)	Max. passband insertion loss	Rejection band attenuation				Dimensions		Shipping weight		Price
			Below passband		Above passband		(in.)	(mm)	(lb)	(kg)	
			Frequency (GHz)	Attenuation	Frequency (GHz)	Attenuation					
8430A	1 to 2	2 dB	≤0.8	≥50 dB	2.2 to 20	≥45 dB	5 1/2 x 4 1/4 x 1	140 x 121 x 25	3	1.4	\$210
8431A	2 to 4	2 dB	≤1.6	≥50 dB	4.4 to 20	≥45 dB	5 1/2 x 3 x 1	140 x 76 x 25	2	0.9	\$210
8432A	4 to 6	2 dB	≤3.5	≥50 dB	6.5 to 20	≥45 dB	4 1/2 x 2 x 1	114 x 51 x 25	2	0.9	\$275
8433A	6 to 8	2 dB	≤5.5	≥50 dB	8.5 to 20	≥45 dB	4 x 1 1/2 x 1	102 x 38 x 25	2	0.9	\$275
8434A	8 to 10	2 dB	≤7.5	≥50 dB	10.5 to 17	≥45 dB	4 3/8 x 1 x 1	118 x 25 x 25	2	0.9	\$275
8435A	4 to 8	2 dB	≤3.2	≥50 dB	8.8 to 20	≥45 dB	3 3/8 x 1 1/4 x 1	92 x 45 x 25	2	0.9	\$210
8436A	8 to 12.4	2 dB	≤6.9	≥50 dB	13.5 to 17	≥45 dB	2 1/2 x 1 x 1	73 x 25 x 25	1	0.45	\$210

Connectors: Type N, one male, one female.

# CRYSTAL DETECTORS

Flat response, high sensitivity, low swr  
Models 8470A, 423A, 424A, 420A,B, 422A



## COAXIAL, WAVEGUIDE

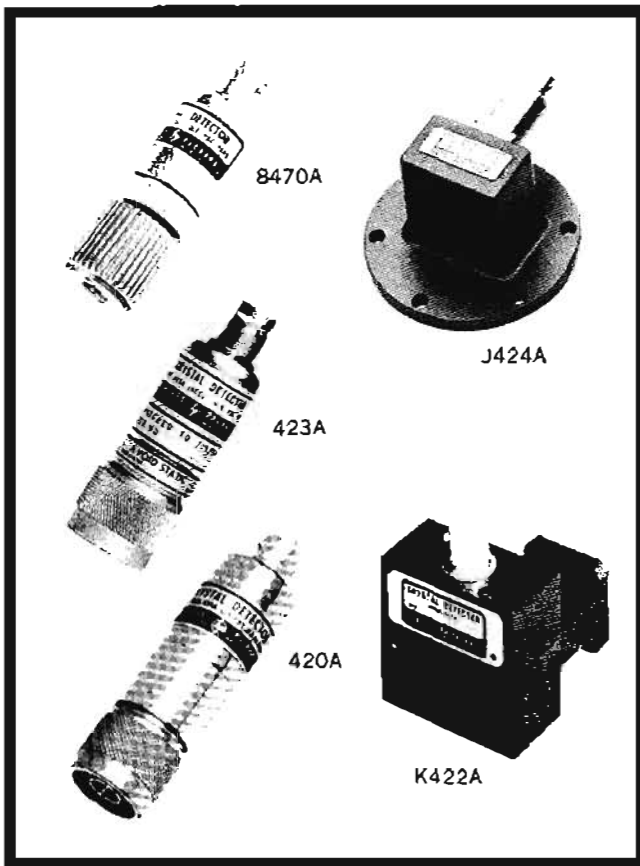

The HP 8470A extends the frequency range of coaxial crystal detectors to 18 GHz. Like the 423A and 424A Crystal Detectors, the 8470A combines extremely flat frequency response with high sensitivity and very low swr. Such performance is due to a crystal diode package developed by Hewlett-Packard, in which a superior diode is incorporated in a unique sealed capsule to provide best microwave characteristics. This approach also facilitates diode replacement, which can be made easily in the field. The flat frequency response and low swr of these detectors make them extremely useful as the detecting element in closed-loop leveling systems.

### Matched pairs

For applications in which both frequency response and square law characteristics are important, matched pairs of these detectors can be supplied with video loads for optimum square-law conformance. The low output capacitance of these detectors makes them ideal for detecting fast rf pulses; working into a low-capacitance 50-ohm load, their rise time is in the nanosecond region. Good pulse response permits their use in peak power measurement where the detected pulse is compared against a known CW level on a sensitive dc-coupled oscilloscope such as HP 140A or 175A.

The 422A Crystal Detectors are convenient waveguide detectors which cover K- and R-bands. They have a dynamic range of 40 dB or more, making them suitable for reflectometer as well as general-purpose applications.

The 420A is a low-cost crystal detector which covers the coaxial range from 10 MHz to 12.4 GHz, making it ideal for general-purpose video detection. The 420B is essentially the same unit as the 420A with the addition of a selected video load for optimum square-law characteristics in the 1 to 4 GHz range. Price: HP 420A, \$50; HP 420B, \$75.

			Low-level		Matched	Square	Length		Shipping weight			
423A	0.01-12.4	$\approx 0.2$ /octave to 8 GHz; $\approx 0.5$ overall	>0.4	1.2 to 4.5 GHz; 1.35 to 7 GHz; 1.5 to 12.4 GHz	Type N male							
8470A	0.01-18	$\approx 0.2$ /octave to 8 GHz; $\approx 0.5$ to 12.4 GHz; $\approx 1$ overall	>0.4	1.2 to 4.5 GHz; 1.35 to 7 GHz; 1.5 to 12.4 GHz; 1.7 to 18 GHz	APC-7	yes <sup>2</sup>	yes <sup>3</sup>	2 1/2	63	1	0.5	HP 8470A, \$150
S424A	2.60-3.95	$\approx 0.2$	>0.4	1.35	Waveguide cover flange	yes <sup>4</sup>	yes <sup>3</sup>	2-7/16	62	2	0.9	HP S424A, \$175
G424A	3.95-5.85	$\approx 0.2$	>0.4	1.35		yes <sup>4</sup>	yes <sup>3</sup>	2-1/16	52	2	0.9	HP G424A, \$165
J424A	5.30-8.20	$\approx 0.2$	>0.4	1.35		yes <sup>4</sup>	yes <sup>3</sup>	1-7/8	48	1	0.5	HP J424A, \$165
H424A	7.05-10.0	$\approx 0.2$	>0.4	1.35		yes <sup>4</sup>	yes <sup>3</sup>	1-9/16	40	1	0.5	HP H424A, \$155
X424A	8.20-12.4	$\approx 0.3$	>0.4	1.35		yes <sup>4</sup>	yes <sup>3</sup>	1-3/8	35	1	0.5	HP X424A, \$135
M424A	10.0-15.0	$\approx 0.5$	>0.3	1.5		yes <sup>4</sup>	yes <sup>3</sup>	1	25	1	0.5	HP M424A, \$250
P424A	12.4-18.0	$\approx 0.5$	>0.3	1.5		yes <sup>4</sup>	yes <sup>3</sup>	15/16	24	1	0.5	HP P424A, \$175
K422A6	18.0-26.5	$\approx 2$	$\approx 0.3$	2.5		yes <sup>5</sup>	yes <sup>3</sup>	2	51	1	0.5	HP K422A, \$230
R422A6	26.5-40.0	$\approx 2$	$\approx 0.3$	3		yes <sup>5</sup>	yes <sup>3</sup>	2	51	1	0.5	HP R422A, \$230

For all models  
Maximum input: 100 mW peak or average.  
Detector element: supplied.

Output polarity: negative (positive output available with 423A, 8470A, 424A; specify Option 03.; no additional charge).  
Output connector: BNC female.

<sup>1</sup>As read on a 416 Ratio Meter or 415 SWR Meter calibrated for square law detectors.  
<sup>2</sup>Frequency response characteristics (excluding basic sensitivity) track within  $\pm 0.2$  dB per octave from 10 MHz to 8 GHz,  $\pm 0.3$  dB from 8 to 12.4 GHz, and (8470A only)  $\pm 0.6$  dB from 12.4 to 18 GHz; specify Option 01.; add \$40 per pair.  
<sup>3</sup> $\pm 0.5$  dB variation from square law up to 50 mV peak output into  $>75$  k $\Omega$ ; sensitivity typically  $>0.1$  mV/ $\mu$ W; specify Option 02.; add \$20.  
<sup>4</sup>Frequency response characteristics (excluding basic sensitivity) track within  $\pm 0.2$  dB for S-, G-, J- and H-band units,  $\pm 0.3$  dB for X-band units, and  $\pm 0.5$  dB for M- and P-band units; specify Option 01.; add \$40 per pair.  
<sup>5</sup>Matched pair of units fitted with square-law loads. Frequency response characteristics (excluding basic sensitivity) track within  $\pm 1$  dB for power levels less than approx. 0.05 mW; specify Option 01.; add \$80 per pair.  
<sup>6</sup>Circular flange adapters: 11515A (UG-425/U) for K-band, \$35 each; 11516A (UG-381/U) for R-band, \$40 each.



## DETECTORS, COUPLERS

High directivity for increased accuracy  
770, 780, 790 Series

### 778D Dual Directional Coupler

HP 778D is a new concept in coaxial couplers. Designed with an exponential coupling array, this 20-dB coupler has a frequency range of 100 MHz to 2 GHz. Directivity is 40 dB below 1 GHz, 34 dB above, making the 778D ideal for broadband reflectometers. Swept-frequency reflectometers save appreciable engineering and production time in the design and testing of broadband apparatus (such as antennas, transceivers, etc.), while insuring that all portions of the frequency range are examined.

### 774D-777D Dual Directional Couplers

The economical HP 774D - 777D Couplers cover frequency spreads of more than two-to-one, each centered on one of the important vhf/uhf bands. With high directivity, these couplers are also excellent for reflectometer applications. In addition, these units can handle fairly high power and have low insertion loss, so they can be permanently installed in coaxial lines for monitoring power, system flatness, etc.

### 780 Directional Detectors

The HP 780 Directional Detectors are directional couplers with built-in crystal detectors. In each case the coupler itself has extremely flat frequency response and good directivity, while the detector also has very good frequency response plus high sensitivity. The configuration of the directional detector reduces the number of ambiguities over the standard system of separate directional coupler and detector and makes possible tighter correlation between main-arm power and detected signal.

The directional detector is well suited for closed-loop

leveling applications, particularly with sweep oscillators such as the HP 8690A. Leveled power can be applied to a load regardless of the characteristics of cables, connectors, etc., between the rf source and directional detector. The 786D through 789C are coaxial devices; X781A has a coaxial input and X-band waveguide output for working into WR90 waveguide systems. All have good equivalent source match.

### 790 Directional Couplers

The 790 Directional Couplers are ultra-flat, high directivity couplers which are ideal for power-monitoring applications in coaxial systems. Output coupling (ratio of output power from main and auxiliary arms) is specified, rather than coupling factor. Thus, no correction factor is required to account for insertion and coupling losses in the main arm. With a power meter such as the HP 431C connected to the auxiliary arm, a calibrated, absolute power level can be conveniently established at any point in a system, and the output of the 431C Power Meter can be used as a leveling signal for sweep oscillators.

### Specifications, 778D

Frequency range: 100 MHz to 2 GHz.  
Minimum directivity: 40 dB to 1 GHz, 34 dB to 2 GHz.  
Coupling attenuation (each auxiliary arm): 20 dB.  
Auxiliary arm tracking:  $\pm 0.3$  dB to 1 GHz,  $\pm 0.5$  dB to 2 GHz.  
Max. primary and secondary line swr (50 $\Omega$  terminations): 1.1.  
Power-handling capacity: 50 W average, 10 kW peak.  
Primary line connectors: type N, one male, one female.  
Auxiliary arm connectors: type N female.  
Length: 16 $\frac{3}{4}$  in. (426 mm).  
Shipping weight: 5 lb (2.3 kg).  
Price: Model 778D, \$450.  
Option 11. Furnished with APC-7 connector in lieu of primary line type N, add \$25.

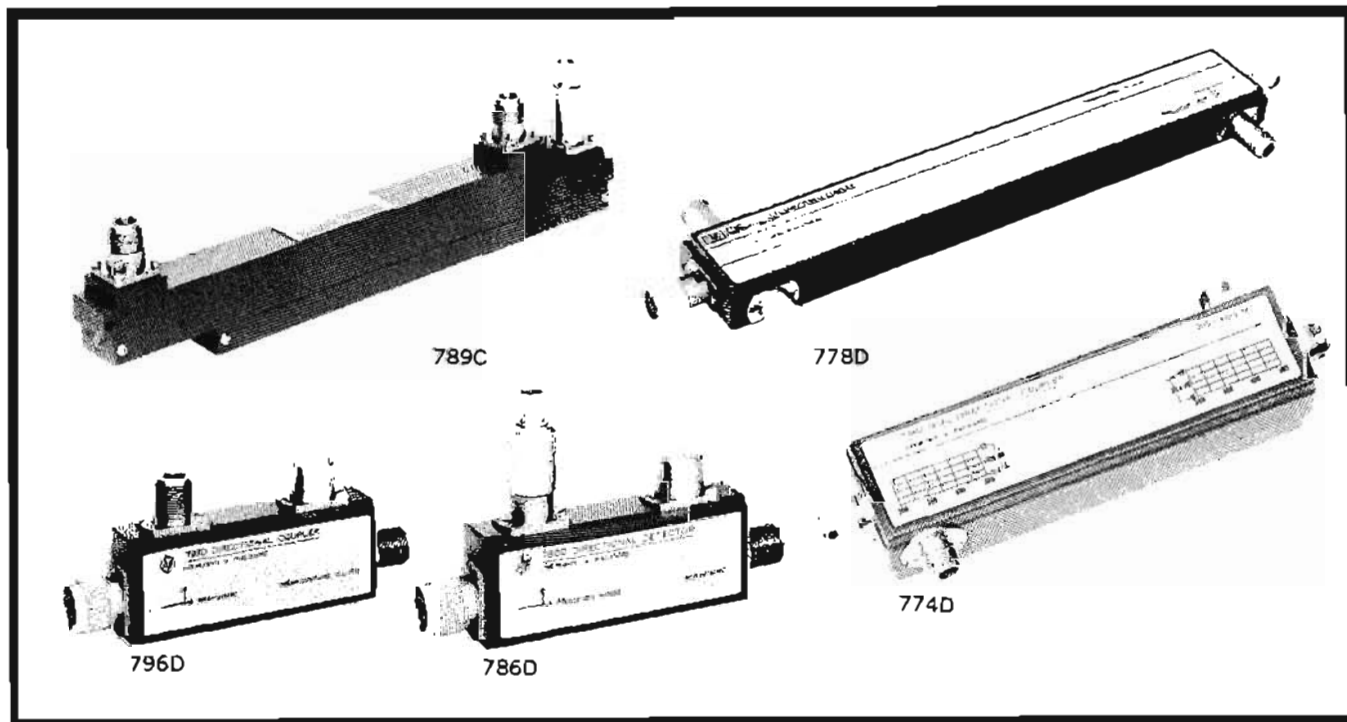

## Specifications, 774D — 777D

HP Model	774D	776D	776D	777D
Frequency range	215 to 450 MHz	450 to 940 MHz	940 to 1900 MHz	1900 to 4000 MHz
Minimum directivity <sup>1</sup>	40 dB	40 dB	40 dB	30 dB
Coupling attenuation (each auxiliary arm)	20 dB	20 dB	20 dB	20 dB
Accuracy of coupling (each auxiliary arm)	mean coupling level within 0.5 dB of specified values			
Max. coupling variation (50-ohm terminations)	±1 dB	±1 dB	±1 dB	±0.4 dB
Auxiliary arm tracking <sup>2</sup>	—	—	≤0.3 dB	≤0.5 dB
Max. primary line swr <sup>1</sup> (50-ohm terminations)	1.15	1.15	1.15	1.2
Max. auxiliary arm swr (50-ohm terminations)	1.2	1.2	1.2	1.25
Power-handling capacity	50 watts avg. 10 kW peak	50 watts avg. 10 kW peak	50 watts avg. 10 kW peak	50 watts avg. 10 kW peak
Primary line insertion loss	approx. 0.15 dB	approx. 0.2 dB	approx. 0.25 dB	approx. 0.6 dB
Primary line connectors	Type N, one male, one female			
Auxiliary arm connectors	Type N, female			
Accessories available	11511A Type N Female Shorting Jack, \$4; 11512A Type N Male Shorting Plug, \$4.50			
Length	9-1/16" (230 mm)	9-1/16" (230 mm)	6-5/16" (161 mm)	8-7/8" (225 mm)
Shipping weight	4 lbs (1.8 kg)	4 lbs (1.8 kg)	3 lbs (1.4 kg)	3 lbs (1.4 kg)
Price	\$225	\$225	\$225	\$275

<sup>1</sup>Measured with HP 906A Sliding Termination or K01-770D Line Length Set.

<sup>2</sup>Maximum change in the coupling curve of one auxiliary arm relative to the other.

## Specifications, 780 Series

HP Model	Frequency range (GHz)	Freq. resp. (dB) <sup>1,2</sup>	Low-level sens. (μV/μW)	Directivity (dB) <sup>1</sup>	Equiv. source match <sup>1,3</sup>	Max. swr	Max. input (W, peak or avg.)	Insertion loss (dB) <sup>4</sup>	Length		Shipping weight		Price
									(in)	(mm)	(lbs)	(kg)	
786D	0.96 to 2.11	±0.2	>4	30	1.13	1.15 <sup>1</sup>	10	0.25	6	152	2	0.9	\$300
787D	1.9 to 4.1	±0.2	>4	26	1.16	1.15 <sup>1</sup>	10	0.35	4 7/8	124	2	0.9	\$300
788C	3.7 to 8.3	±0.3	>40	20	1.25	1.20	1	0.6	4 7/8	124	2	0.9	\$325
789C	8.0 to 12.4	±0.5	>20	17	1.25	1.40	1	0.7	11 5/8	295	2	0.9	\$350
X781A	8.0 to 12.4	±0.5	>20	17	1.07	1.25 <sup>1</sup>	1	0.7	15 3/4	400	2	0.9	\$350

<sup>1</sup>Swept-frequency tested.

<sup>2</sup>As read on a 416 Ratio Meter or 415 SWR Meter calibrated for square-law detectors.

<sup>3</sup>The apparent swr at the output of an rf generating system, such as the output of a directional detector when it is used in a closed-loop leveling system.

<sup>4</sup>Includes loss due to coupling.

## For all models

**Detector output impedance:** 15 kΩ max. shunted by approx. 10 pF.

**Detector element:** supplied.

**Noise:** <200 μV peak to peak with CW power applied to produce 100 mV output.

**Detector output polarity:** negative.

**Detector output connector:** BNC female.

**RF connectors:** Type N, one male (input), one female (789C: both female; X781A: input, Type N female;

output, precision cover flange, fits 1" x 1/2" waveguide, EIA WR90).

## Options

- Furnished with load resistor for optimum square law characteristics at 24°C (75°F), <±0.5 dB variation from square law from low level up to 50 mV peak output (working into external load >75 kΩ); sensitivity typically one-fourth of unloaded sensitivity; add \$20.
- Positive polarity detector output; no additional charge.

## Specifications, 790 Series

HP Model	Frequency range (GHz)	Mean output coupling (dB) <sup>1</sup>	Output coupling variation (dB) <sup>2</sup>	Directivity (dB) <sup>2</sup>	Equiv. source match <sup>2,3</sup>	Max. primary line swr	Max. aux. arm swr	Max. input (W)	Insertion loss (dB) <sup>4</sup>	Length		Shipping weight		Price
										(in)	(mm)	(lbs)	(kg)	
796D	0.96 to 2.11	20 ±0.5	±0.2	30	1.13	1.15 <sup>2</sup>	1.20 <sup>2</sup>	50	0.25	6	152	2	0.9	\$200
797D	1.9 to 4.1	20 ±0.5	±0.2	26	1.16	1.15 <sup>2</sup>	1.25 <sup>2</sup>	50	0.35	4 7/8	124	2	0.9	\$200
798C	3.7 to 8.3	10 ±0.3	±0.3	20	1.25	1.20	1.20	10	0.6	4 7/8	124	2	0.9	\$225

For all models: rf connectors: primary line: type N, one male (input), one female; auxiliary arm: type N female.

<sup>1</sup>Difference in dB between power out of primary line and auxiliary arm.

<sup>2</sup>Swept-frequency tested.

<sup>3</sup>The apparent swr at the output port of a directional coupler when it is used in a closed-loop leveling system.

<sup>4</sup>Includes loss due to coupling.

## COAXIAL, WAVEGUIDE



## DIRECTIONAL COUPLERS

Easy-to-use, precision instruments

Model 752A,C,D

The HP 752 Directional Couplers are important tools in waveguide measurements. They can be used to monitor power, measure reflections, mix signals, or isolate signal sources or wavemeters.

Each coupler has an overall directivity of better than 40 dB (including reflection from built-in termination and flange) over its entire range. Performance characteristics are unaffected by humidity, temperature or time, thus making these units especially useful in microwave "standards" measurements. Coupling factors are 3, 10 and 20 dB; mean coupling accuracy is  $\pm 0.4$  dB ( $\pm 0.7$  dB for K- and R-bands); and coupling variation vs frequency is  $\pm 0.5$  dB ( $\pm 0.6$  dB for R752D).

Used together and connected back to back, two couplers are most useful with the HP 8690A Sweep Oscillator (see Signal Sources) in broadband reflection and swr measurements. One directional coupler samples power traveling toward the load, and the detected sample can be used to maintain a constant forward power. The output of the auxiliary arm of the second coupler, which samples power reflected from the load, is then a direct indication of reflection coefficient and swr. After detection, this signal can be viewed on an oscilloscope or permanently recorded on an x-y recorder. The HP 424A Series Crystal Detectors are ideal for use with the 752 couplers.

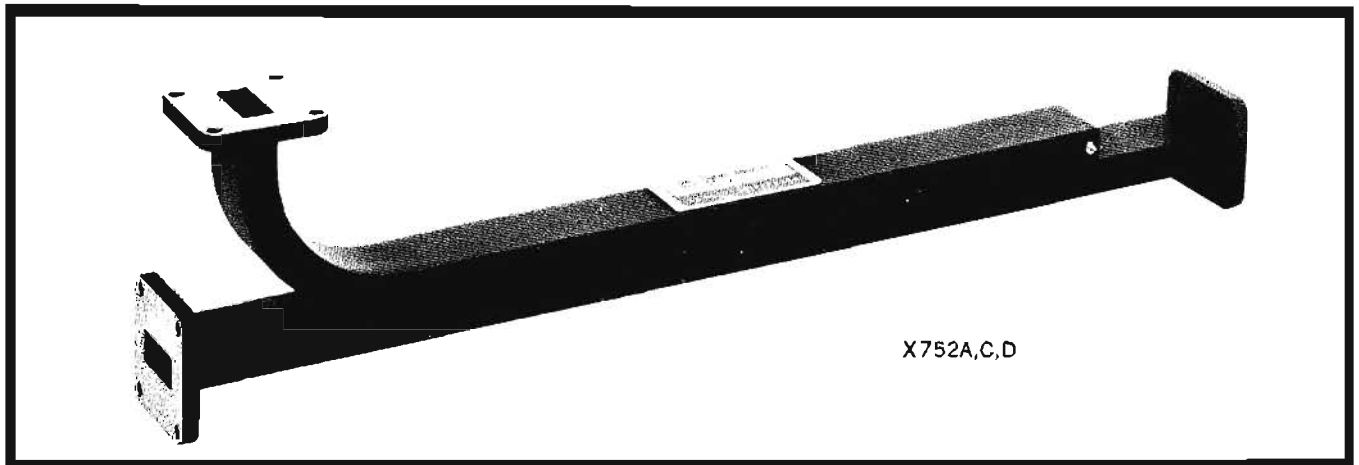

In the system described above, the variation in coupling with frequency of the two couplers tends to cancel. This cancellation effectively improves the leveling of the signal source and increases the accuracy of the measurement. For applications in which the actual variations in source

output must be minimized, matched pairs of couplers for the leveling loop are available on special order. The pair comprises a 3- and 10- or 20-dB coupler. The 3-dB coupler is connected to the auxiliary arm of the 10- or 20-dB coupler, reducing coupling variation to less than  $\pm 0.2$  dB.

### Specifications, 752 Series

Band <sup>1,2</sup> (prefix)	Frequency (GHz)	Flts waveguide size (in)	Mean coupling accuracy (dB) <sup>3,4</sup>	SWR <sup>5,6</sup> main guide		Average power aux. guide load (W)	Length (in)			Shipping weight		Price
				762A	762C,D		A	C	D	(lbs)	(kg)	
S	2.6-3.95	3 x 1½	$\pm 0.4$	1.1	1.05	2	50¼	48	48	38	17.1	\$500
G	3.95-5.85	2 x 1	$\pm 0.4$	1.1	1.05	2	34½	33	33	16	7.4	\$325
J*	5.85-8.2	1½ x ¾	$\pm 0.4$	1.1	1.05	1	26½	25-9/16	25-9/16	13	5.8	\$220
H	7.05-10	1¼ x ¾	$\pm 0.4$	1.1	1.05	1	18¾	17½	17½	4	1.8	\$165
X	8.2-12.4	1 x ½	$\pm 0.4$	1.1	1.05	1	16-11/16	15-11/16	15-11/16	3	1.4	\$125
P	12.4-18	.702 x .391	$\pm 0.4$	1.1	1.05	1	13¾	12¼	12¼	2	0.9	\$150
K†	18-26.5	½ x ¼	$\pm 0.7$	1.1	1.05	½	10¾	9-15/16	9-15/16	1	0.45	\$200
R†	26.5-40	3/8 x 2/32	$\pm 0.7$	1.1	1.05	½	11¾	8¾	8-23/32	1	0.45	\$250

<sup>1</sup>When ordering, specify suffix letter to indicate nominal coupling: A for 3 dB, C for 10 dB, D for 20 dB (example: S-band, 3 dB coupling, Model S752A).

<sup>2</sup>Directivity is at least 40 dB; swept-frequency tested.

<sup>3</sup>Mean coupling is the average of the maximum and minimum coupling values in the rated frequency range.

<sup>4</sup>Coupling variation over rated frequency range is not more than  $\pm 0.5$  dB about mean coupling ( $\pm 0.6$  dB for R752D).

<sup>5</sup>Auxiliary arm swr is 1.15 (1.2 for P-, K- and R-band units).

<sup>6</sup>Swept-frequency tested.

\*J752 Couplers operate to 5.3 GHz with reduced performance.

†Circular flange adapters: K-band (UG425/U), HP 11515A, \$35 each; R-band (UG-381/U), HP 11516A, \$40 each.



## TUNERS, PHASE SHIFTERS

Precision instruments for lab or general use  
Models 870A, 872A, 885A



## COAXIAL, WAVEGUIDE

### 870A Slide-Screw Tuners

Slide-screw tuners are used to match loads, terminations, etc., to the characteristic impedance of the transmission system. The HP 870A tuners consist of a waveguide slotted section with a precision carriage that supports an adjustable probe. The position and penetration of the probe is adjusted to set up a reflection which cancels an existing reflection in the system. An swr of 20 can be corrected to 1.02, and small swr's may be corrected exactly. Eight models cover the 2.6 to 40 GHz range. Price: HP 870A, \$150 to \$350.

### 872A Coaxial Slide-Screw Tuner

This tuner consists of a parallel plane line and a precision probe carriage and exhibits exceedingly low insertion loss. Carriage travel is at least one-half wavelength at 500 MHz, so any phase of reflection can be cancelled. Phase can be adjusted independent of magnitude, making the HP 872A much more convenient than double-stub tuners. Both probe penetration and position can be logged, so that settings may be repeated easily.

### Specifications, 872A

**Frequency range:** 500 to 4000 MHz.

**Correctable swr:** 5.

**Insertion loss at maximum correctable swr:** 0.5 dB or less.

**Impedance:** 50 ohms (Type N connectors, one male, one female).

**Weight:** net 17 lbs (7.7 kg); shipping 27 lbs (12.2 kg).

**Accessories available:** 11511A Shorting Jack, \$4; 11512A Shorting Plug, \$4.50.

**Price:** HP 872A, \$550.

### 885A Waveguide Phase Shifters

HP 885A Phase Shifters provide accurate, controllable phase variation in the J-, X- and P-band frequency ranges. They are particularly useful in microwave bridge circuits, where phase and amplitude must be adjusted independently. They also are used in the study of phased arrays.

The instruments have high accuracy over their entire phase range,  $-360$  to  $+360$  electrical degrees, have low power absorption, are simple to operate and require no charts or interpolation. They are sturdily built, comprising two rectangular-to-circular waveguide transitions with a dial-driven circular waveguide mid-section. These waveguide phase shifters are housed in case aluminum containers for extreme rigidity and durability.

### Specifications, 885A

HP Model	Frequency range (GHz)	Accuracy	Maximum insertion loss	Power (rating watts)	Price
J885A	5.30 - 8.20	3°	2 dB	10	\$550
X885A	8.20 - 12.4	2°, 8.2 - 10 GHz 3°, 10-12.4 GHz	1 dB, 8.2-10 GHz 2 dB, 10-12.4 GHz	10	\$425
P885A	12.4 - 18.0	4°	3 dB	5	\$600

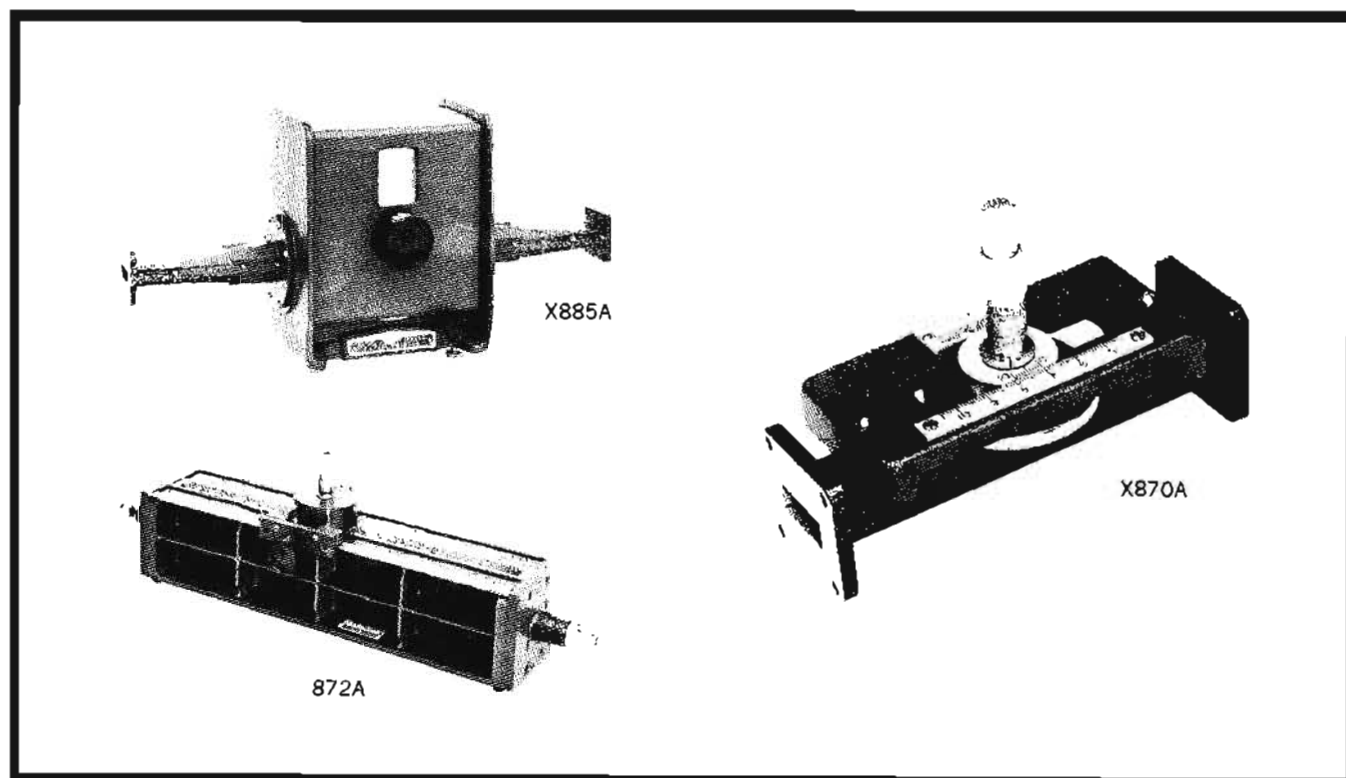

**TERMINATIONS AND SHORTS**

Versatile, convenient microwave instruments

Models 907A-914B and 920,X923A

**907A, 914 loads**

The HP 907A Coaxial Sliding Load is a movable, low-reflection termination for 50-ohm systems. It covers the frequency range of 1 to 18 GHz and can be moved at least one-half wavelength at 1 GHz. Load swr is less than 1.05 from 1.5 to 18 GHz, less than 1.1 from 1 to 1.5 GHz. For versatility, the 907A is furnished with adapters and center conductors for use with APC-7 and all type N connectors. Price: HP 907A, \$275.

Model 914 Moving Load consists of a section of waveguide in which is mounted a sliding, tapered low-reflection load. A plunger controls the position of the load, moving it at least one-half wavelength at the lowest waveguide frequency. Thus, the phase of the residual load reflection can be reversed, so that this reflection can be separated from the other small reflections in the system.

The waveguide sections of the moving loads are manufactured to very close tolerances to minimize the waveguide swr. All but S-band units are broached, for broaching is a linear cutting stroke which does not have the irregularities of milling cutters, etc. In addition, the guide dimensions are checked with precision gauges — air gauges from X- through R-bands. Eight models cover from 2.6 to 40 GHz; each has a locking mechanism which prevents accidental movement of the load. Hewlett-Packard 914 prices range from \$60 to \$275.

**908A, 909A, 910 Terminations**

Models 908A and 909A are low-reflection loads for ter-

minating 50-ohm coaxial systems in their characteristic impedance. Frequency ranges are dc to 4 GHz and dc to 18 GHz respectively; swr is less than 1.05 for the 908A, less than 1.05 to 4 GHz, 1.1 to 12.4 GHz, and 1.25 to 18 GHz for the 909A. Power ratings for the 908A and 909A are 0.5 and 2 watts respectively. The 908A is furnished with a type N male connector; the 909A, with an APC-7 or optional type N male or female. Price: HP 908A, \$35; HP 909A, \$75 (\$60 with type N connector).

The 910 Series is designed for terminating waveguide systems operating at average powers up to about 1 watt (1 kW peak). They may be used wherever a matched load is required, as in the measurement of reflection, discontinuities or obstacles in waveguide systems. Featuring low swr, the 910 Series covers the frequency range of 2.6 to 18 GHz in six models. Price: HP 910 Series, \$35 to \$90.

**X923A, 920A,B waveguide shorts**

Models X923A and 920A,B are convenient instruments for introducing a variable element in waveguide systems. Operating in X-band (8.2 to 12.4 GHz), the X923A combines fast phasing capability with a reference plane which is independent of frequency. The 920A,B are available in seven bands from 2.6 to 40 GHz excluding X-band; these units are phased with a lead screw. The waveguide sections are broached and checked to close tolerances to insure uniform reflection as the reference point is shifted. Price: HP X923A, \$75; HP 920A,B, \$85 to \$175.

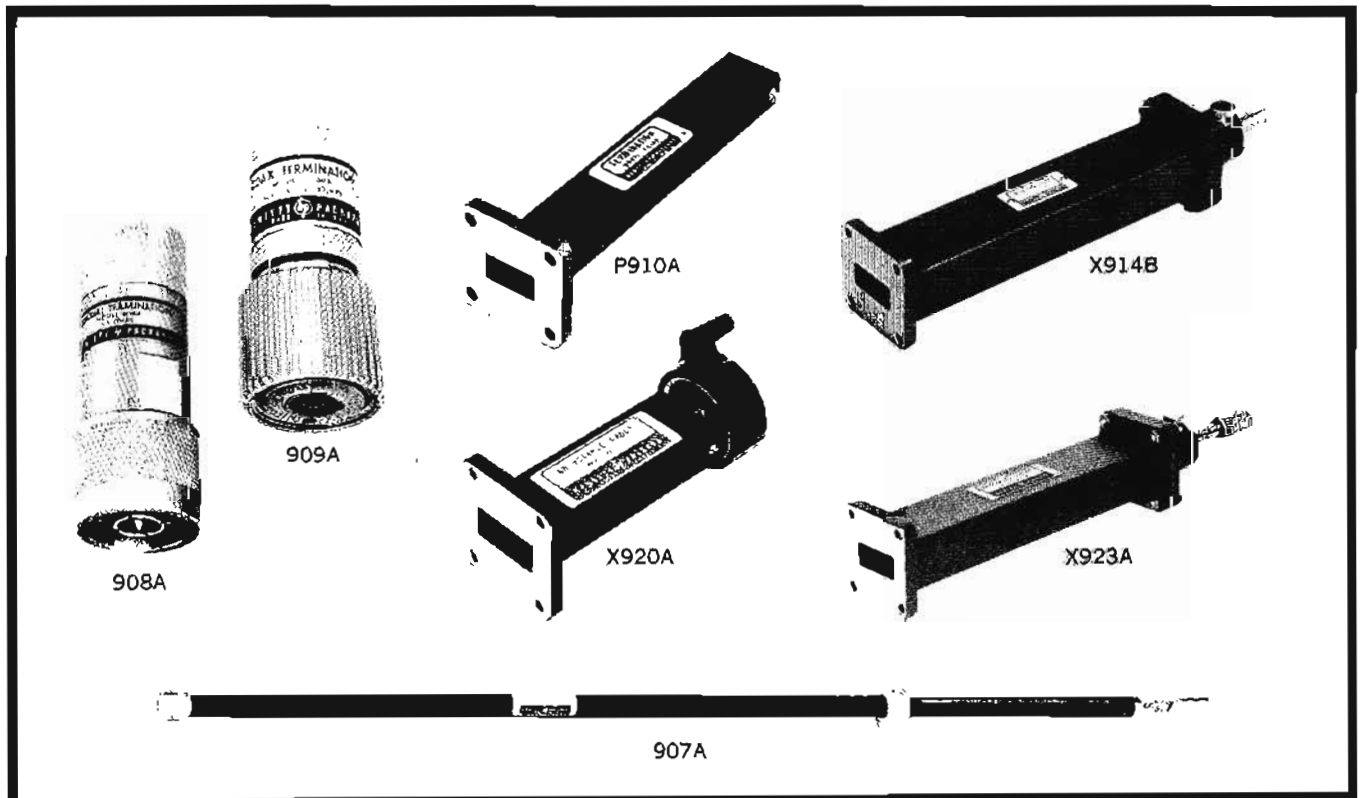

# MISCELLANEOUS EQUIPMENT

Increase flexibility of microwave measurements  
Models 281A/B, 292A/B, X913A, X930A, 11540A-11548A



### 281A,B; 292A,B Adapters

HP 281A,B Adapters transform waveguide impedance into 50-ohm coaxial impedance. Power can be transmitted in either direction, and each adapter covers the full frequency range of its waveguide band with swr less than 1.25. The 281A Adapter is fitted with a cover flange and brass type N female connector; the 281B, with a cover flange and an APC-7 or optional stainless steel type N female connector.

Models 292A,B Waveguide-to-Waveguide Adapters connect two different waveguide sizes with overlapping frequency ranges. The 292A consists of a short tapered section of waveguide. The 292B is broached waveguide with a step transition between waveguide sizes.

Specifications, 281A,B					
HP Model	Maximum swr	Frequency range (GHz)	Fits waveguide size		Price
			OD (In.)	(EIA)	
S281A	1.25	2.60 to 3.95	3 x 1½	WR284	\$50
G281A	1.25	3.95 to 5.85	2 x 1	WR187	\$40
J281A	1.25*	5.30 to 8.20	1½ x ¾	WR137	\$35
H281A	1.25	7.05 to 10.0	1¼ x ¾	WR112	\$30
X281A	1.25	8.20 to 12.4	1 x ½	WR90	\$25
X281B	1.25	8.20 to 12.4	1 x ½	WR90	\$60
P281B	1.25	12.4 to 18	0.702 x 0.391	WR62	\$75

\*1.3 from 5.3 to 5.5 GHz.

Specifications, 292A,B					
HP Model	SWR	Length		Frequency range (GHz)	Price
		(In.)	(mm)		
HX292B	1.05	1½	38	8.20 to 10.0	\$40
MX292B	1.05	2¾	60	10.0 to 12.4	\$50
MP292B	1.05	2¾	60	12.4 to 15.0	\$40
NP292A	1.05	2¾	60	15.0 to 18.0	\$40
NK292A	1.05	2¾	60	18.0 to 22.0	\$40

### X913A Termination

The X913A is a high-power termination which does not require cumbersome water connections. The unit will dissipate 500 watts average, 100 kW peak, and its swr over the full 8.2 to 12.4 GHz range is less than 1.05. Price: X913A, \$125.

### X930A Shorting Switch

Model X930A, 8.2 to 12.4 GHz, provides a removable short in a waveguide circuit. SWR is less than 1.02 in the "open" position, greater than 125 in the "short" position. Price: HP X930A, \$160.

### Waveguide Stand, Waveguide Clamps

Cast and machined from zinc alloy, the 11540A Waveguide Stand locks HP Waveguide Clamp at any height from 2¾" to 5¼" (70 to 133 mm). The stand is 2½" (64 mm) high, and the base measures 4¾" (121 mm) in diameter. Price: 11540A, \$3. The Waveguide Clamps are offered in nine sizes to fit waveguide equipment covering frequencies from 2.6 to 40 GHz. They consist of a molded plastic cradle with a center rod.

Specifications, Waveguide Clamps			
HP Model	Waveguide size		Price
	(outside dimensions, in.)	EIA	
11541A	3 x 1½	WR284	\$2.50
11542A	2 x 1	WR187	\$2.50
11543A	1½ x ¾	WR137	\$2.50
11544A	1¼ x ¾	WR112	\$2.50
11545A	1 x ½	WR 90	\$2.50
11546A	0.702 x 0.391	WR 62	\$2.50
11547A	½ x ¼	WR 42	\$2.50
11548A	0.360 x 0.220	WR 28	\$2.50

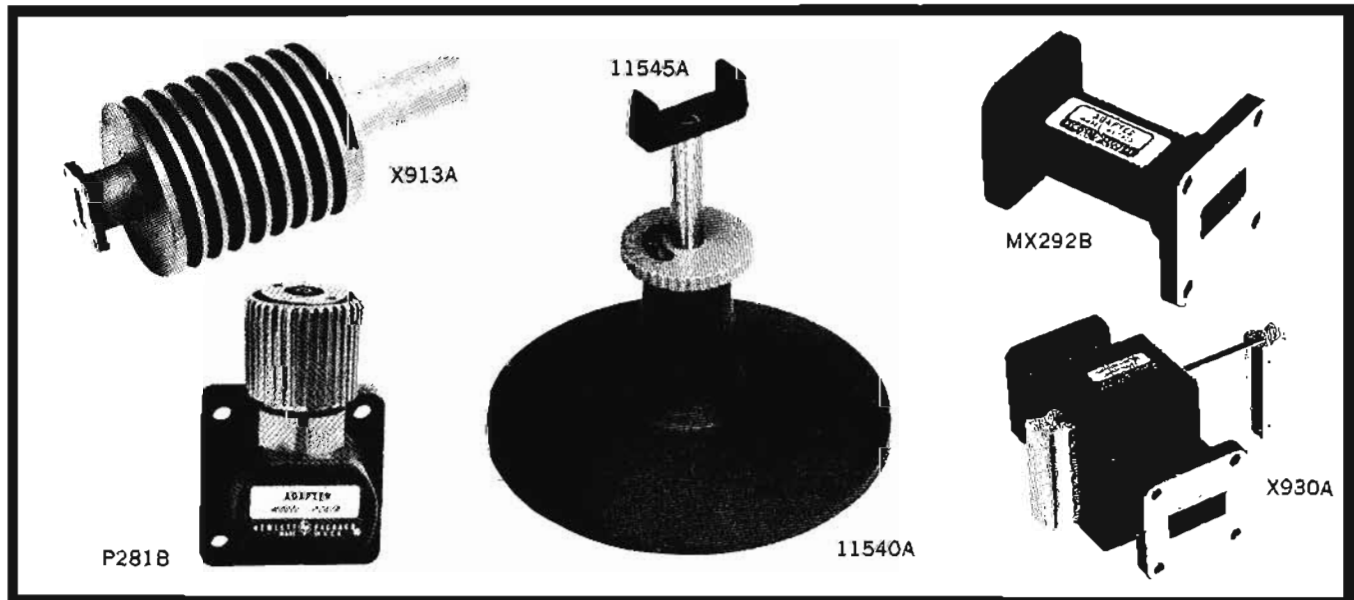



The aerial and underground pressurized cable plant of the modern telephone operating organization epitomizes the large low pressure system which lends itself to ultrasonic maintenance. Gaining momentum after World War II, all cable pressurization has resulted in overall reduction in outlay for cable plant maintenance. This is particularly true in the reduction of emergency repair time formerly encountered when rains entered the cable sheath to result in widespread service disruption. Modern telephone practice calls for the installation of compressor/dryer units supplying cable pressure in outlying areas. Flow indicators adjacent to these compressors provide telephone maintenance crews with constant readings as to the integrity of the cable. Additionally, contactor terminals and pressure regulators are employed throughout the plant.

The most common causes of leaks in cable plant are corrosion (particularly in coastal areas), electrolysis, squirrels, boring beetles, abrasion from wind and weather, hunters and outside workmen. Abrasion during installation and corrosion are the most frequent causes of cable sheath trouble in underground (ducted) passages.

Before the advent of ultrasonic leak detection, it was necessary on aerial cable for the craftsman to apply soap solution from the ground or suspended platform and to attempt to watch for bubbles.

For underground ducted cable, it was necessary to train personnel in sophisticated gradient measurement techniques to plot the leak location. However, the possibilities of error, even by the most technically-oriented personnel, frequently resulted in much more extensive excavation than necessary merely to repair the cable sheath.

### Ultrasonic inspection

Although the advent of highly portable

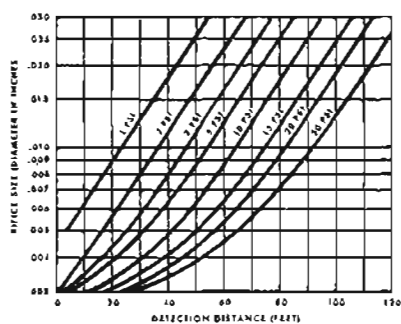

Leak detection distance vs. pressure and orifice size.

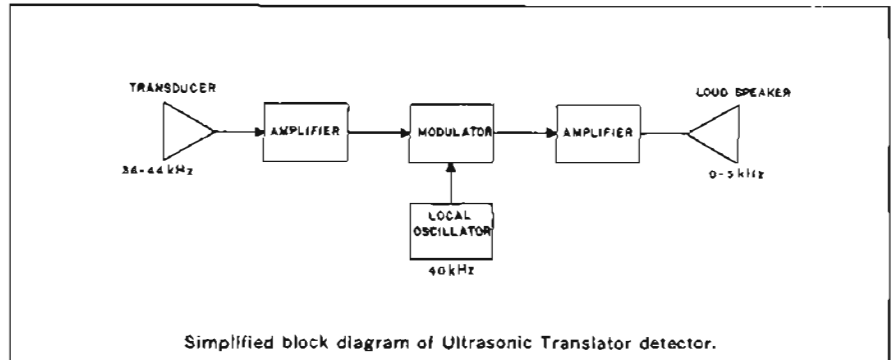

Ultrasonic Translator detectors permitted telephone craftsmen to locate sheath damage in pressurized cable from the ground, prudent supervisory management has established pre-inspection procedures to speed the operation further. It is typical practice, for example, for a splicer to perform the following preliminary steps on a cable failing to maintain nominal 10 psi.

(1) Place nitrogen cylinders, set to discharge 10 psi, at strategic locations along the right-of-way, (r.o.w.). Such cylinders often are allowed to remain 24 hours or longer in order to build up sufficient pressure within the cable.

(2) Take air pressure readings at selected points along the r.o.w. This practice is particularly important on such cables as cross-country toll lines which often traverse a line-of-sight across precipitous terrain.

(3) The readings taken at each pressure point are then plotted on graph paper. Each grid on the paper is selected by the craftsman to represent a known distance as determined from his cable plant maps.

(4) An alternative method of narrowing down the location of the leak is the cable pressurization computer, or gas pressure slide rule, as it is often called.

After the craftsman has narrowed down the location of the leak, or leaks, to within the length of three sections (between utility poles) or less, he commences his ultrasonic inspection in any of the following ways:

If he has isolated the trouble to within two city blocks or less, he would normally walk the route, using either the handheld probe or a 112WC ultrasonic probe extension fitted to a standard tree pruner section or a wheeled assembly containing an ultrasonic probe and pre-amplifier circuitry, (112BRC).

These accessories have 10 kv insulation transformers for the safety of the craftsman. In certain instances, an area-wide infestation of boring beetles will cause extensive damage and multiple leaks. In such cases, the inspection is often done from a moving vehicle. The telephone splicing cable car is still required for ultrasonic inspection on cables where the r.o.w. traverses canyons or deep gullies.

Estimates by officials at various telephone operating companies as to the economies achieved by the use of ultrasonic leak detection range from 50 to 80 percent and above.

Although the Delcon Ultrasonic Translator detector's transducer is responsive only to a 36 to 44 kHz acoustic bandwidth, the characteristic sounds of a phenomenon are preserved through translation and amplification. Thus, a typical 10 psi compressed air or nitrogen leak in pressurized cable, when translated, sounds exactly like the familiar hissing sound of a punctured innertube. Human experience, then, is the only data processing required.

### Training

The training of personnel in the use of ultrasonic leak detectors is minimal—the journeyman craftsman's common sense and work experience insure success. However, the ability to hear inaudible sounds is a new experience, and it is recommended that cable maintenance personnel receive a brief introduction to the instrument. Such an introduction can readily be set up by a telephone operating center. Some centers use cable vaults adjoining the central office. The foreman conducting the session will loosen air pressure valves to simulate leaks and then allow each of the craftsmen to find all of the leaks. The foreman instructs each craftsman to coordinate the direction of the probe with the sonic intensity.

## ULTRASONIC TRANSLATORS

Instruments for maintaining pressurized cable  
Models 116 and 4905A



## COMMUNICATIONS TEST EQUIPMENT

### Model 116

The Model 116 Ultrasonic Translator detector is a practical, lightweight system which consists of the basic detector unit, a directional probe, matching headphones, and a leather utility case. Information readout is through top quality headset, which provides craftsmen with readily interpreted and easily analyzed signal. A special rubber focusing probe enables user to pick up sounds from usually inaccessible locations such as leak sources between cables routed close to one another or on the bulkhead side of cable groups. The instrument is shipped with mercury cell batteries which provide from 360 to 500 hours of dependable operation. The detector can be carried in a pocket or by the web carrying strap.



Model 116

### Model 4905A

This lightweight, portable device is designed expressly for use in applications requiring a high degree of mobility. Offering operators hands-free efficiency, the 4905A has a built-in speaker, making it ideal for hard-hat situations. Furthermore, the reference meter is positioned on top of the instrument for easy viewing. The design of the 4905A is simple and functional—even an untrained operator can use it efficiently after reading the simple instructions on the cabinet. In addition, sturdy construction keeps the 4905A performing faithfully, year after year, despite the roughest handling.



Model 4905A

### Specifications, 116

**Construction:** rugged aluminum construction throughout entire instrument. Separate battery compartment permits battery replacement with disassembly. MIL-Spec glass reinforced epoxy printed circuit board. Cabinet has detachable side plate for major servicing. All components used are of premium quality. Total concept of design and construction is to provide for utmost reliability and long life in rugged field conditions such as hard climbing and limited crawl-space work encountered in industrial use.

**Circuitry:** completely transistorized 4.5 — volt circuitry for long battery life. Pull-Push switch and volume control are combined for ease of operation.

**Response:** frequencies between 36 kHz and 44 kHz are translated into audible sounds, while other sounds within the human hearing range are not detected by this instrument.

**Probe and coil cord:** hand-held; shielded against rf interference; output impedance 180 ohms; transistorized preamplifier; conical response  $\pm 11^\circ$  at 3 dB points. Supplied with a 6-foot coil cord employing latch-lock connectors.

**Probe size:**  $1\frac{3}{8}$ " dia. by  $6\frac{1}{4}$ " long, including protective model screened cap. Power to probe supplied through cord from main unit.

**Jack output:** 10 milliwatts into 600-ohm matched headphone. One volt rms minimum.

**Dimensions:** 4" wide,  $7\frac{1}{2}$ " high,  $1\frac{3}{4}$ " deep (102 x 19.1 x 4,45 cm).

**Probe:**  $1\frac{3}{8}$  inches diameter by  $6\frac{1}{4}$  inches in length.

**Batteries:** 3 cells of either mercury, or zinc carbon type. Standard "A-A" flashlight size.

**Battery life:** 360-500 hours from mercury cells.

**Weight:** net 7 lbs (3,2 kg); shipping 8 lbs (3,6 kg).

**Price:** Delcon Model 116, \$525.

### Specifications, 4905A

**Construction:** rugged aluminum chassis and case; stainless steel hardware throughout; Mil-Spec printed circuit board; quick-access battery compartment; detachable cabinet side-plate for servicing.

**Circuitry:** broad-range 4.5 V transistorized circuitry with RF filter provides 100 dB dynamic range; circuit gain controlled by a single knob.

**Frequency response:** translates frequencies between 36 kHz and 44 kHz into audible sounds; other sounds within audio range are screened out.

**Probe and coil cord:** hand-held; shielded against RF interference; output impedance 180 ohms; transistorized pre-amplifier; conical response  $\pm 11$  degrees at 3 dB points. Supplied with a six-foot coil cord employing latch-lock connectors. Probe size:  $1\frac{3}{8}$ " dia. x  $6\frac{1}{4}$ " long, including protective monel-screened cap. Power to probe supplied through cord from main unit.

**Meter:** ultrasonic sound intensity measured by output meter; sealed and gasketed to lock out dirt and contaminants; scale length 1.75 inches; linear calibration (0-100) on upper scale for logging relative measurements; lower scale calibrated from 0-30 dB.

**Speaker:** incorporates 2.5 inch speaker; sealed against moisture; nominal power to speaker 25 mW.

**Temperature range:** oscillator stability  $\pm 15$  Hz and signal to noise ratio within  $\pm 1$  dB from 0-55 degrees C.

**Headset jack:** auxiliary 600-ohm output headset jack.

**System weight:** net 6 lbs (2,7 kg); shipping weight 8 lbs (3,6 kg).

**Battery information:** three Eveready E-12 or equivalent (Mercury type).

**Battery life:** 360-500 hours.

**Dimensions:**  $8\frac{1}{4}$ " wide x  $4\frac{1}{2}$ " high x  $2\frac{1}{4}$ " deep (20,9 x 11,4 x 5,71 cm).

**Price:** Model 4905A, \$595.

## COMMUNICATIONS TEST EQUIPMENT



## REFLECTOR, WAND, PROBE

Accessories for use with ultrasonic detectors  
Models 112BRC, 112WC, 18000A

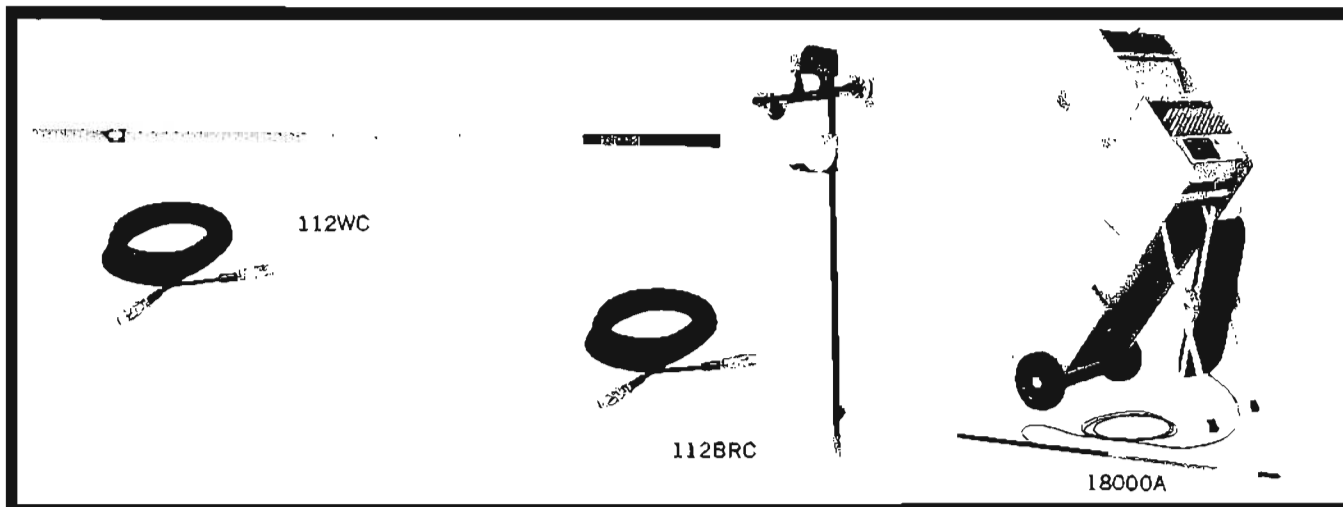

Accessories shown in this catalogue can be used with all models of Delcon Ultrasonic Translator detectors unless otherwise indicated.

### 112BRC Mobile Reflector

Designed to ride aerial cable, this unit is used with standard tree pruner poles and is provided with a 25-foot cord for connection to the Ultrasonic Translator detector. Pre-amplifier and local battery located in top housing. Unit equipped with two-wheel removable bridge assembly and sonic reflector. Insulation provided for 10 kV operator protection.

**System weight:** net 8 lbs (3,6 kg); shipping 10 lbs (4,5 kg).  
**Price:** Delcon 112BRC, \$225.

### 112WC Quik-Search Wand

The 112WC is a high-gain probe on a 6-foot long fiberglass pole designed to mate with pruner poles. Incorporating a preamplifier and 10 kV insulation, the 112WC permits a close inspection of overhead cables and terminals and for surveillance of manholes for leaks in cable, sleeves and splice cases.

**System weight:** net 5 lbs (2,3 kg); shipping 7 lbs (3,2 kg).  
**Price:** Delcon 112WC, \$185.

### 18000A Duct Probe

An accessory to Delcon Ultrasonic Translator detectors, the 18000A Duct Probe is designed for the precise and immediate location of leaks in underground (UG) pressurized cable. A hermetically sealed probe responsive to acoustic energy in the 36-44 kHz bandwidth provides the sensing element. Transported up the duct by means of three-foot long locking rods, into which coaxial cable is inserted, the probe's signal is translated and amplified by the basic Delcon instrument which remains at the manhole access. Plastic snap-on guides hold the coaxial cable firmly in its groove and center the probe and rod assembly atop the cable. The guides also reduce sliding friction within the duct, and prevent binding. In normal operating practice, the craftsmen utilize both

audio output and intensity meter to pinpoint the leak. Excavation point is quickly determined by counting the number of rods employed.

**Ultrasonic probe and preamp section:** sealed against water, sand and mud penetration. 1/2 inch outside diameter stainless steel housing. High sensitivity—high gain—low noise.

**Response:** frequencies between 36 and 44 kHz are translated into audible range. All other frequencies are rejected.

**Meter attachment:** rugged aluminum casting which slips over the outside edges of standard Delcon Translator detector. Signal amplifier and meter provide handy reference reading in pinpointing leaks. Avoids need to maintain a "listening watch" as probe is moved in duct-way. This attachment is not necessary when used with the 4917A or 4905A detectors.

**250 feet special extruded rod:** high-strength aluminum alloy, 36-inch lengths for easy handling, convenient reference, and optimum flexibility in following the duct-way. Accurately machined dovetail joints for fast, positive and rugged rod connections.

**100 molded plastic guides:** decrease sliding friction in duct and prevent binding. Insure positive lock at each joint. Lock coaxial cable into extruded rod.

**Wooden carrying case:** rugged "steamer trunk" construction with steel reinforced corners and wheels. Handy compartmentation keeps equipment in easy-to-use position.

**500-foot coaxial cable:** convenient, easy wind supply reel. Continuous readings through dependable noise-free slip rings. Signal level reference is constant throughout entire probing range since total cable length is always in circuit.

**Dimensions:** 12 1/2" wide, 47 1/2" high, 9 1/2" deep (31,7 x 120,6 x 24,1 cm).

**System weight:** net 95 lbs (43 kg); shipping 97 lbs (44 kg).

**Price:** Delcon 18000A, \$1195.

## CABLE FAULT LOCATING



## COMMUNICATIONS TEST EQUIPMENT

Faulted cable can generally be broken down into two major categories: open pairs or shorts, grounds and crosses. After the initial trouble report has been received and preliminary testing has been made, the field craftsman is ready to locate the fault. At this point, time is of utmost importance for restoration of service and to minimize direct labor costs. Only by careful analysis of the fault can the craftsman proceed in an organized and systematic manner. This, then, requires the proper instrument to perform both the important step of analysis as well as actually locating the fault.

### Selecting proper instruments

Shorts, grounds, and crosses are sometimes found by using a whole family of test sets — some of which may be obsolete. The Delcon Cable Fault Locators (4900 Series) are designed to eliminate the need for several instruments. Cables can be analyzed for exact resistance of fault by using the built-in ohmmeter feature on the Model 4901A. Without a jumble of accessories or extensive technical knowledge on the part of the user, faults can be easily and accurately pinpointed.

Versatility of the 4900 series Cable Fault Locators enable the operator to shoot trouble on aerial, buried, or underground cable. Aerial wire faults can also be quickly pinpointed. In addition to fault locating, buried or underground cable path and depth can accurately be determined without "spilling over" to other buried facilities.

High sensitivity of the 4900A and 4901A makes them very practical instruments for use on all types of communications cable — PIC, lead and coaxial.

### Non-communications uses

Power companies and utilities have found the Cable Fault Locator particularly valuable for use on underground residential distribution circuits (URD).

Series circuits such as street lighting or airport lighting are examples where the Delcon Cable Fault Locators can be used. Path and depth can be determined on all types of power cables.

Contractors are able to determine the path and depth of non-metallic duct or pipe by the simple procedure of inserting a flexible metal push rod the length of the course. Tone is applied to the rod and located with the wand.

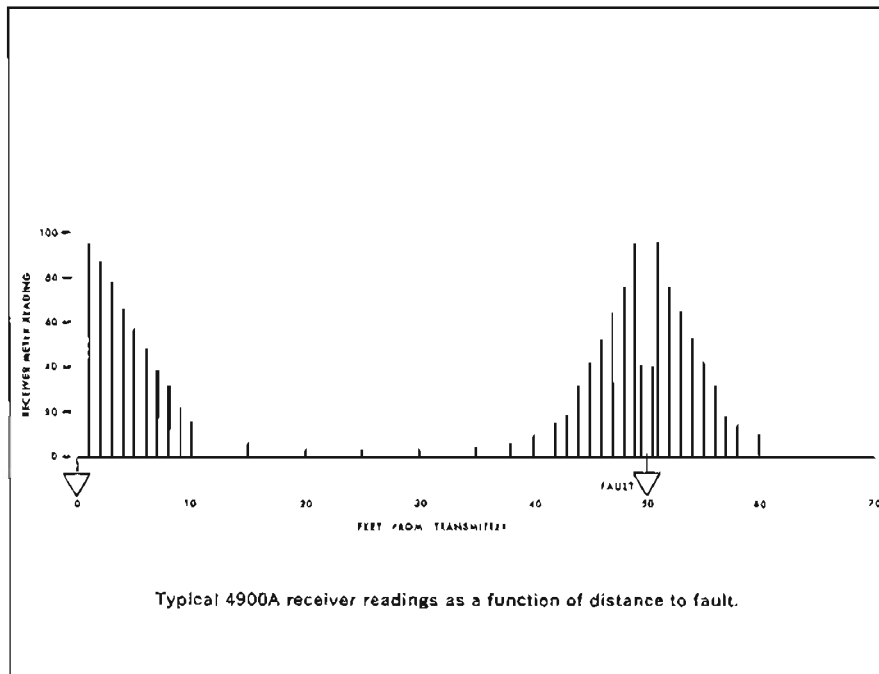

### Open pairs

When the reported trouble indicates the faulted cable pair to be open, the craftsman must further analyze the fault. First, he must understand cable makeup and related inter-conductor capacity. Exchange cable is designed and manufactured to have a nominal capacity of .083 microfarad per mile within each pair. Cable pair capacity will vary from this nominal value depending upon the tolerance established at the time of manufacture as well as the percentage of working pairs within the cable. The 4910B has been designed to accommodate a wide range of pair capacities by the incorporation of an adjustable "D"

Factor control and reference.

A "D" Factor reference of 1.0 has been established for a nominal cable capacity of .083 microfarad per mile in an average use condition. Some cables, most common being quaded toll, are designed to have a lower capacity of .067 microfarad per mile. Buried service wire and multiple line wire have pair capacities which differ from both the standard and low capacity cable.

### Principles of operation

The 4910B is a capacity meter that is unaffected by the inductance or resistance that is present in all lines.

The technique employed is "automatic charge sampling" which relates the charge placed on a length of wire to its capacity and hence the length. A dc voltage is applied to the test pair and the charge retained on the pair is then automatically transferred to a reference capacitor within the 4910B and the resulting voltage developed across this capacitor represents the length of the conductor under test. Final readout of the conductor length is provided by a high impedance voltmeter having an output meter indicating directly in feet.

The 4910B system measures total capacity of a circuit including bridge taps and built-out capacitors. Trouble shooting must therefore take these factors into account.

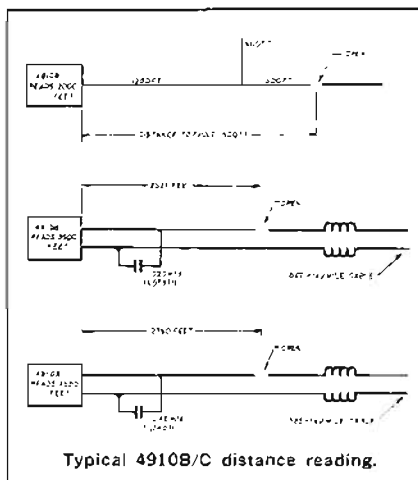





Operating on the principles of electromagnetic induction and earth voltage gradients, the series 4900A/4901A Fault Locators provide the craftsman a highly efficient means of troubleshooting. Because of their performance and the fact that they each perform test procedures previously requiring separate instruments, field experience by operating telephone companies indicate significant economies in cable maintenance and faster circuit restoration. Rugged construction makes the instruments ideal for all working and weather conditions.

The instruments are identical except that the model 4901A has an ohmmeter to assist the craftsman in preliminary analysis, proper grounding point selection, and in determining "drying

out" of resistance. Series 4900A/4901A instruments are shipped complete with all accessories necessary for troubleshooting buried cable plant. Also included is a 30-foot lead for use on aerial and block cable. A special jack on the receiver permits utilization of standard explorer coils already in telephone organizations' inventories. Ordinary lantern cells power the devices and interlock switches automatically prevent battery drain when the set is not in use. Similarly, battery voltage levels are compensated for optimum performance throughout the battery life. The accompanying instruction manual itself provides a short course in cable maintenance techniques in language and diagrams easily understood by all craftsmen.

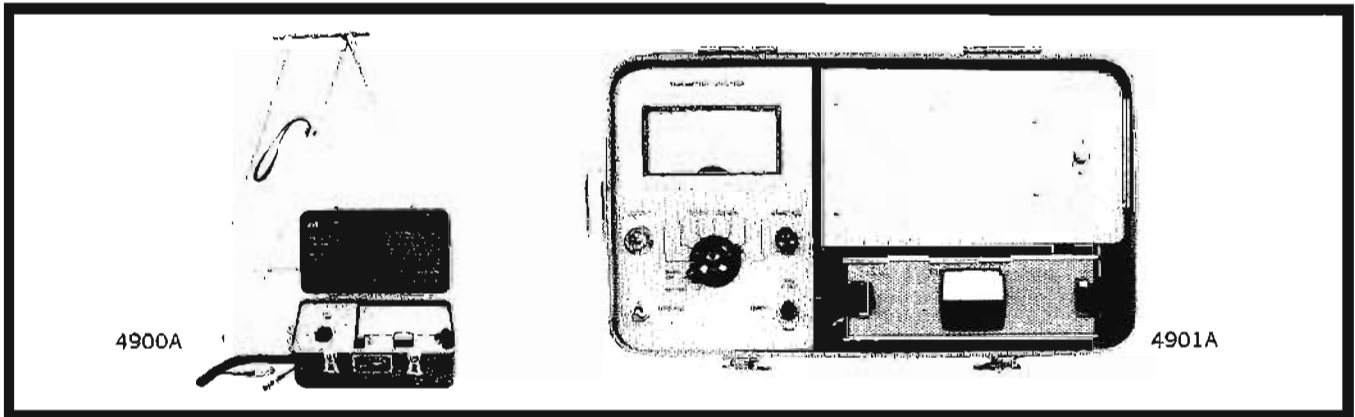

### Features

- Versatile: Does work of many different test sets. Detects faults in buried, aerial and underground cable.
- Fast, easy to use: Cuts detection time from hours to minutes. Equipment has simple controls, requires little preliminary instruction.
- Accurate: Pinpoints faults to within a fraction of an inch.
- Lightweight, portable: Total system weighs 19 lbs.  
Easily carried to remote cable sites.
- Durable: Quality construction throughout. Delivers top performance under roughest of handling.
- Battery-operated: Needs no outside power source. Solid-state circuitry uses little power, results in long battery life.
- Furnished complete: Needs no accessory equipment for most uses.

### Transmitter

Precision built, the transmitter features the latest solid state construction. Single control knobs and a flashing light automatically adjusts transmitter output. Transmitter generates a distinctive 990 Hz tone which is interrupted at 7 pulses per second. The unit is not damaged if batteries are reversed. Interlock switches prevent the unit from being stored with battery on.

### Receiver

The receiver is lightweight (2½ lbs.) and is easily carried around the neck of the operator. It is durable and rugged with all solid state construction. Top performance is possible under all field conditions. Protective circuits assure that the set will not be damaged if the batteries are accidentally reversed. Single control knobs adjusts the output level meter and speaker

volume. Selective response filters out 60 Hz and radio interference thus enabling the operator to pinpoint even the most difficult faults under varying soil conditions. A special design feature prevents unit from being stowed with battery turned to the "ON" position. A battery test-button checks on the condition of the battery.

### Carrying case

Compact and portable, the carrying case measures 9½ x 9 x 15 inches. It stows the receiver, built-in transmitter, lantern battery, test cables, and grounding rod.

The case is durable—built of heavy gage aluminum.

### Earth contact frame

The Earth Contact Frame is made of sturdy, lightweight, welded tubular aluminum. Stainless steel tines afford accurate pinpointing of earth return faults. When centerline of frame is directly over the fault, voltage across the tines cancels, giving a null at the receiver.

### Search wand

Constructed of strong, lightweight aluminum tubing, the search wand contains a pickup coil, wound on a ferrite core contained in bottom end of the wand. The wand is used for sensing the inductive field around the cable. This field allows the operator to locate path and depth, and to pinpoint crosses, grounds, and shorts.

**System weight:** net 22 lbs (10 kg); shipping 25 lbs (11.4 kg).

**Price:** Delcon 4900A, \$595. Delcon 4901A, \$695.

## OPEN PAIR FAULT LOCATOR

Pinpoints exact location of open pair  
Models 4910B, 4910C



**COMMUNICATIONS  
TEST EQUIPMENT**

This lightweight portable instrument is designed for the accurate location of open conductors in telephone cable pairs as distant as 100,000 feet (or 30,000 meters) from the test point. Standard or comparison pairs are not required, and the instrument indicates distance to the fault point directly in feet (or meters) on a durable, taut-band, mirrored meter. Employing the latest automatic charge sampling technique for maximum accuracy and minimum effect from cable induction, the all solid state 4910B/C is self-calibrating for use on all types of telephone cables having varying capacities. Simple to operate, the 4910B/C incorporates a line select switch permitting the tip and ring of a pair to be tested separately without the necessity of manually reversing test leads.

### Special features:

- Instrument automatically analyzes cable leakage resistance on each distance range to determine if test is valid.
- Internal voltmeter tests cable pair for presence of foreign voltage
- Line select switch permits instantaneous testing of either conductor
- Completely self-calibrating and self-testing circuitry assures accurate test results
- Exclusive "D-Factor" to adjust for varying cable capacities
- Monitor circuit automatically locks out reading when battery voltage falls below dependable operating level
- Interlock circuit automatically turns off all internal batteries when test cable is removed from instrument
- Test cable length is automatically subtracted providing readings in net distance to fault

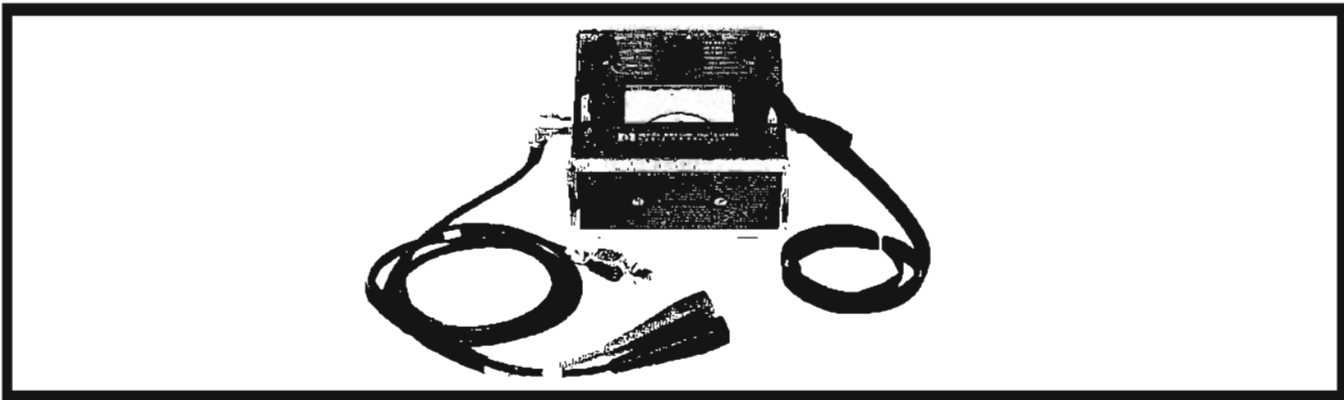

**Construction:** rugged aluminum construction is used throughout entire instrument. Cabinet has a detachable side plate for major servicing. Separate compartment permits battery replacement without disassembly.

**Circuit:** all solid state for long battery life and dependable operation. Employs automatic charge sampling circuitry for simplicity of operation and reliable reading.

**Meter:** utilizes specially designed taut-band meter for rugged field use. Individually calibrated, mirror type scale permits readings to be made with laboratory precision.

**Voltmeter:** indicates presence of any voltage from 1 to 200 volts on line. Automatically displays ac and either polarity of dc voltage.

**Ohmmeter:** Go/No-go type; automatically programmed for each distance range. Gives indication to operator when pair leakage resistance will affect distance readings.

### Distance ranges:

Scale	Accuracy
0-100 feet	± 1 foot
0-300 feet	± 3 feet
0-1000 feet	± 10 feet
0-3000 feet	± 30 feet
0-10,000 feet	± 100 feet
0-30,000 feet	± 300 feet
0-100,000 feet	± 5000 feet

**Batteries:** four standard 8.4 volt tubular Eveready E-126.

**Battery life:** 10,000 line tests (one year average service).

**Calibration:** the Model 4910B is self-calibrating to work with cables having a pair capacity from .056 to .138 microfarad per mile.

**Weight:** net, 5 lbs; shipping, 10 lbs.

**Size:** 7" x 5 3/4" x 5".

**Calibration:** the 4910C is self-calibrating to work with cables having a pair capacity from .035 to .087 microfarad per kilometer.

**Weight:** 2,27 kilograms. Shipping: 4,54 kilograms. Size: 17,8 cm x 14,5 cm x 12,5 cm.

**Price:** Model 4910B \$575.  
Model 4910C \$575.

### Distance ranges:

Scale	Accuracy
0-30 meters	± 0.3 meters
0-100 meters	± 1 meter
0-300 meters	± 3 meters
0-1000 meters	± 10 meters
0-3000 meters	± 30 meters
0-10,000 meters	± 100 meters
0-30,000 meters	± 1500 meters



The telegraph was the first method of electrical communication. In 1844 the first message was sent over a circuit. Shortly after this, the telephone was invented; and the "universal" and "standard" switchboards were introduced. Since then, electrical communications have been changed to electronic communications. The following information is aimed at the telephone portion of communications. It pertains only to Hewlett-Packard test equipment designed to improve, simplify and expedite telephone service. These objectives have been accomplished in several ways:

1. One instrument, or combination of instruments in one carrying case, will perform the duties of several previous instruments.
2. One function may be transferred to another by merely changing a switch position.
3. Battery-operated test equipment permits operation in the field.
4. A number of standard Western Electric terminals connected in parallel permit connection to different types of line equipment.

Generally in the United States, subscribers' loops are of nominal 900-ohm impedance. 600 ohms is an accepted trunk and tollboard impedance and is found in the many miles of open-wire carrier still in use. The CCITT\* does not recognize 900 ohms as a subscriber-loop impedance but recommends 600 for voice frequency applications and short-haul, open-wire carrier. Wire-cable carrier, typically short-haul, uses 135-ohm cable; many higher capacity systems use 135 ohms as an interface impedance on a group or super-group basis. The CCITT equivalent of this impedance is 150 ohms. Long-haul, coaxial-cable carrier systems use 75 ohms in the United States and in the CCITT recommended systems. The HP telephone voltmeter provides for all these impedances either balanced or unbalanced; and it also provides for either bridged or terminated conditions.

Since a holding function is desirable in many measurements, a holding coil is

provided which may be switched into the circuit on the 600 Hold and 900 Hold position. This provides an off-hook condition to hold the dialed line.

Connections are provided for attaching a lineman's handset for dialing. Once the connection has been established, the test instrument may be switched to one of the Hold positions. This will maintain the dialed connection but will remove the talking function and substitute the telephone oscillator or voltmeter. The input and output jacks accept standard 241, 309 and 310 Western Electric plugs, as well as the special connectors to receive the lineman's handset and dual banana binding posts for attaching wires or clip leads.

The theory of message-circuit noise measurement is based on a relative interfering effect of the noise on the subscriber's hearing. Because of the frequency response of the telephone subset

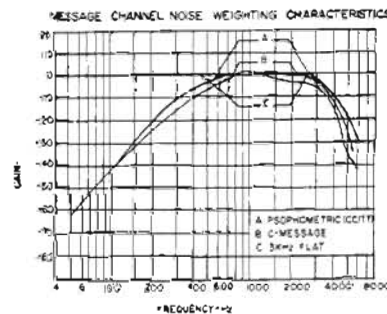

Figure 1. Noise weighting curves.

and the fact that the human ear responds differently to noise of various frequencies, a weighting function is assigned to

each frequency in proportion to its contribution to the interfering effect.

The weighting curve currently accepted as a U.S. standard is the Bell System C-Message weighting (see Figure 1). The unit used to define noise measured in this manner is dBRNC, meaning decibels above Reference Noise C-Message weighted. Reference noise is  $-90$  dBm at 1 kHz. The CCITT recommendation is psophometric weighting which has a slightly different curve and is referenced to 800 Hz. The measuring units for this weighting are picowatts psophometric, or pWp. A 3-MHz flat weighting refers to the broadband or flat voltmeter function, and a 3-kHz flat weighting provides for weighting over the range of voice frequencies only.

In addition to the quantitative measurement of noise, it is important to identify the source of the noise. Some indication of this can be obtained by noting the difference in noise on the 3-kHz flat and the C-Message weighting functions. A substantially higher reading in the 3-kHz flat mode usually indicates excessive power-line noise.

The measurement of all of these factors and the attenuator positions are designated in dB or dBm.

Hewlett-Packard telephone voltmeters incorporate these important features.

## HP 236A

The HP Model 236A Telephone Oscillator has all of the above mentioned Western Electric connectors for dialing

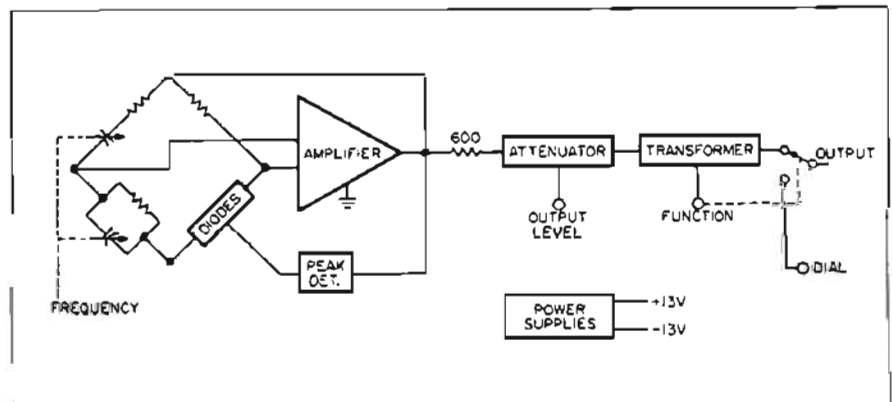

Figure 2. 236A block diagram.

\*Consultative Committee on International Telephone and Telegraph

and output. It incorporates the holding function for 600 and 900-ohm output impedances. It provides a 50-Hz to 20-kHz frequency range in the 600 and 900-ohm balanced output and 5-kHz to 560-kHz frequency range on the 135-ohm balanced output. Its power source may be a 115/230 V  $\pm 10\%$ , 50 to 1000 Hz external source or a 45 V dry-cell internal battery.

An interlock turns the power switch off when the cover is replaced. The oscillator's output level is adjustable from +10 to -31 dBm in 0.1 dB steps. The attenuator precedes the output transformer so the output impedance is not affected by the attenuation.

The HP 236A consists of an oscillator-amplifier, attenuator, power supply, meter circuit and a selective output circuit. Figure 2 shows the block diagram of this instrument.

The oscillator-amplifier operates as a typical solid-state HP RC oscillator (refer to page 320 of the oscillator section of this catalog). The front-panel output calibrator adjustment controls the output amplitude. Accurate metal film resistors are used to insure exact attenuations.

The output circuitry consists of a low and a high frequency output transformer, a holding coil, and parallel Western Electric output and dial connectors to insure a proper connection for any lineman's equipment.

### HP 3555A

The HP Model 3555A Telephone Voltmeter is a universal instrument for solving standard measurement problems existing in the telephone industry. The 3555A, in conjunction with the 236A Telephone

0°F to +120°F temperature range at humidities up to 95% RH.

The 3555A has selectable input impedances of 75, 135, 150, 600 and 900 ohms balanced, bridging or terminated for any impedance. The input connectors are standard Western Electric telephone jacks connected in parallel to fit any line equipment. Provisions are made for dial-through and hold operations (see Figure 3).

The balanced input impedances are accomplished by a differential amplifier, eliminating the normal repeat coil. This technique gives impedances of over 100 k ohms bridging with less than 0.05 dB bridging loss. Frequency response is flat over a 30-Hz to 3-MHz range. The input circuitry is protected against damage by ringing voltage, talk battery, telegraph and carrier battery.

The 3555A includes a filter which performs the C-message weighting function and a quasi-rms detector which adds the noise voltages on a power basis (the Oscillator constitutes a measuring system CCITT weighting filter and others are available on special order). The 3-kHz flat weighting is provided and the amplifier output may be connected to a recorder for long-term noise records, or will allow aural monitoring of the character of the noise.

Using the 3555A Telephone Voltmeter in combination with the 236A Telephone meter that may be used for all types of telephone equipment.

### HP 3550A

The HP 3550A Portable Test Set was designed specifically for transmission line testing and for such applications as align-

Patch Panel which adapts the oscillator and voltmeter to specific telephone usage. The patch panel has input and output sections acting as a source and receiver for the transmission line. The output section has an attenuator and an impedance-matching device which matches the oscillator's 600-ohm output impedance to 135, 600 and 900 transmission-line impedances. The center-tapped transformers give balanced outputs and inputs with bridging or terminated capabilities. The accurate attenuator gives 110 dB attenuation in 1 dB steps.

The H20-204B Option 02 Oscillator (frequency is 5 Hz to 560 kHz in five ranges, and the 403B Option 01 Voltmeter has ranges from 0.001 to 300 V full scale in 12 ranges. Thus, a complete telephone measuring set is contained in one portable package.

The H02-353A Patch Panel has special telephone jacks which will accommodate Western Electric 309 and 310 plugs. The Hold function is included along with a 23 dB attenuation position utilized by a lever switch.

The H03-353A Patch Panel will accommodate Western Electric 309, 310 and 241 plugs, and a lineman's handset. The Hold function is included along with a 23 dB attenuator.

The H05-332A and H05-334A are standard HP Models 332A and 334A Distortion Analyzers modified for use in the broadcast industry. The front-panel voltmeter reading is in dBm, and a switchable lowpass 30-kHz filter is added.

The low noise and wide dynamic range of the Model 312A Wave Analyzer make it useful for many telephone applications, including measurement of system flatness, analysis of distortion and intermodulation (cross-talk) in carrier systems, and measurement of noise levels. Model 313A Tracking Oscillator provides this function for the 312A Wave Analyzer. Semi-automatic plots of amplitude vs. frequency can be made using the Model 297A Sweep Drive and an X-Y Recorder.

Test equipment for microwave relay systems is manufactured in a wide variety by Hewlett-Packard. Three test sets (Models 623B, 624C, and 5636, page 351) each include a signal generator, power meter, and frequency meter for measurement of receiver sensitivity and selectivity, transmitter tuning and power level in the microwave region.

Microwave sweep oscillators, described on page 362, are available in special versions with frequency ranges that cover specific microwave communications bands.

Included in the oscillator, amplifier and voltmeter sections of this catalog are many instruments which may be used in the telephone industry.

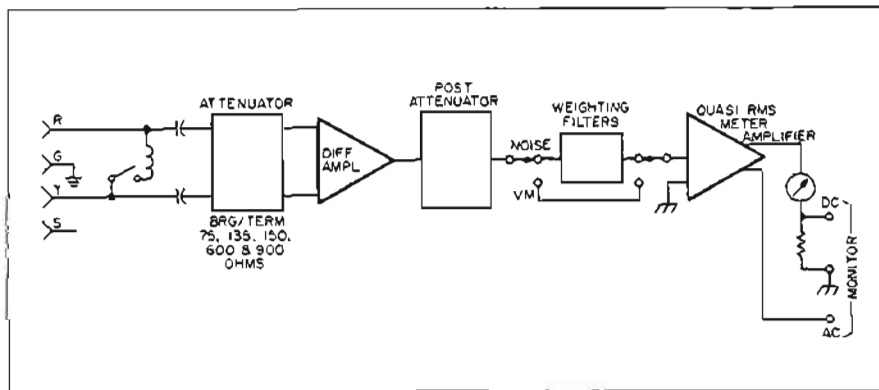
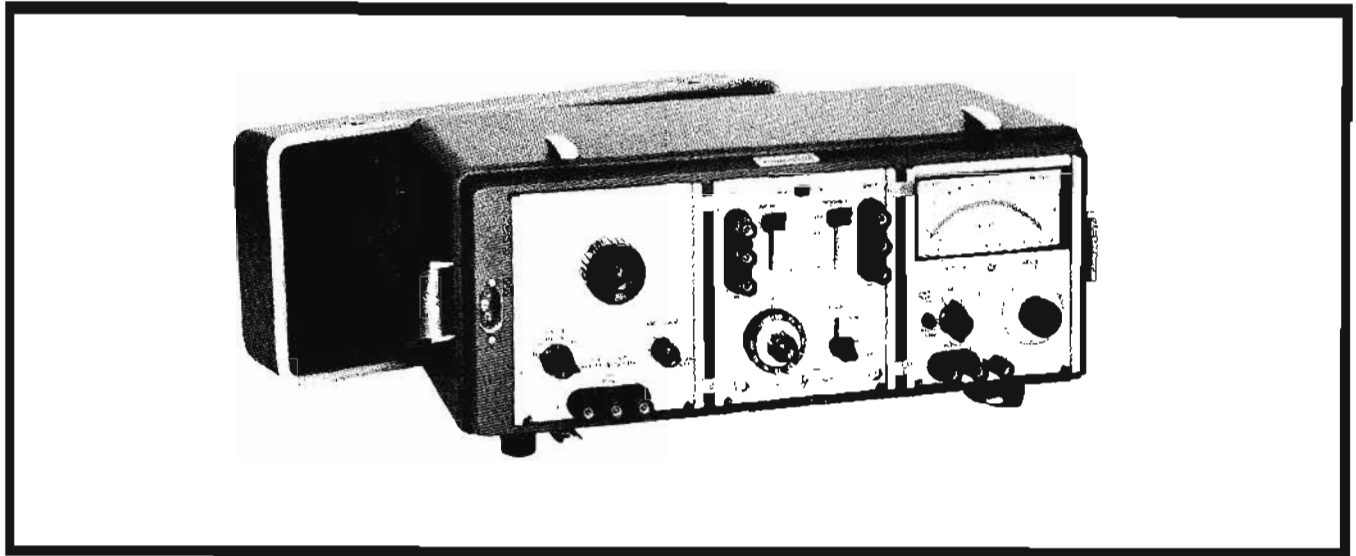

Figure 3. 3555A simplified block diagram.

Oscillator, allows rapid measurement of frequency response, gain and loss on voice and carrier facility and metallic noise and noise-to-ground of a voice or program facility. This telephone voltmeter features internal battery operation as well as CO battery or ac power. It is conveniently portable and completely enclosed in a splash-proof case, and is reliable over a

ment and maintenance of multi-channel communication systems. The test set consists of a wide-range oscillator, an electronic voltmeter and a patch panel containing attenuators and line-matching transformers. The instruments are operated from a rechargeable, battery power source, making it usable in the field.

The heart of this test set is the 353A

**PORTABLE TEST SET**  
 Measures transmission line characteristics  
 Model 3550A

**Features**

Oscillator — battery or ac operated. 5 Hz to 560 kHz, amplitude variation within  $\pm 3\%$ .

Voltmeter — battery or ac operated. 5 Hz to 2 MHz; reads in volts and dBm from  $-75$  to  $+52$  dBm.

Patch Panel (353A) — matches both oscillator and voltmeter to 135, 600 and 900-ohm systems; provides 110 dB attenuation in 10-dB and 1-dB steps.

Telephone Patch Panels (H02-353A, H03-353A): holding coils provided; 23 dB attenuator to conform to standard telephone levels of  $+7$  and  $-16$  dBm; 135, 600 and 900-ohm balanced input and output impedances; Dial/Talk function switch for use in active telephone circuits; standard Western Electric connectors.

**Uses**

Align and maintain multichannel communication systems.

Align and maintain long distance and local telephone circuits, both wet and dry.

Measure gain, attenuation and frequency response.

Measure amplifier characteristics without troublesome ground loops.

Excellent source of balanced  $\mu\text{V}$  signals for testing differential amplifiers.

The HP Model 3550A Portable Test Set is designed specifically to measure transmission line and system characteristics such as attenuation, frequency response or gain. It is particularly useful for lineup and maintenance of multichannel communication systems. Model 3550A contains a wide-range oscillator, a voltmeter, and a patch panel to match both the oscillator and the voltmeter to 135, 600 and 900-ohm lines. These instruments are mounted in a combining case equipped with a splash-proof cover. In addition, the oscillator, voltmeter and patch panel may be used separately whether they are in or removed from the combining case.

Both the oscillator and voltmeter are transistorized and operate from their internal rechargeable batteries or from the ac line. The batteries provide 40 hours of operation between

charges and are recharged automatically during operation from the ac line.

**Versatile components**

The oscillator has a frequency range of 5 Hz to 560 kHz, and its output is fully floating isolated from instrument case and power line (see 204B, page 324).

The voltmeter (see 403B, page 195) features a sensitive range, 1 mV full scale, for measuring voltages as small as 100  $\mu\text{V}$  rms from 5 Hz to 2 MHz. A dB scale, which is at the top of the meter face for better resolution, also permits measurement from  $-75$  to  $+52$  dBm.

The patch panel portion of the test set (353A) includes a precision attenuator, variable in 1 dB steps to 110 dB and two sets of impedance-matching transformers which match both oscillator and voltmeter to 135-, 600- and 900-ohm lines. One set of transformers also terminates the line in 10 k ohms for bridging measurements.

Both oscillator and voltmeter are solid-state and operate from their own internal rechargeable batteries or from the ac line. The batteries provide 40 hours of operation between charges and are recharged automatically during operation from the ac line.

**Telephone versions**

Two special versions of the 353A available on special order are the HP Model H02-353A and H03-353A Patch Panels designed specifically for the telephone industry. The Model H02 or H03 offer convenience in testing of telephone circuits, both active and passive. Both versions provide matching to 135-, 600- and 900-ohm balanced lines and can be mounted in place of the 353A in the 3550A Portable Test Set.

The H02-353A features a holding coil at the Send terminals, and the H03-353A features holding coils at the Rec and Send terminals which permit testing of active telephone lines at voice, as well as carrier frequencies. A single-step 23 dB attenuator enables the operator to select standard telephone levels of  $+7$  dBm and  $-16$  dBm. Jacks have been supplied to accept standard telephone type plugs.

## Specifications, 3550A

### Oscillator (H20-204B Option 02)

**Frequency range:** 5 Hz to 560 kHz in 5 ranges, vernier.  
**Dial accuracy:**  $\pm 3\%$ .  
**Frequency response:**  $\pm 0.25$  dB into rated load.  
**Output impedance:** 600 ohms.  
**Output:** 10 mW (2.5 V rms) into 600 ohms; 5 V rms open circuit; completely floating (isolated).  
**Distortion:** less than 1%.  
**Hum and noise:** less than 0.05%.  
**Temperature range:**  $-20^{\circ}\text{C}$  to  $+50^{\circ}\text{C}$ .  
**Price:** HP H20-204B Option 02, \$405 when purchased separately.

### Voltmeter (403B Option 01)

**Frequency range:** 5 Hz to 2 MHz.  
**Accuracy:** within  $\pm 0.2$  dB of full scale from 10 Hz to 1 MHz; within  $\pm 0.4$  dB of full scale from 5 to 10 Hz and 1 to 2 MHz, except  $\pm 0.8$  dB 1 to 2 MHz on the 300 V range ( $0^{\circ}\text{C}$  to  $+50^{\circ}\text{C}$ ).  
**Meter:** individually calibrated, taut band. Responds to average value of input waveform and is calibrated in the rms value of a sine wave.  
**Nominal input impedance:** 2 megohms; shunted by approximately 50 pF on 0.001 volt to 0.03 volt ranges, 25 pF on 0.1 volt to 300 volt ranges.  
**DC isolation:** signal ground may be  $\pm 500$  V dc from external chassis.  
**Price:** HP 403B Option 01, \$335 when purchased separately.

### Patch panel (353A)

**Input (receiver)**  
**Frequency range:** 50 Hz to 560 kHz.  
**Balance:** better than 70 dB at 60 Hz for 600 ohms and 900 ohms; better than 60 dB at 1 kHz for 600 and 900 ohms; better than 40 dB over entire frequency range for 135, 600 and 900 ohms.  
**Frequency response:**  $\pm 0.5$  dB, 50 Hz to 560 kHz.  
**Impedance:** 135, 600, 900 ohms and Bridging (10 k); center-tapped.  
**Insertion loss:** less than 0.75 dB at 1 kHz.  
**Maximum level:**  $+22$  dBm (10 V rms at 600 ohms).

### Output (source)

**Frequency range:** 50 Hz to 560 kHz.  
**Balance:** same as Input (receiver).  
**Frequency response:**  $\pm 0.5$  dB, 50 Hz to 560 kHz.  
**Impedance:** 135, 600 and 900 ohms, center-tapped.  
**Insertion loss:** less than 0.75 dB at 1 kHz.  
**Distortion:** less than 1%, 50 Hz to 560 kHz.  
**Maximum level:**  $+22$  dBm (10 V rms at 600 ohms).  
**Attenuation:** 110 dB in 1 dB steps; accuracy, 10 dB section: error less than  $\pm 0.25$  dB at any step; accuracy, 100 dB section: error is less than  $\pm 0.5$  dB at any step.

**Connectors:** two 3-terminal binding posts for external circuit connection and two BNC female connectors for oscillator and voltmeter connection.

**Price:** HP 353A, \$260 when purchased separately

### Available Telephone Patch Panels

#### Patch panel (H02-353A)

(Same as Model 353A except as indicated below).

**Attenuator:** 23 dB  $\pm 0.5$  dB (1-step slide switch).

#### Hold circuit (Send terminals)

**Frequency response:** 300 Hz to 3 kHz  $\pm 1/2$  dB, 1 kHz reference.

**DC resistance\*:** 240 ohms NOMINAL.

**Maximum dc current:** 100 mA.

**Maximum dc voltage:** 150 volts.

\*If additional dc resistance is required in the holding coil circuit, a resistor in series with the holding coil may be added.

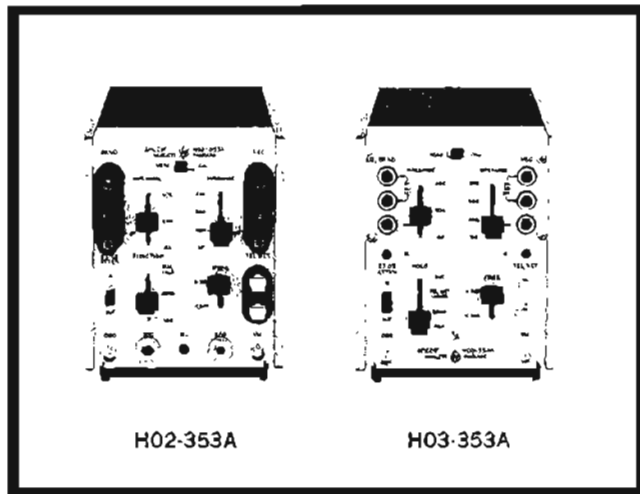

**Connectors:** special telephone jacks to accept Western Electric No. 309 and 310 plugs. Sleeve jack is connected to sleeve of jacks 309 and 310.

Two 3-terminal binding posts for external circuit connection.

Two-terminal (TEL SET) connector for handset.

Two BNC female connectors for Oscillator and Voltmeter connection.

**Price:** HP H02-3550A (H20-204B Option 02, H02-353A, and 403B Option 01), \$1270.

#### Patch panel (H03-353A)

(Same as Model 353A except as indicated below).

#### Hold circuit (Rec terminals)

**Frequency response:** 300 Hz to 3 kHz  $\pm 1/2$  dB, 1 kHz reference.

**DC resistance\*:** 240 ohms NOMINAL.

**Maximum dc current:** 100 mA.

**Maximum dc voltage:** 150 volts.

**Attenuation:** 23 dB  $\pm 0.5$  dB (1-step slide switch).

#### Hold circuit (Send terminals)

**Frequency response:** 300 Hz to 3 kHz  $\pm 1/2$  dB, 1 kHz reference.

**DC resistance\*:** 240 ohms NOMINAL.

**Maximum dc current:** 100 mA.

**Maximum dc voltage:** 150 volts.

**Connectors:** special telephone jacks to accept Western Electric No. 309, 310 and 241 at Send and Rec terminals. Sleeve jack is connected to sleeve of jacks 309 and 310.

Two-terminal (TEL SET) connector available for handset.

Two BNC female connectors for Oscillator and Voltmeter connection.

**Price:** HP H03-3550A (H20-204B Option 02, H03-353A and 403B Option 01), \$1270.

### General

**Power:** (identical specifications in both voltmeter and oscillator): 4 rechargeable batteries (furnished); 40-hour operation per recharge, up to 500 recharging cycles; recharging circuit is self-contained and functions automatically when instrument is operated from ac line (115 or 230 volts  $\pm 10\%$ , 50 to 1000 Hz, approx. 3 watts).

**Dimensions:** 8 $\frac{3}{8}$ " high, 19 $\frac{1}{4}$ " wide, 13 $\frac{1}{4}$ " deep (with cover installed) (213 x 489 x 367 mm).

**Weight:** net 30 lbs (13.5 kg); shipping 40 lbs (18 kg).

**Accessories available:** 10503A Cable, BNC-to-BNC, \$6.50; 11002A Test Leads, banana-plug-to-alligator clip, \$7.50.

**Accessories furnished:** detachable power cord; two 11035A Cables (1 foot long, dual banana-plug-to-BNC); splash-proof cover and storage compartment.

**Price:** HP 3550A (H20-204B Option 02, 353A and 403B Option 01), \$1150.



## TELEPHONE VOLTMETER

TMS when used with 236A Telephone Oscillator  
Model 3555A

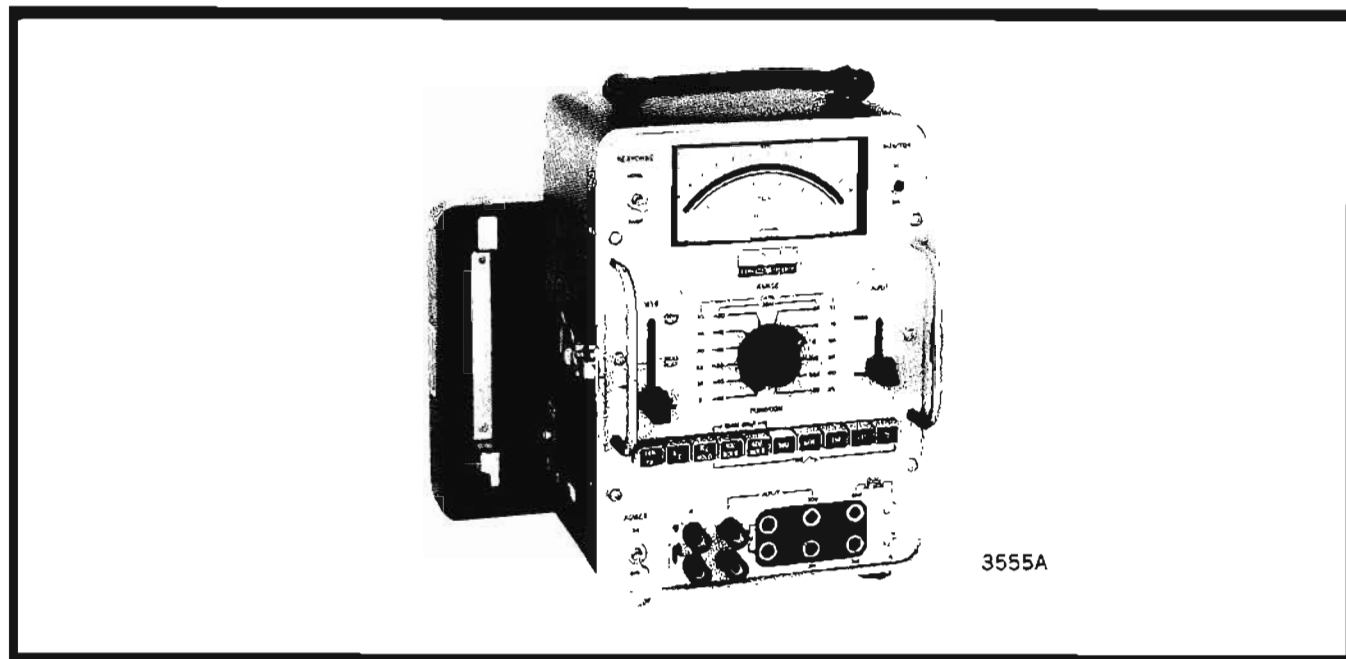

### Features

- Noise and level measurements in one package
- 3 kHz flat and C-message weighting network
- Flat frequency response (30 Hz to >3 MHz)
- Balanced 75, 135, 150, 600, 900 $\Omega$  and bridging (100 k $\Omega$ ) inputs
- Operates from CO battery, internal battery or ac line
- Standard telephone jacks
- Input protected against accidental overload
- Pushbutton function control
- Lightweight, portable, transistorized design

### Uses

- Align, test and maintain telephone circuits, both wet and dry
- Test gain and loss on voice, program or carrier facilities
- Check metallic noise and noise to ground
- Aural identification of source of noise
- Test wire, cable and coaxial carrier systems
- Make accurate and reliable measurements even at temperature and humidity extremes
- A complete transmission measuring set with 236A

### Description

The solid-state HP 3555A Telephone Voltmeter is a universal instrument for solving common measurement problems in the telephone industry. Its wide and flat frequency response makes it applicable for voice, program and carrier frequencies. The multiple input impedances, easily selected by pushbutton switches, make it usable for any type of tele-

phone transmission line in the United States or internationally.

The dial function permits connecting a lineman's handset for dialing. The Hold function will maintain an off-hook condition while the measurement is being made.

### Noise measurements

The 3555A Telephone Voltmeter includes a filter which performs the C-message weighting function (the CCITT weighting filter is available on special order) and a 3-kHz flat weighting for voice frequencies. These are selected by a lever-action switch. A quasi-rms detector adds the noise voltages on a power basis. Balance measurements may be easily made by measuring both noise-metallic and noise to ground. The sensitivity of the voltmeter is such that 0 dBRN can be measured directly. These measurements of noise give a quantitative measure of noise but do not identify the character or source.

### Source of noise

Induced power-line voltage, crosstalk and thermal sources present noise problems, and it is important to identify the source. Induced power-line voltage and its harmonics is prevalent. Some indication of this can be obtained by noting the difference in noise readings on the 3-kHz flat and on the C-message functions. A substantially higher reading in 3-kHz flat mode usually indicates the presence of excessive power-line noise. For further aid in identifying noise, the lineman's handset may be used to aurally monitor the character of the noise at the amplifier output. A recorder may be connected to the monitor jacks for observing long-term changes in noise level.



The 3555A Telephone Voltmeter selects the function by convenient pushbuttons, while range is selected by a rotary switch. Lever-action switches select weighting and bridging-terminate. A taut-band, individually calibrated logarithmic meter calibrated in dBm or dBRN indicates the voltage or noise level with 0.1 dB resolution on a linear dB scale.

### Differential amplifier provides balanced input

The balanced inputs are achieved by a differential amplifier circuit making possible bridging impedances over 100 k $\Omega$  giving less than 0.05 dB bridging loss. Frequency response is flat over the range of 30 Hz to 3 MHz.

Terminated measurements are provided by switching proper balanced termination across the incoming line and adjusting the gain accordingly for a dBm readout regardless of line impedance. This eliminates the necessity for correction factors. The accuracy of the termination is 1%, giving

a return loss of at least 40 dB. The terminations are all ac-coupled with a blocking capacitor to prevent a false holding condition and to avoid damage to the terminating resistors by the dc loop current. All input circuitry is protected against damage by ringing voltage, talk-battery, telegraph and carrier battery.

This instrument, which contains an internal battery, can also be operated from an ac power line or the 48 V CO battery. It includes a device for automatically turning off the power switch when the cover is replaced.

### Transmission measuring set (TMS)

The 3555A Telephone Voltmeter, when combined with the 236A Telephone Oscillator, can be used as a transmission measuring set. It is ideal for noise and level measurements on voice and carrier facilities. (See page 292).

## Specifications

### Level measurement

**Range:** -80 dBm to +30 dBm full scale in 12 ranges.

**Frequency range:** 30 Hz to >3 MHz.

**Level accuracy:** -60 to +30 dBm;  $\pm 0.1$  dB, 100 Hz to 20 kHz. -60 to +30 dBm;  $\pm 0.2$  dB, 30 Hz to 1 MHz (-3 dB at 3 MHz). -80 to -70 dBm;  $\pm 0.2$  dB, 30 Hz to 20 kHz.

### Input impedance

**Terminated:** 75, 135, 150, 600, 900 ohms  $\pm 1\%$  balanced.

**Bridging:** 100 k ohms balanced.

Voltmeter automatically reads in dBm regardless of impedance selected.

### Noise measurement

**Range:** +10 dBRn to +120 dBRn full scale in 12 ranges.

**Accuracy:**  $\pm 1$  dB.

**Weighting networks:** 3 MHz flat, 3 kHz flat, C-message (reference noise -90 dBm at 1 kHz), 1951 CCIF (CCITT) (optional) (other networks available on special order.)

### Input Impedance

**Noise metallic:** 75, 135, 150, 600, 900 ohms  $\pm 1\%$  balanced.

**Bridging:** 100 k ohms balanced.

**Noise to ground:** 80 k ohms across line; 100 k ohms to ground.

### General

#### Input balance

>70 dB, 30 Hz to 30 kHz.

>60 dB, 30 kHz to 100 kHz.

>40 dB, 100 kHz to 3 MHz.

**Input isolation:**  $\pm 500$  V dc between input and chassis ground. Input circuit will withstand 48 V dc CO battery with superimposed 90 V rms 20 Hz ringing voltage, or  $\pm 130$  V carrier supply.

**Residual noise:** -60 dBm range,  $< -80$  dBm; -30 dBm range,  $< -100$  dBm (3 kHz flat and C-message weighting only).

**DC holding coil:** 700 ohms  $\pm 10\%$  dc resistance; 60 mA max. loop current at 100 Hz.

**AC monitor:** 1 V rms with 10 k ohms output impedance. Output available at dial jacks.

**DC monitor:** 1 V with 2 k ohms output impedance. Jack accepts 310 plug.

**Input jacks:** accepts standard 241, 309 and 310 plugs. Binding posts accept banana plugs, spade lugs, phone tips or bare wires. Binding posts with shorting link for sleeve and ground terminals.

**Dial jacks:** accepts standard 309 and 310 plugs. Clip posts accept Western Electric 1011B lineman's handset.

**Operating temperature range:** 0°F to 120°F, 95% R.H. at 100°F.

**Power requirements:** 115 V  $\pm 10\%$  50 to 1000 Hz 1 W, or single NEDA 202 45 V "B" battery (included). 48 V CO battery at jack accepting 310 plug (tip negative).

**Dimensions:** 7 $\frac{3}{4}$ " wide, 10 $\frac{1}{2}$ " high, 8" deep (196,8 x 266,7 x 203,2 mm).

**Weight:** net: 11 lbs (5 kg); shipping, 15 lbs (6,8 kg).

**Price:** HP 3555A, \$525.



## TELEPHONE OSCILLATOR

Wide-range telephone test oscillator

Model 236A

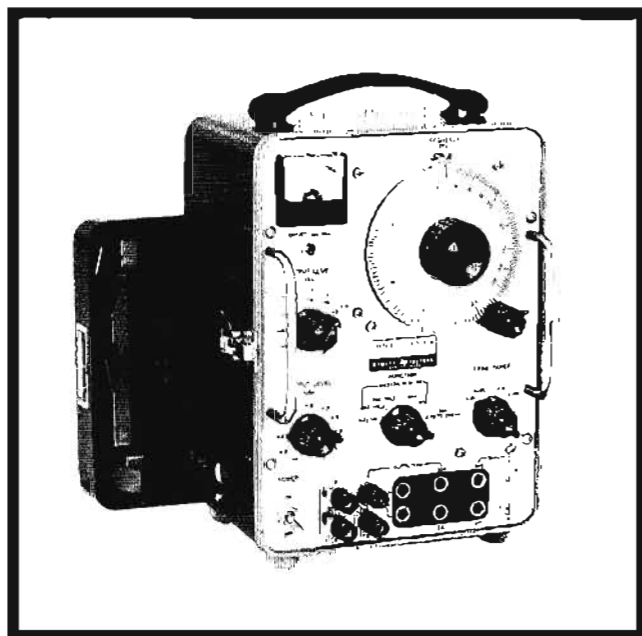

The solid-state HP 236A Telephone Test Oscillator is designed specifically to deliver transmission test signals. It is particularly useful for line-up and maintenance of telephone voice and carrier systems.

Any frequency between 50 Hz and 560 kHz may be selected in four ranges to an accuracy of  $\pm 3\%$ . Frequency response is flat over the entire range at any attenuator setting. The oscillator is fully transistorized, and internal heat production is small, resulting in unusually low warmup drift. Advanced feedback techniques insure excellent frequency and amplitude stability even under temperature extremes. Its output is fully floating and balanced, isolated from power-line ground and instrument case. Low-current drain, solid-state circuitry results in exceptionally long battery life with hum and noise 65 dB below total output.

Output jacks are standard telephone types to facilitate patching into standard test boards. A front-panel switch selects 135, 600 or 900-ohm output impedance. These outputs are balanced to ground and the impedance of each is controlled over the specified frequency range. The phase angle of the output impedance is low to maintain a true resistive source.

The output circuit includes two transformers preceded by step attenuators which, together, adjust output power over a 41 dB range (+10 to -31 dBm), in 10 dBm, 1 dBm, and 0.1 dBm steps having an overall accuracy of 0.1 dB over the entire range.

A front-panel control permits calibration of the output power level. Frequency response of the instrument is better than  $\pm 0.3$  dB.

A front-panel meter monitors the 45 volt dry cell battery or the 115/230 V ac regulated power supply. The dry cell will provide in excess of 180 hours of operation of the oscillator on a 3 hr/day discharge cycle at 70°F.

### Features:

- Flat frequency response
- +10 to -31 dBm output in 0.1 dBm steps
- Balanced outputs, 135-600-900 ohms
- Standard telephone jacks
- Hookswitch control
- Holding coil and dial jacks
- Operates from battery or ac line
- Lightweight, portable, transistorized design

### Uses:

- Align, test and maintain telephone circuits, both wet and dry
- Align, test and maintain carrier systems
- Test manual switchboards and PBX systems
- Make accurate and reliable measurements even at temperature and humidity extremes
- Balanced signal source for bridges

### Specifications

**Frequency range:** 50 Hz to 560 kHz in 4 ranges.

**Frequency dial accuracy:**  $\pm 3\%$ .

**Frequency response:**  $\pm 0.3$  dB, 50 Hz to 560 kHz, 60°-80°F.  
 $\pm 0.5$  dB, 50 Hz to 560 kHz, 32°-120°F.

**Output power:** +10 to -30 dBm in 0.1 dBm steps.

**Output power accuracy:**  $\pm 0.2$  dB at 1 kHz, 60°-80°F.

**Output level accuracy:**  $\pm 0.2$  dB, +10 to -31 dBm.

**Distortion:** at least 40 dB below fundamental output.

**Noise:** at least 65 dB below total output or -90 dBm, whichever is greater.

**Output circuit:** balanced and floating. May be operated up to  $\pm 500$  V dc above case ground.

**Output impedance:** 600 and 900 ohms  $\pm 5\%$ , 50 Hz to 20 kHz. 135 ohms  $\pm 10\%$ , 5 kHz to 560 kHz.

**Output balance:** 600 and 900 ohms; 70 dB at 100 Hz, 55 dB at 3 kHz. 135 ohms; 50 dB at 5 kHz, 30 dB at 560 kHz.

**Output connectors:** jacks to accept WESTERN ELECTRIC No. 241, 309 and 310 plugs. Standard banana jacks on  $\frac{3}{4}$ " spacing for tip, ring, sleeve and case ground with removable shorting link between sleeve and ground terminals.

**Dial connectors:** jacks to accept WESTERN ELECTRIC 309 and 310 plugs. Clip posts on  $\frac{3}{4}$ " centers for WESTERN ELECTRIC 1011B lineman's handset clips.

**Hold circuit:** 600 and 900 ohms only, 100 Hz to 20 kHz, 700 ohms dc resistance, 60 mA max. current.

**Power supply:** 115 or 230 V  $\pm 10\%$ , 50 to 1000 Hz, approx. 1 watt. Internal 45 V dry cell (furnished) gives 180 hr. operation on a 3 hr/day discharge cycle at 70°F.

**Dimensions:**  $7\frac{3}{4}$ " wide,  $10\frac{1}{2}$ " high,  $8\frac{1}{16}$ " deep (196,9 x 266,7 x 204,8 mm).

**Weight:** net 13.5 lbs (6,1 kg); shipping 14 lbs (6,4 kg).

**Price:** HP 236A, \$525.

# DISTORTION ANALYZERS

Meet FCC requirements  
Models H05-332A, H05-334A



COMMUNICATIONS  
TEST EQUIPMENT

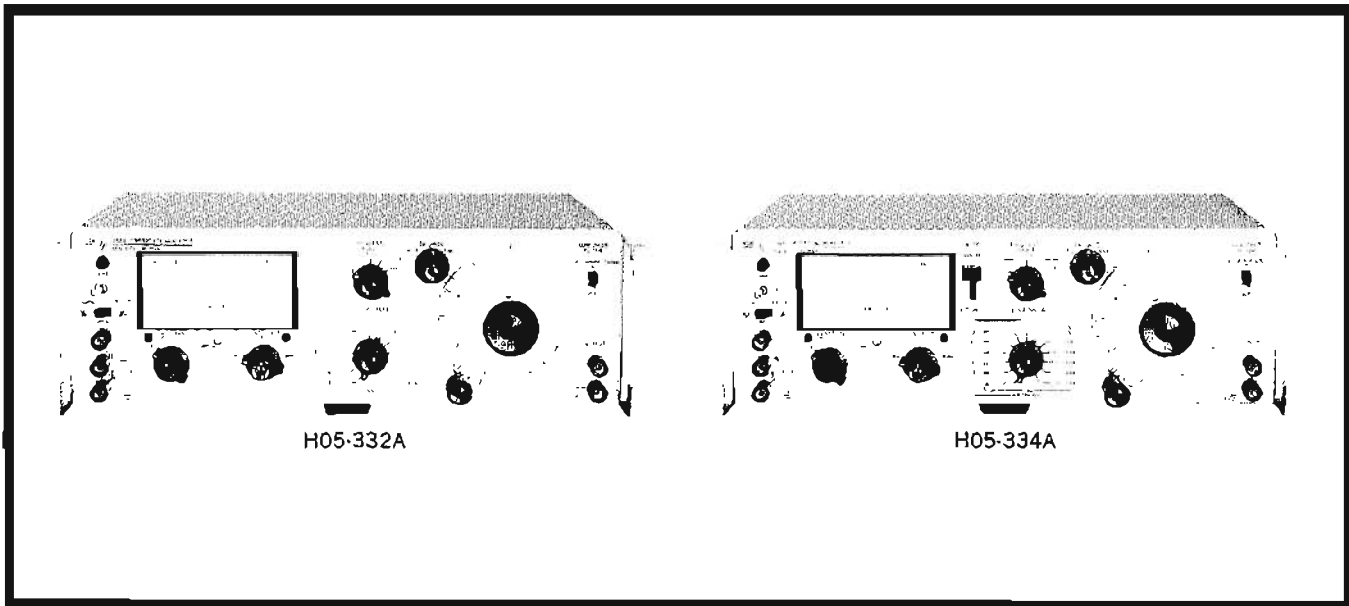

## Accurate distortion readings

Two solid-state distortion analyzers offer extended frequency range, greater set level sensitivity, improved selectivity, greater overall accuracy, and unprecedented ease of use. The units meet FCC requirements on broadcast distortion levels. Both models measure total distortion down to 0.1% full scale. The Model H05-334A features automatic fundamental nulling (>80 dB rejection). The H05-332A and 334A have a switchable low pass filter to reduce the effect of unwanted high frequencies (noise etc.) when measuring lower frequency signals with high accuracy. Also included is a 3 MHz voltmeter, 300  $\mu$ V to 300 V full scale. Both models have an AM detector covering 550 kHz to >65 MHz at carrier levels as low as 1 V. Refer to Table 1 for comparison of features available in Hewlett-Packard Distortion Analyzers that specifically fit the requirements of the broadcast industry.

## Automatic fundamental nulling

Automatic fundamental nulling speeds up the normally time-consuming portion of the measurement. This is done by

manually nulling with the coarse tuning and balance controls to less than 10% of the Set-Level Reference. The automatic mode is used to complete rejection of the fundamental on more sensitive ranges without any further manual tuning.

## Specifications

See page 392 and 393 for detailed specifications. The specifications for the HP H05-332A and H05-334A are the same as the specifications for the standard HP 332A and 334A except:

A low-pass filter is added in the Model H05-332A and is substituted for a high-pass filter in the Model H05-334A.

**Low-pass filter:** 4 pole, 3 dB down at 30 kHz.

**Meter range switch:** calibrated and referenced in dBm (0 dBm = 1 mW into 600  $\Omega$ ).

**Price:** HP H05-332A, \$730.

**Price:** HP H05-334A (same as H05-332A except with automatic fundamental nulling), \$875.

Frequency range	Voltmeter range	Automatic fundamental nulling	Low pass filter	High pass filter	AM detector	Model	Price
5 Hz to 30 kHz, switchable to 3 MHz	300 $\mu$ V-300 V rms full scale in 13 ranges, 10 dB per range, with flat response 5 Hz to MHz		X		X	H05-332A	\$730
5 Hz to 600 kHz, harmonic indications to 3 MHz, in 7 ranges					X	332A	\$620
5 Hz to 30 kHz, switchable to 3 MHz		X	X		X	H05-334A	\$875
5 Hz to 600 kHz, harmonic indications to 3 MHz, in 7 ranges		X		X	X	334A	\$790



## WAVE ANALYZER; OSCILLATOR

Signal analysis to 18 MHz; tracking oscillator

Models 312A; 313A

### 312A Waveform analyzer

Model 312A permits analysis of complex wave forms whose spectra extend to 18 MHz. The Wave Analyzer utilizes the tuned-voltmeter technique to separate the various components of an input signal so that the fundamental, harmonics, and intermodulation products can be located and measured. The instrument is particularly well suited for measurement in communications systems accommodating basebands to 18 MHz. The high selectivity, wide dynamic range, and high sensitivity of the 312A greatly simplify measurements such as distortion, attenuation, cross talk, frequency response, etc. Versatility is enhanced by three selectable bandwidths: 200 Hz for maximum resolution, 1,000 Hz for simple calculations of noise power per Hz, and 3,000 Hz for easy location of signals or operation as a receiver.

For maximum flexibility, the 312A input may be operated either balanced or unbalanced. In the Terminated mode, the input signal is terminated in a selectable impedance of 50, 60, 75, 124, 135, 150, or 600 ohms. The meter indicates power in dBm absorbed by the selected impedance; in the 50 ohms position, the meter also indicates voltage. In the Bridged mode, the input impedance is 20 kilohms balanced and 10 kilohms unbalanced. When bridging an externally terminated transmission line of the same impedance selected on the 312A, the meter indicates dBm. In this mode the 312A can also indicate voltage by selecting the Volts Calibrated position of the Impedance Selector. The high impedance 11530A Probe can also be used for bridging measurements to eliminate the loading effect of the input cable on the circuit under test. The Probe has zero insertion loss, so the meter reads directly.

The 312A has two signal attenuators. One, at the input, prevents the applied signal from overdriving the input amplifier. The second attenuator provides up to 60 dB attenuation in the IF channel and permits measurement of signals which are at least 65 dB below a full-scale reference set on the 0-dB position. Thus, low level distortion products may be readily measured.

Tuning is accomplished in 18 overlapping bands. The frequency to which the analyzer is tuned is indicated by an in-line digital readout with 10-Hz resolution. Both the tuning and readout are referenced against a crystal oscillator whose stability is better than  $\pm 2 \times 10^{-6}$  per week; thus, a high degree of accuracy and stability, both long and short term, are assured. To facilitate measurements on drifting signals, an AFC mode can be selected. In this mode, the Analyzer locks to and follows input signals with drift rates as high as 100 Hz/second. Lock range is at least  $\pm 3$  kHz.

A carrier reinsertion oscillator is included in the 312A to provide for the demodulation of upper or lower single side-band signals (using 3-kHz bandwidth). The demodulated signal is available for aural or recording purposes. The analyzer also receives and detects AM signals.

For use with equipment requiring only 75-ohm unbalanced measurements, the HP H01-312A provides wave analysis capability to 22 MHz.

### 313A Tracking oscillator

HP 313A Tracking Oscillator provides a restored frequency or tracking output to complement the 312A Wave Analyzer. The frequency of this output signal automatically tracks the center of the 312A passband, so the 312A and 313A are excellent for analyzing the frequency response characteristics of amplifiers, filters, etc.

The output of the 313A is extremely flat over the entire frequency range and is calibrated in dBm. A precision 100-dB attenuator, calibrated in 0.1 dB steps, adds to the versatility. Together with the wide dynamic range of the 312A, the output flexibility of the 313A permits high values of gain and attenuation to be checked easily and accurately.

The 313A can also be used to provide increased amplitude resolution by expanding selectable 2-dB ranges of the 312A meter to full scale on the 313A meter. Any 2-dB range between  $-6$  and  $+3$  dB on the 312A meter may be selected for display. Amplitude variations as small as 0.01 dB can be resolved. Thus, minute variations in filter passbands or long-term gain variations in a communications channel can be analyzed easily.

The 313A can be operated as a signal source independent of the 312A Wave Analyzer. As such, the 313A has a frequency range from 10 kHz to 22 MHz in a single band. The output is extremely flat over the entire range and is adjustable from  $+10$  to  $-99.9$  dBm.

### Specifications, 312A

**Frequency range:** 10 kHz to 18 MHz in 18 overlapping bands; 200 kHz overlap between bands; usable to 1 kHz with 200 Hz bandwidth.

**Frequency accuracy:**  $\pm 10$  Hz  $\pm$  time base accuracy; frequency indicated on in-line digital readout with  $\pm 10$ -Hz resolution.

**Time base stability:** aging rate: less than  $\pm 2$  parts in  $10^6$  per week; as a function of ambient temperature:  $+15$  to  $+35^\circ\text{C}$ , less than  $\pm 20$  parts in  $10^6$ ;  $0$  to  $+55^\circ\text{C}$ , less than  $\pm 100$  parts in  $10^6$ ; as a function of line voltage: less than  $\pm 1$  part in  $10^4$  for changes of  $\pm 10\%$ .

#### Selectivity:

	200 Hz Bandwidth	1000 Hz Bandwidth	3000 Hz Bandwidth
Rejection	Frequency (Hz)	Frequency (Hz)	Frequency (Hz)
3 dB	$200 \pm 10\%$	$1000 \pm 10\%$	$3000 \pm 10\%$
60 dB	$< 448$	$< 2240$	$< 6680$

**Automatic frequency control:** dynamic hold-in range, at least  $\pm 3$  kHz; tracking speed, 100 Hz/sec maximum; locks on signals as low as 60 dB below zero reference with Amplitude Reference switch set to 0 dB.

**Amplitude range:**  $-97$  to  $+23$  dBm full scale ( $-107$  to  $+13$  dB, for 600-ohm impedance);  $3 \mu\text{V}$  to  $3 \text{ V}$  full scale (50-ohm impedance); selected by Reference Level and Amplitude Range switches in steps of 10 dB or 3:1; noise level, referred to input (200 Hz bandwidth),  $-120$  dBm (50-150 $\Omega$ ),  $-130$  dBm (600 $\Omega$ ).

#### Amplitude accuracy:

**Reference level (matched 50 $\Omega$  input):** 10 kHz to 10 MHz,  $\pm 0.2$  dB ( $\pm 2\%$  of full scale); 10 to 18 MHz,  $\pm 0.5$  dB ( $\pm 5\%$  of full scale).

**Amplitude range:**  $\pm 0.1$  dB ( $\pm 1\%$  of full scale).

**Meter tracking:**  $\pm 0.1$  dB to  $-10$  dB ( $\pm 1\%$  of full scale).

**Internal calibrator output:**  $-40$  dBm into 75 $\Omega$  termination at 1 MHz; stability better than  $\pm 0.1$  dBm; output connector, BNC female.

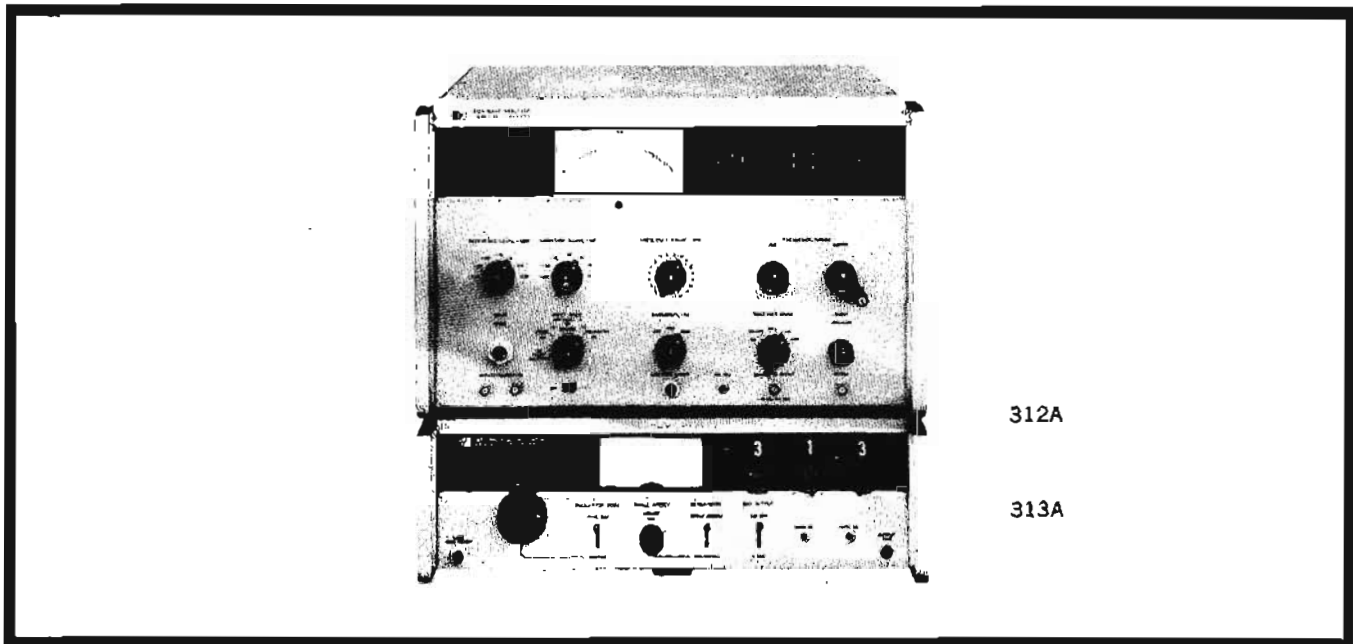

312A

313A

**Input impedance:** 50, 60, 75, 124, 135, 150, 600  $\Omega$ , or bridging, balanced or unbalanced, selectable at front panel; bridging resistance, 20 k $\Omega$  balanced, 10 k $\Omega$  unbalanced; input capacitance less than 18 pF balanced, 35 pF unbalanced; input connector, BNC female (2).

**Common mode rejection balanced input:** 1 kHz to 5 MHz, greater than 40 dB; 5 to 18 MHz, greater than 30 dB.

**Residual responses:** at least 75 dB below full-scale reference set on 0-dB position of Amplitude Range switch.

**Harmonic distortion:** for input signals  $\geq 1$  MHz, at least 65 dB below full-scale reference set on 0-dB position of Amplitude Range switch; for input signals  $< 1$  MHz, at least 55 dB below full-scale reference set on 0-dB position of Amplitude Range switch.

**Receiver functions:** internal carrier reinsertion oscillator is provided for demodulation of either normal or inverted single-side-band signals; AM signals also can be detected; audio output level, 0.5 V rms into at least 10 k $\Omega$  with full-scale meter indication; beat note output provides zero-beat output indication of center passband for CW signals; output connector, BNC female.

**Recorder output:** 1 V dc into an open circuit from 1 k $\Omega$  source impedance, for single-ended recorders; tracking accuracy, better than  $\pm 0.1$  dB to 20 dB below full scale reference on 0-dB position of Amplitude Range switch; output connector, BNC female.

**Auxiliary outputs:** 1 MHz: approximately 1 V p-p into 1 k $\Omega$ ; output connector, BNC female; 30 MHz: approximately 40 to 60 mV rms into 50 $\Omega$ ; output connector, BNC female; local oscillator (30 to 48 MHz): approximately 60 to 80 mV rms into 50 $\Omega$ ; output connector, BNC female.

**Dimensions:** 16 $\frac{3}{4}$ " wide, 10 $\frac{3}{4}$ " high, 18 $\frac{3}{8}$ " deep (426 x 274 x 467 mm); hardware furnished for conversion to rack mount 19" wide, 10-15/32" high, 16 $\frac{3}{8}$ " deep behind panel (483 x 266 x 416 mm).

**Power:** 115 to 230 V  $\pm 10\%$ , 50 to 400 Hz, 90 W.

**Weight:** net 45 lbs (20.3 kg); shipping 52 lbs (23.4 kg).

**Accessory available:** 11530A Probe, provides 40 k $\Omega$  input resistance shunted by  $< 5$  pF balanced, 20 k $\Omega$  shunted by  $< 10$  pF unbalanced; 0 dB insertion loss.

**Price:** HP 312A, \$3900; HP C01-312A, furnished with WE-465C coaxial input connector and WE-477B coaxial connector for the internal calibrator output, \$3975.

### Specifications, H01-312A

(same as 312A except)

**Frequency range:** 10 kHz to 22 MHz in 22 overlapping bands.

**Reference level (matched 75 $\Omega$  input):** 10 kHz to 10 MHz,  $\pm 0.1$  dB; 10 to 22 MHz,  $\pm 0.2$  dB.

**Input impedance:** 75 $\Omega$ , or bridging, unbalanced, selectable at front panel; bridging resistance, 10 k $\Omega$ ; input capacitance  $< 35$  pF; input connector, WE-477B.

**Receiver output connector:** accepts WE-289B twin plug.

**Internal calibrator output connector:** WE-477B.

**Price:** HP H01-312A, \$3900.

### Specifications, 313A

**Frequency range:** tracking oscillator: same as 312A (usable to 5 kHz), tracks 312A tuning; internal oscillator: 10 kHz to 22 MHz in one band.

**Frequency accuracy and stability:** tracking oscillator: frequency accuracy same as 312A  $+35 \pm 4$  Hz; frequency stability same as 312A (time base  $\pm 100$  Hz/ $^{\circ}$ C); internal oscillator: 1% dial accuracy.

**Output:** 0 or +10 dBm maximum (selectable on front panel) into 50 $\Omega$ .

**Harmonic distortion:** more than 40 dB below fundamental.

**Non-harmonic distortion:** tracking oscillator: more than 50 dB below fundamental 10 kHz to 22 MHz at 25 $^{\circ}$ C  $\pm 10^{\circ}$ C, more than 40 dB down, 0 $^{\circ}$ C to 50 $^{\circ}$ C; internal oscillator: more than 50 dB below fundamental 10 kHz to 22 MHz from 0 $^{\circ}$ C to 50 $^{\circ}$ C.

**Frequency response:**  $\pm 0.1$  dB 10 kHz to 22 MHz.

**Meter mode:** 312A expand: range, -1 to +1 dB; tracking error,  $\pm 0.05$  dB over full 2-dB range (meter expands any 2-dB range of 312A meter indication from -6 to +3 dB, using 312A recorder output); output monitor: meter indicates input to attenuator (relative to maximum output) in dB; accuracy,  $\pm 2\%$  of full scale; frequency response,  $\pm 0.1$  dB.

**Output attenuator:** 3-section attenuator provides 0 to 99.9 dB attenuation in 0.1-dB steps.

**Output attenuator accuracy:** 0.9-dB section (0.1-dB steps),  $\pm 0.02$  dB; 9-dB section (1-dB steps),  $\pm 0.1$  dB; 90-dB section (10-dB steps),  $\pm 0.1$  dB to 50 dB,  $\pm 0.2$  dB to 90 dB; overall accuracy,  $\pm 0.22$  dB to 60 dB,  $\pm 0.32$  dB to 90 dB.

**Output impedance:** 75 $\Omega$  unbalanced; BNC female connector.

**Power:** 115 or 230 V, 50 to 400 Hz, 30 W maximum.

**Dimensions:** 16 $\frac{3}{4}$ " wide, 5 $\frac{1}{2}$ " high, 18 $\frac{3}{8}$ " deep (426 x 141 x 467 mm); hardware furnished for conversion to rack mount 19" wide, 5-7/32" high, 16 $\frac{3}{8}$ " deep behind panel (483 x 133 x 416 mm).

**Weight:** net 25 lbs (11.3 kg); shipping 30 lbs (13.5 kg).

**Price:** HP 313A, \$1250.

**Option 01:** output impedance 50 $\Omega$  unbalanced; BNC Female connector, no charge.



**A brief description of the Vertical-Interval Test Signals being transmitted in TV channels for continuously checking channel quality.**

The Television networks, the individual TV broadcasting stations, and the Bell System are all concerned with improving the quality of the picture seen by the viewing public. In the day-to-day operation of the television networks, many changes are made in the interconnection of these transmission facilities. This includes changes in broadcasters' facilities, changes in local Telephone Company facilities, and changes in inter-exchange channels. Although designed for long term stable performance, no part of the overall network is immune to trouble. Since many of these troubles are temporary or transient, it is desirable that they be located quickly, while they are present. This means that trouble location must be done on an in-service basis, rather than by tests made on an out-of-service basis after the program is over.

In addition, it is often difficult either to identify or to diagnose troubles from observation of the normal picture signal. Some more rigorous test signal is needed. The technique which seems to come closest to meeting these requirements and seems to hold the most promise is the use of Vertical Interval Test Signals (VITS).

### Vertical Interval Test Signals

VITS are signals generated and transmitted by equipment provided by the broadcasters. They are keyed into designated lines during the vertical blanking interval of the picture. These signals are then transmitted along with the normal picture signal. They may be observed, and/or photographed, at appropriate existing monitoring locations by network, Telephone Company, and local station personnel. They can be used for quantitative measurements. Appropriate comparison or analysis of the test results should facilitate trouble location during actual service.

Vertical Interval Test Signals may be inserted on any of the lines between 16 and 20 of either or both fields. The three VITS waveforms are:

1. **Multiburst:** White bar followed by bursts of 0.5 MHz, 1.5 MHz, 2.0 MHz, 3.0 MHz, 3.6 MHz, and 4.2 MHz. This signal gives a quick check of the amplitude vs. frequency response of the channel. The six bursts have equal amplitudes if the response is correct, and vice versa. To check that the multiburst baseline is at the same level for each burst, the sine waves are removed with a low pass filter.

2. **Sine-Squared Pulse and Bar:** Pulse with sine-squared shape and half-amplitude duration of either 0.125  $\mu$ sec (T pulse), 0.0625  $\mu$ sec (T/2 pulse), or 0.25  $\mu$ sec (2 T pulse), followed by bar with sine-squared leading and trailing edges and duration of one-half line. A symmetrical sine-squared pulse indicates that the phase characteristic of the channel is correct, and vice versa. Droop on the top of the bar indicates poor mid-frequency response. Overshoots or ringing indicate poor transient response.

3. **Modulated Stairsteps:** 10 equal steps going from black level to white level with burst of 3.58 MHz sine wave on each step. This signal is used for checking the channel for differential gain (variations in gain with signal amplitude) and differential phase. Low frequency Differential gain is checked by filtering out the 3.58 MHz sine waves with a low pass filter and checking the steps for equal amplitudes. Differential gain at 3.58 MHz is checked by filtering out the steps with a band pass filter and checking the bursts for equal amplitudes.

### Types of distortion

Both black-and-white and color television are degraded by distortion in the following characteristics of the transmission system:

1. **Frequency response (amplitude vs. frequency):** High frequency rolloff

which starts at too low a frequency or occurs at too fast a rate causes the TV picture to look soft and lack detail. Color TV viewing tests have indicated that viewers can detect amplitude variations of only 1 or 2 dB in the frequency response, if the variations occur near the color subcarrier frequency.

2. **Phase Response (phase vs. frequency):** The phase response of a transmission system should be linear with frequency (constant time delay for all frequencies) up to 4.2 MHz and beyond. Deviations will cause lack of clarity and, in color, hue shift. Phase delay distortions as small as  $\pm 0.1 \mu$ sec at the higher frequencies are easily detected by viewers.

3. **Transient Response:** Transient response includes both amplitude and phase response. If the phase characteristics of the system are not ideal, a black bar may appear at the leading or trailing edge of a sharp black-to-white transition. In a color picture, hue will be shifted with respect to outline; e.g., the red of an apple will be shifted with respect to the outline of the apple. Poor low-frequency response may cause streaking in the picture.

4. **Differential Gain and Differential Phase (gain and phase vs. signal amplitude):** Variations in gain with signal amplitude will cause white or black areas to shift towards gray, or color desaturation and a washed-out appearance. Variations in phase with amplitude are most harmful to color signals, and result in hue shift as a function of signal amplitude: saturated yellow, for example, may appear green or orange, so that a dress which appears yellow in dim light may change to green or orange in bright light.

In the VITS system, frequency response is checked by the multiburst signal, phase and transient responses are checked by the sine-squared pulse and bar, and differential gain and phase are detected by modulated stairsteps.

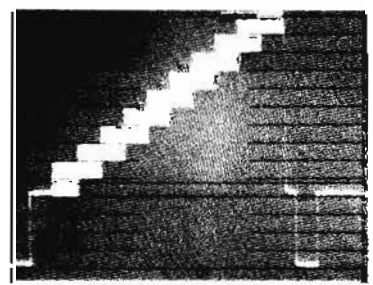
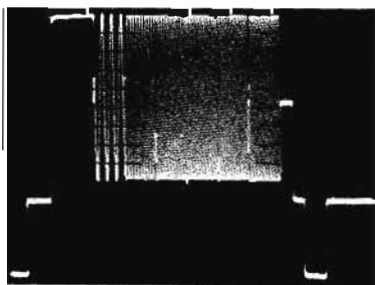

Oscillograms made with HP Model 191A TV Waveform Oscilloscope displaying Vertical Interval Test Signals; Multiburst Signal (left), Sine-squared Pulse and Bar (center), and Modulated Stairstep (right).

## TV WAVEFORM OSCILLOSCOPE

### Precision Measurement of VITS and Video Signals

Models 191A, 192A



**COMMUNICATIONS  
TEST EQUIPMENT**

Displaying the TV video waveform and the new test signals, and making accurate measurements of them, calls for an oscilloscope with special capabilities, plus unusual accuracy and stability. These requirements are met by the HP Model 191A Television Waveform Oscilloscope which displays and measures black-and-white and color TV video signals and VITS.

#### Video and test signals

TV picture information occurs at a rate of 30 pictures, or frames, per second, each frame consisting of two fields of 262½ lines each. Lines 1 to 21 of each constitute the vertical blanking interval, which produces the black areas between frames on a TV receiver. The other lines contain the picture signals. Each line consists of a horizontal sync pulse of maximum carrier amplitude followed by the picture signals, which are used to intensity modulate the electron beam (or beams, in color receivers) of the TV picture tube.

#### Precision measurements with 1% accuracy

The Model 191A is a precision instrument of advanced design. It is capable of measuring signal amplitudes with 1% accuracy, which is a capability not usually found in oscilloscopes of any type. It produces bright, sharp displays of fast pulses that have low repetition rates. Its frequency response and phase characteristics are carefully controlled not only within the nominal bandwidth, but also on the roll-offs or skirts of the response curves. Its differential input amplifier has high common mode rejection over an unusually wide frequency range. Transient response is also controlled to insure high-fidelity reproduction of the test signals.

The 1% accuracy of the Model 191A is achieved by means of stable, wideband amplifiers and passive filters of special design, by a mesh-type CRT with extremely constant deflection sensitivity over the entire display, by an internal graticule with a new type of flood gun illumination, and by an advanced CRT gun structure which produces a sharper spot. Brightness is 7.5 times that of most oscilloscopes, made possible by the new gun structure, which delivers more current to the screen in a sharper spot, and by the mesh structure, which makes it possible to use a 20 kV accelerating potential without losing deflection sensitivity.

The Model 191A displays VITS and video signals without

discernible jitter. This results from the use of logic circuits for positive selection of the portion of the waveform to be displayed, and from the use of a special synchronizing circuit which works well even with very noisy input signals.

Front panel controls permit easy selection of the displays that are needed in television testing. Discrete selection is provided for the parts of the video signal which contain the VITS. Five special vertical-amplifier gain-filter combinations are available for distortion tests using VITS waveforms.

For minimum size and weight and maximum reliability, the oscilloscope is all solid-state except for the CRT. It is designed to operate at temperatures between  $-20^{\circ}\text{C}$  and  $+65^{\circ}\text{C}$  and at high altitudes, so that it can be used in hot locations which are crowded with electronic equipment or in mountain-top radio relay stations.

TV waveform oscilloscopes like the Model 191A are used in the Television Operating Centers of the intercity TV network where video signals are adjusted and switched to the proper channels. Television broadcasting stations also use TV waveform oscilloscopes in their master control consoles, in video tape recorders, in adjusting both black-and-white and color cameras, and in monitoring incoming network programs.

#### Specifications

##### Vertical amplifier

**Input circuit:** loop through type.

**Terminated:** 75 ohms unbalanced; 124 ohms balanced.

**Unterminated:** 12.5 k ohms unbalanced; 25 k ohms balanced.

**Power off-on transient:** less than 5 mV.

**Transient protection:** 100 V with rise time no less than 1  $\mu\text{sec}$ .

**Common mode rejection:**  $-40$  dB from 0 to 2 MHz; decreasing at 6 dB/octave from 2 MHz to 20 MHz.

**Gain control:** selectable, fixed or variable; variable provides 140 IRE deflection for composite TV video signal from 0.2 V to over 2 V pk-pk amplitude.

**DC restorer:** On, restores to the back porch, color burst effect on the display will be less than 2 IRE; Off, restores to the average value of the input signal.

**Callibrator:** with input switch set to Cal, automatically switches vertical channel to flat filter mode, horizontal





## COMMUNICATIONS TEST EQUIPMENT



## TV WAVEFORM OSCILLOSCOPE

Precision Measurement of VITS and Video Signals  
Models 191A, 192A

sweep to 2 V mode, and applies a 120 Hz, 0.714 volt  $\pm 1\%$  signal to the vertical amplifier.

**Probe Input:** input RC, 1 megohm shunted by 25 pF; when used with X10 attenuation probe, 10 megohms shunted by 10 pF.

### Filters

**Flat:**  $+15^{\circ}\text{C}$  to  $+35^{\circ}\text{C}$ :  $\pm 0.05$  dB from 100 Hz to 1.5 MHz decreasing to  $-0.05 \pm 0.05$  dB at 4.5 MHz;  $-20^{\circ}\text{C}$  to  $+65^{\circ}\text{C}$ : decreasing to  $\pm 0.15$  dB from 100 Hz to 1.5 MHz,  $-0.1 \pm 0.2$  dB at 4.5 MHz,  $-3$  dB at 10.5 MHz, and  $-20$  dB at 20 MHz; rise time less than 50 nsec; less than 1% tilt on 60-Hz square-wave with dc restorer off.

**IRE:** standard roll-off as specified by IRE (1958 IRE Journal, page 23.S1); 20 dB down at 3.58 MHz.

**Chrominance:** band-pass filter with Q of 4 and center frequency of 3.58 MHz.

**Differential gain:** same response as Chrominance with 14 dB additional gain.

**Low pass:** more than 30 dB down at 0.500 MHz  $\pm 0.015$  MHz; 40 dB down at 1.5, 2.0, 3.0, 3.6, and 4.2 MHz; less than 2 dB down at 0.15 MHz.

### Horizontal sweep

#### Internal sweep:

2V (2.5 msec/cm):  $\pm 5\%$  for X1, X10, and X25 magnification.

2H (10  $\mu\text{sec/cm}$ ):  $\pm 3\%$  for X1 and X10;  $\pm 5\%$  for X25 magnification.

H-Line select (10  $\mu\text{sec/cm}$ ): discrete line selection for lines 16 through 21; variable line selection for all lines in the entire field.

**Free run (10  $\mu\text{sec/cm}$ ):** envelope display for video setup.

**External inputs:** two inputs to sync oscilloscope to external TV sync generators; staircase input to accept a 4-step staircase for WRGB (may be modified to accept a 3-step staircase).

#### RGB operation:

**H-RGB:** displays 3 or 4 line parade.

**V-RGB:** displays 3 or 4 field parade.

Expand mode allows 10-cm overlay display.

**Field select:** positive selection of either field; circuit is insensitive to noise pulses.

**Blanking:** decoupled to remove trace with no signal input.

**Linearity:**  $\pm 1.0\%$  of full scale.

### CRT display

**Cathode ray tube:** post-accelerator, 20 kV accelerating potential; aluminized P31 phosphor; high writing rate for viewing of sine-squared T/2 pulse.

**Graticule:** 8 cm x 10 cm parallax-free internal graticule; 140 IRE units = 7 cm; vertical and horizontal trace alignment controls; external graticules available for sine-squared pulse-and-bar, video modulation, etc.

**Bezel:** provision for external transparent plate with graticule markings; provision for illuminating both internal and external graticules.

### General

**Design:** all solid state (except for CRT) on plug-in printed circuit boards.

**Power:** 115 or 230 volts  $\pm 10\%$ , 50 to 400 Hz; approx. 70 W (no fan).

**Temperature:** operating range from  $-20^{\circ}\text{C}$  to  $+65^{\circ}\text{C}$  unless otherwise noted.

**Environmental:** meets Bell Telephone Laboratories KS-19763 environmental specifications.

**Altitude:** operates at 15,000 feet above sea level.

**Line bright output:** supplies both video and line bright gate to the associated picture monitor; line bright gate pulse is supplied in variable H-line select only.

**Accessories supplied:** two plug-in extender boards for servicing, and rack-mount kit.

**Dimensions:** 16 $\frac{3}{4}$ " wide, 5 $\frac{1}{4}$ " high, 21 $\frac{1}{2}$ " deep overall (426 x 133 x 546 mm); hardware furnished for quick conversion to 5" x 19" (127 x 483 mm) rack mount.

**Weight:** net 34 lbs (15.3 kg); shipping 39 lbs (17.6 kg).

**Price:** HP Model 191A, \$1295.

**Special order:** chassis slides and adapter kit; fixed slides, order HP Part No. 1490-0714, \$32.50; pivot slides, order HP Part No. 1490-0720, \$37.50; slide adapter kit for mounting slides on scope, order HP Part No. 1490-0721, \$20.

### Accessories available

**Camera:** HP Model 197A Camera mounts direct, adapters available for other cameras.

**Front panel cover:** cover attaches to front of scope for protection during storage or transportation, order HP Part No. 5060-0437, \$25.

**Amplifier boards:** consists of three printed circuit boards for calibration of the Model 191A vertical amplifier, order HP Part No. 00191-69501, \$160.

**External graticule kit (Model 10179A):** includes 2T-4 MHz, 2T-8 MHz, and dual graticule, \$25.

**Model 10009A probe:** probe tip is WECO Type 477B connector; input RC, 10 megohms shunted by 10 pF; when attached to Model 191A Probe Input, input signal at 0.2 V to 4 V will provide 140 IRE display; probe combined with X10 gain input amplifier in the Model 191A gives unity gain,  $\pm 10\%$ ; (other standard X10 probes may also be used with the Model 191A); price, Model 10009A, \$50.



10009A

### Model 192A TV waveform oscilloscope

The Model 192A is a half-module version of the Model 191A, and is designed for side-by-side mounting next to a half-module picture monitor. Tentative specifications for the Model 192A are identical to the Model 191A with the following exceptions:

**Dimensions:** 8 $\frac{1}{2}$ " wide, 8 $\frac{1}{4}$ " high, 19 $\frac{1}{2}$ " deep behind panel (216 x 210 x 495 mm).

**Weight:** net 31 lbs (14 kg); shipping 36 lbs (16.2 kg). No rack mount kit required.

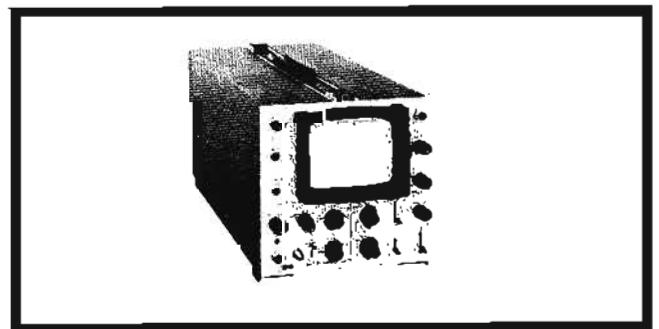

# TV WAVEFORM OSCILLOSCOPE

## Independent Relayers' Oscilloscope

### Model 193A



**COMMUNICATIONS  
TEST EQUIPMENT**

The Model 193A Television Waveform Oscilloscope is especially designed to meet both the Bell System and the independent relayers' requirements. WECO Type 477B feed-through connectors are provided on both the front and side of the oscilloscope. The vertical amplifier has five carefully defined response filters for accurate, reliable VITS and video setup measurements. Four different sweep modes permit optimum examination of fields, individual lines, and video setup.

### Specifications

#### Vertical amplifier

**Input circuit:** 75 ohms unbalanced; 124 ohms balanced; WECO Type 477B feed-through connectors.

**Input impedance:** 12.5 k ohms unbalanced; 25 k ohms balanced; 40 dB return loss to 4.5 MHz; 27 dB return loss at 20 MHz; power off-on transient less than 5 mV; 100 volts transient input protection.

**Common mode rejection:** 46 dB to 2 MHz, decreasing 6 dB per octave to 20 MHz.

**Gain control:** selectable, fixed or variable; variable provides 140 IRE deflection for input levels from 0.2 V pk-pk to 2.0 V pk-pk; fixed sets the vertical amplifier gain for 100 IRE with 0.714 volt,  $\pm 1\%$  pk-pk input signal.

**DC restorer:** On, restores to the back porch with 3 dB point at 10 Hz, color burst effect on the display will be less than 1.5 IRE unit; Off, restores to average value of the signal.

**Calibrator:** with input selector set to Cal; automatically switches vertical channel to flat filter mode, horizontal sweep to 2 H mode, and applies a 22 kHz, 0.714 V  $\pm 0.5\%$  signal to the vertical amplifier.

#### Filters

**Flat:**  $+15^{\circ}\text{C}$  to  $+35^{\circ}\text{C}$ :  $\pm 0.05$  dB from 100 Hz to 1.5 MHz, decreasing to  $-0.05 \pm 0.05$  dB at 4.5 MHz,  $-3$  dB at 10 MHz, and  $-20$  dB at 20 MHz; rise time less than 50 nsec; less than 1% tilt on 60 Hz squarewave with dc restorer off;  $0^{\circ}\text{C}$  to  $+50^{\circ}\text{C}$ : meets KS19763 specifications.

**IRE:** standard roll-off as specified by IRE (1958 IRE journal, page 23.S1).

**Chrominance:** band-pass filter with Q of 4 and center frequency of 3.58 MHz.

**Differential gain:** same response as Chrominance with 14 dB additional gain.

**Low pass:** more than 30 dB down at 0.500 MHz  $\pm 0.015$  MHz; 40 dB down at 1.5, 2.0, 3.0, 3.6, and 4.2 MHz; less than 2 dB down at 0.15 MHz.

#### Horizontal sweep

##### Internal sweep:

2 V (0.175 V/cm):  $\pm 5\%$  for X1, X5, and X25 magnification. 2 H (0.125 H/cm)  $\pm 3\%$  for X1 and X5;  $\pm 5\%$  for X25 magnification.

Free Run (0.125 H/cm): envelope display for video setup.

H-Line Select (0.125 H/cm): discrete line selection for lines 16 through 21; variable line selection for all lines in the entire field.

**Linearity:**  $\pm 5\%$  of full scale.

**Field select:** positive selection of either field; circuit is insensitive to noise pulses.

**Blanking:** decoupled to remove trace with no signal input.

#### CRT display

**Cathode ray tube:** post-accelerator, 20 kV accelerating potential; aluminized P31 phosphor; high writing rate for viewing of sine-squared T/2 pulse.

**Graticule:** 8 cm x 10 cm parallax-free internal graticule; 140 IRE units = 7 cm; vertical and horizontal trace alignment controls.

**Spot size:** (including noise) less than 1 IRE.

**Bezel:** provision for external transparent plate with graticule markings; provision for illumination of both internal and external graticules.

#### General

**Design:** all solid state (except for CRT) on plug-in printed circuit boards.

**Power:** 115 or 230 V  $\pm 10\%$ , 50 to 400 Hz, approx. 70 W (no fan).

**Temperature:** operating range  $0^{\circ}\text{C}$  to  $50^{\circ}\text{C}$ .

**Stability:** less than 1% drift in 24 hours.

**Altitude:** operates at 15,000 feet above sea level.

**Line bright output:** 1 volt  $\pm 5$  mV into 75 ohms, in variable line select mode.

**Camera:** HP Model 197A camera mounts direct, adapters for other cameras available.

**Rack mount:** rack mount kit supplied with all instruments.

**Weight:** net, 34 lbs (15.3 kg); shipping, 39 lbs (17.6 kg).

**Dimensions:** 16 $\frac{3}{4}$ " wide, 5-7/32" high, 21 $\frac{3}{8}$ " deep overall (425 x 133 x 543 mm).

**Price:** HP Model 193A, \$1350.

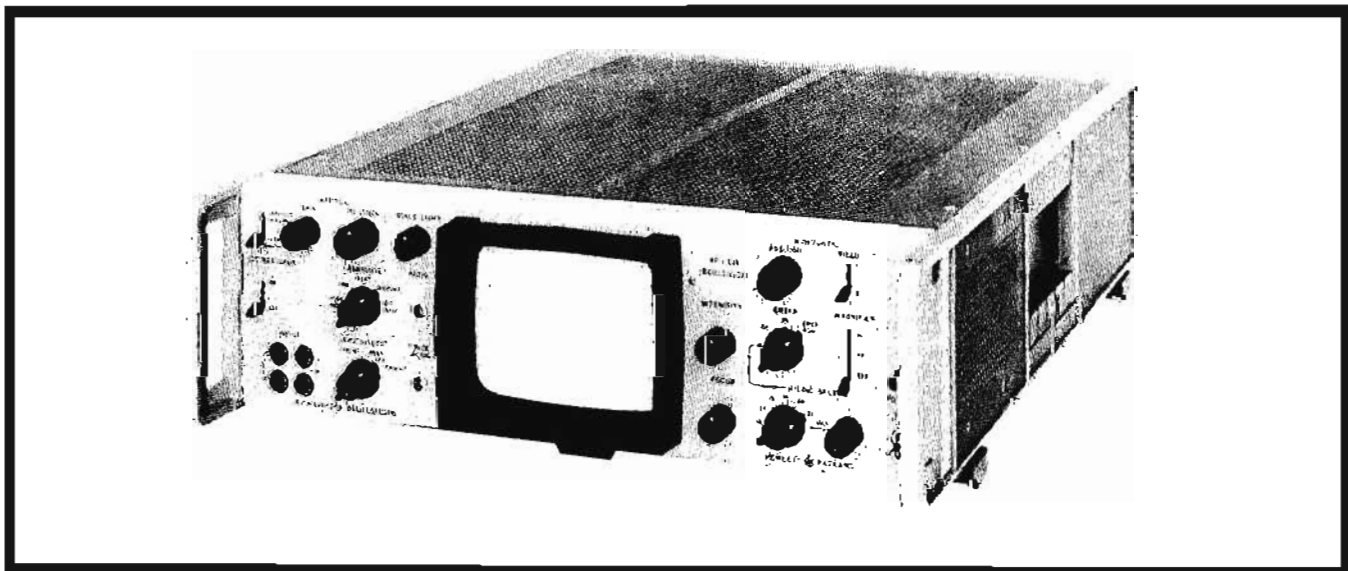

### Quick location of faults

Time domain reflectometry (TDR) speeds maintenance by locating faults such as shorts, opens, loose connectors, troublesome tap-offs, mismatched terminations, and poor cable splices. The information is presented on a cathode ray tube and discloses both the location and nature of each discontinuity. Problems of locating smashed or water damaged sections of underground cable are quickly resolved. Troubles are isolated to specific locations on the line.

### Improve picture quality

TDR reveals the quality of the transmission system by directly measuring reflection. Since reflection ghosts are an even greater annoyance to color TV viewers than to monochrome viewers, color transmission requires a higher degree of precision. CATV transmission is subject to reflection anywhere along the cable, at connectors, tapoffs, and terminations. The high sensitivity of the Model 1415A TDR plug-in can locate even the smallest ghost-causing reflection.

### Time domain reflectometry principle

TDR employs a closed loop radar method to examine cables. Cables can be easily tested in the same way a transmitted signal would see it. By sending a step voltage through the cable and measuring the reflected voltage with a high-speed sampling oscilloscope, a time profile is obtained revealing the characteristics of each point along the cable.

### Checks cables to 3000 feet

The CRT is calibrated directly in distance for air and polyethylene dielectric cables.

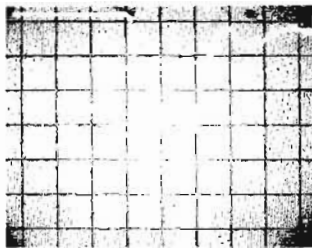

**WET CONNECTOR:** Highly magnified display of a wet connector. Multiple reflections from the faulty connector cause a reflection coefficient of  $-0.4$ .

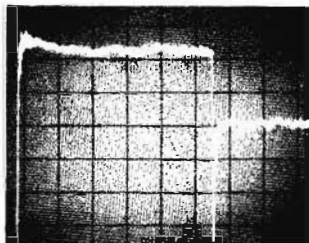

**IMPEDANCE MISMATCH:** Reflection caused by cables of different impedance. With the vertical calibrated in  $.02 \rho/cm$  and the first cable known to be  $75\Omega$ , the second cable is quickly found to be  $69\Omega$  using the TDR slide rule. From scope readout, the mismatch is located 55 ft down the  $75\Omega$  cable.

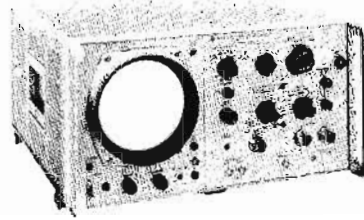

The Model 1415A can test polyethylene cable to 600 feet with 5% accuracy. The long line version, Option 14, will test to 3000 feet. A special slide rule is furnished to convert the distance scale to other dielectrics. Special techniques can double the range and pinpoint discontinuities at long distances. If both ends are accessible, measurements can be taken at each end permitting 6000 feet to be checked. Accuracy can be improved two ways. The first is to close-in on the fault by measuring at successively closer connections. The other is to compare distance to a standard cable connected in parallel. With these techniques, faults can be isolated within inches of the trouble spot. The 150 psec ( $1 \text{ psec} = 10^{-9} \text{ sec}$ ) step rise time of the Model 1415A is great enough to resolve nearby discontinuities that are less than an inch apart. The high resolution is useful to examine faulty connectors.

### Specifications, Model 1415A TDR plug-in

(Refer to page 443 for details)

Distance scale is calibrated to relate centimeters of CRT display to centimeters of transmission cable. For polyethylene line with a dielectric constant of 2.25, the CRT is calibrated to represent 200, 500, 1000, or 2000 cm line/cm display. The long line version, Option 14, will extend the range to 10000 cm line/cm display. For air line with a dielectric constant of 1, the calibration is 500, 750, 1500, or 3000 cm line/cm display. Option 14 extends calibration to 15000 cm line/cm display. Also, each calibrated display can be magnified X1 to X200 in 1, 2, 5 sequence with 5% accuracy.

**Reflectometer sensitivity:** reflection coefficients as small as 0.001 can be observed, corresponding to an SWR of

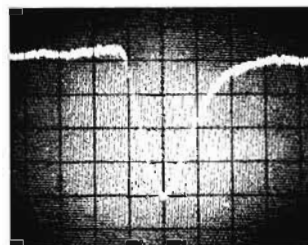

**PINCHED CABLE:** Magnified display of a pinched cable resulting from sharp radius of curvature. The calibrated CRT indicates a reflection coefficient of  $-0.04$ .

1.002; this is equivalent to a mismatch of less than 0.2 ohms in a 75-ohm line.

**Distance resolution:** system rise time is less than 150 psec and permits discontinuities separated by less than one inch (in polyethylene cable) to be resolved.

**Reflection coefficient calibration:** 0.5  $\rho/cm$  to 0.005  $\rho/cm$  in 1, 2, 5 sequence; attenuator accuracy,  $\pm 3\%$ .

**Characteristic impedance:** 50 ohms feed-through type; 75-ohm adapter available.

**Output connector:** GR Type 874.

**Maximum external signal level:** up to 1 V pk-pk may be safely applied to the Signal Out connector.

**Recorder output:** 50-ohm BNC female connectors for X and Y axis.

**Accessories furnished:** 2 GR Elbows Type 874-EL; 1 GR to Type N Adapter; 1 Type N to BNC Adapter.

**Price:** HP Model 140A, \$595; Model 1415A, \$1050; Model 1415A Option 14, \$1150.

### Rise time converters

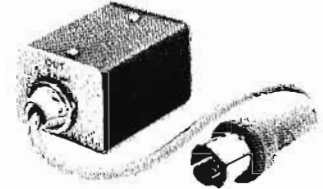

Models 10452A through 10456A Rise Time Converters slow down the step from the Model 1415A in order to eliminate reflections caused by frequencies beyond the bandwidth of interest. Rise times are 0.5, 1, 2, 5, and 10 nsec. Refer to page 443 for complete specifications.

### 75-ohm adapters



Models 10457A and 10458A Adapters convert the Model 1415A output connector to 75-ohm systems. Refer to page 443 for complete specifications.

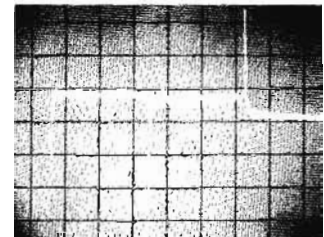

**SYSTEM PROFILE:** Reflection pattern as seen by looking down a transmission system. The pattern reveals 55 ft of  $15\Omega$  cable joined by a wet connector to a  $69\Omega$  cable. 27 ft from the connector is an inductive defect; 20 ft farther along is a capacitive defect from a pinched cable; 8 ft from the pinch is a  $67\Omega$  termination.

## COMMUNICATION EQUIPMENT

Accessories-voltmeters-oscillators-amplifiers  
11004A, 11005A and others



COMMUNICATIONS  
TEST EQUIPMENT

### 11004A line-matching transformer

The 11004A Transformer has a frequency response between 5 kHz and 600 kHz and provides fully balanced 135 or 600-ohm output from single-ended input. Maximum level +22 dBm. HP 11004A, \$60 each.

### 11005A line-matching transformer

The 11005A Transformer has a frequency response between 20 Hz and 45 kHz and provides a fully balanced 600-ohm output from single-ended input. Maximum level is +15 dBm. HP 11005A, \$80 each.

### H20-200CD wide range oscillator

This special oscillator is a standard 200CD Oscillator (refer to page 322) that has selected components to provide low-output distortion. The total distortion, including harmonic distortion and noise, is less than 0.06% (-64 dB) on the X10, X100 and X1 k ranges; 0.1% on the X1 and X10 k ranges except 5 Hz to 20 Hz and 400 kHz to 600 kHz where the distortion is 0.5%. The standard 200CD Wide Range Oscillator may be used wherever this extremely low distortion is not necessary.

### Multi-function meters

When it's important to make a variety of measurements with one instrument, select a versatile multi-function meter from Hewlett-Packard. The low cost 427A solid-state, battery-operated meter gives maximum value in general testing... while the 410C or 412A with its higher impedance is ideal for troubleshooting and calibrating magnetic tape equipment and for airline radio maintenance. Refer to the voltage/current/resistance section, pages 181 through 208.

### AC voltage measurements

Hewlett-Packard ac voltmeters offer measurements over a wide frequency range, 10 Hz to 1 GHz, at sensitivities from 1 mV to 1000 V with high-input resistances and low-input capacitances. The 400 Series can be used for magnetic tape testing, gain and loss measurements, and other applications in the broadcasting and telephone industries where a general-purpose, wide-band voltmeter is needed. The 3406A is a unique sampling voltmeter which lets you measure 1 mV to 3 V accurately, from 10 kHz to 1 GHz. Refer to pages 188 through 199.

### Solid-state amplifiers

When an amplifier is needed with low distortion, wide bandwidth and high gain, refer to the information in the amplifier section of the catalog, pages 408 to 414. The 465A Amplifier (page 409) is an ideal amplifier providing 20 dB or 40 dB gain for low level signals.

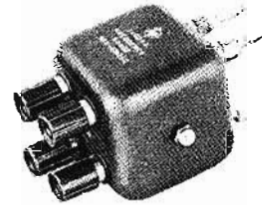

11004A

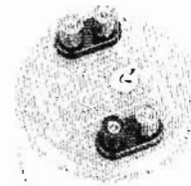

11005A



H20-200CD

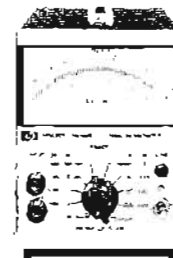

400GL

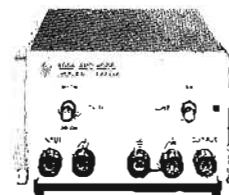

465A



# Signal Sources





A function generator is a signal generator that delivers a choice of different waveforms with frequencies adjustable over a wide range. The keynote of the modern function generator is versatility. The function generators now produce sine, triangle, square-wave and sawtooth waves with a provision to sweep or analog program frequency over at least a decade. This is useful for automatic testing systems and sweeping audio amplifiers, filters and servo systems.

HP's function generators extend from a low frequency of 0.00005 Hz (HP 203A Option 02) up to a high frequency of 100 kHz. Additional versatility is obtained with features such as dc offset, single and multiple-cycle operation, and phase lock capability.

Another modern innovation is the plug-in function generator. One may use a single main frame and several plug-ins to achieve maximum versatility at a minimum cost. Function generators now have several outputs available at the same time, each having a choice of wave shapes. By providing a square wave and a triangle wave at the same time, linearity measurements and gating may be made simultaneously.

Function generators that provide single or multiple-cycle outputs have simplified many measurements. A theoretically in-

finite on-off ratio can now be attained in pulse burst operation. To vary the starting phase of a single cycle or pulse burst and end at the same phase is also valuable. This is used in underwater research and other applications.

finite on-off ratio can now be attained in pulse burst operation. To vary the starting phase of a single cycle or pulse burst and end at the same phase is also valuable. This is used in underwater research and other applications.

The capability of the function generator to phase lock to an external source opens new possibilities for making audio measurements. By using two function generators, an adjustable phase sine output or a square or triangle wave output with adjustable delay may be obtained. One function generator may be phase locked to a harmonic of the sine wave of

another; and almost any waveform desired may be had by summing the harmonics and fundamental and adjusting the phase and amplitude of the harmonics. One can also phase lock the function generator to a frequency standard and generate all wave shapes with the frequency, accuracy and stability of the stable source.

Besides the many uses mentioned, the function generator is being used extensively in medical research projects for nerve stimulation and electroanesthesia. As medical electronic research continues to grow, the function generator will find more and more applications in this field.

### HP 3300A

The low frequency of an RC oscillator is limited. An entirely different approach is used in the 3300A Function Generator.

The main frame of this instrument delivers sine, triangular and square waves with a frequency range of 0.01 Hz to 100 kHz. The circuit outlined in Figure 1 uses a frequency control network governed internally by the frequency dial or externally through the rear-panel, frequency-control terminal.

The frequency-control voltage regulates the current source. An increase or decrease in current increases or decreases

how the slope of the triangular wave is altered as its amplitude changes, resulting in a remarkably pure sine wave.

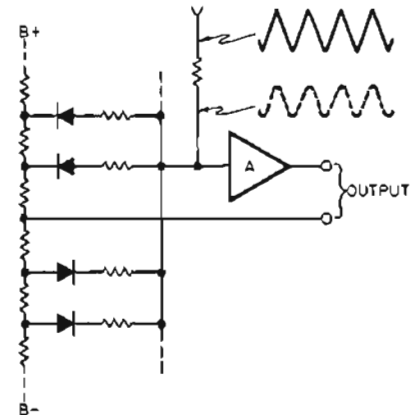

Figure 2. Non-linear shaping network

The entire oscillator circuitry is floating. The ground may be established at any desired voltage level. A special feature of this oscillator is that waveform amplitude is controlled by the reference voltages, rather than by a long-time-constant AGC circuit. As a result, there are no transients when switching between ranges or tuning to other frequencies. Another feature of the HP 3300A is two output amplifiers that provide simultaneous, individually selected outputs of any of the waveform functions.

### 3300A Plug-ins

The 3300A is made more versatile by the use of plug-ins (the 3300A must have a plug-in to operate). The HP Model 3301A Auxiliary Plug-in, 3302A Trigger/Phase Lock Plug-in and the 3304A Sweep/Offset Plug-in are now available. The HP 3301A Auxiliary Plug-in provides internal connections for the basic operation of the unit, as described in the specifications for the 3300A Function Generator.

The HP Model 3302A Trigger/Phase Lock Plug-in enables the Model 3300A Function Generator to produce either a single cycle or a burst of cycles of any of the output waveforms in response to an input trigger. The waveform bursts may also be frequency modulated.

The plug-in employs two basic operating principles. In the "Trigger" mode, it suppresses waveform generation in the main frame circuits, thus restricting the generator output to a single waveform cycle or burst of cycles. In the "Phase-Lock" mode, it contributes a correction

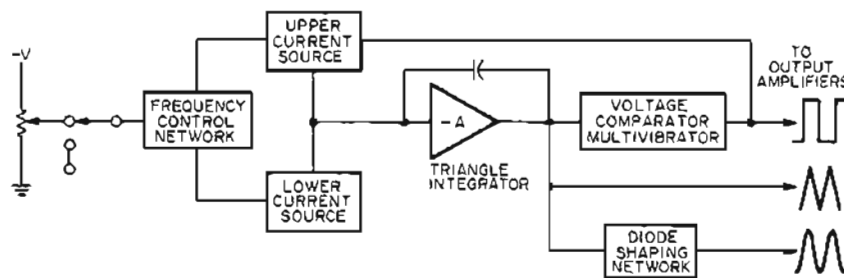

Figure 1. 3300A Function Generator.

the slope of the triangular wave. Frequency will increase if the + and - slopes are increased. The voltage comparator multivibrator changes state at predetermined limits on the positive and negative slopes of the triangular integrator's output. This change of state reverses the current into the triangular integrator, reversing the slope of the triangular output.

The circuit produces low-frequency square and triangular waves. The triangular wave is synthesized into a sine wave by a diode-resistance network. The synthesizing circuitry of Figure 2 shows

voltage to the Function Generator frequency-control circuits, phase-locking the output frequency to an external frequency source.

A front-panel meter indicates when phase lock is achieved. The phase relationship between the input and output signals can be adjusted by the front panel PHASE control over a range of  $0^\circ$  to  $180^\circ$  ( $180^\circ$  to  $360^\circ$  by using the inverted output or by reversing the input polarity switch). The phase multivibrator acts as a detector (see Figure 3) which is set by the input signal and reset by the main

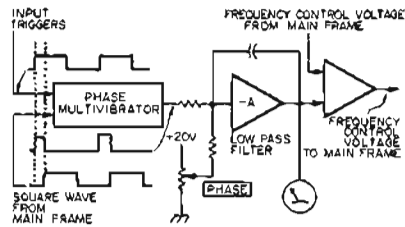

Figure 3. Block diagram of 3302A plug-in phase lock mode.

frame square wave. These pulses are filtered to derive a dc control voltage. Thus, the 3300A frequency is continuously locked to the input. The 3300A may be locked to a harmonic of the input signal.

When the MODE switch is set to "Free Run", the plug-in circuits are disabled and the function generator operates in its basic manner. With the MODE switch set to either "Single" or "Multiple", the plug-in circuits stop the generation of waveforms by clamping the output of the triangle integrator to its input at a selected phase (see Figure 4). The waveform generating circuits are released by pressing the MANUAL TRIGGER button on the plug-in or by applying a trigger pulse or gate to the plug-in input. The point in the waveform at which waveform generation starts and stops is determined by the START/STOP-PHASE control, which can be adjusted over a range of  $-90^\circ$  to  $+90^\circ$  of the waveform

The HP 3304A Sweep/Offset Plug-in

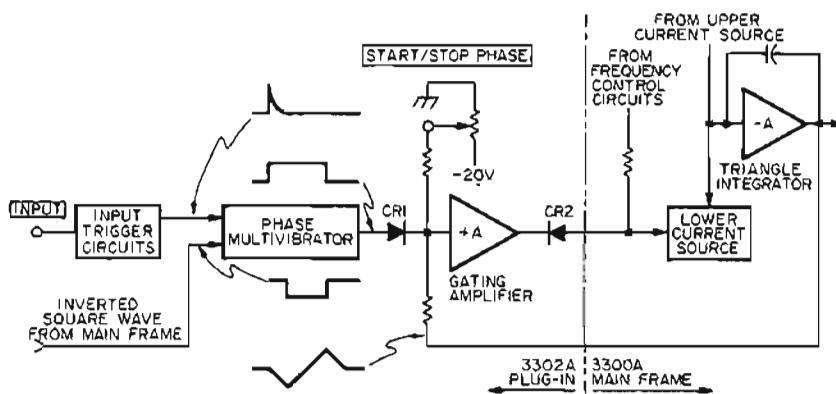

Figure 4. Block diagram of 3302A plug-in shown in single and multiple modes.

provides internal sweeping up to a decade of frequency. It generates a sawtooth waveform and delivers it to either of the 3300A output terminals, and it also provides an offset square wave and a dc offset for all of the signals generated by the 3300A and 3304A.

The offset square wave mode of operation provides a positive or negative square wave with either the top or the bottom clamped to ground or the dc offset voltage. This clamping voltage is controlled by the OFFSET SQUARE switch on the front panel.

For the sawtooth mode of operation, the 3304A uses a sawtooth generator, a RANGE switch, a FREQUENCY control and a  $\pm$  SAWTOOTH selector switch. Figure 5 shows a simplified block diagram of the sawtooth generator.

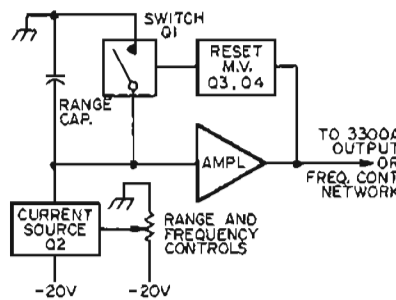

Figure 5. Simplified sawtooth generator.

A capacitor is charged from a constant current source, Q2, which is controlled by a voltage, adjusted by the frequency control. Two signals, of different polarity selected by a  $\pm$  SELECTOR switch, may be connected to the 3300A output amplifier.

For the internal sweeping of the 3300A output functions, the 3304A uses the negative sawtooth output, a start-frequency emitter follower, a summing amplifier and a SWEEP WIDTH control. The start frequency is set by the 3300A FREQUENCY dial and RANGE selector (it may be by remote control). The summing amplifier adds the start frequency control voltage and the negative sawtooth ramp. The negative voltage

trolled by the 3304A SWEEP WIDTH control. The rate of the sweep is controlled by the 3304A sawtooth frequency.

For the dc offset which is applied to all output functions of the 3300A, the 3304A applies a dc voltage between output ground and circuit ground (see Figure 6, 3304A dc offset).

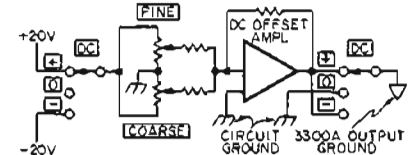

Figure 6. 3304A dc offset.

Because of its versatility, the HP 3300A with its various plug-ins may be used for all of the applications listed in the first few paragraphs of this section.

## HP 203A

Another HP function generator is the 203A Variable Phase Function Generator. This instrument has a sine wave and square wave output with a second channel that can be phase-shifted continuously through a full  $360^\circ$  range.

Although this function generator is intended primarily for low-frequency work, it has a frequency range extending from 60 kHz down to 0.005 Hz or, with options, down to as low as 0.00005 Hz (5 hours for 1 Hz). All four output signals are supplied simultaneously and all have individual 40 dB attenuators.

The HP Model 203A Function Generator is well suited as a source of sine waves for critical tests of audio, as well as sub-audio, equipment.

The 203A uses beat frequencies combined with divider techniques. This allows the phase-shifting device to be placed in a fixed frequency channel.

The highest frequency range (5 to 60 kHz) is obtained by dividing down a crystal oscillator frequency by a factor of 9. This fixed-frequency output (FFO) is heterodyned with the variable frequency oscillator (VFO) signal in a double-balanced mixer to derive the output signal. The lower frequency ranges are derived by successive decade frequency dividers and mixers.

The square-wave output is derived by applying the output sine wave to a clipping amplifier and improving the rise time of the resulting square-wave in a dc-coupled regenerative circuit.

The phase-shifted outputs are obtained by a goniometer with two stator field windings at right angles to each other and a pick-up coil that can rotate within the stator fields. The phase of the signal induced in the pick-up coil depends on the coil's angular position.



# VARIABLE-PHASE GENERATOR

Sine- and square-waves 0.00005 Hz to 60 kHz  
Model 203A



## SIGNAL SOURCES

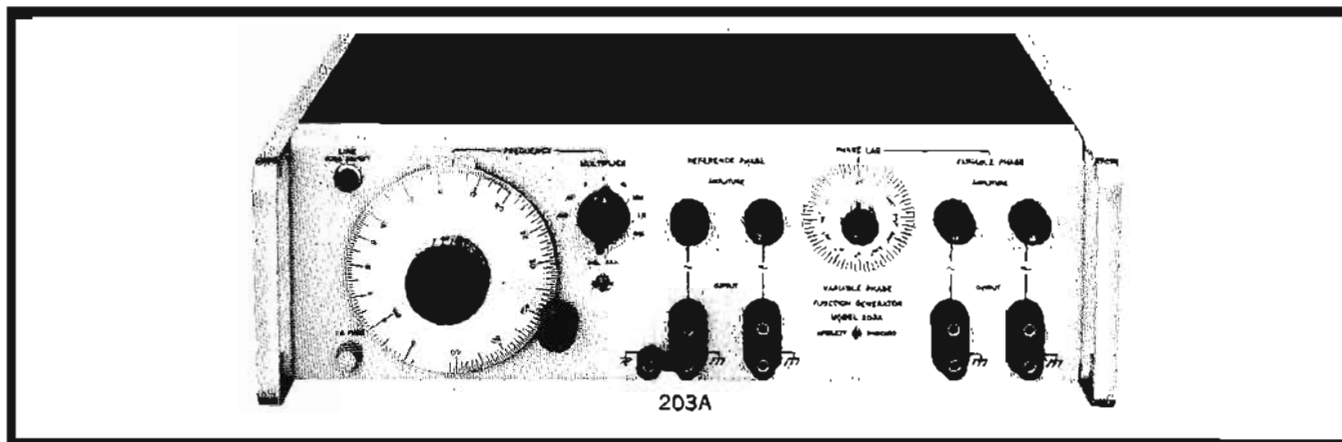

The solid-state HP Model 203A Low-Frequency Function Generator provides two transient-free low-distortion square and sinusoidal test signals particularly useful for a wide variety of low-frequency applications. Field and laboratory testing of servo, geophysical, medical and high-quality audio equipment become practical when using the 203A.

The 203A frequency range of 0.005 Hz to 60 kHz is covered in 7 overlapping bands (2 additional ranges available on special order, offering frequency range to 0.00005 Hz). Accurate  $\pm 1\%$  frequency setting is provided by 180 dial divisions. A vernier drive allows precise adjustment.

### 30 volt output

The 203A provides a maximum output voltage of 30 V peak-to-peak for all waveforms. The sinusoidal signals have a distortion that is less than 0.06% and provide virtually transient-free outputs when frequency and operating conditions are varied rapidly. The four output circuits of the 203A have individual 40 dB continuously variable attenuators.

Outputs consist of a reference sine and square wave, and a variable-phase sine and square wave. The two sine- and square-wave outputs are electrically identical except that one sine- and square-wave output contains a 0-to-360 degree phase-shifter. These four signals (two reference phase and two variable phase) are available simultaneously from the 203A. The output system is floating with respect to ground and may be used to supply an output voltage with either terminal grounded, or may be floated up to 500 volts dc above chassis ground. The output impedance is 600 ohms for all outputs.

### Special features

A front-panel calibration provision permits the user to easily calibrate the oscillator frequency to the environment in which the instrument is used. The HP 203A features a unique method of mixing, filtering and dividing the frequency to maintain an exact decade relationship. Interchangeable decade modules provide greater reliability and ease of servicing.

### Specifications, 203A

**Frequency range:** 0.005 Hz to 60 kHz in seven decade ranges.\*

**Dial accuracy:**  $\pm 1\%$  of reading.

**Frequency stability:** within  $\pm 1\%$ , including warmup drift and line voltage variations of  $\pm 10\%$  (typical short term 1 part in  $10^4$ ).

**Output waveforms:** sine and square waves are available simultaneously; all outputs have common chassis terminal.

**Reference phase:** sine wave, 0 to 30 V peak-to-peak; square wave, 0 to 30 V peak-to-peak.

**Variable phase:** sine wave, 0 to 30 V peak-to-peak; square wave, 0 to 30 V peak-to-peak; continuously variable, 0 to  $\pm 360^\circ$ ; phase dial accuracy,  $\pm 5^\circ$  sine wave,  $\pm 10^\circ$  square wave.

**Output impedance:** 600 ohms.

**Output power:** 5 volts into 600 ohms (40 mW); 40 dB continuously variable attenuation on all outputs.

**Distortion:** total harmonic distortion hum and noise  $> 64$  dB below fundamental ( $< 0.06\%$ ), at full output.

**Output system:** direct-coupled output is isolated from ground and may be operated floating up to 500 Vdc.

**Frequency response:**  $\pm 1\%$  referenced to 1 kHz.

**Square wave response:** rise and fall time,  $< 200$  ns; overshoot,  $< 5\%$  at full output.

**Power:** 115 or 230 volts  $\pm 10\%$ , 50 to 1000 Hz, approximately 25 W.

**Dimensions:** cabinet:  $5\frac{1}{4}$ " high,  $16\frac{3}{4}$ " wide,  $11\frac{1}{4}$ " deep (133 x 425 x 286 mm); rack mount kit (203A-00203) furnished with instrument.

**Weight:** net 20 lbs (9,17 kg); shipping 28 lbs (12,5 kg).

**Price:** HP 203A, \$1200; Option 01, add \$40; Option 02, add \$80.

\*Two lower ranges of 0.0005 Hz (Option 01) and 0.00005 Hz (Option 02) are available on special order.



## LOW-FREQUENCY GENERATOR

0.008 Hz to 12 kHz; sine-square-triangular waves  
Model 202A

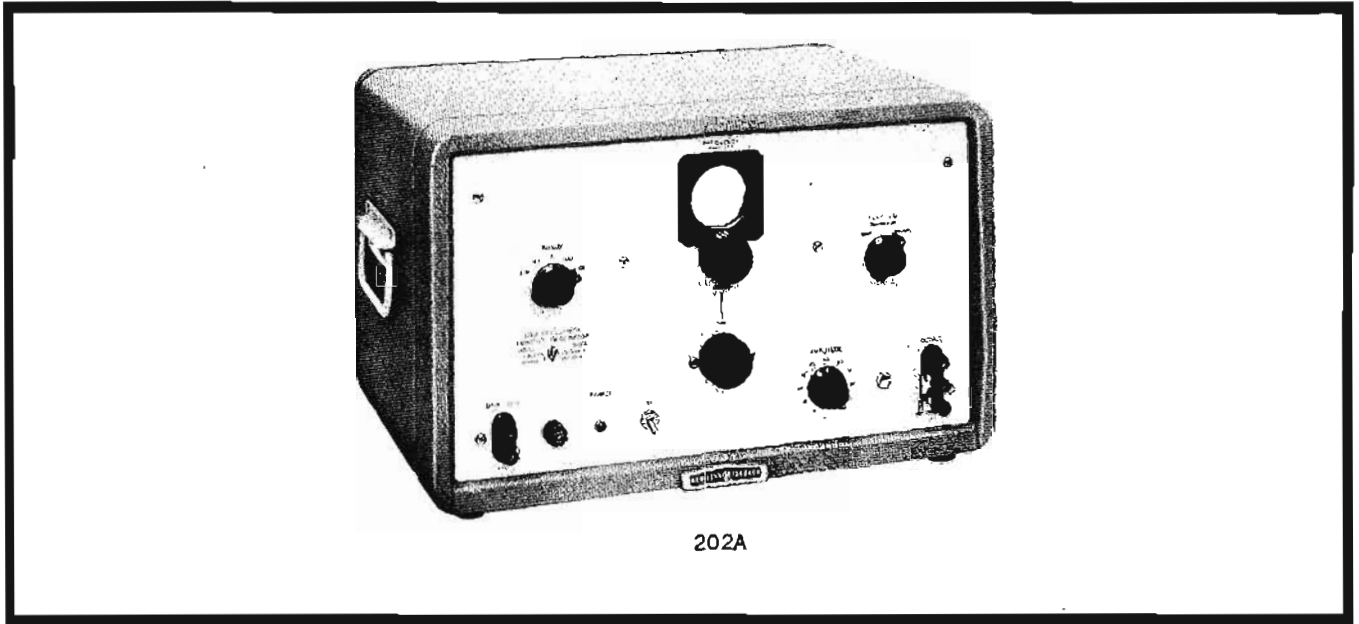

The HP 202A Low-Frequency Function Generator is a compact, convenient, multi-purpose source of transient-free test voltages. It is particularly useful for testing servo, geophysical and medical equipment and for the electrical simulation of mechanical phenomena.

Output frequency is continuously variable from 0.008 Hz to 1200 Hz in 5 bands. Model 202A offers exceptional stability and distortion of less than 1% over most of the band. Any of three desired waveforms—sine, square or triangular—may be selected by a front-panel switch. Output is high—30 volts peak-to-peak—for all three waveforms and is essentially constant over the entire frequency range.

The HP 202A differs from conventional low-frequency oscillators in that the sine wave is electronically synthesized. A controlled bi-stable circuit generates a rectangular wave. This wave is passed through a special integrator, providing a true triangular wave.

The triangular wave then enters a shaping circuit designed exclusively for this equipment. In this circuit, 12 crystal diodes modify or "shape" the wave and provide a sine wave. This sine wave has a distortion of less than 1%, and the synthesizing circuit provides virtually transient-free output even when frequency and operating conditions are rapidly varied. It is not necessary to wait long periods for the circuits to stabilize, as is the case with conventional low-frequency oscillators. The circuit inherently maintains constant amplitude over the entire frequency range.

The output system of the 202A is fully floating with respect to ground and may be used to supply a balanced voltage or an output voltage with either output terminal grounded. The equipment will deliver 10 volts rms into a load of 4000 ohms or greater. Internal impedance is only 40 ohms. There are no coupling capacitors in the output system, and a high degree of dc balance is achieved.

### Specifications

- Frequency range:** 0.008 to 1200 Hz in five decade ranges.
- Dial accuracy:** 2% from 1.2 to 12; 3% from 0.8 to 1.2.
- Frequency stability:** within 1%, with line voltage variations of  $\pm 10\%$ .
- Output waveforms:** sinusoidal, square and triangular.
- Maximum output voltage:** 30 volts peak-to-peak across rated load (4000 ohms) for all three waveforms (10.6 volts rms for sine wave).
- Internal impedance:** approx. 40 ohms over entire range.
- Sine wave distortion:** 1% on X0.01, X0.1, X1, and X10 ranges; 2% on X100 range.
- Output system:** output is isolated from ground and may be operated balanced or with either side grounded; output system is direct-coupled; dc level of output remains stable over long periods of time and can be adjusted to zero by a front-panel control.
- Frequency response:**  $\pm 0.2$  dB.
- Hum level:** 0.05% of output.
- Sync pulse:** 10 volts peak negative, less than 5  $\mu$ s duration; sync pulse occurs at crest of sine and triangular wave output.
- Power:** 115 or 230 volts  $\pm 10\%$ , 50 to 1000 Hz, approximately 150 watts.
- Dimensions:** cabinet: 20 $\frac{3}{4}$ " wide, 12 $\frac{3}{4}$ " high, 14 $\frac{5}{8}$ " deep (528 x 324 x 372 mm); rack mount: 19" wide, 10-15 $\frac{32}{32}$ " high, 13" deep (483 x 266 x 330 mm).
- Weight:** net 42 lbs (18,9 kg), shipping 52 lbs (23,4 kg) (cabinet); net 37 lbs (16,6 kg), shipping 45 lbs (20,3 kg) (rack mount).
- Accessories available:** 11000A Cable Assembly, \$4.50; 11001A Cable Assembly, \$5.50.
- Price:** HP 202A, \$550 (cabinet); HP 202AR, \$535 (rack mount).

# FUNCTION GENERATOR

Plug-ins, multiple outputs, versatility  
Model 3300A & plug-ins



## SIGNAL SOURCES

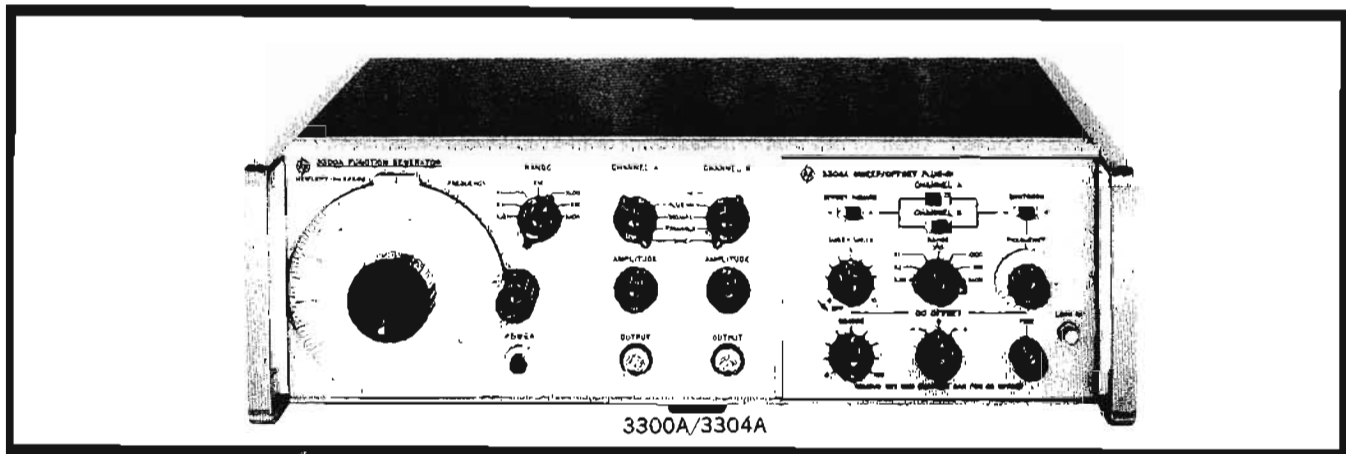

### Advantages with plug-ins

- Sine, square, triangular, sawtooth waves (3304A)
- Frequency from 0.01 Hz to 100 kHz
- Flat frequency response; distortion less than 1%
- Two simultaneous outputs; electronic frequency control
- Balanced, single-ended, floating outputs
- Single-cycle or multi-cycle bursts; phase lock capability
- Sweep frequencies for more than decade
- DC offset for all wave shapes; offset square wave

Maximum versatility and usefulness with plug-ins and multiple outputs set the HP 3300A Function Generator apart from other function generators. Any two of three waveforms — sine, square or triangular — may be selected by a front-panel switch, covering all frequencies from 0.01 Hz to 100 kHz, continuously adjustable in seven decade ranges. This solid-state, multi-purpose source provides simultaneous signals of any two waveforms, with constant amplitude over the entire frequency range.

Plug-ins, which insert directly into the front panel, include the HP 3301A Auxiliary Plug-in, HP 3302A Trigger Phase Lock Plug-in and HP 3304A Sweep/Offset Plug-in. The 3302A provides single- and multiple-cycle operation with variable start/stop phase. A phase lock loop in the 3302A permits synchronizing the 3300A with an external signal and provides variable phase control. The HP 3304A Sweep/Offset Plug-in provides internal sweeping, sawtooth waves, offset square waves and a dc offset for all four output waveforms. The 3300A Function Generator with plug-in versatility provides a compact, convenient multi-purpose source of test waveforms useful for testing servo, geophysical and medical equipment, and for the electrical simulation of mechanical phenomena. Refer to the introduction to function generators, page 303, for further applications.

### Electronic frequency control

The frequency of the HP 3300A can be controlled by either the front-panel frequency dial or an external voltage applied to a rear-terminal connector. This feature is useful for sweeping filters, amplifiers and other frequency-depend-

ent devices and for externally programming frequencies for production testing. An input voltage of +0.3 to -10 volts will linearly control the frequency over approximately a 50:1 range. Frequency can be changed remotely over a decade on any one range in approximately 1  $\mu$ s.

### Output system

The output system of the 3300A is dc coupled and fully floating with respect to power line ground. An internal shield reduces radiated interference and provides common mode rejection with floating output. Separate connectors on the rear panel provide terminals for circuit ground, shield ground and power line ground. The operator may connect a dc supply to the rear terminals and obtain a dc offset voltage on the output up to  $\pm 25$  volts between circuit ground and output ground and  $\pm 250$  volts between output ground and power-line ground or output ground and shield.

The 3300A may be used to supply a balanced output, using both output amplifiers. Each output amplifier will deliver 35 volts p-p into an open circuit.

### 3301A Auxiliary Plug-in

The HP 3301A Auxiliary Plug-in provides internal connections for basic unit operation.

### 3302A Trigger/Phase Lock Plug-in

The 3302A is designed to provide single-cycle, multiple-cycle and phase-lock operation. The instrument can be triggered over the entire frequency range, either manually or by applying an external voltage.

### Single-cycle operation

In single-cycle operation, one cycle of any function can be obtained by pushing the manual trigger or applying a signal to the external trigger input. The output starts and stops at the same phase, which is adjustable from -90 degrees to +90 degrees with the front-panel start/stop phase control. The input trigger circuit is dc coupled and may be actuated with either polarity of applied pulses.

In the single-cycle mode, a variable phase output can be



## FUNCTION GENERATOR

Variable phase, phase lock, dc sweeper, offset  
Models 3302A, 3304A

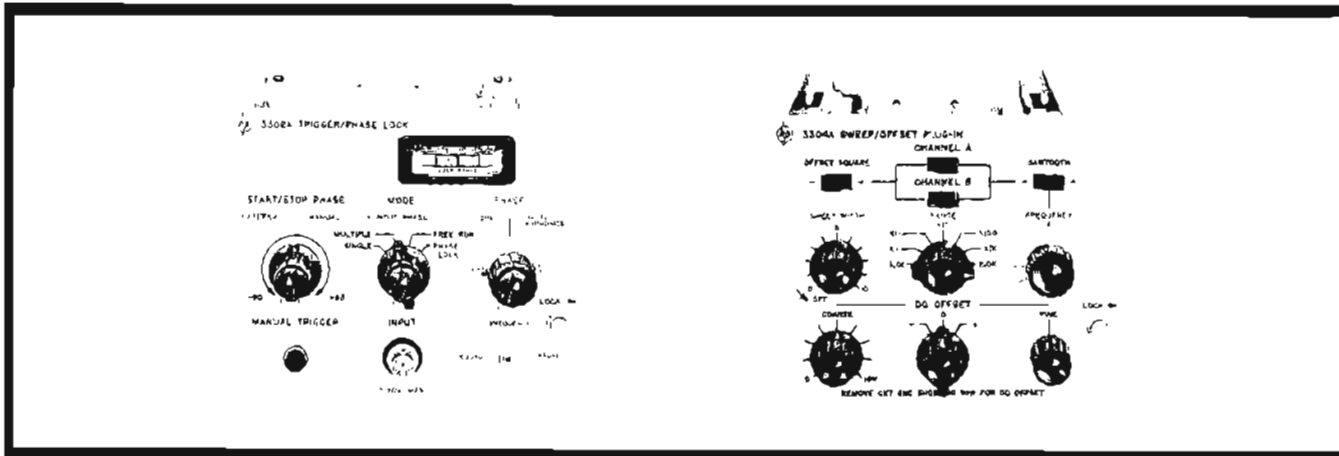

obtained by triggering with an external sine wave tuned to the same frequency as the 3300A, using the input phase switch and the start/stop phase control. This is particularly useful at frequencies below 10 Hz where a phase lock system is not practical.

In addition, when an external trigger is applied, the instrument can be used as a low-frequency pulse generator using the square wave output. The pulse repetition rate is determined by the repetition rate of the applied trigger voltage; the pulse width is controlled by the 3300A frequency control, and the pulse delay is adjustable using the start/stop phase control. Pulses can also be obtained by using the manual trigger.

### Multiple-cycle operation

In the multiple-cycle mode of operation, any number of complete cycles of any function can be obtained by pushing the manual trigger to start and stop or by applying an external gate voltage. The output signal will start and stop at the same phase, adjustable from  $-90$  degrees to  $+90$  degrees with the start/stop phase control. The 3302A is useful for generating waveform bursts or pulse trains for transient response and coding system measurements.

### Phase-lock operation

The 3300A may be phase-locked to any periodic signal with a frequency from 10 Hz to 100 kHz. A meter, located on the plug-in front panel, indicates when phase lock is achieved. The phase shift between the input signal and the 3300A can be adjusted over a 360 degree range using the phase control and the input phase switch. This feature is particularly useful for generating a variable phase output at frequencies greater than 10 Hz.

The instrument also may be phase-locked to a harmonic of an externally applied signal, making it useful for synthesis of complex waveforms. In addition, the 3300A may be phase-locked to an external source to obtain sine, triangle and square wave outputs with frequency characteristics of the externally applied signal.

### 3304A sweep/offset plug-in

The HP 3304A Sweep/Offset Plug-in provides internal sweeping, dc offset, sawtooth waves and offset square waves (refer to 3304A front panel). Up to  $\pm 16$  volts of dc offset is available for all signals generated in the main frame and plug-in.

The offset square wave provides added versatility by clamping either the top or the bottom of the waveform to the dc offset voltage or ground potential.

A dc voltage selected by the 3304A OFFSET POLARITY switch and COARSE and FINE controls is inserted between circuit ground and the 3300A output ground. In the offset square wave mode of operation, the square wave from the 3300A is isolated and applied to a bias voltage selected by the OFFSET SQUARE switch. This develops the clamping voltage for the 3300A output. The dc offset features of the 3304A plug-in fulfill the needed requirements for a signal balance above or below ground potential when driving or stimulating an electro-mechanical or medical system.

The sawtooth waveform is generated in the 3304A by charging a capacitor from a constant current source. The frequency is controlled by the RANGE and FREQUENCY controls in the plug-in. Two sawtooth waves are developed simultaneously of different polarities, and either may be selected and applied to the 3300A output terminals. This sawtooth output can be used for sweeping or driving systems where a single direction sweep is desired. It is also useful as a sweep output when internally sweeping the main frame.

For internal sweeping of the output functions of the 3300A in any one range, the 3304A uses the negative sawtooth output of the sawtooth generator. The start frequency is selected by the 3300A frequency dial and range switch, or it may be selected by remote control. A summing amplifier adds this start frequency voltage to the changing sawtooth voltage, sweeping up to a decade of frequencies.

## Specifications, 3300A Function Generator

### Available plug-in units\*:

- Model 3301A Auxiliary Plug-in
- Model 3302A Trigger Plug-in
- Model 3304A Sweep/Offset Plug-in

**Output waveforms:** sinusoidal, square and triangular selected by panel switch (any two outputs available simultaneously).

**Frequency range:** 0.01 Hz to 100 kHz in 7 decade ranges.

**Frequency response:**  $\pm 1\%$ , 0.01 Hz to 10 kHz;  $\pm 3\%$ , 10 kHz to 100 kHz.

**Dial accuracy:**  $\pm 1\%$  of maximum dial setting (1 minor division) 0.01 Hz to 10 kHz;  $\pm 2\%$  of maximum dial setting (2 minor divisions) 10 kHz to 100 kHz. T.C. 0.1%/°C.

**Maximum output per channel:**  $> 35$  V p-p open circuit;  $> 15$  V p-p into 600 $\Omega$ ;  $> 2$  V p-p into 50 $\Omega$ .

**Sine wave distortion:**  $< 1\%$ , 0.01 Hz to 10 kHz;  $< 3\%$ , 10 kHz to 100 kHz.

**Output attenuators (both channels):** 40 dB range.

**Square wave response:**  $< 250$  ns rise and fall time on all ranges;  $< 1\%$  sag,  $< 5\%$  overshoot at full output;  $< 1\%$  symmetry error.

**Triangle linearity error:**  $< 1\%$ , 0.01 Hz to 10 kHz,  $< 2\%$ , 10 kHz to 100 kHz  $< 1\%$  symmetry error.

**Sync pulse output:**  $> 10$  V p-p, open circuit  $< 5$   $\mu$ s duration. Sync pulse occurs at crest of sine and triangular wave output.

**Output impedance (both channels):** 600 ohms nominal.

**DC stability:** drift:  $< \pm 0.25\%$  of p-p amplitude over a period of 24 hours (after 30 minute warmup).

**Remote frequency control:** 0 to  $-10$  volts will linearly change frequency  $> 1$  decade within a single range. Frequency resettability with respect to voltage  $\pm 1\%$  of maximum frequency on range selected.

**Power:** 115 or 230 V  $\pm 10\%$ , 50 to 1000 Hz, approx. 50 W.

**Dimensions:** 16" wide, 5" high, 11" deep (406 x 127 x 279 mm) standard HP full module.

**Weight:** net 20 lbs (9 kg); shipping 23 lbs (10.4 kg).

**Price:** HP 3300A, \$625.

## Specifications, 3304A, Plug-in

**Modes of operation:** single cycle, multiple cycle, phase lock, free run.

### Trigger requirements

**Single cycle:** manual or external, DC coupled. Requires at least 0.5 volt to trigger externally. May be triggered with positive or negative input voltage ( $\pm 20$  V peak max.).

**Multiple cycle:** manual or external start/stop. DC coupled. Requires at least 0.5 volt to start, 0 volts to stop. May be triggered with either positive or negative input voltage ( $\pm 20$  V peak max.).

**Phase lock:** (10 Hz to 100 kHz) dc coupled. Requires 0.5 volt p-p to lock, 10 volts p-p for specified accuracy

with sine wave input. The HP 3302A will lock on a fundamental or harmonic of the input signal.

**Phase dial accuracy:**  $\pm 10^\circ$  from 10 Hz to 10 kHz.  $\pm 20^\circ$  from 10 kHz to 100 kHz (fundamental only).

**Introduced distortion:**  $< 1\%$ , 10 Hz to 10 kHz;  $< 3\%$ , 10 kHz to 100 kHz (fundamental only).

**Weight:** net 3 lbs (1.4 kg); shipping 5 lbs (2.5 kg).

**Dimensions:** 6-1/16" wide, 4 3/4" high, 10 1/4" deep (153.9 x 120.7 x 260.4 mm).

**Price:** HP 3302A, \$190.

## Specifications, 3302A Plug-in

### DC offset

**Voltage range:** adjustable 0 to  $\pm 16$  volts open circuit and a  $\pm 1$  volt vernier control.

**DC stability:**  $\pm 50$  mV over a 24-hour period (after 30 minute warmup).

### Offset square wave

**Output polarity:** positive or negative, from dc offset voltage or ground potential.

**Amplitude:**  $> 15$  volts p-p open circuit. Continuously adjustable with 3300A amplitude control. Attenuator range,  $> 40$  dB.

**Rise time:**  $< 400$  ns.

**Overshoot:**  $< 5\%$  at full output.

**Sag:**  $< 1\%$ .

### Sawtooth waveform

**Frequency range:** 0.01 Hz to 100 kHz, continuously adjustable over seven decade ranges.

**Dial accuracy:**  $< \pm 10\%$  full scale; 0.01 Hz to 1 Hz;  $< \pm 5\%$  full scale, 1 Hz to 100 kHz.

**Amplitude:**  $> 15$  volts p-p, open circuit. Continuously adjustable with 3300A amplitude control.

**Frequency response:**  $< 2\%$ , 0.01 Hz to 10 kHz;  $< 5\%$ , 10 kHz to 100 kHz.

**Output polarity:** positive or negative, from dc offset voltage or ground potential.

**Linearity:**  $< 1\%$ , 0.01 Hz to 10 kHz, overshoot  $< 5\%$ ;  $< 2\%$ , 10 kHz to 100 kHz, overshoot  $< 5\%$ .

**Flyback time:**  $< 5\% + 250$  ns.

### Internal sweep

**Controls:** start frequency set by 3300A frequency dial; sweep range set by sweepwidth control on plug-in.

**Sweep rate:** determined by sawtooth frequency setting.

**Sweep width:** adjustable from 0 to at least one decade on any one range.

### General

**Weight:** net 4 lbs (1.8 kg); shipping 6 lbs (2.7 kg).

**Dimensions:** 6-1/16" wide, 4 3/4" high, 10 1/4" deep (153.9 x 120.7 x 260.4 mm).

**Price:** HP 3304A, \$210.

\*3300A requires a plug-in to operate.



Pulse and square wave generators most often are used with an oscilloscope as the measuring device. Waveform shapes as seen by the oscilloscope, either at the output or at pertinent points within a system under test, provide both qualitative and quantitative evaluations of system or device performance.

### Square waves or pulses

The fundamental difference between pulse and square wave generators concerns the signal duty cycle. Square wave generators have equal "on" and "off" periods, this equality being retained as the repetition frequency is varied. The duration of a pulse generator "on" period, on the other hand, is independent of pulse repetition rate. The duty cycle of a pulse generator can be made quite low so that these instruments are generally able to supply more power during the "on" period than square wave generators. The HP Model 214A, for instance, supplies up to 200 watts in its output pulse.

Short pulses reduce power dissipation in the component or system under test. For example, measurements of transistor gain are made with pulses short enough to prevent junction heating and the consequent effect of heat on transistor gain.

Square wave generators are used where the low-frequency characteristics of a system are important, such as in the testing of audio systems. Square waves also are preferable to short pulses if the transient response of a system requires some time to settle down.

### Pulse generators

In the selection of a pulse generator, the quality of the output pulse is of primary importance. High-quality test

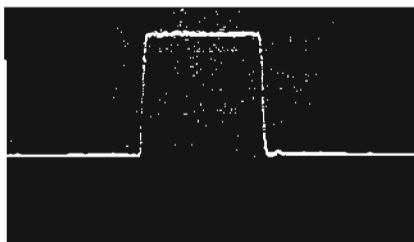

Figure 1. Carefully controlled pulse shapes insure accurate measurements.

pulses insure that degradation of the displayed pulse may be attributed to the test circuit alone.

The pertinent characteristics of a test pulse, shown in Figure 2, are controlled and specified accurately in HP pulse generators. Rise and fall times should be significantly faster than the circuits or systems to be tested. Any overshoot,

ringing and sag in the test pulse should be known, so as not to be confused with similar phenomena caused by the test circuit.

The range of pulse width control should be broad enough to fully explore the range of operation of a circuit. Narrow pulse widths are useful in determining the minimum trigger energy required by some circuits.

Maximum pulse amplitude is of prime concern if appreciable input power is required by the tested circuit, such as a magnetic core memory. At the same time, the attenuation range should be broad enough to prevent overdriving the test circuits, as well as to simulate actual circuit operating conditions.

The range of pulse repetition rates is of concern if the tested circuits can operate only within a certain range of pulse rates, or if a variation in the rate is needed. The HP Model 216A is capable of rep rates to 100 MHz for testing fast circuits and has a pulse burst feature which allows trains of pulses rather than a continuous output to be used to check systems more thoroughly.

### Triggering

The trigger requirements for synchronizing a pulse generator should be evaluated in light of the triggers available in anticipated measurement set-ups. Most Hewlett-Packard pulse generators have versatile trigger circuits similar to oscilloscopes. These circuits synchronize on most waveforms of more than 1 V amplitude.

Hewlett-Packard pulse generators also supply fast rise output triggers for operation of external equipment. The output triggers may be timed to occur either before or after the main output pulse.

### Source impedance

Generator source impedance is an important consideration in fast pulse systems. This is because a generator which has a source impedance matched to the connecting cable will absorb reflections resulting from impedance mismatches in the external system. Without this match, reflections would be re-reflected by the generator, resulting in spurious pulses or perturbations on the main pulse.

DC coupling of the output circuit is necessary when retention of dc bias levels in the test circuit is desired in spite of variations in pulse width, pulse amplitude or repetition rate.

### Applications of pulse and square wave generators

Pulse generators with fast rise times are widely used in the development of

digital circuitry. Teamed with a suitably fast oscilloscope, these generators enable evaluation of transistor and diode switching times.

Pulse generators are used as modulators for klystrons and other rf sources to obtain high peak power while maintaining low average power.

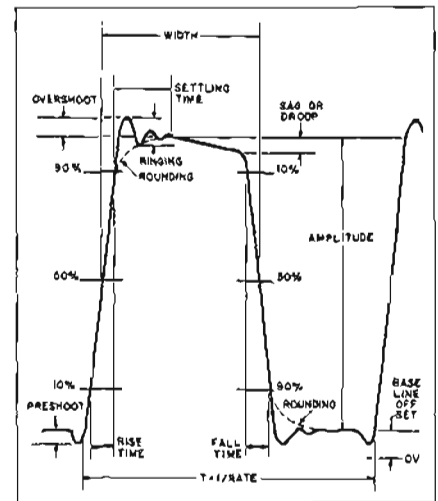

Figure 2. Test pulse description in terms of primary characteristics.

Pulse generators also are used for impulse testing. A very short pulse is rich in harmonic frequency components, so that impulse testing amounts to simultaneous frequency response testing of components or systems.

A relatively new application of fast pulse instruments is the testing of transmission lines, discussed in more detail on page 442. Very fast pulse generators (HP Models 213B, 215A and 1105A/1106A) used with fast oscilloscopes (HP Models 1430A or 1432A) also can measure the stray inductances and capacitances of components.

Tests of linear systems with pulse or square wave generators and oscilloscopes are dynamic tests which quickly analyze system performance. Because of the Fourier transform relationships between the transient response of a system and its frequency and phase characteristics, overall system response can be evaluated by observing the pulse response on an oscilloscope.

Hewlett-Packard designs pulse generators with the fast rise times, matched source impedance, flexible pulse width and amplitude control, and versatile triggering capabilities required by a wide range of measurements. Particular attention has been paid to the quality of the output pulse, with all aspects of pulse shape carefully controlled and specified in detail.

# SQUARE WAVE AND PULSE GENERATORS

Models 211B, 211A, 1105A/1106A, 213B



## SIGNAL SOURCES

### Model 211B Square Wave Generator

The Model 211B is a compact, fully transistorized Square Wave Generator designed for general purpose laboratory and production line applications. It provides frequency coverage from 1 Hz to 10 MHz in seven decade ranges with a linearly calibrated dial for continuous adjustment on all positions. A constant repetition frequency is maintained as the symmetry control varies the "on" time from 25 - 75% of the period.

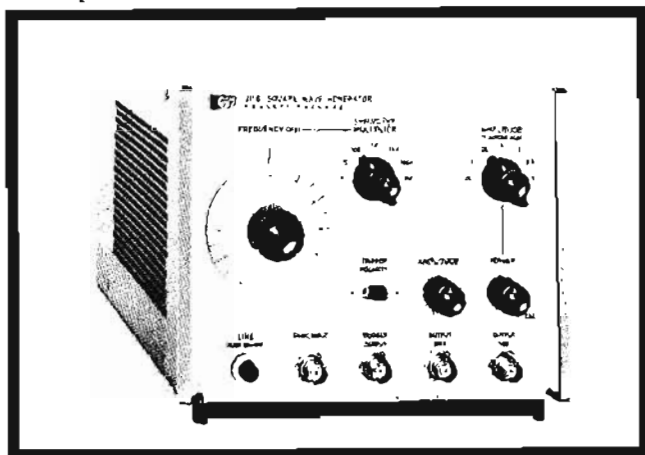

#### Specifications, Model 211B

- Symmetry control:** variable from 25 - 75% duty cycle.  
**Polarity:** negative.  
**Phase difference:** 180° between 50 and 600 ohm outputs at 50% duty cycle.  
**Source RC:** 50 ohms  $\pm 3\%$  shunted by approximately 15 pF.  
**Pulse shape:** (measured at 5 V into 50 ohms).  
**Rise and fall times:** less than 5 nsec.  
**Overshoot and ringing:** less than 5% peak of pulse amplitude.  
**Preshoot:** less than 5%.  
**Corner rounding:** occurs no sooner than 95% of full pulse amplitude.  
**Amplitude:**  
**Peak voltage:** 5 V into 50 ohms, 10 V into an open circuit; output circuit protected, cannot be damaged by shorting.  
**Attenuator:** 0.05 to 5 V, in a 1, 2.5, 5 sequence.  
**Vernier:** provides continuous adjustment between ranges; minimum output less than 0.02 V into 50 ohms; rotating vernier to minimum (ccw) may increase preshoot to 10%.  
**Source RC:** 600 ohms  $\pm 10\%$ .  
**Rise and fall times:** less than 70 nsec into 600 ohms, less than 140 nsec into an open circuit; decreased amplitude setting will improve rise time.  
**Overshoot and ringing:** less than 5%.  
**Amplitude:**  
**Peak voltage:** at least 30 V into 600 ohms, at least 60 V into an open circuit.  
**Attenuator:** provides continuous adjustment from full output to less than 0.3 V into 600 ohms.

### Repetition rate and triggering

#### Internal:

##### Repetition rate:

50 ohm output: 1 Hz to 10 MHz, 7 ranges.

600 ohm output: 1 Hz to 1 MHz, 6 ranges.

Dial calibration: 1-10 (linear).

Accuracy:  $\pm 5\%$  to 10 MHz at 50% duty cycle; variation of symmetry control may change frequency an additional  $\pm 5\%$  (10% on 10 MHz range).

Period jitter: less than 0.2% at any duty cycle and rep rate setting.

#### External:

**Sync input:** sine waves or positive pulses from 1 Hz to 10 MHz; frequency of synchronizing signal must be 105-140% of dial setting.

**Sensitivity:** dc coupled positive pulses, 1 V peak; sine waves, 2 V peak-to-peak.

**Input resistance:** approximately 500 ohms.

**Trigger output pulse:** (suitable for synchronizing with another Model 211B).

**Width:** 10 ( $\pm 5$ ) nsec at 50% points.

**Amplitude:** at least 1 V into 50 ohms.

**Timing:** coincident with leading edge of 50 ohm pulse.

**Polarity:** positive or negative.

#### General

**Power:** 115 or 230 V  $+10\%$   $-15\%$ ; 50 to 400 Hz; 23 watts.

**Dimensions:** 7 $\frac{3}{4}$ " wide, 6 $\frac{1}{8}$ " high, 11" deep overall (190 x 155 x 279 mm).

**Weight:** net 9 lbs (4 kg); shipping 11 lbs (5 kg).

**Price:** HP Model 211B, \$395.

### Model 211A Square Wave Generator

The Model 211A Square Wave Generator is a versatile, wide-range instrument particularly designed for testing video and audio amplifier performance, or for use as a trigger generator. It provides complete coverage of all frequencies from 1 Hz to 1 MHz, and has a rise time of 0.02 microsecond. There are two separately variable outputs—a 3.5-volt peak 75-ohm impedance circuit for television measurements, and a 27-volt peak 600-ohm output for high-level work. The generator may be operated free-running or externally synchronized.

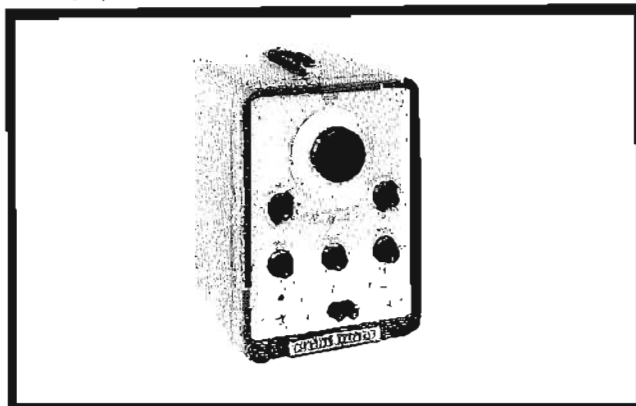



### Specifications, Model 211A

**Frequency range:** 1 Hz to 1 MHz, continuous coverage.  
**Low impedance output:** —3.5 volts peak across 75-ohm load; —7 volts open circuit, zero level clamped to chassis; rise time less than 0.02  $\mu$ sec.  
**High Impedance output:** —27 volts peak across 600-ohm load; —55 volts open circuit, zero level clamped to chassis; rise time less than 0.1  $\mu$ sec.  
**Relative phase:** 180° phase difference between high- and low-impedance output signals.  
**Amplitude control:** low impedance output, potentiometer and 60 dB attenuator, variable in 20 dB steps; high impedance output, potentiometer.  
**Frequency control:** dial calibrated "1 to 10" and decade multiplier switch; six bands.  
**Symmetry control:** allows exact square-wave balance.  
**Sync Input:** positive-going pulse or sine wave signal, minimum amplitude 5 volts peak.  
**Power:** 115 or 230 volts  $\pm$ 10%, 50 to 60 Hz, 225 watts.  
**Dimensions:** cabinet: 9 $\frac{3}{4}$ " wide, 15 $\frac{1}{4}$ " high, 14 $\frac{3}{8}$ " deep (238 x 388 x 372 mm); rack mount: 19" wide, 8 $\frac{3}{4}$ " high, 13 $\frac{3}{8}$ " deep behind panel (483 x 222 x 340 mm).  
**Weight:** net, 26 lbs (11,7 kg); shipping, 29 lbs (13 kg) (cabinet); net, 24 lbs (10,8); shipping, 35 lbs (15,8 kg) (rack mount).  
**Price:** HP Model 211A, \$350 (cabinet); HP Model 211AR, \$355 (rack mount).

### Model 1105A/1106A 20 psec Pulse Generator

The Model 1105A/1106A produces a pulse of about 20 psec rise time, ideal for fast circuit testing or high resolution TDR. The pulser is made up of two parts: the Model 1105A Pulse Generator Supply and the Model 1106A Tunnel Diode Mount. The Model 1106A may also be used with the Model 1104A Countdown Supply to form an 18 GHz trigger countdown.

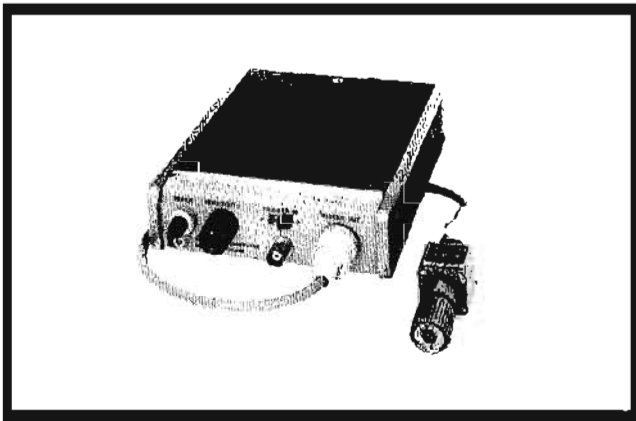

### Specifications, Model 1105A/1106A

#### Output

**Rise time:** approximately 20 psec; less than 35 psec observed with HP Model 1411A/1430A 28 psec Sampler and HP Model 909A 50 ohm termination.  
**Overshoot:** less than  $\pm$ 5% as observed on Model 1411A/1430A with Model 909A.  
**Droop:** less than 3% in first 100 nsec.  
**Width:** approximately 3  $\mu$ sec.  
**Amplitude:** greater than +200 mV into 50 ohms.  
**Output characteristics (Model 1106A):**

**Mechanical:** precision 7 mm (Amphenol APC-7) connector.

**Electrical:** dc resistance, 50 ohms  $\pm$ 2%; source reflection, less than 10%, using a 40 psec TDR system; dc offset voltage, approximately 0.1 V.

#### Triggering

**Amplitude:** at least  $\pm$ 0.5 V peak required.  
**Rise time:** less than 20 nsec required; jitter less than 15 psec when triggered by 1 nsec rise time sync pulse from Model 1424A or 1425A Sampling Time Base sync pulse; jitter increases with slower trigger rise times.  
**Width:** greater than 2 nsec.  
**Maximum safe input:** 10 volts.  
**Input impedance:** 200 ohms, ac coupled through a 20 pF capacitor.

**Repetition rate:** 0 to 100 kHz; free runs : approx 100 kHz.

#### Accessories provided (with Model 1105A):

One 6-ft 50-ohm cable with male Type N connectors, HP Model 10132A.

#### Weight:

**Model 1105A:** net, 3 lbs (1,4 kg); shipping, 8 lbs (3,6 kg).  
**Model 1106A:** net, 1 lb (0,5 kg); shipping, 3 lbs (1,4 kg).  
**Price:** HP Model 1105A, \$200; HP Model 1106A, \$550.

### Model 213B 100 psec Pulse Generator

The outstanding performance of the Model 213B makes it convenient for many small amplitude pulse test applications ranging from circuit rise time testing and bandwidth determinations to the measurement of transistor switching speeds.

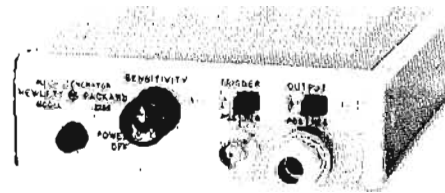

### Specifications, Model 213B

#### Output

**Rise time:** less than 100 psec.  
**Top droop:** less than 2% in first 100 nsec following the rise.  
**Width:** approximately 2  $\mu$ sec.  
**Amplitude:** greater than 175 mV into 50 ohms, 350 mV open circuit, either polarity.  
**Source:** 50 ohms.  
**Jitter:** less than 20 psec when triggered with the sync pulse from a Model 1424A or 1425A.  
**Repetition rate:** free runs at a rate greater than 100 kHz, or may be triggered.

#### Trigger input

**Amplitude:** 0.5 volt peak, either polarity.  
**Rise time:** 20 nsec or faster.  
**Width:** at least 2 nsec.  
**Maximum current:** 200 mA peak.  
**Impedance:** 200 ohms for signals less than 0.75 volt peak; limiting lowers impedance to larger signals.  
**Repetition rate:** 0 to 100 kHz.

#### General

**Power:** 115 or 230 volts  $\pm$ 10%, 50 to 1000 Hz, approx 1 watt.  
**Dimensions:** 11 $\frac{1}{2}$ " high, 5 $\frac{1}{8}$ " wide, 5" deep (38 x 130 x 127 mm).  
**Weight:** net, 2 lbs (0,9 kg); shipping, 4 lbs (1,8 kg).  
**Price:** HP Model 213B, \$250.

## PULSE GENERATORS

Ideal pulsers for fast circuit work  
Models 8000A, 8001A



## SIGNAL SOURCES

### Model 8001A Pulse Generator

The Model 8001A Pulse Generator provides pulses with 1 nanosecond rise and fall times and with exceptionally well controlled shape. Variable amplitude, delay, width, and repetition rate make it an ideal pulse source for testing high speed semiconductor devices and broadband circuits.

The output is carefully specified in every respect for accurate dependable measurements. A vernier and step attenuator allows continuous adjustment of pulse amplitude from 0.04 V to 10 V. Internal repetition rates from 100 Hz to 200 kHz can be selected in three overlapping ranges. The 8001A may also be triggered externally for repetition frequencies from dc to 270 kHz. A countdown circuit enables synchronization up to 10 MHz.

### Specifications, 8001A

#### Pulse shape

##### Leading edge characteristics:

Rise time: < 1 ns.

Overshoot and ringing: < 3% peak of pulse amplitude.

Perturbations on flat top: < 2% of pulse amplitude.

##### Trailing edge characteristics:

Fall time: < 1 ns.

Overshoot and ringing: < 6% peak of pulse amplitude.

#### Amplitude

Max. voltage: 10 volts across 50 ohms.

Attenuator: provides seven steps from 0.1 to 10 volts in a 1, 2, 5 sequence.

Vernier: provides continuous adjustments between ranges, minimum output less than 0.04 volts across 50 ohms.

Polarity: positive or negative.

Source impedance: 50 ohms nominal.

Pulse width: continuously variable from 100 ns to 500 ns.

#### Repetition rate and trigger

##### Internal:

Repetition rate: 100 Hz to 200 kHz in 3 ranges, continuously variable.

Manual: pushbutton for single pulse.

##### External:

Triggering: dc-coupled; pulses or sine waves from 0-270 kHz; either positive or negative slope.

Count down: counts down frequencies up to 10 MHz.

#### Trigger output pulse

Polarity: positive.

Amplitude: at least 2 volts across 50 ohms.

Width: 20 ( $\pm 4$ ) ns at 50% points.

Timing: main pulse adjustable from 100 ns advance to 300 ns delay with respect to output pulse.

#### General

Power: 115 V/230 V switch  $\pm 15\%$ , 50-60 Hz 35 watts.

Dimensions: 16 $\frac{3}{4}$ " wide, 5 $\frac{1}{2}$ " high, 13 $\frac{1}{4}$ " deep (425 x 140 x 336 mm).

Weight: net 17 lbs (7.5 kg); shipping 23 lbs (10 kg).

Price: HP Model 8001A, \$1070.

Manufactured by Hewlett-Packard GmbH., West Germany.

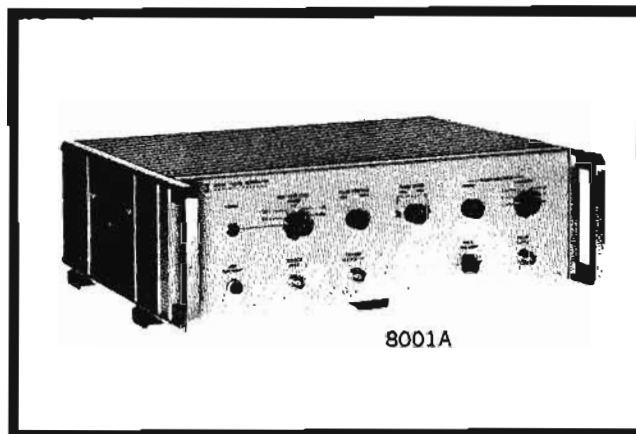

### Low-priced 1 nsec pulser, Model 8000A

The HP Model 8000A Pulser provides 1 nanosecond rise time pulses at a 100 kHz repetition rate. Fast rise time and clean pulse shape make this instrument particularly suitable for accurate determination of the pulse response of high-speed components, circuits and instruments. Amplitude is adjustable in 1, 2, 5 sequence from 0.1 volts to 10 volts, either polarity. An advanced trigger is available 200 nsec in advance of the pulse, so the pulser may be used with sampling oscilloscopes without delay lines.



### Specifications, 8000A

#### Output pulse

Rise time: < 1 nanosecond for negative pulses; < 1.2 nanoseconds for positive pulse.

Amplitude: 0.1 V to 10 V into 50 ohms, adjustable in 1, 2, 5 sequence.

Polarity: positive or negative.

Shape: overshoot and pulse top variations  $< \pm 2\%$ .

Width: flat top maintained for at least 100 nanoseconds.

Fall time: < 20 nanoseconds.

Repetition rate: 100 kHz  $\pm 20\%$ .

Source impedance: 50 ohms nominal.

#### Trigger pulse

Timing: 200 nanoseconds advance  $\pm 20\%$ .

Jitter: < 100 picoseconds, trigger to output.

Rise time: < 6 nanoseconds.

Amplitude: 0.5 V into 50 ohms.

Polarity: negative.

Width: 20 nanoseconds  $\pm 20\%$  (between 10% points).

#### General

Power: 115 V/230 V switch  $\pm 10\%$ , 50 to 400 Hz.

Dimensions: 5 $\frac{1}{8}$ " wide, 3-7/16" high, 11 $\frac{5}{8}$ " deep (130 x 87 x 295 mm).

Weight: net 4 lbs (1.8 kg); shipping 6 lbs (2.7 kg).

Price: HP Model 8000A, \$375.

Manufactured by Hewlett-Packard GmbH., West Germany.



## DIGITAL DELAY GENERATOR

Digitally controlled time intervals, pulses  
Model 218AR

The HP 218AR Digital Delay Generator is designed to generate precise time intervals and single, double or superimposed pulses. It is useful as a general-purpose laboratory pulse generator and because of its versatile plug-in pulse generators, it often can take the place of several special-purpose instruments.

The 218AR consists of (1) a pulsed crystal oscillator which is started in known phase by the initial trigger (start) pulse, eliminating the  $\pm 1$  count error; (2) a dual-preset digital counter which counts the crystal or externally applied frequency, and operates (3) two preset gates which pass the selected pulses.

Plug-ins include the 219A Dual Trigger Unit to supply

trigger pulses for controlling auxiliary equipment, \$125; the 219B Dual Pulse Unit to deliver fast-rise-time, high-power pulses that are digitally delayed, \$490; and the 219C Digital Pulse Duration Unit, which produces a high-power output pulse whose delay and duration may be digitally controlled, \$375. Output pulses of the 219A are identical to the sync output of the 218AR. The 219B pulses are individually adjustable, 0 to  $\pm 50$  V peak open circuits from a 50-ohm source. Pulses from the 219C are 90 V peak (or more), open circuit, from a 500-ohm source or adjustable from 0 to 15 V peak from a 90-ohm source. The positive excursion of the pulses is clamped to ground, and both positive- and negative-going pulses are available simultaneously.

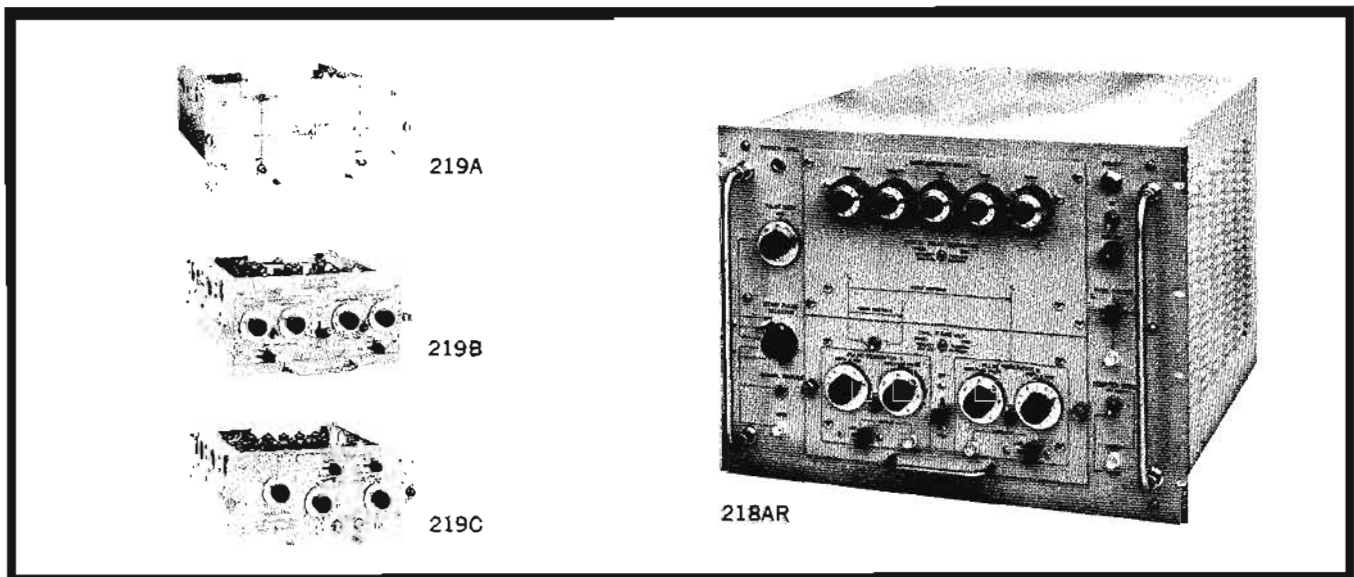

### Specifications

(Plug-in necessary to operate)

**Time interval range:** ( $T_0$  to  $T_1$  and  $T_0$  to  $T_2$ ) 1 to 10,000  $\mu\text{sec}$ ; accuracy  $\pm 0.1 \mu\text{sec} \pm 0.001\%$  of time interval selected.

**Digital adjustment:** 1 to 9999  $\mu\text{sec}$  in 1  $\mu\text{sec}$  steps.

**Interpolation:** continuously adjustable; adds 0 to 1  $\mu\text{sec}$  to digital setting.

**Input trigger:** internal: 10 Hz to 10 kHz, 3 decade ranges; external: sine wave, 10 to 100 Hz, 5 to 40 V rms, 100 Hz to 10 kHz, 2 to 40 V rms; pulse, 0 to 10 kHz, positive or negative, 2 to 40 V peak; for trigger rise time of 0.05  $\mu\text{sec}$  or less, delay between external trigger and  $T_0$  is less than 0.5  $\mu\text{sec}$ ; manual: pushbutton operation initiates single pulse cycle.

**Jitter:** 0.02  $\mu\text{sec}$  or less.

**Recovery time:** 70  $\mu\text{sec}$  or 10% of selected interval, whichever is greater.

**Sync output:** positive pulse, 50 to 70 V peak, open circuit,

0.1  $\mu\text{sec}$  rise time; width more than 1.5  $\mu\text{sec}$ ; available at  $T_0$ ,  $T_1$ , or  $T_2$  as selected by a switch.

**1 MHz output:** 1 MHz positive pulses (1 V from 500-ohm source) provide timing comb synchronized to start pulses; available at panel connector for duration of longer delay when counting internal 1 MHz oscillator.

**External counting:** external sine waves, 100 Hz to 1 MHz, 2 V rms minimum; 10 to 100 Hz, 5 V rms minimum, and positive pulses, periodic or random, 0 to 1 MHz, 2 V peak, can be counted instead of internal standard; time interval range becomes 3 to 9999 periods in 1-period steps, and accuracy is  $\pm 0.1 \mu\text{sec} \pm 1$  period.

**Power:** 115 or 230 V  $\pm 10\%$ , 50 to 60 Hz, 555 W.

**Dimensions:** 14" high, 19" wide, 21 $\frac{3}{4}$ " deep behind panel (355 x 483 x 553 mm).

**Weight:** net 74 lbs (34 kg); shipping 103 lbs (47 kg).

**Price:** HP 218AR, \$2250 (requires HP 219A,B,C Series plug-in units).

# PULSE GENERATOR

Economical general-purpose testing  
Model 222A



## SIGNAL SOURCES

The Model 222A combines many features normally found only on more expensive instruments to provide an easy-to-use, yet versatile, general-purpose pulse generator. The 4 nsec rise time and full complement of controls permit a wide variety of pulse testing, including square wave testing, Oscilloscope-type triggering, variable pulse width, repetition

rates to 10 MHz, closely specified pulse shape and many other features provide accurate, dependable measurements. The Model 222A, like other HP pulse generators, has a 50-ohm output impedance for eliminating error-producing reflections. The output pulse may be delayed from the trigger output by up to 5 msec for further measurement convenience.

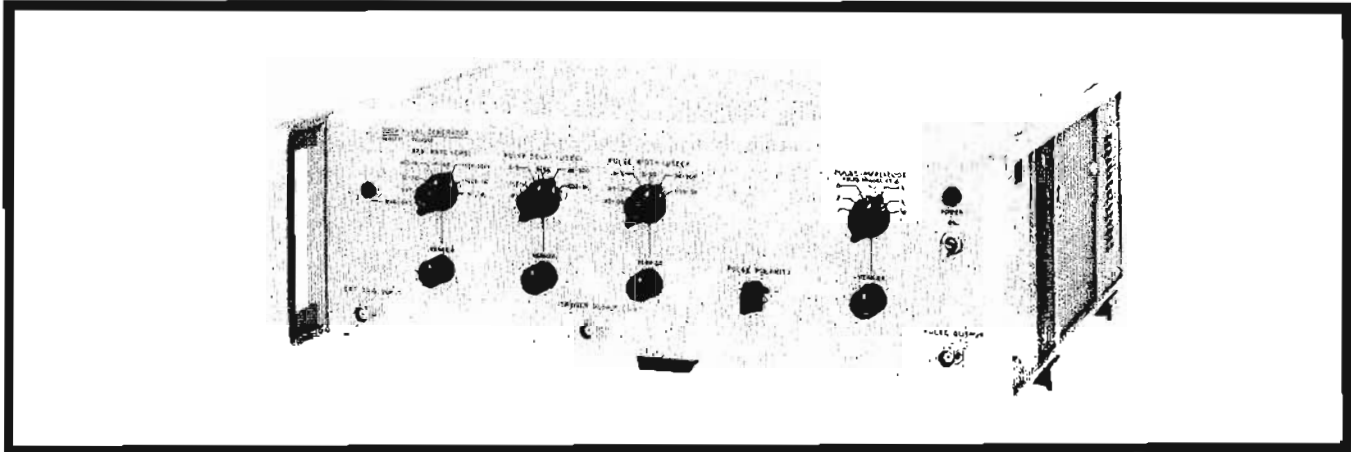

### Specifications

#### Output pulse

**Source RC:** 50 ohms shunted by approximately 15 pF throughout specified output voltage range.

#### Amplitude

**Peak voltage:** 10 volts across 50 ohms; approximately 12 volts maximum.

**Amplitude control:** step attenuator provides 0.1, 0.2, 0.5, 1, 2, 5, 10 volts across 50 ohms; continuously variable between steps; minimum output less than 0.05 volts.

**Polarity:** positive or negative.

#### Pulse width

**Range:** 30 nsec to 5 msec in 6 ranges, continuously variable between ranges.

**Duty cycle:** maximum duty cycle >50% from 100 Hz to 10 MHz; for maximum stability at high duty cycles, select width range which allows maximum clockwise rotation of width vernier; duty cycle from 10 to 100 Hz limited by 5 msec maximum pulse width.

**Width jitter:** <0.2% of maximum range width.

#### Pulse shape

**Leading edge only** (measured at 10 volts into 50 ohms)

**Rise time:** <4 nsec.

**Overshoot and ringing:** <4% peak of pulse amplitude.

**Corner rounding:** occurs no sooner than 95% of pulse amplitude.

**Time to settle within 3% of flat top:** approximately 20 nsec.

**Preshoot:** <2%.

**Trailing edge only** (measured at 10 volts into 50 ohms)

**Fall time:** <4 nsec.

**Overshoot and ringing:** <4% peak of pulse amplitude.

**Corner rounding:** occurs no sooner than 95% of pulse amplitude.

**Time to settle within 2% of base line:** less than 20 nsec.

**Preshoot:** <4%.

**Perturbations on flat top:** <3% of pulse amplitude.

**Pulse delay:** pulse delayed from trigger output by <100 nsec to 5 msec in 6 ranges, continuously variable between ranges.

**Delay jitter:** <0.2% of maximum delay.

#### Repetition rate and trigger

##### Internal

**Repetition rate:** 10 Hz to 10 MHz in 6 ranges, continuously variable between ranges.

**Jitter:** period jitter in any frequency range <0.2% of maximum period of that range.

**Manual:** pushbutton single pulse.

##### External

**Triggering:** ac coupled; sine wave from 10 Hz to 10 MHz, pulse from 0 to 10 MHz, either positive or negative slope.

**Sensitivity:** 1 volt p-p minimum; external pulses must be at least 10 nsec wide; maximum input 20 volts peak; 0.25 watt maximum average power.

**Input resistance:** approximately 500 ohms.

**External trigger delay:** less than 20 nsec between leading edge of external trigger input pulse and leading edge of trigger output pulse.

#### Trigger output pulse:

**Width:** 22 (±8)nsec at 50% points.

**Amplitude:** >1 volt into 50 ohms.

**Rise time:** <10 nsec.

**Polarity:** negative.

#### General

**Power:** 115 or 230 V ±10%, 50 to 60 Hz, 80 W.

**Dimensions:** 16¾" wide, 5½" high, 13¼" deep (425 x 140 x 336 mm); hardware furnished for quick conversion to 5¼" x 19" rack mount, 11¾" deep behind panel (133 x 483 x 298 mm).

**Weight:** net 18 lbs (8 kg); shipping 23 lbs (10.4 kg).

**Price:** HP Model 222A, \$690.



## PULSE GENERATOR

Delivers 200 watts pulse power  
Model 214A

The HP Model 214A features 200 watts pulse power, controlled pulse shape, external trigger slope and level selection, and a 50-ohm source impedance for general-purpose lab and production measurements.

The 200-watt (2 amps peak) pulse power is particularly suited for testing current-driven devices such as magnetic memory cores, as well as high-power modulators. At output levels below 50 volts, the pulse generator has a matched source impedance of 50 ohms, eliminating error-producing reflections. The pulse characteristics are carefully controlled, and pulse rate, width and delay jitter are kept to a minimum

to insure accurate, dependable test results.

The 214A offers an extremely wide range of trigger control for syncing on external signals. In addition, slope and level may be selected so that triggering occurs at a given point on the trigger waveform. Also provided is a variable delay or advance trigger output signal for use in synchronizing external equipment.

The pulse generator may be gated to provide bursts of pulses. This feature is especially useful for computer logic measurements. Also, a double pulse feature is provided for pulse resolution tests of amplifiers and memory cores.

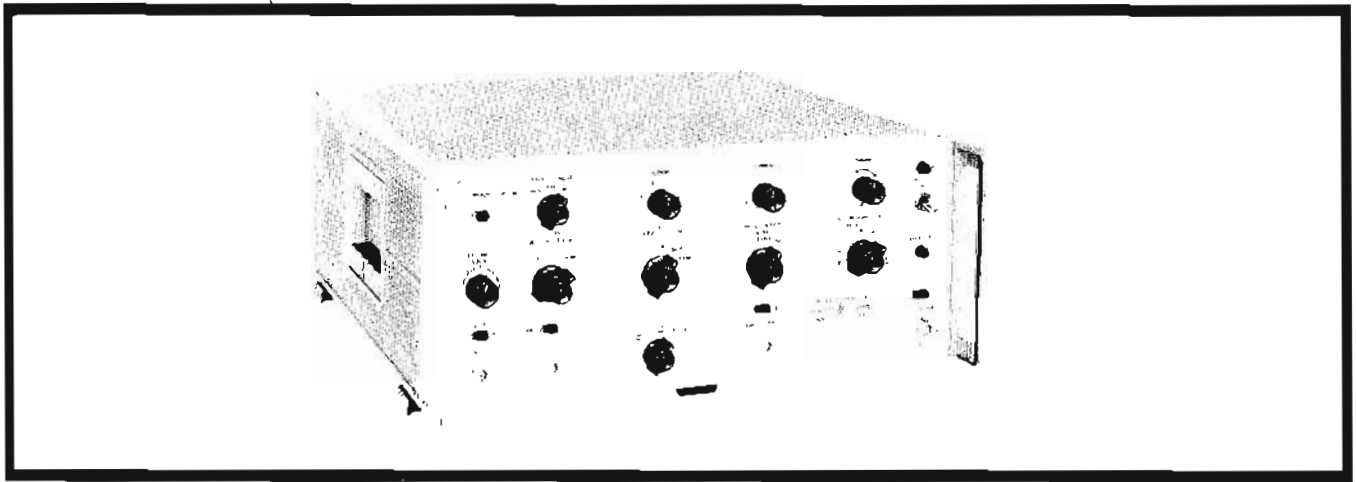

### Specifications

#### Output pulse

**Source resistance:** 50 ohms on the 50 V and lower ranges; approximately 1500 ohms on the 100 V range.

#### Pulse shape:

Rise and fall time: <13 nsec on the 20 V and lower ranges and the -50 V range, <15 nsec on the +50 V range; typically <10 nsec with the vernier set for maximum attenuation, and typically 15 nsec on 100 V range.

Pulse amplitude: 100 V into 50 ohms. An attenuator provides 0.2 to 100 V in a 1, 2, 5, 10 sequence (9 ranges); vernier reduces output of 0.2 V setting to 80 mV and provides continuous adjustment between ranges.

Polarity: positive or negative.

Overshoot: <5%, both leading and trailing edges.\*

Pulse top variations: <5%.

Drop: <6%.

Preshoot: <2%.

Pulse width: 50 nsec to 10 msec in 5 decade ranges; continuously adjustable vernier.

Width jitter: <0.05% of pulse width +1 nsec.

**Pulse position:** 0 to 10 msec advance or delay with respect to trigger output (5 decade ranges) continuously adjustable vernier.

**Position jitter:** <0.05% of advance or delay setting +1 nsec (between trigger pulse and output pulse).

#### Repetition rate and trigger

##### Internal

Repetition rate: 10 Hz to 1 MHz (5 ranges), continuously adjustable vernier.

Rate jitter: <0.5% of the period.

Manual: pushbutton single pulse, 2 Hz maximum rate.

##### External

Repetition rate: dc to 1 MHz.

Sensitivity: <0.5 V peak.

Slope: positive or negative.

Level: adjustable from -40 V to +40 V.

Delay: delay between input (trigger) and leading edge of pulse out is approx. 250 nsec. in Pulse Advance mode (approx. 420 nsec minimum in Pulse Delay mode).

**External gating:** +8 V signal gates pulse generator on; maximum input, 40 V peak.

##### Double pulse

Minimum spacing: 1  $\mu$ sec on the 0.05 to 1  $\mu$ sec pulse width range and 25% of upper limit of width range for all other ranges.

##### Trigger output

Amplitude: >10 V open circuit.

Source resistance: approximately 50 ohms.

Width: 0.05  $\mu$ sec, nominal.

Polarity: positive or negative.

##### General

**Maximum duty cycle:** 10% on 100 and 50 V ranges; 25% on 20 V range; 50% on 10 V and lower ranges.

**Power:** 115 or 230 V  $\pm$  10%, 50 to 60 Hz, 325 W.

**Dimensions:** 16 $\frac{3}{4}$ " wide, 7 $\frac{1}{4}$ " high, 18 $\frac{3}{8}$ " deep overall (425 x 184 x 466 mm); hardware furnished for quick conversion to 7" x 19" rack mount, 16 $\frac{3}{8}$ " deep behind panel (178 x 483 x 416 mm).

**Weight:** net 35 lbs (15.8 kg); shipping 41 lbs (18.5 kg).

**Price:** HP 214A, \$875.

\*Measured on a 50 MHz oscilloscope.

# PULSE GENERATOR

Controlled, fully specified output pulses  
Model 215A



## SIGNAL SOURCES

The Model 215A Pulse Generator combines in one compact unit the many capabilities desired for fast pulse testing. The fast rise and fall time and extremely low pulse jitter make the Model 215A particularly useful in measuring transition storage times of semiconductors, logic circuits and thin film memory units.

The output pulse of the Model 215A is carefully controlled to approximate an ideal pulse shape and is specified in every respect for accurate, dependable measurements. One nano-

second rise and fall time pulses of either polarity with nearly an ideal pulse shape, combined with calibrated pulse width and delay controls, adjustable pulse amplitude, variable pulse rate to 1 MHz and a true 50-ohm source impedance provide maximum measurement capabilities.

The true 50-ohm source impedance insures clean output pulses, regardless of the load impedance, since any reflection from the circuit under test will be absorbed by the 50-ohm generator impedance.

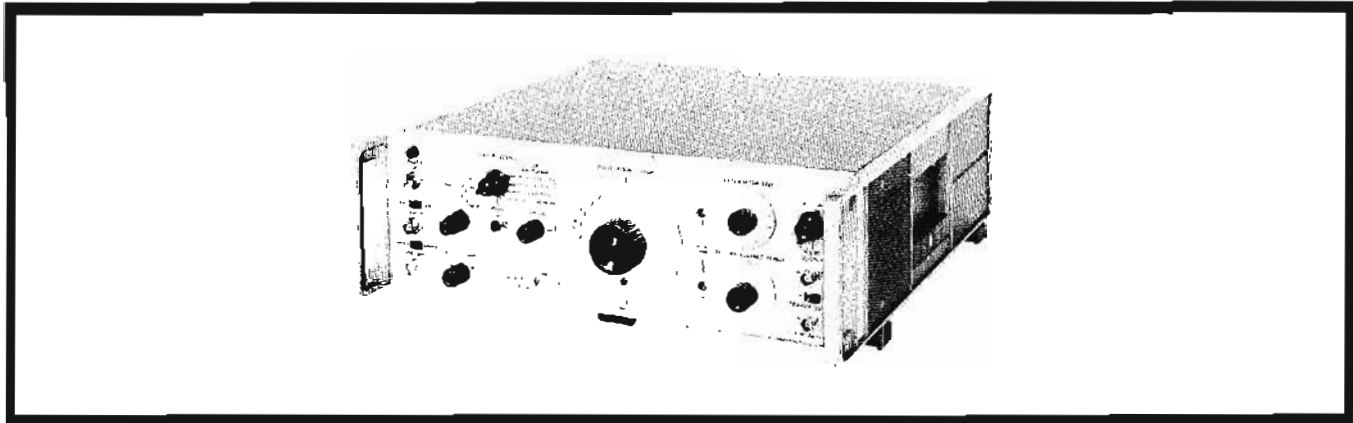

### Specifications

**Source impedance:** 50 ohms  $\pm 3\%$ ; 3% maximum reflection when driven by a pulse with 1 nsec rise time from an external 50-ohm system.

#### Leading edge only

Rise time:  $< 1$  nsec (10 to 90% points).  
Overshoot and ringing: overshoot,  $< 5\%$  peak; ringing,  $< \pm 5\%$  of pulse amplitude.  
Corner rounding: occurs no sooner than 95% of pulse amplitude.  
Time to achieve flat top:  $< 6$  nsec.

#### Trailing edge only

Fall time:  $< 1$  nsec (10 to 90% points).  
Overshoot:  $< 5\%$ .  
Rounding: occurs no sooner than 95% of fall.  
Time to settle within 2% of baseline: 10 to 25 nsec, varies with width setting.

**Baseline shift:**  $< 0.1\%$  under all conditions.

**Preshoot:**  $< 1\%$ .

**Perturbations on flat top:**  $< 2\%$  of pulse amplitude.

**Peak voltage:**  $> 10$  volts into 50 ohms;  $> 20$  volts open circuit.

**Polarity:** positive or negative.

**Attenuator:** 0 to 12 dB in 1 dB steps, absolute accuracy within  $\pm 0.1$  dB.

**Pulse width (between 50% points):** continuously adjustable to 100 nsec; dial accuracy within  $\pm 5\% \pm 3$  nsec, width jitter less than 50 psec.

**External bias:** up to  $\pm 100$  mA ( $\pm 5$  V dc) may be safely applied to the output; at 0 dB attenuator setting, up to 10 mA (0.5 V dc) may be applied without significant change in pulse shape (5% droop), increasing to 40 mA at 12 dB; in most cases, adjusting the front-panel pulse-shape controls will restore original pulse shape.

#### Repetitive rate sources

Internal repetition rate:  $< 100$  Hz to  $> 1$  MHz in 4 ranges, continuously variable between ranges; period jitter  $< 3 \times 10^{-3}$  of one period.

Manual: pushbutton single pulse.

**Trigger timing:** adjustable from 10 nsec delay to 140 nsec advance with respect to leading edge of output pulse; dial accuracy within  $\pm 10\% \pm 5$  nsec; jitter  $< 50$  picoseconds.

**External triggering:** ac coupled, sine waves from 10 Hz to 1 MHz; pulses from 0 to 1 MHz, either positive or negative slope.

**Trigger level:** external trigger level continuously variable, from approximately +8 to -8 volts.

**Sensitivity:** 1 V peak to peak min.; external pulses must be at least 30 nsec wide; max. input 50 V peak, 0.5 W max. average power.  
**Input resistance:** approx. 50 ohms or High Z available by front-panel switch; High Z is approx. 100 k $\Omega$  for negative slope setting, approx. 5 k $\Omega$  for positive slope setting.

**Countdown:** counts down from frequencies to 100 MHz, 2 V rms amplitude; resulting pulse repetition rate is always  $< 1.3$  MHz; jitter is  $< 10\%$  of one period of the triggering signal.

**External trigger delay:** approximately 250 nsec between leading edge of trigger pulse (2 volt step, 2 nsec rise time into 50 ohms) and leading edge of output pulse;  $< 50$  psec jitter.

**External gating:** gates on with a +1 volt pulse; maximum input 50 V peak, 20 V rms.

#### Trigger output pulses

Width: 50 nsec, nominal.

Amplitude:  $> 1$  volt peak into 50 ohms.

Rise time:  $< 6$  nsec.

Polarity: positive or negative.

**Power:** 115 or 230 volts  $\pm 10\%$ , 50 to 60 Hz, 60 watts.

**Dimensions:** 5 $\frac{1}{2}$ " high, 16 $\frac{3}{4}$ " wide, 18 $\frac{3}{8}$ " deep (175 x 425 x 466 mm); hardware furnished for quick conversion to 5 $\frac{1}{4}$ " x 19" rack mount, 16 $\frac{3}{8}$ " deep behind panel (134 x 483 x 416 mm).

**Weight:** net 34 lbs (15,3 kg); shipping 41 lbs (18,5 kg).

**Accessories furnished:** Model 10120A cable, 3 feet, BNC-to-BNC, 50 ohms  $\pm 0.5$  ohm.

**Accessories available:** Model 10122A cable, 3 feet, BNC-to-Type N, 50 ohms  $\pm 0.5$  ohm, \$10; Model 908A, 50-ohm Coaxial Termination, \$35; Model 10451A Multipulser generates pulse bursts to simulate 15 to 200 MHz rep rate, \$150; Model 10240A Blocking Capacitor, 0.1  $\mu$ F, isolates Model 215A from up to 200 V dc, \$70.

**Price:** HP Model 215A, \$1875.



## PULSE GENERATOR

Fast-rise 100 MHz pulses  
Model 216A

The Model 216A offers pulse repetition rates up to 100 MHz for testing fast circuits, yet retains a nearly ideal pulse shape with 2.5 nsec rise time for accurate, dependable measurements. In addition, bursts of pulses may be produced internally to simulate pulse trains for logic circuit testing.

Pulse height is continuously variable, allowing exact pulse amplitudes to be selected for precise testing. The dc-coupled output eliminates baseline shift with changes in rep rate, and the 50-ohm output impedance prevents multiple reflections, insuring clean, easy-to-interpret waveforms.

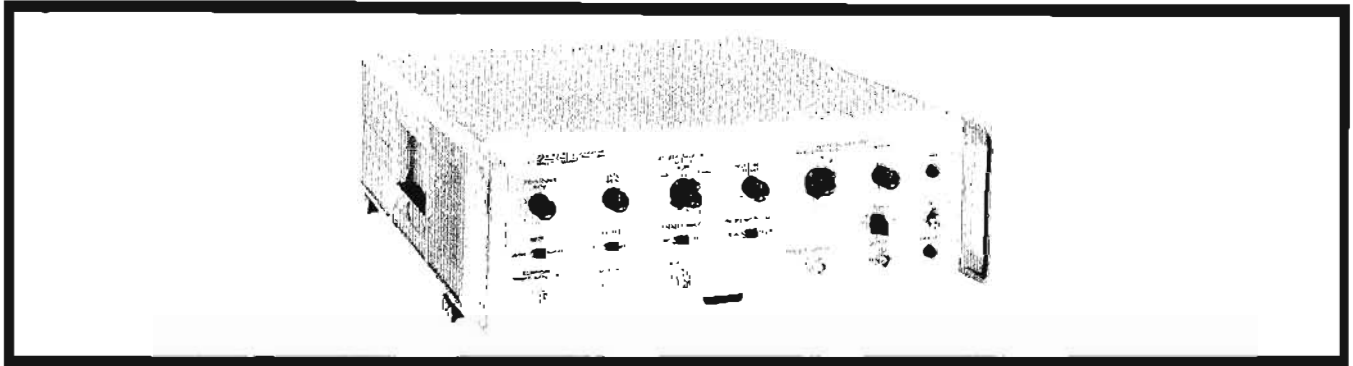

### Specifications

**Source RC:** 50 ohms,  $\pm 3\%$ , shunted by approximately 10 pF throughout specified output voltage range.

**Leading edge only** (at 10 V output into 50-ohm load).

**Rise time:**  $< 2.5$  nsec.

**Overshoot and ringing:** overshoot  $< 4\%$  peak, ringing  $\pm 4\%$  p-p of pulse amplitude.

**Corner rounding:** occurs no sooner than 96% of pulse amplitude.

**Time to achieve flat top:** approximately 20 nsec.

**Preshoot:**  $< 3\%$ .

**Trailing edge only** (at 10 V output into 50-ohm load).

**Fall time:**  $< 2.5$  nsec.

**Overshoot:**  $< 4\%$ .

**Corner rounding:** occurs no sooner than 96% of fall.

**Time to settle within 2% of base line:** approx. 20 nsec.

**Preshoot:**  $< 5\%$ .

**Perturbations on flat top:**  $< 3\%$  of pulse amplitude.

**Peak voltage:**  $> 10$  volts into 50 ohms to 100 MHz, (15 volts maximum amplitude into open circuit).

**Attenuator:** 1, 2, 5, 10 volt steps.

**Polarity:** positive or negative.

**Vernier:** provides continuous adjustment from approximately 0.3 volts to 10 volts.

**Pulse width:** continuously variable in two ranges, from approximately 5 nsec to 25 nsec and from 25 nsec to 100 nsec; width jitter  $< 100$  psec  $+ 0.3\%$  of pulse width with count-down ratio set for minimum jitter.

**Maximum duty cycle:**  $> 45\%$  up to 50 MHz decreasing to approximately 20% at 100 MHz.

**Internal repetition rate:** 1 MHz to 100 MHz in 3 ranges.

#### External triggering

**Frequency:** sine waves from 1 MHz to 100 MHz, negative pulses from 0 to 100 MHz; pulse rise time  $< 100$  nsec; pulse width  $> 2$  ns.

**Sensitivity:** at least 0.5 volt peak minimum; maximum input, 10 volt peak.

**Input impedance:** approximately 50 ohms, ac coupled.

**External trigger delay:** approximately 140 nsec  $\pm 10\%$  between leading edge of input trigger pulse and leading edge of output pulse.

#### Trigger output pulse

**Width:** 3.5 nsec  $\pm 1$  nsec.

**Amplitude:**  $> 0.7$  volts peak into 50 ohms.

**Polarity:** negative.

**Trigger timing:** approximately 130 nsec  $\pm 10\%$  advance with respect to leading edge of output pulse.

#### Countdown trigger output

**Amplitude:**  $> 0.5$  volt peak into 50 ohms.

**Polarity:** positive.

**Countdown frequency:** variable from approximately 250 kHz to 450 kHz.

#### Gating of pulse bursts

##### Internal

**Gate width:** variable from approx. 20 nsec to 750 nsec.

**Gate repetition rate:** variable from approximately 250 kHz to 450 kHz.

**External:** gates on with  $\pm 2$  volt pulse having rise and fall times of  $< 5$  nsec; maximum input, 10 volts.

**Perturbations:** perturbations on gate envelope  $< 5\%$  into 50 ohms, above 50 MHz width varies slightly from pulse to pulse.

#### General

**Power:** 115 or 230 volts  $\pm 10\%$ , 50 to 60 Hz, 120 watts.

**Dimensions:** 5 $\frac{1}{2}$ " high, 16 $\frac{3}{4}$ " wide, 18 $\frac{3}{8}$ " deep (175 x 425 x 466 mm), hardware furnished for quick conversion to 5 $\frac{1}{4}$ " x 19" rack mount, 16 $\frac{3}{8}$ " deep behind panel (134 x 483 x 416 mm).

**Weight:** net 25 lbs (11 kg); shipping 31 lbs (14 kg).

**Accessories available:** Model 10120A Cable, 3 feet, BNC-to-BNC, 50 ohms  $\pm 0.5$  ohm, \$10; Model 10122A Cable, 3 feet, BNC-to-Type N, 50 ohms  $\pm 0.5$  ohm, \$10; Model 908A 50-ohm Coaxial Termination, \$35; Model 10240A Blocking Capacitor, 0.1  $\mu$ F, isolates Model 216A from up to 200 V dc, \$70.

**Price:** HP Model 216A, \$1775.





Signal sources have been described by various names—oscillators, test oscillators, audio signal generators, etc. Different names are applied, depending on the design and intended use of the source. The oscillator is basic to all the sources and generates sine-wave signals of known frequency and amplitude. In the recently developed transistorized sources, the name "test oscillator" has been used to describe an oscillator having a calibrated attenuator and output monitor. The term "signal generator" is reserved for an oscillator with modulation capability.

Oscillators generate a broad range of frequencies at a variety of power levels for many different load impedances. Table 1 illustrates the frequency range and power output of Hewlett-Packard oscillators. The 651B, for example, covers a frequency range from 10 Hz to 10 MHz with a power of 200 mW into 50 ohms, or 16 mW into 600 ohms.

### Basic oscillator requirements

In selecting an oscillator, the user will be most interested in its frequency coverage. The question to be answered here is, "Will the instrument supply both the lowest and highest frequencies of interest for anticipated tests?" As shown on the chart, Hewlett-Packard manufactures a broad range of oscillators and function generators covering the frequency spectrum from 0.00005 Hz to 22 MHz.

The user's next concern will be with the available output power or voltage. Some tests require large amounts of power, while others merely require sufficient voltage output. For almost any application, there is a Hewlett-Packard oscillator capable of delivering the desired voltage output into a high-impedance load or of supplying the desired power into lower-impedance loads.

Most Hewlett-Packard oscillators have a low internal impedance. This low impedance can easily be converted to a desired output impedance with a resistive network. This assures a constant impedance over a wide frequency range. In some cases, transformer coupling is used to provide a balanced and isolated output. Some instruments have transformer taps for supplying the wide variety of impedances encountered in normal test work. Since many audio-range oscillators are used with 600-ohm systems, several include 600-ohm adjustable attenuators on the output.

Besides frequency range and power output, the user will be interested in the

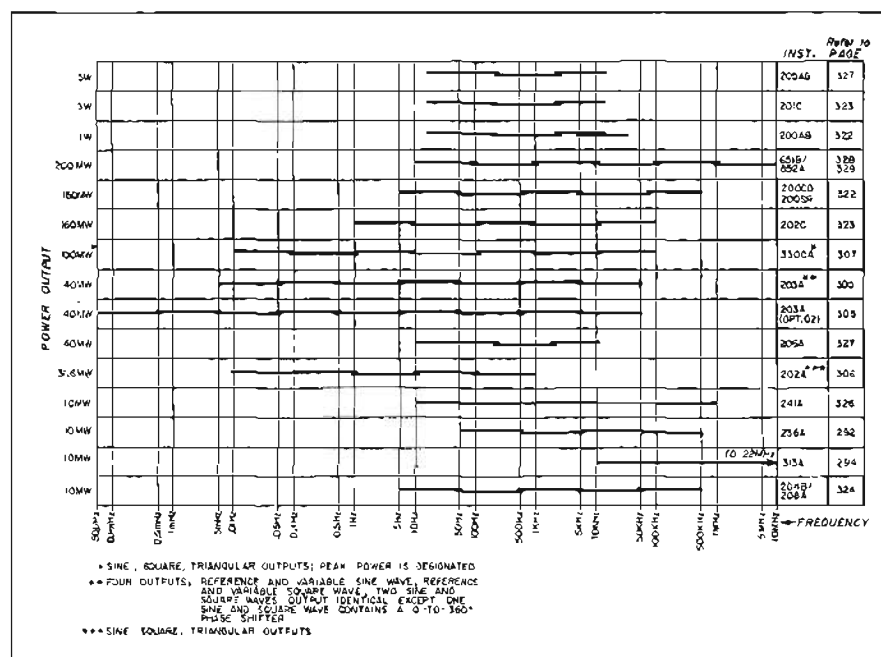

Table 1. Frequency range and power output of HP oscillators. Line segments show span of each range.

oscillator's stability, its dial resolution and the amount of harmonic distortion, hum and noise in the output signal.

### Dial resolution and accuracy

In the ideal case, the user should be able to set the tuning dial of his oscillator to a particular frequency with assurance that the oscillator will deliver that frequency at all times. Most dial accuracies of Hewlett-Packard oscillators are  $\pm 2\%$ . The dials may be precisely set by a vernier control, and the calibration marks are easily read. The accuracy with which the frequency tracks the tuning dial enters into the overall accuracy figure.

### Frequency stability

The frequency stability of the oscillator determines the ability of the instrument to maintain a selected frequency over a period of time. Component aging, power-supply variations and temperature changes all affect stability. The Hewlett-Packard designed RC oscillator circuits, described later, assure stability by using large amounts of negative feedback. Carefully chosen components, such as Hewlett-Packard precision resistors and variable capacitors in the frequency-determining networks, contribute to long-term stability. Oscillator stability is included in the overall 2% dial accuracy figure.

### Amplitude stability

Amplitude stability is important in certain oscillator applications. Amplitude stability is inherent in the Hewlett-Packard RC oscillator circuit because of the large negative feedback factor and the amplitude stabilizing techniques. The "frequency response," or amplitude variation as the frequency is changed, is of special interest when the oscillator is used for response measurements throughout a wide range of frequencies.

### Distortion

Distortion in the oscillator's output signal is an inverse measure of the purity of the oscillator's waveform. Distortion is undesirable in that a harmonic of the test signal may feed through the circuits under test, generating a false indication at the output. If the oscillator is used for distortion measurements, the amount of distortion that it contributes to the measurements should be far less than that contributed by the circuits under test.

The Hewlett-Packard Wien bridge RC oscillator is a low-distortion, sine-wave generator; all Hewlett-Packard Wien bridge oscillators have less than 1% distortion (typically 0.25%). Where 0.25% distortion may be too large, a selective amplifier following the oscillator will reduce this to less than 0.1%. A tuned,



selective amplifier is used in the HP 206A Low-Distortion, Audio-Signal Generator for this purpose. The 203A Function Generator is another ideal source with low distortion and wide frequency coverage. See page 305, Function Generators.

### Hum and noise

Hum and noise can be introduced at a variety of points in oscillator circuits; but when the circuit operates at a relatively high level, the amount of hum and noise introduced into the device under test is usually negligible. Hum and noise introduced by a power amplifier usually remain constant as the output signal amplitude is diminished. Hence, even though the hum and noise power may be quite small compared to the rated output, these spurious signals sometimes become a significant portion of low-level output signals. To overcome such a limitation, many Hewlett-Packard oscillators have their amplitude control on the output side of the power amplifier so that hum and noise are reduced proportionally with the signal when low-level signals are desired for test purposes.

### Theory of operation

The Wien bridge RC oscillator has become the standard oscillator circuit for adjustable frequency test signals. These oscillators are far less cumbersome than the LC types and far more stable than the beat-frequency types formerly used for the below-rf range.

The basic Hewlett-Packard Wien bridge oscillator circuit, shown in Figure 1, is a two-stage amplifier with both negative and positive feedback loops. Posi-

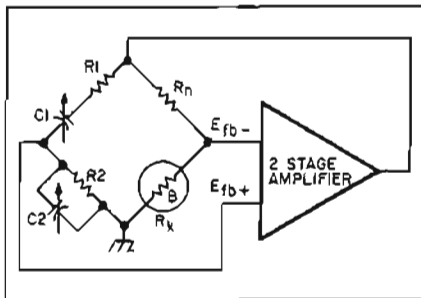

Figure 1. Basic HP Wien bridge RC oscillator circuit.

itive feedback for sustaining oscillations is applied through the frequency selective network,  $R_1C_1-R_2C_2$ , of the Wien bridge.

The amplitude and phase characteristics of the network, with respect to its driving voltage, are shown in Figure 2. These

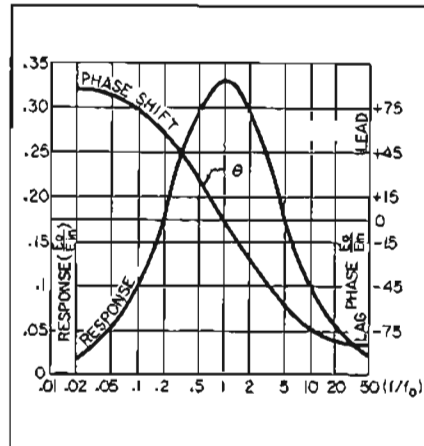

Figure 2. Characteristics of frequency-determining network.

curves show the amplitude response is maximum at the same frequency at which the phase shift through the network is zero. Oscillations are therefore sustained at this frequency. The resonant frequency,  $f_n$ , is expressed by the equation:

$$f_n = \frac{1}{2\pi RC}, \text{ when } R_1 = R_2 \text{ and } C_1 = C_2.$$

Unlike LC circuits, where the frequency varies inversely with the square root of  $C$ , the frequency of the Wien bridge oscillator varies inversely with  $C$ . Thus, frequency variation greater than 10-to-1 is possible with a single sweep of an air-dielectric tuning capacitor. Range switching usually is accomplished by switching the resistors.

The negative feedback loop involves the other pair of bridge arms,  $R_n$  and  $R_k$ . In a Wien bridge RC oscillator,  $R_k$  is a temperature-sensitive resistor with a positive temperature coefficient. It is an incandescent lamp operated at a temperature level lower than its illumination level. This lamp, being sensitive to the amplitude of the driving signals, adjusts the voltage division ratio of the branch accordingly. Thus, as the amplitude of oscillations increases, the resistance of  $R_k$  increases. The negative feedback also increases, reducing the gain of the amplifier and restoring the amplitude to normal.

The amplitude of oscillations in any oscillator increases because of the positive

feedback until some form of limiting occurs. The Hewlett-Packard Wien bridge RC oscillator depends on the temperature-sensitive resistor for amplitude control. Thus, the amplifier may be operated entirely within the linear portion of its transfer characteristic, resulting in a low-distortion, sinusoidal output.

A different type of amplitude stabilization is used in the solid-state Hewlett-Packard RC oscillators, such as the 204B, 208A, 651B and the 652A. Because the current drawn by a lamp would be incompatible for use with transistors and battery power sources, these instruments use a peak-detector circuit which provides a bias voltage proportional to the oscillator output voltage.

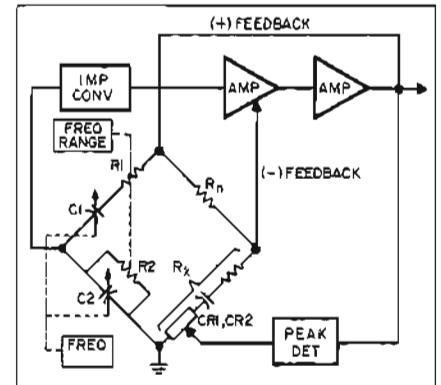

Figure 3. Solid-state RC oscillator.

(See Figure 3). The output of the amplifier is applied to a transistor biased so that it conducts only with the positive peaks of the oscillations. When these positive peaks exceed a set level, a reference diode breaks down, causing a reduction in forward bias of CR1 and CR2. The decrease in forward bias causes the diodes to conduct less, increasing the dynamic resistance of  $R_k$ . The increase in the impedance of  $R_k$  increases the negative feedback, reducing the amplitude of the oscillator output signal.

The Wien bridge RC oscillator is capable of stable oscillations with low distortion output. With the addition of a power amplifier to isolate the oscillator from the load, this circuit is capable of providing useful test signals for a broad variety of purposes. The low-cost HP Model 200AB Oscillator uses such an arrangement.

### Pushbutton tuning

Pushbutton oscillator tuning is possible with a modified Wien bridge, as shown in Figure 4. Here, the resistive branches

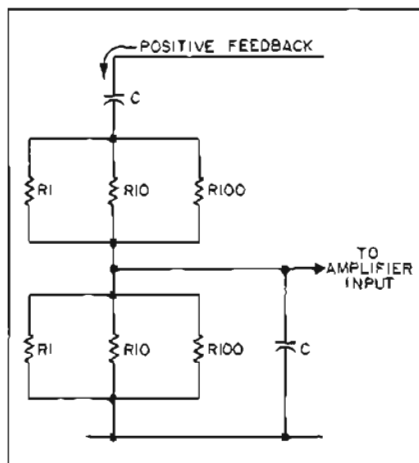

Figure 4. Frequency-selective network for pushbutton oscillator.

of the frequency-selective network are made up of parallel combinations of resistors. The 241A Pushbutton Oscillator has three pushbutton, decade-switch selectors for changing the resistors in the frequency selective network. Each decade selects resistive value for one pair of resistors in the frequency-determining network.

Ranges are switched by changing capacitors with a five-position pushbutton switch. Total frequency range of the 241A Oscillator is from 10 Hz to 1 MHz in 4500 discrete steps. An overlapping vernier control permits setting to intermediate frequencies.

Pushbutton tuning enables the frequency to be changed by precise increments. Frequency selection to three-digit resolution with 1% accuracy and resettability to within 0.02% are possible.

### Balanced RC oscillator

A more refined circuit, the balanced Wien bridge RC oscillator, is shown in Figure 5. This circuit provides several advantages over the basic single-ended

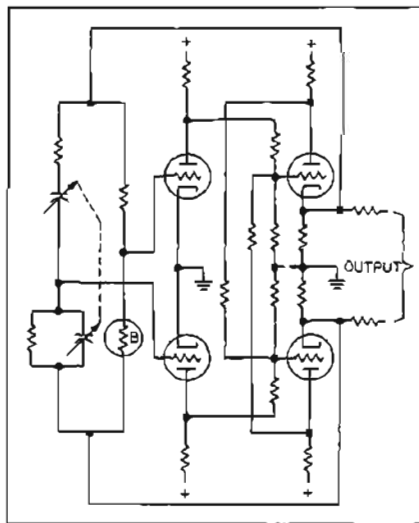

Figure 5. Balanced RC oscillator.

oscillator circuit. One advantage is that the circuit is operating in a balanced mode, which means that balanced output may be obtained directly from the oscillator-cathode followers without use of a transformer.

The circuit has zero-output impedance because of the positive feedback from the plate of each output tube to the control and screen grids of the opposite output tube. Zero output impedance means that the circuit is insensitive to load changes. Positive feedback effectively increases the amplifier gain,  $A$ , to infinity. From the equation,  $Z_o' = Z_o / (1 + A\beta)$ , where  $Z_o'$  is the output impedance without feedback and  $\beta$  is the stabilizing negative feedback factor, it can be seen that the output impedance  $Z_o'$  becomes zero if  $A$  is infinite. Series resistors are inserted in the output leads to present a 600-ohm impedance load and also to prevent short circuiting of the power tubes' cathodes.

In the balanced circuit, no dc passes through the lamp circuit; the lamp current is pure ac. This means that lamp heating occurs at twice the oscillating frequency, enabling the circuit to be operated down to half of the low-frequency limit of the single-ended oscillator. In addition, the capacitor-tuning rotors are near ground potential, reducing leakage effects in these capacitors and permitting larger resistors to be used in the RC circuits for low-frequency operation. This improved circuit is used in the 200CD Wide-Range Oscillator and the 200SR and 202C Low-Frequency Oscillator.

### Special purpose oscillators

The 236A Telephone Test Oscillator was designed to meet specific requirements in the telephone industry covering the frequency range of 50 Hz to 560 kHz. Transformer coupling provides a balanced output with multiple secondary taps for matching to 135, 600 and 900 ohms. The oscillator output is connected to a multiple arrangement of telephone jacks for convenient connection to a switchboard or telephone line. When the function switch is in the dial position, the output jacks are disconnected from the oscillator and connected in parallel to a separate set of jacks to enable the operator to dial a telephone line. After a line is obtained, the function switch is used to disconnect the lineman's headset and place a test signal on the line while holding the dialed connection. The oscillator can be operated from power line or internal battery for field use. Refer to page 292 for additional information.

### High-frequency oscillator

The high-frequency limit of the RC oscillator is imposed by the amplitude

and phase characteristics of the oscillator-amplifier. An amplifier phase shift of just a fraction of a degree causes 1% error in calibration. A modified Wien bridge oscillator is used on all the ranges of the HP 651B, instead of phase-shift oscillators which are commonly used above 100 kHz. This is made possible through the use of a wide-band, transistorized oscillator-amplifier with the phase shift controlled several octaves past the oscillator's upper 10-MHz limit. An impedance converter provides a high impedance in series with the input of a differential amplifier on the first four frequency ranges (X10 to X10 k). The added high impedance prevents the RC bridge circuit from being loaded by the low input impedance of the differential amplifier on lower frequency ranges. The impedance converter is by-passed on the X100 k and X1 M range due to lower resistance values in the RC bridge. A complementary symmetry circuit is used to provide power gain and to increase the dynamic voltage range of the oscillator. The basic circuit of the Hewlett-Packard solid-state 10 Hz to 10 MHz oscillator is shown in Figure 6.

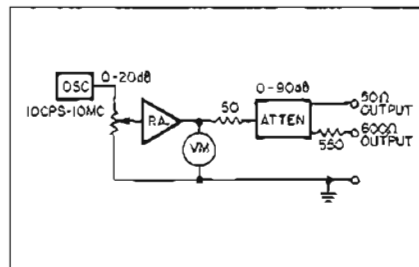

Figure 6. RC high-frequency oscillator.

Another Hewlett-Packard high-frequency oscillator, Model 313A, is a beat-frequency oscillator. The output is derived from mixing a local oscillator frequency of 30 MHz to 52 MHz with a 30-MHz crystal oscillator, resulting in an output frequency of 10 kHz to 22 MHz in one band. This output has an extremely flat frequency response. The 313A has an output attenuator of 109.9 dB adjustable in 10 dB, 1 dB and 0.1 dB steps.

This oscillator is also a tracking generator for the 312A Wave Analyzer.

The oscillator circuits described here are used in Hewlett-Packard's broad line of signal sources. These signal sources span a frequency range of 0.00005 Hz to 22 MHz, encompassing the subsonic, audio, ultrasonic, video and rf ranges. All of the Hewlett-Packard oscillators and test oscillators described in this catalog have been designed with the requirements of a maximum number of applications in mind. The various techniques were chosen in order to maximize the performance offered while minimizing the cost so that a Hewlett-Packard oscillator is available to meet your application.

**SIGNAL SOURCES****AUDIO OSCILLATORS**

Exceptional value, highest quality

Models 200AB, 200CD, 201C

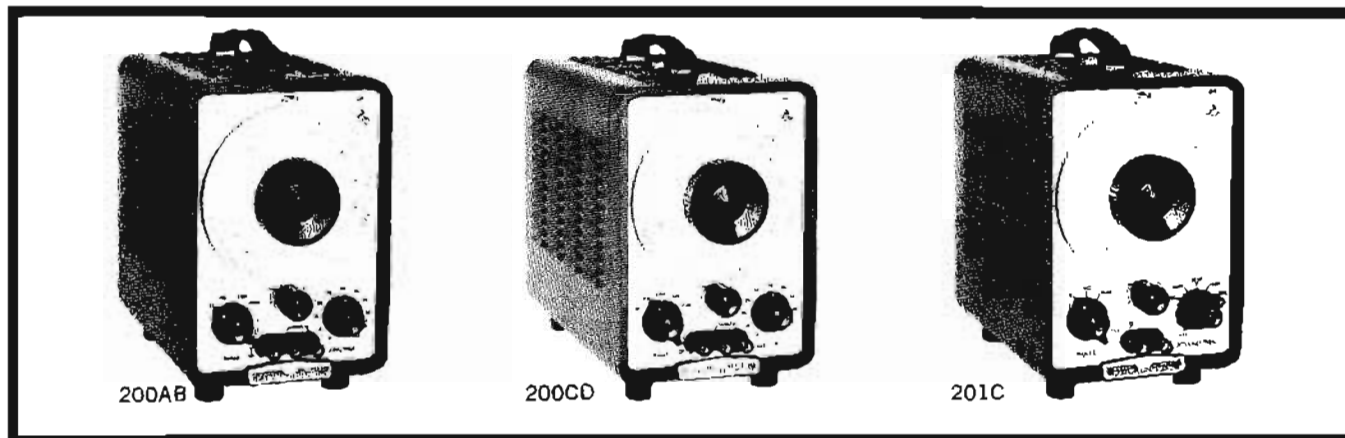
**Features:**

- No zero setting, high stability
- Constant output, low distortion
- Wide frequency range, log scale
- No frequency change with load variation

Hewlett-Packard RC oscillators have long been basic tools for making electrical and electronic measurements of precise accuracy. These world-famous test instruments give you the most compact, dependable, accurate and easy-to-use commercial oscillators available.

The HP 200 Series Oscillators have high stability and accurate, easily resettable tuning circuits. Low-impedance operating levels, together with superior insulation, guarantee peak performance throughout years of trouble-free service. The instruments have wide frequency range and long dial lengths and feature an improved vernier frequency control. Operation is simplified — just three controls are required. Instruments are compact, light in weight and enclosed in a convenient, aluminum case with carrying handle. They occupy minimum bench space and are easily portable. Rack mounting is available on order.

**200AB Audio Oscillator, low cost, 20 Hz to 40 kHz**

This basic oscillator is a compact, convenient source of precision audio test voltages, which is offered at an extremely low price. Frequency coverage is 20 Hz to 40 kHz in four overlapping bands. The 63" effective scale length and 72 dial divisions insure accurate, direct frequency setting. Output is balanced for dependable driving of transmission systems. The 200AB is ideal for amplifier testing, as a bridge voltage source, for testing transmitter modulator response, modulating signal generators and making loudspeaker resonance tests. HP 200AB, \$165 (cabinet); HP 200ABR, \$170 (rack mount).

**200CD Wide-Range Oscillator, multi-purpose, 5 Hz to 600 kHz**

One of the most popular of all HP oscillators, Model 200CD covers the range of 5 Hz to 600 kHz in five overlapping decade bands. Accurate frequency setting is provided

by 85 dial divisions and an effective scale length of 78 inches. A vernier drive allows precise adjustment.

The 200CD gives a maximum sinewave output of at least 10 volts across its rated load of 600 ohms and at least 20 volts open circuit. Its distortion rating is very low, less than 0.2% from 20 Hz to 200 kHz. A special feature of the 200CD is that its waveform purity does not depend on load. The output impedance is nominally 600 ohms. The output transformers are balanced within 0.1% at the lower frequencies and within approximately 1% at the higher frequencies. The 200CD is particularly useful for testing servo and vibration systems, medical and geophysical equipment, audio amplifiers, sonar and ultrasonic apparatus, carrier telephone systems, video frequency circuits, etc. Waveform purity is maintained with extremely low loads. Frequency is covered in 5 decade ranges, and accuracy is  $\pm 2\%$  including warm-up, aging, tube changes, etc. Frequency response is  $\pm 1$  dB full range. HP 200CD, \$195 (cabinet); HP 200CDR, \$200 (rack mount).

The H20-200CD is a standard 200CD modified to have an extremely low distortion output. Refer to the Table of Specifications, page 323. HP H20-200CD, \$250.

**200SR Oscillator, 5 Hz to 600 kHz, 50-ohm output impedance**

The 200SR Oscillator is a rack-mounted instrument identical to the 200CD with the exception of the output circuitry. The output voltage is at least 3 volts rms into a 50-ohm load, continuously variable with 10 dB minimum range. This oscillator, because of its 50-ohm output impedance, may be used for voltage calibration. HP 200SR, \$230 (rack mount).

**201C Audio Oscillator, high power, 20 Hz to 20 kHz**

Particularly designed for amplifier testing, transmission line measurements, loudspeaker testing, frequency comparison and other high fidelity tests, this audio oscillator meets every requirement for speed, simplicity and pure waveform. The frequency range, 20 Hz to 20 kHz, is covered in 3 bands; response is  $\pm 1$  dB full range. Output is 3 watts or 42.5 volts into 600 ohms; an attenuator adjusts output 0

## AUDIO OSCILLATORS

Exceptional value, highest quality  
Models 202C, 200SR



## SIGNAL SOURCES

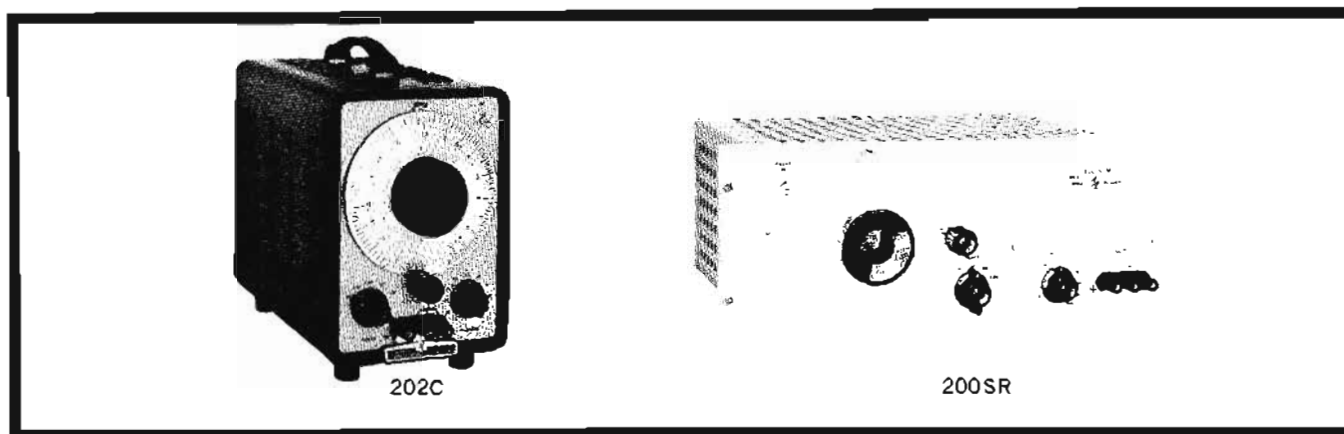

to 40 dB in 10 dB steps and provides either low impedance or constant 600-ohm impedance. Distortion at 1 watt output and above 50 Hz is less than 0.5%. HP 201C, \$250 (cabinet); HP 201CR, \$255 (rack mount).

### 202C Low-Frequency Oscillator, excellent waveform 1 Hz to 100 kHz

Model 202C brings to the low-frequency spectrum the accuracy and stability you associate with audio measurements. It provides excellent waveforms in the subsonic, audio and ultrasonic frequency ranges, and has broad applicability for industrial, field or laboratory use. Specifically, it may be used for these important tests: vibration or stability characteristics of mechanical systems; electrical simulation of

mechanical phenomena; determining electro-cardiograph and electro-encephalograph performance; seismograph response; making vibration checks of structural components; obtaining performance characteristics of geophysical prospecting equipment; making operational checks of servo-mechanism systems and general audio measurements.

The transformer-coupled, balanced output of the Model 202C enables it to meet the signal source requirements for tests of a wide variety of systems. The instrument provides an output of at least 10 volts across its rated load of 600 ohms and at least 20 volts open circuit. A special feature is that waveform purity does not depend upon load. Distortion is less than 0.5%; hum voltage is less than 0.1%, and recovery time is extremely short—5 seconds at 1 Hz. HP 202C, \$325 (cabinet); HP 202CR, \$330 (rack mount).

### Specifications

HP Model	Frequency range	Calibration accuracy	Output to 600 ohms	Output impedance	Maximum distortion	Maximum hum and noise <sup>†</sup>	Input power (watts)	Weight—lb (kg)		Size—Inches (mm)			Price
								net	ship	W	H	D	
200AB	20 Hz to 40 kHz (4 bands)	±2%	1 W (24.5 V)	75 ohms	1% 20 Hz to 20 kHz; 2% 20 kHz to 40 kHz	0.05%	70	15 (5.3)	16 (7.2)	7½ x 11½ x 12 (191 x 292 x 305)		\$165	
200CD	5 Hz to 600 kHz (5 bands)	±2%	160 mW (10 V)	600 ohms	0.2% 20 Hz to 200 kHz; 0.5% 5 Hz to 20 Hz and 200 kHz to 600 kHz	0.1%	90	22 (9.9)	24 (10.8)	7¾ x 11½ x 14¾ (187 x 292 x 365)		\$195	
H20-200CD			7.5 V								**		\$250
200SR	5 Hz to 600 kHz (5 bands)	±2%	3 V into 50 ohms	50 ohms	0.2% 20 Hz to 200 kHz; 0.5% 5 Hz to 20 Hz and 200 kHz to 600 kHz	0.1%	75	25 (11.2)	36 (16.2)	19 x 7 x 12-5/16 (483 x 178 x 313)		\$230	
201C	20 Hz to 20 kHz (3 bands)	±1%	3 W (42.5 V)	600* ohms	0.5% †	0.03%	75	16 (7.2)	19 (8.6)	7½ x 11½ x 12½ (191 x 292 x 318)		\$250	
202C	1 Hz to 100 kHz (5 bands)	±2%	160 mW (10 V)	600 ohms	0.5% §	0.1%	75	27 (12.2)	28 (12.6)	7½ x 11½ x 14¼ (191 x 292 x 362)		\$325	

\* Internal impedance approx. 600 ohms with output attenuator at 10 dB or more, approx. 75 ohms below 5000 Hz with attenuator at zero. † Internal non-operating controls permit precise calibration of each band. ‡ 0.5% , 50 Hz to 20 kHz at 1 watt output; 1% over full range at 3 watts output. § Above 5 Hz.

\*\* Same as 200CD except: distortion: 0.06% 60 Hz to 50 kHz, 0.1% 20 Hz to 50 kHz and 50 kHz to 400 kHz, 0.5% 5 Hz to 20 Hz and 400 kHz to 600 kHz. Output: 7.5 V into 600 ohm load.

† Measured with respect to full rated output.

### General:

**Frequency response:** flat ±1 dB over instrument range; reference level at 1 kHz.

**Size and weight:** maximum overall size and weights are given for cabinet models; 19" rack models also available.

**Power:** 115 or 230 volts ±10% at 50 to 1000 Hz

**Accessories available:** 11000A Cable Assembly, \$4.50; 11001A Cable Assembly, \$5.50; 11004A, 11005A Line Matching Transformers, see page 330.



## PORTABLE TEST OSCILLATORS

Solid-state, battery-operated, floating output  
Models 204B, 208A

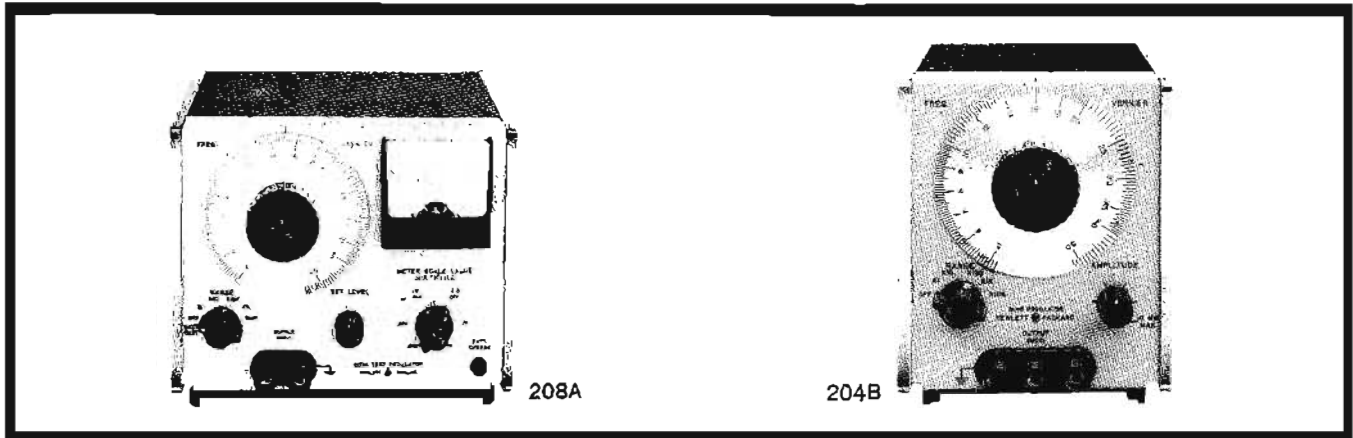

Fully solid-state and battery-operated HP 204B and 208A Oscillators are extremely useful for both field and laboratory work. Internal heat production is small, resulting in unusually low warm-up drift. Stable, accurate signals are instantly available over a frequency range from 5 Hz to 560 kHz.

Balanced and unbalanced loads, plus loads referenced either above or below ground, can be driven by these versatile oscillators; their output is fully floating and isolated from power line ground when battery operated. Completely balanced output is easily obtained with a simple external matching network. There is excellent frequency stability, even with rapidly changing loads; low-impedance circuits drive the 600-ohm output, effectively isolating the oscillator stage.

Figures 1 and 2 show the excellent frequency and amplitude stability characteristics of these oscillators. Typical frequency stability

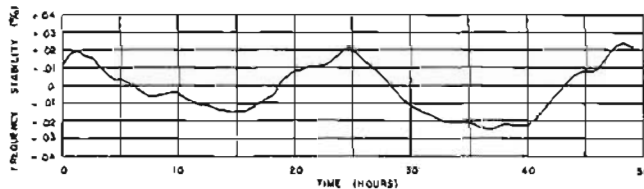

Figure 1. Typical frequency stability characteristics at 500 kHz.

is better than 5 parts in  $10^4$ , even at the highest frequency. Flat frequency response provides further convenience of operation. At all dial and range switch settings the output is flat within  $\pm 3\%$ .

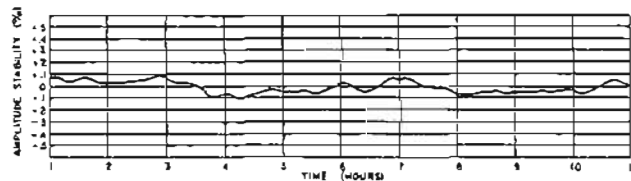

Figure 2. Typical amplitude stability

The solid-state design, light weight, modular construction, and battery operation of these oscillators contribute to their portability. Rapid attenuation selection and monitored oscillator levels ideally suit the 208A Oscillator to transmission line work, production line tests and similar situations, where output levels must be known.

Model 208A is calibrated in volts and has a 6-position attenuator (Meter Scale Value switch) with 10:1 steps from 0.01 mV to 1 V. Another attenuator (Multiplier switch) changes the output by a factor of 2.5, increasing maximum output to 2.5 V rms. The 208A (Option 01) is calibrated in dBm and has a 110 dB attenuator adjustable in 1 dB steps.

### Specifications, 204B

**Frequency range:** 5 Hz to 560 kHz in 5 ranges; 5% overlap between ranges, vernier control.

**Dial accuracy:**  $\pm 3\%$ .

**Frequency response:**  $\pm 3\%$ , with rated load.

**Output impedance:** 600 ohms.

**Output:** 10 mW (2.5 V rms) into 600 ohms; 5 V rms open circuit; completely floating.

**Output control:** continuously variable bridged "T" attenuator with at least 40 dB range.

**Distortion:** less than 1%.

**Noise:** less than 0.05% at maximum output.

**Power:** 4 batteries at 6.75 V each, 7 mA drain, life at least 300 hours.

**Dimensions:** 6-3/32" high, 3 1/2" wide, 8" deep (155 x 130 x 203 mm).

**Weight:** net 7 lbs (3 kg); shipping 8 lbs (3.6 kg).

**Price:** HP 204B (with mercury batteries), \$315.

#### Options

01. AC power supply installed in lieu of batteries, add \$35.

02. Up to 40 hours' operation per recharge with furnished rechargeable batteries (self-contained recharging circuit functions automatically when instrument is connected to ac line; 115 or 230 V  $\pm 10\%$ , 50 to 1000 Hz, approx. 3 W); oscillator may be used during recharge from ac line; expected battery life 20,000 hours, add \$75.

### Specifications, 208A

(Same as 204B, except:)

**Output attenuator:** meter scale value, 0.01 mV to 1 V full scale in 6 steps; X2.5 multiplier, concentric with Meter Scale Value switch, to obtain 0.025 mV to 2.5 V.

**Output attenuator accuracy:** 5 Hz to 100 kHz, error is less than  $\pm 3\%$  at any step; from 100 kHz to 560 kHz, error is less than 5% at any step; specifications include multiplier accuracy.

**Output monitor:** solid-state voltmeter monitors level at input to attenuator and after set level; accuracy  $\pm 2\%$  of full scale into 600 ohms.

**Set level:** continuously variable bridged "T" attenuator with 10:1 voltage range.

**Operating temperature range:** 0°C to +50°C.

**Power:** up to 30 hours' operation per recharge with furnished rechargeable batteries (self-contained recharging circuit functions automatically when instrument is connected to ac line; 115 or 230 V  $\pm 10\%$ , 50 to 1000 Hz, approx. 3 W); oscillator may be used during recharge from ac line; expected battery life, 20,000 hours.

**Dimensions:** 6-3/32" high, 7-25/32" wide, 8" deep (155 x 198 x 203 mm).

**Weight:** net 8 1/4 lbs (3.5 kg); shipping, approximately 11 lbs (5 kg).

**Price:** HP 208A, \$525.

### Specifications, 208A (Option 01.)

(Same as 208A, except:)

**Output attenuator:** 0 to 110 dB in 1 dB steps.

**Accuracy, 10 dB section:** from 5 Hz to 100 kHz, error is less than  $\pm 0.125$  dB at any step; from 100 kHz to 560 kHz, error is less than  $\pm 0.25$  dB at any step.

**Accuracy, 100 dB section:** from 5 Hz to 100 kHz error is less than  $\pm 0.25$  dB at any step; from 100 kHz to 560 kHz, error is less than  $\pm 0.5$  dB at any step.

**Output monitor:** solid-state voltmeter monitors level at input to attenuator, and after set level; scale calibrated -10 dBm to -11 dBm; accuracy  $\pm 0.25$  dB at +10 dBm into 600 ohms.

**Set level:** continuously variable bridged "T" attenuator with 20 dB minimum range.

**Price:** HP 208A (Option 01.), \$535.

## DIGITAL OSCILLATOR

Four digit frequency resolution, 10 Hz to 1 MHz  
Model 4204A



## SIGNAL SOURCES

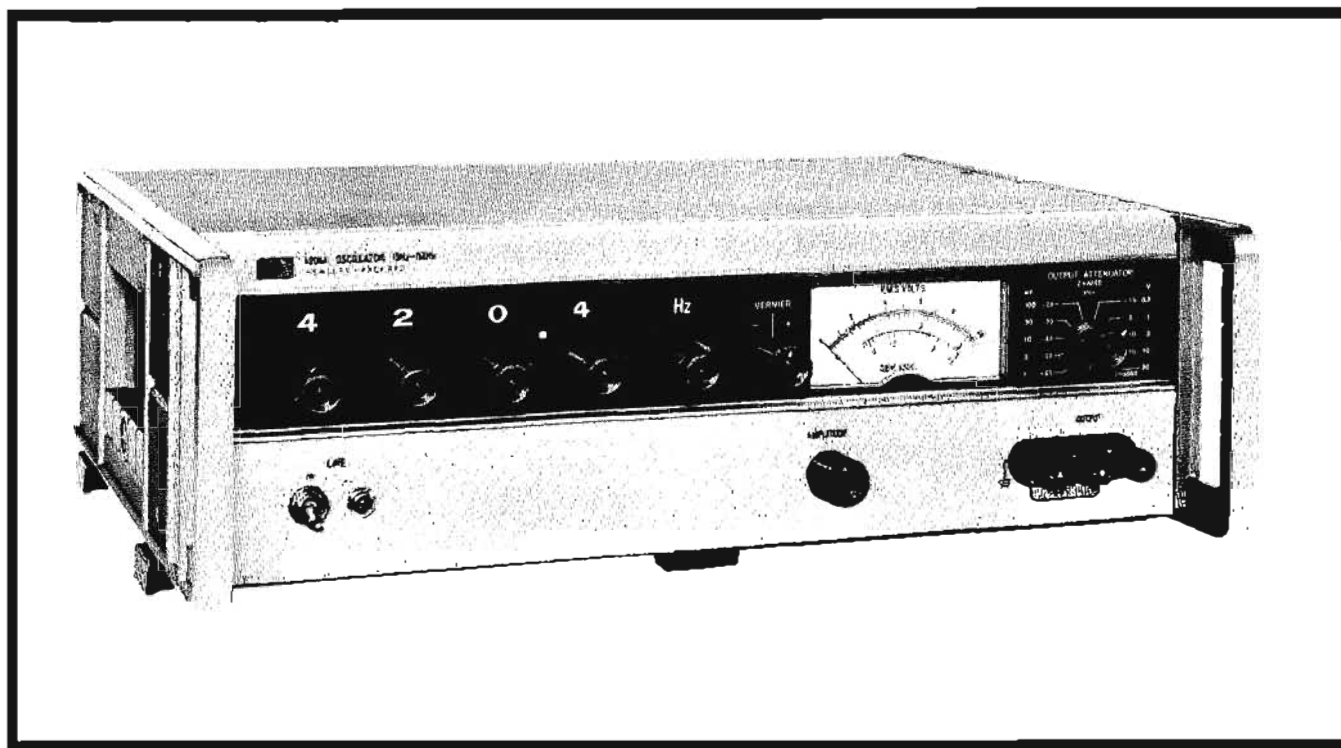

### Advantages:

- Simple, rapid 0.2% frequency selection
- Flat frequency response, 10 Hz to 1 MHz
- 0.01% frequency repeatability
- Excellent stability

### Uses:

- Production line and repetitive testing
- Standard source for calibrating ac to dc converters
- Response testing of wide or narrow band devices
- Filter checkout

The HP 4204A Digital Oscillator provides accurate, stable test signals for both laboratory and production work. This one instrument does the jobs of an audio oscillator, and ac

voltmeter, and an electronic counter, in applications requiring an accurate frequency source of known amplitude.

Any frequency between 10.00 Hz and 999.9 kHz can be digitally selected with an in-line rotary switch, to four significant figures. As many as 36,900 discrete frequencies are available. Infinite resolution is provided by one vernier control, which also extends the upper frequency limit to 1 MHz. Frequency accuracy is better than  $\pm 0.2\%$  and repeatability is typically better than  $\pm 0.01\%$ .

A built-in high impedance voltmeter measures the output. The meter is calibrated to read volts or dBm into a matched 600 ohm load. (0 dBm = 1 mW into 600 ohms.) The output attenuator has an 80 dB range, adjustable in 10 dB steps with a 20 dB vernier. Maximum output power can be increased to 10 volts (22 dBm) into 600 ohms.

### Specifications

**Frequency range:** 10 Hz to 1 MHz, 4 ranges.

**Frequency accuracy:**  $\pm 0.2\%$  or  $\pm 0.1$  Hz (at 25°C).

**Frequency stability:**

$\pm 10\%$  line voltage variation: Less than  $\pm 0.01\%$ .

Change of frequency with temperature:  $< \pm 100$  ppm/°C.

**Frequency response:** flat within  $\pm 3\%$ .

**Output:** 10 V (22 dBm) into 600 ohms, (160 mW). 20 V Open Circuit.

**Output attenuator** 80 dB in 10 dB steps;  $< \pm 0.5$  db error.

**Distortion:** less than 0.3%, 30 Hz to 100 kHz. Less than 1%, 10 Hz to 1 MHz.

**Hum and noise:** less than 0.05% of output.

**Dimensions:** cabinet; 5 $\frac{1}{4}$ " high, 16 $\frac{3}{4}$ " wide, 11 $\frac{1}{4}$ " deep. (134 x 426 x 286 mm).

**Power:** 115 V/230 V switch,  $\pm 10\%$ , 10 watts, 50 to 60 Hz.

**Weight:** net, 19 lbs (8.5 kg); shipping, 28 lbs (11 kg).

**Price:** on request.

Manufactured by Yokogawa-Hewlett-Packard Ltd., Tokyo.





## PUSHBUTTON OSCILLATOR

Three-digit frequency resolution, 10 Hz to 1 MHz  
Model 241A

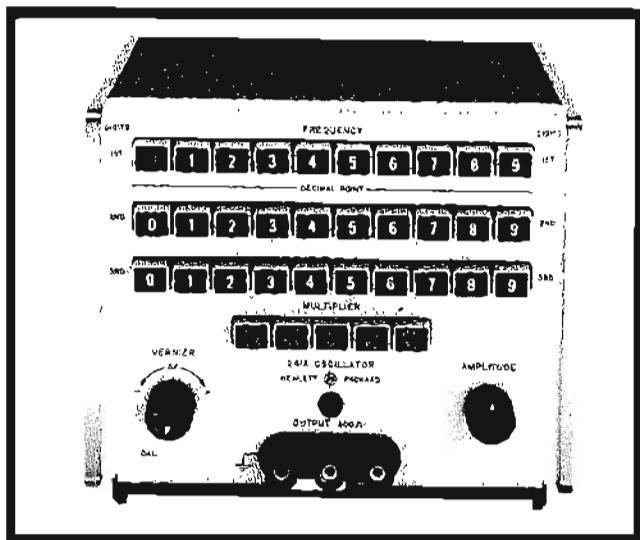

### Features:

- Three-digit frequency resolution
- Simple, rapid, accurate frequency selection
- Compact, lightweight, portable
- Flat frequency response, 10 Hz to 1 MHz
- Accurate repeatability

### Uses:

- Production line and repetitive testing
- Standard source for calibrating ac-to-dc converters
- Response testing at audio and communication frequencies; narrow- or wideband devices
- Low distortion source in the presence of shock, vibration or hf radiation.

The solid-state HP Model 241A Pushbutton Oscillator provides accurate, stable test signals for laboratory or production measurements.

Any frequency between 10 Hz and 999 kHz can be selected to three significant figures by simply pushing the three appropriate frequency pushbuttons and one of five decade multipliers. These pushbuttons control 900 base frequencies in increments of 0.1 Hz from 10.0 to 99.9 Hz, providing 4500 discrete frequency settings. Infinite resolution is provided by a vernier control, extending the upper frequency to 1 MHz.

Since each discrete frequency setting is a digital function effectively isolated from every other setting, a high degree of calibration dependability is achieved — a major advantage for user convenience. Accuracy is within  $\pm 1\%$  of selected value on any range.

Frequency response is flat  $\pm 2\%$  over the entire range at any attenuator setting. This is obtained by using special, fixed-precision resistors and large amounts of negative feedback in a unique biased-diode control circuit. A front-panel control adjusts the bridged-tee attenuator for output levels of  $-30$  dBm to  $+10$  dBm presenting a constant output impedance of 600 ohms. The attenuator, capacitively de-

coupled from the amplifier circuit, eliminates the need for a dc balance adjustment at the output.

Hum and noise are reduced below 0.05% of the output by the use of low-impedance, solid-state circuitry, shielded power supply transformer, and floating output. These features not only isolate the oscillator from stray field pickup, but also allow the oscillator's use in environments where test setups themselves are subject to pickup. The solid-state design, which contributes to superior stability, inhibits the effect of shock or vibration that is often present in test areas. Instabilities in both frequency and amplitude are virtually eliminated in the solid-state circuitry and fixed tuning elements. During the first two hours the frequency stability at 100 Hz is better than .01%, and at 100 kHz the frequency stability is approximately .02% after initial turn-on. Once warmed up, and in normal laboratory environment where ambient temperature does not change more than 3 or 4 degrees Centigrade over a 24-hour period, the frequency stability is typically better than .04% from day to day.

### Convenience - Versatility

The 241A's clean design, functional utility, and lightweight modular construction contribute to its easy portability. Instant frequency selection, lack of tedious dial interpolation, and elimination of frequency ambiguity ideally suit the oscillator to production line work or similar situations where repetitive measurements are made. Here, the frequency repeatability, which is typically better than 0.01%, enables measurements to be made quickly without sacrificing accuracy. And the ability to make a positive accurate frequency selection eliminates the need for any separate frequency indicator; consequently, test procedure is simplified, since a frequency check is unnecessary.

Careful attention to human engineering has resulted in highly visible rectangular pushbuttons for reduction of user fatigue and ease of operation. Frequency ambiguity is prevented by mechanical interlocks inhibiting all but one pushbutton in a given row.

### Specifications

**Frequency range:** 10 Hz to 1 MHz, 5 ranges, 4500 frequency increments per range, with vernier overlap.

**Calibration accuracy:**  $\pm 1\%$ .

**Frequency response:**  $\pm 2\%$  into rated load.

**Output impedance:** 600 ohms.

**Distortion:** 1% maximum.

**Hum and noise:** .05% of output.

**Output:**  $+10$  to  $-30$  dBm into 600 ohms (2.5 volts maximum).

**Power:** 115 or 230 volts, 50 to 1000 Hz, 1 watt.

**Dimensions:** 7-25/32" wide x 6 1/2" high x 8" deep (196 x 166 x 206 mm), 1/2 module.

**Weight:** net 7 3/4 lbs (3.5 kg); shipping 10 lbs (4.5 kg).

**Accessory furnished:** detachable power cord, NEMA plug.

**Price:** HP 241A, \$490.

## AUDIO SIGNAL GENERATORS

Versatile instruments, 20 Hz to 20 kHz  
Models 205AG, 206A



## SIGNAL SOURCES

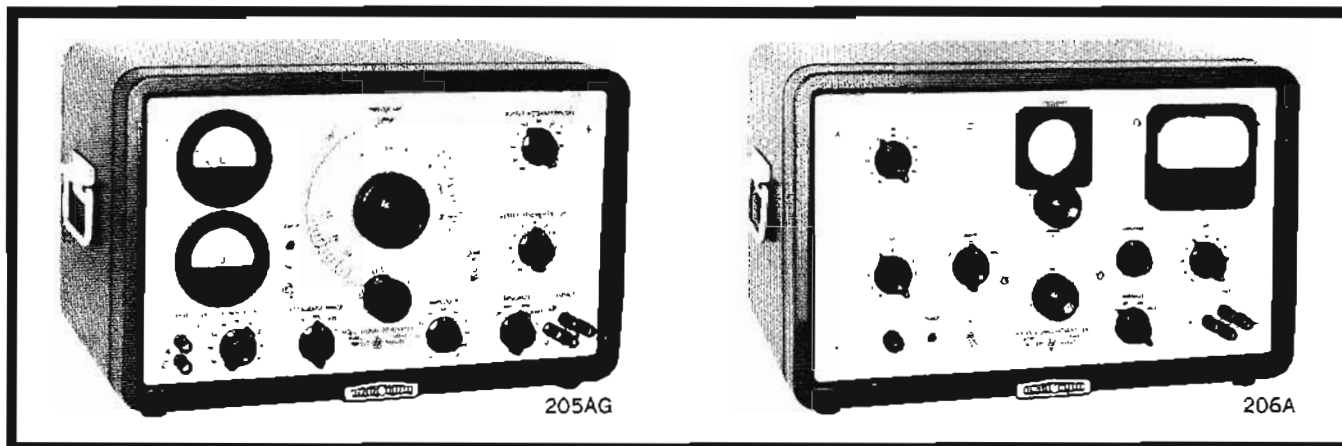

The 205AG Audio Signal Generator materially speeds and simplifies a variety of audio testing jobs where sizable amounts of power are required.

Two voltmeters measure input and output of the device under test. The output level is adjusted by means of the step attenuators, and output impedance can be instantly changed by means of a selector switch to commonly used impedances.

### Specifications, 205AG

**Frequency range:** 20 Hz to 20 kHz in three decade ranges.

**Calibration accuracy:**  $\pm 2\%$  under normal temperature conditions. (Including warm up and changes due to aging of tubes and components).

**Output:** five watts maximum into resistive loads of 50, 200, 600 and 5000 ohms; output circuit is balanced and center-tapped; any terminal may be grounded.

**Frequency response:**  $\pm 1$  dB, 20 Hz to 20 kHz at output levels up to +30 dBm with output meter reading held constant at +37 dB;  $\pm 1.5$  dB, 20 Hz to 20 kHz at output levels above +30 dBm with output meter reading held constant at +37 dB (reference 1000 Hz).

**Internal impedances:** approximately 1/6 of the load impedance with zero attenuator setting; approaches the load impedance with attenuator settings of 20 dB or more.

**Distortion:** less than 1% at frequencies above 30 Hz.

**Hum level:** more than 60 dB below the output voltage or 90 dB below 0 dBm, whichever is the larger.

**Output meter:** calibrated directly in volts at 600 ohms and dBm (0 dBm = 1 mW in 600 ohms); voltage scale: 0 to 65 V, dB scale +20 to +37 dBm.

**Input meter:** calibrated in dBm from -5 to +8 dBm and in volts from 0 to 2 V rms; voltage accuracy is  $\pm 5\%$  of full scale.

**Input attenuator:** extends meter range to +48 dBm and to 200 V rms in 5 dB steps; accuracy  $\pm 0.1$  dB.

**Output attenuator:** 110 dB in 1 dB steps.

**Power:** 115 or 230 volts  $\pm 10\%$ , 50 to 1000 Hz, 150 watts.

**Dimensions:** cabinet: 20 $\frac{3}{4}$ " wide, 12 $\frac{3}{4}$ " high, 15 $\frac{1}{2}$ " deep (527 x 324 x 394 mm); rack mount: 19" wide, 10 $\frac{1}{2}$ " high, 14" deep behind panel (483 x 267 x 356 mm).

**Weight:** net 56 lbs (25,2 kg), shipping 65 lbs (29,3 kg) (cabinet); net 49 lbs (22,1 kg), shipping 63 lbs (28,3 kg) (rack mount).

**Price:** HP 205AG, \$600 (cabinet); HP 205AGR, \$585 (rack mount).

The HP 206A Audio Signal Generator provides a source of continuously variable audio-frequency voltage at a total distortion level of less than 0.1%. This unusually low distortion, coupled with simple, straightforward circuitry, rugged construction and typical HP ease of operation, makes this signal generator ideal for use in the maintenance of FM broadcasting units and high fidelity audio systems.

The 206A Generator includes an output-matching transformer which allows it to be matched to resistive loads of 50, 150, and 600 ohms. This output system is balanced to ground, and each winding is center-tapped. The internal impedance matches the load impedance. A single-ended 600-ohm output is provided which bypasses the line-matching transformer.

### Specifications, 206A

**Frequency range:** 20 Hz to 20 kHz in three decade ranges.

**Calibration accuracy:**  $\pm 2\%$  including warmup drift.

**Output:** +15 dBm into impedances of 50, 150 and 600 ohms; approximately 10 volts are available into an open circuit.

**Output impedances:** the generator has a matched internal impedance, and the selection of output impedances includes 50, 150 and 600 ohms center-tapped and balanced, and 600 ohms single-ended.

**Frequency response:** better than  $\pm 0.2$  dB at all levels, 30 Hz to 15 kHz, when the output meter reading is held constant.

**Distortion:** less than 0.1% at frequencies above 50 Hz and less than 0.25% from 20 Hz to 50 Hz.

**Hum level:** at least 75 dB below the output signal or more than 100 dB below zero level, whichever is larger.

**Output meter:** calibrated in dBm and also in volts; readability at least 0.2 dB at all points above a 50% scale reading (0 dBm equals 1 mW in 600 ohms).

**Output attenuators:** 111 dB in 0.1 dB steps.

**Power:** 115 or 230 volts  $\pm 10\%$ , 50 to 1000 Hz, 140 watts.

**Dimensions:** cabinet: 20 $\frac{3}{4}$ " wide, 12 $\frac{3}{4}$ " high, 15" deep (527 x 324 x 381 mm); rack mount: 19" wide, 10 $\frac{1}{2}$ " high, 14" deep behind panel (483 x 267 x 356 mm).

**Weight:** net 57 lbs (25,6 kg), shipping 66 lbs (29,7 kg) (cabinet); net 50 lbs (22,5 kg), shipping 62 lbs (27,3 kg) (rack mount).

**Price:** HP 206A, \$900 (cabinet); HP 206AR, \$885 (rack mount).



## TEST OSCILLATOR

Solid-state, 10 Hz-10 MHz; 50, 600 $\Omega$  outputs  
Model 651B

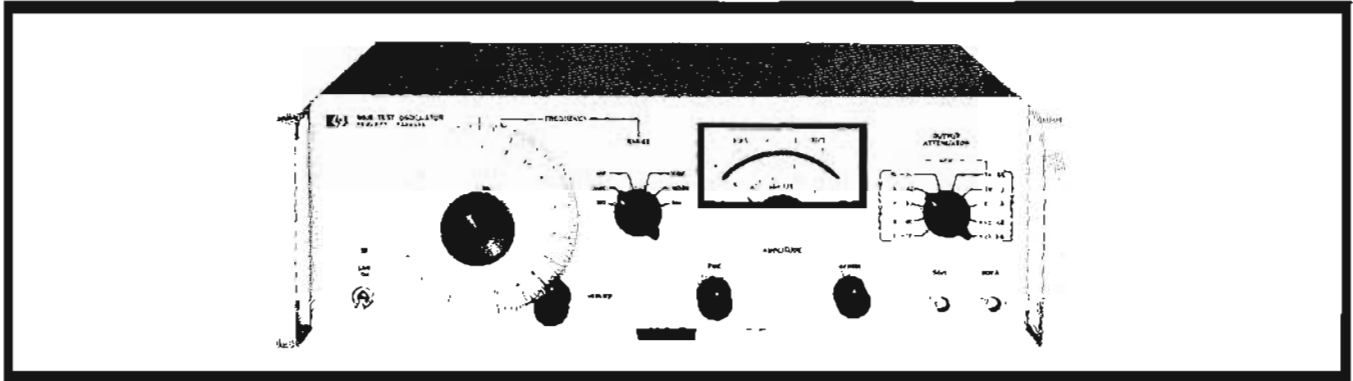

The solid-state HP Model 651B Test Oscillator provides accurate, stable test signals for laboratory or production measurements. This instrument covers a wide frequency range from 10 Hz to 10 MHz continuously variable across six bands.

Two output impedances are available from the front panel, providing 200 mW into 50 $\Omega$  or 16 mW into 600 $\Omega$ . This capacitance-tuned oscillator delivers a flat output throughout the entire frequency range. Once warmed up, and in a normal lab environment where the ambient temperature is relatively constant, the frequency stability at 5 MHz is typically  $\pm 10$  ppm.

An indication of the overall frequency stability under the above conditions is shown in Figure 1, illustrating the behavior over a 15-minute period. The typical frequency stability for a 24-hour period at 5 MHz is  $\pm 0.02\%$ . Frequency stability at lower frequencies is typically better than those shown in the top frequency band.

Typical amplitude stability over a 17-hour period is  $\pm 0.1\%$ , shown in Figure 2.

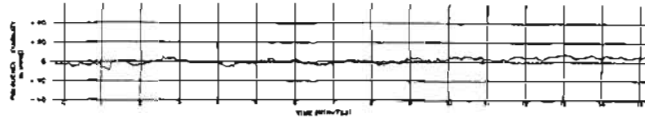

Figure 1. Typical frequency stability characteristics at 5 MHz for 15 minutes.

A voltmeter measures the output of the power amplifier. The meter is calibrated to read V or dBm into a 50 $\Omega$  load. For any attenuator setting, true output is obtained by algebraically adding the attenuator reading and the output volt-

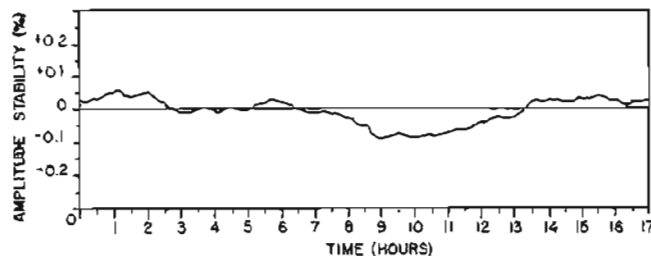

Figure 2. Typical amplitude stability at mid-band frequencies for 17 hours.

meter reading. The output attenuator has a 90 range, adjustable in 10 dB steps with a 20 dB vernier (coarse

\*Other output impedances above 50 $\Omega$  are available on special order.

and fine). Two outputs, 50 and 600 $\Omega$ , are available on the front panel. The standard 651B output monitor is calibrated to read dBm for 50 $\Omega$  (0 dBm = 1 mW into 50 $\Omega$ ). The Model 651B Option 01 is calibrated to read dBm for 600 $\Omega$  (0 dBm = 1 mW into 600 $\Omega$ ). The 651B Option 02 has a 75 $\Omega$  and 600 $\Omega$  output and the monitor is calibrated to read dBm for 75 $\Omega$  (0 dBm = 1 mW into 75 $\Omega$ ). Output impedances not listed are available to meet your requirements. Discuss your application with your Hewlett-Packard sales engineer.

## Specifications

**Frequency range:** 10 Hz to 10 MHz, 6 bands; dial calibration, 1 to 10.

**Dial accuracy:**  $\pm 2\%$ , 100 Hz to 1 MHz;  $\pm 3\%$ , 10 Hz to 10 MHz (including warm-up, drift and  $\pm 10\%$  line variation).

**Output:** 200 mW (3.16 V into 50 $\Omega$ ); 16 mW (3.16 V into 600 $\Omega$ ); 6.32 V open circuit.

**Distortion:**  $< 1\%$ , 10 Hz to 5 MHz;  $< 2\%$  at 10 MHz.

**Hum and noise:** less than 0.05% of maximum rated output.

**Output monitor:** voltmeter monitors level at input of attenuator in volts or dB; top scale calibrated in volts; bottom scale calibrated in dB; accuracy  $\pm 2\%$  at full scale; flatness:  $\pm 1\%$  at full scale, 20 Hz to 4 MHz;  $\pm 2\%$  at full scale, 10 Hz to 10 MHz.

**Frequency response:** flat within  $\pm 2\%$ , 100 Hz to 1 MHz;  $\pm 3\%$ , 10 Hz to 100 Hz;  $\pm 4\%$ , 4 MHz to 10 MHz.

**Amplitude control:** 20 dB range; coarse and fine.

**Attenuator:** range 90 dB in 10 dB steps, overall accuracy,  $\pm 0.1$  dB, 0.3 mV through 3 V ranges;  $\pm 0.2$  dB 0.1 mV range  $Z_o = 50\Omega$  and 600 $\Omega$  (\* $Z_o = 75\Omega$  and 600 $\Omega$ , Option 02).

**Temperature range:** 0 $^{\circ}$ C to +50 $^{\circ}$ C.

**Dimensions:** 16 $\frac{3}{4}$ " wide, 5-7/32" high, 13 $\frac{1}{4}$ " deep (425 x 133 x 367 mm); rack mount kit (5060-0775) furnished with instrument.

**Weight:** net 17 lbs (7.7 kg); shipping 22 lbs (9.9 kg).

**Power:** 115 or 230 V  $\pm 10\%$ , 50 to 1000 Hz, 30 watts.

**Price:** HP 651B, \$590. HP 651B Option 01, output monitor top scale calibrated in dBm/600 $\Omega$ , bottom scale calibrated in volts: \$615. HP 651B Option 02, output, 75 $\Omega$  and 600 $\Omega$ , output monitor top scale calibrated in dBm/75 $\Omega$ , bottom scale calibrated in volts; \$615.

## TEST OSCILLATOR

Make frequency response measurements rapidly  
Model 652A



## SIGNAL SOURCES

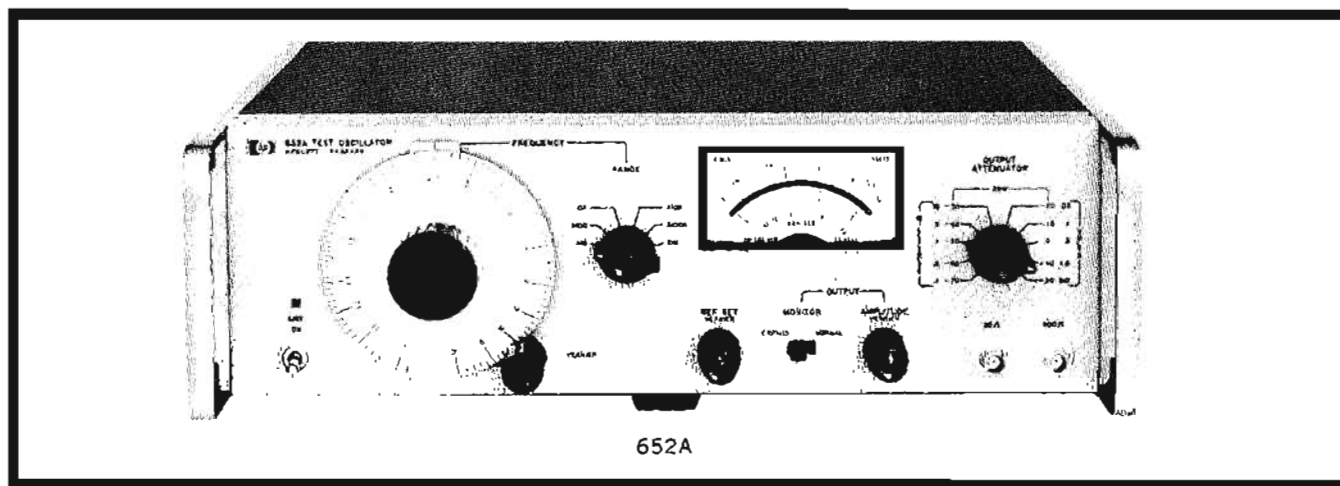

The solid-state HP Model 652A Test Oscillator simplifies frequency response determination by providing a constant amplitude reference voltage of adjustable frequency. Frequency response of voltmeters, oscilloscopes, video amplifiers and filters from 10 Hz to 10 MHz can be quickly and easily measured.

Two output impedances are available from the front panel, providing 200 mW into 50 $\Omega$  or 16 mW into 600 $\Omega$ . This capacitance-tuned oscillator delivers a flat output throughout the entire frequency range. This is obtained by using precision components and peak detector AGC circuitry.

Hum and noise are reduced below 0.05% of the output by use of low impedance, solid-state circuitry, and a shielded power supply transformer. The solid-state design contributes to the 652A's excellent frequency and amplitude stability.

### Output monitor

The HP 652A and HP 651B specifications coincide, except that the 652A offers a different output monitor to make frequency response measurements rapidly with greater resolution.

The monitor is calibrated to read volts or dBm into a matched load when the monitor is in the normal position. True output is obtained by adding the attenuator setting to the output monitor reading.

### X20 expanded scale

The 652A frequency response is  $\pm 0.25\%$  from 10 Hz to 10 MHz when using the EXPAND position of the meter. The monitor meter may only be expanded for voltages between 2.8 to 3.2 volts or from 0.9 volt to 1.0 volt. The expanded meter circuit is located before the output attenuator and any attenuated output from the oscillator will have the same frequency response specification.\*

### Specifications

**Frequency range:** 10 Hz to 10 MHz, 6 bands, dial calibration: 1 to 10.

\* $\pm 0.25\%$  response specification applies for attenuator settings of +20 dB to -50 dB or 3 V through 1 mV.

### Frequency response:

Flat within:  $\pm 2\%$ , 100 Hz to 1 MHz;  $\pm 3\%$ , 10 Hz to 100 Hz;  $\pm 4\%$ , 1 MHz to 10 MHz.\*\*

**Dial accuracy:** (including warmup drift and  $\pm 10\%$  line voltage variation):  $\pm 2\%$ , 100 Hz to 1 MHz;  $\pm 3\%$ , 10 Hz to 100 Hz, 1 MHz to 10 MHz.

**Output:** 200 mW (3.16 V) into 50 $\Omega$ ; 16 mW (3.16 V) into 600 $\Omega$ ; 6.32 V open circuit.

### Attenuator:

Range: 90 dB in 10 dB steps.

Overall accuracy:  $\pm 0.1$  dB, 0.3 mV through 3 V range;  $\pm 0.2$  dB, 0.1 mV range.

**Amplitude control:** 20 dB range nominal (coarse and fine).

**Output monitor:** voltmeter monitors level at input of attenuator in volts or dB. Top scale calibrated in volts. Bottom scale calibrated in dB.

Accuracy:  $\pm 2\%$  at full scale.

Flatness:  $\pm 1\%$  at full scale, 20 Hz to 4 MHz;  $\pm 2\%$  at full scale, 10 Hz to 20 Hz, 4 MHz to 10 MHz.

X20 expanded scale: flatness (from 10 Hz to 10 MHz):  $\pm 0.25\%$  at 25 $^{\circ}$ C  $\pm 10^{\circ}$ , 3 V through 1 mV;  $\pm 0.5\%$  from 0 $^{\circ}$ C to +15 $^{\circ}$ C and +35 $^{\circ}$ C to +50 $^{\circ}$ C.

**Distortion:** less than 1%, 10 Hz to 5 MHz.

**Hum and noise:** less than 0.05% of maximum rated output.

**Temperature range:** 0 $^{\circ}$  to +50 $^{\circ}$ C.

**Power:** 115 V/230 V  $\pm 10\%$ , 50 to 1000 Hz, 30 watts.

**Dimensions:** 5-7/32" high, 16 3/4" wide, 13 1/4" deep (132,6 x 425,6 x 366,8 mm); full module.

**Weight:** net 17 lbs (7,65 kg); shipping 22 lbs (9,9 kg).

**Accessories furnished:** HP 11048B 50 $\Omega$  Feed-thru Termination.

### Accessories available:

HP 738BR Voltmeter Calibrator, \$850.

HP 355C Attenuator, 0 to 12 dB in 1 dB steps, \$150.

**Price:** HP 652A, \$725.

\*\*This specification applies only at 50 $\Omega$  output. The response above 1 MHz at the 600 $\Omega$  output is affected by capacitive loads.

## SIGNAL SOURCES



## ATTENUATORS, ACCESSORIES

Match 600, 500 or 135-ohm lines

Models 350C,D; 11004A, 11005A

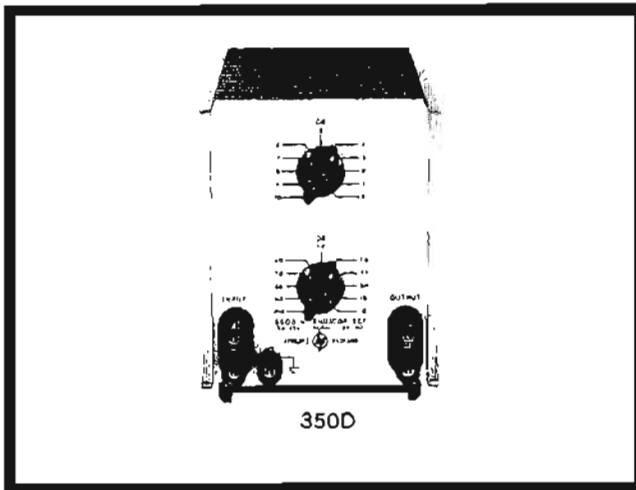

When a high order of accuracy, wide frequency response, large power-handling capacity or special features are required, HP 350 Series Attenuators are of great value and convenience. They are particularly useful in attenuating output of audio and ultrasonic oscillators, measuring gain and frequency response of amplifiers, measuring transmission loss and increasing the scope and usefulness of other laboratory equipment.

### Specifications

**Attenuation:** 110 dB in 1 dB steps.

**Accuracy:** 10 dB section: from dc to 100 kHz, error is  $< \pm 0.125$  dB at any step. From 100 kHz to 1 MHz, error is  $< \pm 0.25$  dB at any step.

**Accuracy:** 100 dB section: from dc to 100 kHz, error is  $< \pm 0.25$  dB at any step up to 70 dB;  $< \pm 0.5$  dB above 70 dB. From 100 kHz to 1 MHz, error is  $< \pm 0.5$  dB at any step up to 70 dB;  $< \pm 0.75$  dB above 70 dB.

**Power capacity:** 350C, 500 ohms; 5 W (50 Vdc or rms) maximum, continuous duty. 350D, 600 ohms; 5 W (55 Vdc or rms) maximum, continuous duty.

**DC Isolation:** signal ground may be  $\pm 500$  Vdc from external chassis.

**Dimensions:** 5 1/8" wide, 6-3/32" high, 8" deep (130 x 155 x 203 mm).

**Weight:** net 3 lbs (1,4 kg); shipping 5 lbs (2,3 kg).

**Accessories available:** HP 11000A Cable Assembly, 44" of RG-58C/U 50 $\Omega$  coaxial cable terminated by dual banana plugs, \$4.50. HP 11001A Cable Assembly, as above but with one BNC male connector, \$5.50.

**Price:** HP 350C; 500 $\Omega$  attenuator, \$125. HP 350D; 600 $\Omega$  attenuator, \$125.

### Oscillator Accessories

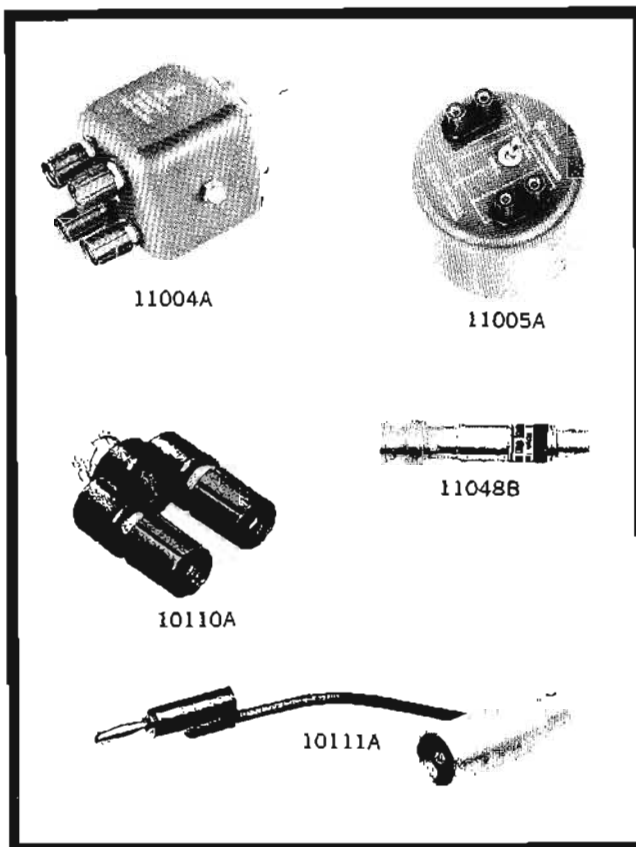

#### 11004A Line-Matching Transformer

The 11004A Transformer, with a frequency response between 5 kHz and 600 kHz, provides fully balanced 135 or 600 $\Omega$  output from single-ended input. Maximum level +22 dBm. HP 11004A, \$60.

#### 11005A Line-Matching Transformer

The 11005A Transformer, with a frequency response between 20 Hz and 45 kHz, provides a fully balanced 600 $\Omega$  output from single-ended input. Maximum level is +15 dBm. HP 11005A, \$80.

#### 10110A, 10111A BNC-to-Binding-Post Adapters

These adapters mate with a BNC or binding post receptacle, respectively, and provide either binding post or BNC output connectors. The 10110A is a BNC male-to-binding-post adapter; the 10111A is a BNC female-to-banana-plug adapter. Spacing between binding posts is 3/4". HP 10110A, \$5; HP 10111A, \$7.

#### 11048B 50-Ohm Feed Thru

Precision 50 $\Omega$  feed-thru termination for 461A and 462A Amplifiers with male and female connectors. HP 11048B, \$10.

# SIGNAL GENERATORS TO 40 GHz



## SIGNAL SOURCES

Essential to practically all microwave measurement applications is signal generating equipment. This section describes the variety of Hewlett-Packard instruments—signal generators and sources, microwave amplifiers, frequency stabilizing equipment, and special-purpose instruments.

### Signal generators

Hewlett-Packard offers a complete line of easy-to-use hf, vhf, uhf, and shf signal generators, precision instruments covering frequencies between 50 kHz and 50 GHz. Each HP generator incorporates the following:

(1) accurate, direct-reading, frequency calibration

(2) variable output, accurately calibrated and direct reading

(3) constant output impedance, well matched

(4) varied modulation capabilities

(5) low rf leakage

(6) low harmonic content

(7) freedom from spurious or incidental modulation.

This assures utmost convenience and accuracy for all kinds of measurements, including receiver sensitivity, selectivity or rejection, signal-to-noise ratio, gain bandwidth characteristics, conversion gain, antenna gain, transmission line characteristics, as well as for driving bridges, slotted lines, filter networks, etc.

Table 1 lists the individual Hewlett-Packard signal generators and their major characteristics.

### HF to uhf signal generators

These signal generators, including HP 606B, 608E, 608F, and 612A, collectively cover frequencies from 50 kHz to 1.23 GHz and are characterized by extremely low drift and incidental frequency modulation. All may be amplitude (sine, square, pulse) modulated. A feedback loop in the 606B keeps its output and percent modulation constant as frequency is varied. The 608E and 608F also offer level power output resulting in significant time saving as well as operator convenience when the generator is being used to conduct tests at several

Table 1

Model	Frequency range	Characteristics	Page
606B Signal Generator	50 kHz to 65 MHz	output 3 V to 0.1 $\mu$ V, mod. BW dc to 20 kHz, low drift and noise, low incidental FM, low distortion, auxiliary rf output, stabilized phase lock capability	334
608E Signal Generator	10 to 480 MHz	output 1 V to 0.1 $\mu$ V, into 50-ohm load; AM, pulse modulation, direct calibration, leveled power output, aux rf output	336
608F Signal Generator	10 to 455 MHz	output 0.5 V to 0.1 $\mu$ V into 50 ohms, amplitude, pulse modulation, direct calibration, low incidental FM and drift, leveled output, aux rf output, stabilized phase lock capability	336
8708A Synchronizer	50 kHz-455 MHz	Companion lock-box for 606B or 608F permitting 2/107 continuous setability & stability, fm and phase modulation	338
612A Signal Generator	450 to 1230 MHz	output 0.5 V to 0.1 $\mu$ V into 50-ohm load; AM, pulse or square-wave modulation, direct calibration	341
614A Signal Generator	0.8 to 2.1 GHz	output at least 0.5 mW to $-127$ dBm (0.1 $\mu$ V) into 50 ohms, pulse or frequency modulation, direct calibration	344
8614A Signal Generator	0.8 to 2.4 GHz	output $+10$ to $-127$ dBm into 50 ohms, leveled below 0 dBm; internal square-wave; external pulse, AM and FM; auxiliary rf output	342
8614B Signal Source	0.8 to 2.4 GHz	output 15 mW; precision attenuator 130 dB range; internal square-wave, external pulse and FM; auxiliary rf output	342
616B Signal Generator	1.8 to 4.2 GHz	output 1 mW to $-127$ dBm (0.1 $\mu$ V) into 50-ohm load, pulse or frequency modulation, direct calibration	344
8616A Signal Generator	1.8 to 4.5 GHz	output $+3$ to $-127$ dBm into 50 ohms, leveled below 0 dBm; internal square-wave, external pulse, AM and FM; auxiliary rf output	342
8616B Signal Source	1.8 to 4.5 GHz	output 3 mW; precision attenuator 130 dB range; internal square-wave, external pulse and FM; auxiliary rf output	342
618C Signal Generator	3.8 to 7.6 GHz	output 1 mW to $-127$ dBm (0.1 $\mu$ V) into 50 ohms, pulse, frequency or square-wave modulation, direct calibration, ext FM and pulse modulation, auxiliary rf output	346
620B Signal Generator	7 to 11 GHz	output 1 mW to $-127$ dBm (0.1 $\mu$ V) into 50 ohms, pulse, frequency or square-wave modulation, direct calibration, ext FM and pulse modulation, auxiliary rf output	346
626A Signal Generator	10 to 15.5 GHz	output $+10$ dBm to $-90$ dBm; pulse, frequency or square-wave modulation, direct calibration	348
628A Signal Generator	15 to 21 GHz	output $+10$ dBm to $-90$ dBm; pulse, frequency or square-wave modulation, direct calibration	348
938A Frequency Doubler	18 to 26.5 GHz	driven by 9 to 13.25 GHz source, HP 626A, 8690A,B or klystrons; 100 dB precision attenuator	350
940A Frequency Doubler	26.5 to 40 GHz	driven by 13.25 to 20 GHz source, HP 628A, 8690A or klystrons; 100 dB precision attenuator	350

## SIGNAL SOURCES



## SIGNAL GENERATORS TO 40 GHz CONTINUED

frequencies. The 606B, 608E, and 608F offer an auxiliary rf output. This fixed-level CW signal can be applied to an HP 5245L Counter for very accurate indication of carrier frequency.

### Stabilized rf signal generation

The HP 606B and 608F contain voltage variable capacitors in their oscillator tank circuit enabling phase-locked operation with the HP Model 8708A RF Lock Box obtaining  $2/10^7$  setability and stability. Phase-locked operation of the HP 606B and 608F Signal Generators can be obtained without compromise of the instruments' modulation or attenuation characteristics while phase-locked. The HP 8708A Synchronizer enables continuous tuning between lock points, permitting continuous frequency response examination of devices such as highly-selective, steep-skirt, narrow-band filters. The HP 8708A Synchronizer provides the additional benefit of phase and frequency modulation capability with the 606B and 608F signal generators.

### Signal sources above 10 MHz

Signal generators available from Hewlett-Packard include general-purpose oscillators and amplifiers, FM signal generators, and specialized signal generators for aircraft navigation systems.

The 3200B VHF Oscillator is a compact, versatile source in the 10 to 500 MHz range suitable for driving bridges, slotted lines, and general-purpose laboratory work. The 230A Signal Generator Power Amplifier provides a convenient means of obtaining power levels up to 4.5 watts in the 10 to 500 MHz range when operated in conjunction with a signal generator.

HP's FM signal generators offer unusual modulation linearity and stability. The 202H FM-AM Signal Generator operates in the 54 to 216 MHz range and is designed to serve the broadcast FM, vhf-tv, and mobile communications markets. The 202J Telemetry Signal Generator is specifically designed for vhf telemetry and covers the 195 to 270 MHz frequency range. An accessory 207H Inverter provides additional rf and IF coverage when used with either the 202H or 202J Signal Generators.

The 211A Signal Generator is specifically designed for the testing and



calibration of aircraft VOR omni-range and ILS localizer receivers; an external modulator, such as the Collins 479-F3, is required to provide simulated course and bearing. The 232A Glide Slope Signal Generator is specifically designed for the testing and calibration of ILS glide slope receivers. The 8925A DME/ATC Test Set is designed to provide complete facilities for the testing and calibration of aircraft DME radios and ATC transponders; suitable external modulators are required, such as the Collins 578D-1 and 578X-1, to simulate ground station operation.

### UHF to shf signal generators and sources

This group of instruments, covering 800 MHz to 21 GHz, features extremely simple operation. The 614A, 616B, 618C, 620B, 626A and 628A Signal Generators provide large, direct-reading frequency and attenuator dials. They may be pulse, square-wave, and frequency modulated. Their versatility makes them useful for measuring signal-to-noise ratio, receiver sensitivity, swr and transmission line characteristics.

The HP 8614A and 8616A Signal Generators are particularly easy to use. Frequency and attenuation are set on direct-reading digital dials, and push-buttons permit fast, easy selection of function (cw, square-wave modulation or external amplitude, pulse or frequency modulation). Leveled output enables frequency response testing without time-consuming readjustment of the generator at each new frequency. Each unit contains a unique PIN diode modulator

which permits such a wide range of amplitude modulation that remote control of output level or precise leveling with external equipment is possible.

The 8614B and 8616B Signal Sources can be used in many applications previously requiring signal generators. The sources have precision attenuators for relative measurements such as insertion loss, and they have pulse and square-wave capability.

### Frequency doublers

Broadband frequency doublers, HP 938A and 940A, provide low-cost signal generator capability in the 18 to 40 GHz range. Designed to be driven by signal sources in the 9 to 20 GHz range, the frequency doublers preserve the versatility and stability of the driving source. Thus, the signals may be cw, pulsed or swept. An output monitor and precision attenuator provide a metered output, even though the input signal is uncalibrated.

In addition to the HP models listed here, the Dymec Division manufactures several rf test sets; each one consists of a signal generator, frequency meter and power meter. Thus, a complete testing system is available in one unit for checking communication and radar systems. Details are given on page 351.

### Stabilized microwave signal generation

The HP Model 8614A/B, 8616A/B, 618C and 620B provide high-level, uncalibrated rf outputs enabling stabilized-microwave signal generation when used with an oscillator synchronizer such as



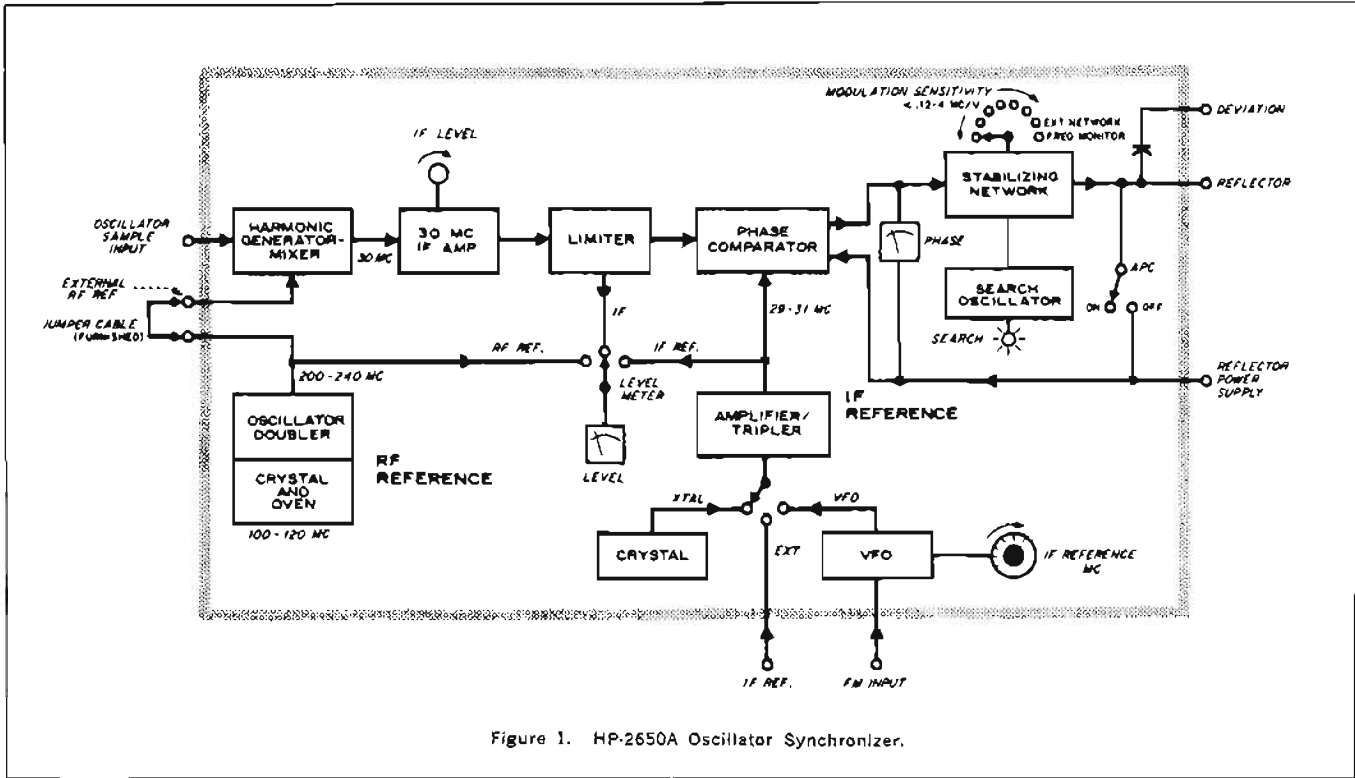

Figure 1. HP-2650A Oscillator Synchronizer.

the 2650A Oscillator Synchronizer or 2654A Frequency Standard Synchronizer. Both instruments employ automatic phase control techniques to provide signal stability essentially equal to that of an internal or external crystal reference.

Applications requiring extremely stable signals include doppler systems, radio astronomy receivers, microwave spectroscopy and parametric amplifier pumps.

Swept-frequency, stabilized rf sources are also available.

Figure 1 shows the functional diagram of the 2650A. The 2654A is similar, the major variations being in the rf and IF reference section to accommodate the external reference, and the elimination of the VFO.

The 2650A incorporates an internal reference oscillator, while the 2654A works in conjunction with a packaged quartz oscillator such as the HP 107BR (page 538). Both synchronizers are fully compatible with HP 8614A,B, 8616A,B, 618C and 620B Signal Generators. The synchronizers introduce no frequency error. Standard instruments will stabilize most reflex klystrons, 1 to 12.4 GHz, with complete elimination of klystron drift and minimization of incidental FM caused by klystron noise, power supply ripple and mechanical shock. Modified versions and cascaded instruments allow operation from 0.1 to 40 GHz.

The 2650A is essentially a crystal-controlled superheterodyne receiver terminating in a phase comparator. A sample of the signal frequency is mixed with harmonics of the rf reference to produce an intermediate frequency of 30 MHz, which is compared in phase with the 30 MHz reference. For stabilizing a klystron, the resultant phase error voltage is added in series with the klystron reflector power supply voltage.

The rf reference frequency is controlled by a quartz crystal, oven-mounted for temperature stabilization, operating at a frequency between 100 and 120 MHz. The harmonics of the internal reference are spaced between 200 and 240 MHz apart, depending on the crystal selected. For each harmonic there are two "lock" frequencies, one 30 MHz above the har-

monic and the other 30 MHz below. A number of lock points are therefore available for a given crystal. As an example, a 100 MHz crystal produces 42 available lock frequencies between 8.2 and 12.4 GHz (X-band).

The signal frequencies at which locking will occur with a particular crystal are given by the formula:

$$F_{\text{EXTERNAL}} = 2NF_{\text{INTERNAL}} \pm F_{\text{IF}}$$

Where  $F_{\text{INTERNAL}} = 100$  to  $120$  MHz (as specified)

$F_{\text{IF}} = 30$  MHz (fixed) or 29 to 31 MHz (variable)

$N =$  harmonic number (5 through 62)

Detailed specifications of the 2650A and 2654A, and information on systems formed from these instruments are listed on page 345.

### Special purpose signal sources

Application	Frequency range	Modulation	Output	Model	Page
Down converter for 202H 202J	100 kHz to 55 MHz	See specifications		207H	355
Test, calibrate FM receivers	54 to 216 MHz	FM, AM	0.2 V	202H	353
Telemetry tests	195 to 270 MHz	FM, AM	0.2 V	202J	354
VOR/ILS tests	88 to 140 MHz	AM	0.2 V	211A	358
ILS tests	329.3 to 335 MHz	AM	0.2 V	232A	358
DME/ATC tests	962 to 1213 MHz	Pulse	-10 dBm	8925A	356
Receiver, Transmitter Tests	5280 to 7780 MHz <sup>1</sup>	FM, AM	1 mW	623B	351
	7100 to 8500 MHz	FM, AM	31.6 mW	5636	
	8500 to 10,000 MHz	FM, AM	1 mW	624C	

<sup>1</sup>Not continuous coverage, see specifications.



## HF SIGNAL GENERATORS

New convenience and performance 50 kHz-65 MHz

Models 606B, 606A

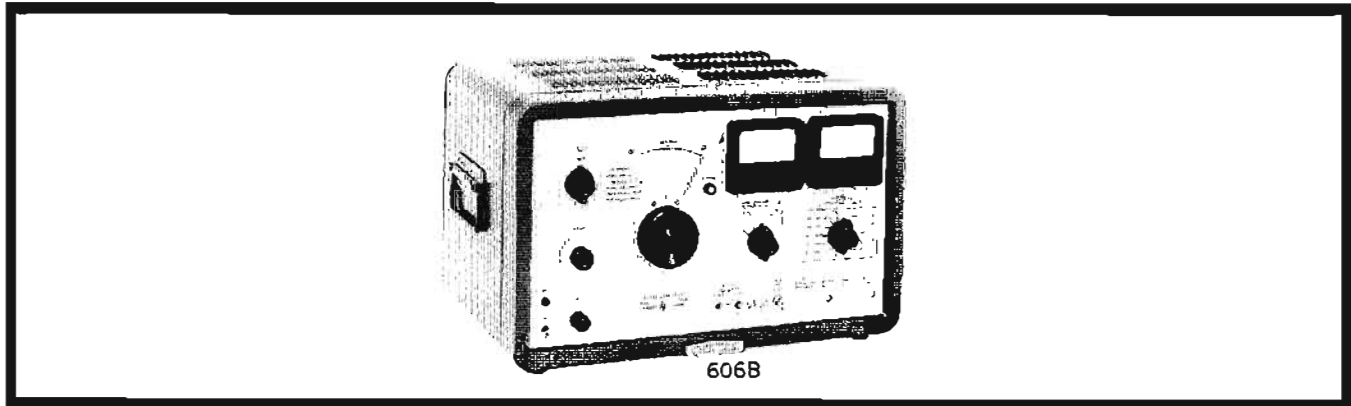

### Description

The Hewlett-Packard 606B Signal Generator provides you with high quality, versatile performance with distinctive ease of operation in the important and widely used 50 kHz to 65 MHz frequency range. Output signals are stable and accurately known, output amplitude can be precisely established over a very wide dynamic range, and versatile modulation capabilities are incorporated to satisfy virtually all measurement requirements. Convenient size and form factor, together with a simple, straightforward control panel layout, make the 606B well suited for production line usage as well as for laboratory or field applications.

### Design

The 606B is a master oscillator-power amplifier (MOPA) design with a broadband buffer amplifier stage between the oscillator and power amplifier circuits for isolation. The MOPA design permits optimization of the oscillator circuit for highest stability including low drift, minimum residual FM, low harmonics, etc., without restricting the modulation characteristics. Modulation is applied to the power amplifier circuit with negligible effect on the oscillator frequency (because of the buffer stage). Very fine frequency settability is achieved through incorporation of a  $\Delta F$  control which provides better than 10 ppm resolution.

### Highest frequency stability

While the basic frequency stability of the 606B is excellent (less than 0.005% drift over a 10 minute period after warm-up), the inclusion of frequency control circuitry in the 606B makes it possible to achieve 250 times greater stability by phase-locking the 606B with the HP 8708A Synchronizer. The 8708A, which is fully compatible with the 606B in every respect, can stabilize the 606B at any frequency (not just at discrete points) with a resultant stability of  $2 \times 10^{-7}/10$  minutes and a very high degree of spectral purity. The combination of the 606B and 8708A also permits you to perform narrow band frequency- or phase-modulation of the 606B carrier with very low modulation distortion. The 8708A is described on page 338.

### Simplified operation

An outstanding feature of the 606B is the employment of feedback in the RF power amplifier section which results in superior performance characteristics and true ease of operation. The feedback circuit maintains both the output level and the percentage of modulation essentially constant over the entire frequency range, thus making it unnecessary to readjust

controls when changing the operating frequency. The use of feedback also enables you to change the output level without affecting the degree of modulation. The constant output, constant modulation feature results in significant time saving as well as operator convenience, making the 606B an ideal choice for production line operations where semi-skilled personnel can make meaningful measurements.

### Versatile amplitude modulation

The use of feedback in the power amplifier section also yields excellent amplitude modulation characteristics. Up to 95% modulation can be achieved with modulating frequencies ranging from dc to 20 kHz. Envelope distortion is very low, less than 1% at 30% AM and less than 3% at 70% AM; this allows you to make more accurate measurements of the distortion characteristics on receivers or detectors. Internal modulation oscillators of 400 Hz and 1000 Hz are provided, and the modulation percentage can be set and read directly on the accurate front panel modulation meter. The wide modulation bandwidth (dc to 20 kHz) means the 606B may be modulated with squarewaves or other complex signals including tone-burst modulation, or you can remotely program the output amplitude. The buffer stage between the master oscillator and power amplifier holds incidental FM with AM to a minimum, assuring accurate measurements.

### Accurate output level

The output level from the 606B is continuously adjustable from 3 volts to 0.1 microvolts rms into a 50 ohm load. Direct calibration is provided in both volts and dBm (+23 to -120 dBm) and the output calibration is accurate to within 1 dB at any frequency or level setting. The output system of the 606B is a well matched 50 ohm circuit which minimizes mismatch ambiguities as a factor in overall measurement accuracy. The extremely wide range of output amplitude control makes the 606B very useful for driving bridges and filters as well as complete receiver measurements including sensitivity, selectivity, and image rejection.

The 606B provides an auxiliary RF output; this fixed level (100 millivolts rms minimum) CW signal is for use with the 8708A Synchronizer and can also be applied to an HP 5245L Counter for very accurate indication of carrier frequency. Using the auxiliary RF output does not place any restriction on the modulation capabilities nor on the main RF output level. The 606B also contains a crystal calibrator to provide accurate frequency checkpoints at every 100 kHz or 1 MHz throughout the frequency range of the instrument.

## Specifications, 606B

### Frequency characteristics

**Range:** 50 kHz to 65 MHz in 6 bands (50-170 kHz, 165-560 kHz, 0.53-1.8 MHz, 1.76-6 MHz, 5.8-19.2 MHz, 19-65 MHz); total scale length approximately 95 in.

**Accuracy:**  $\pm 1\%$ .

**Drift:** (attenuator on 1 volt range and below) less than 50 parts in  $10^8$  (or 5 Hertz, whichever is greater) per 10 minute period after 2 hour warmup; less than 10 minutes to restabilize after changing frequency.

**Stability when used with 8708A Synchronizer:**  $5 \times 10^{-8}$ /minute,  $2 \times 10^{-7}$ /10 minutes,  $2 \times 10^{-6}$ /day;  $2 \times 10^{-7}/^{\circ}\text{C}$ ,  $0^{\circ}$  to  $55^{\circ}\text{C}$ ;  $2 \times 10^{-7}$ /10% line voltage change.

**Resettability:** vernier control resettability better than 0.1% after initial warmup.

**$\Delta F$  control:** ultra-fine frequency vernier provides better than 10 parts in  $10^6$  settability; total range of  $\Delta F$  control approximately 0.1%.

**Crystal calibrator:** provides frequency checkpoints every 100 kHz and 1 MHz; headphone jack provided for audio frequency output (headphone not included); crystal frequency accuracy better than 0.01% from  $0^{\circ}$  to  $50^{\circ}\text{C}$ ; cursor on frequency dial adjustable over small range to aid in interpolation adjustment; calibrator may be turned off when not in use.

**Residual FM:** less than 1 part in  $10^9$  or 20 hertz peak, whichever is greater.

**Frequency control input:** BNC female connector for "frequency control output" from 8708A Synchronizer; can also be used for external frequency control; voltage change from  $-2$  to  $-32$  volts changes frequency approximately 0.2% at low end of each band and approximately 6% at high end; nominally 4 k ohm input impedance, direct-coupled; voltage limits: 0 volt  $\leq$  applied voltage  $\leq$  50 volts.

**Output level:** continuously adjustable from 0.1 microvolt to 3 volts into 50 ohm resistive load; output attenuator calibrated in 10 dB steps from 3 volt full scale to 1.0 microvolt full scale (into 50 ohms), also calibrated in dBm (0 dBm = 1 milliwatt in 50 ohms); vernier control provides continuous adjustment of voltage between full scale ranges; output level indicated on RF Output Meter calibrated in volts (0 to 1 and 0 to 3 volts) and dBm ( $-10$  to  $+3$  dBm).

**Frequency response and output accuracy** (attenuator range 1 volt and below; 50 ohm resistive load): at any output voltage setting, output level variation with frequency change is less than 2 dB, total, across entire frequency range; output accuracy better than  $\pm 1$  dB at any frequency.

**Impedance:** 50 ohms, SWR less than 1.1 on 0.3 volt attenuator range and below, less than 1.2 on 1 volt and 3 volt ranges.

**RFI:** meets all conditions specified in MIL-I-6181D; permits receiver sensitivity measurements down to at least 0.1 microvolt.

**Harmonic output:** at least 30 dB below the carrier.

**Spurious AM:** hum and noise sidebands are 70 dB below carrier down to thermal level of 50 ohm output system.

**Auxiliary RF output:** fixed level CW signal from RF oscillator (minimum amplitude 100 millivolts rms into 50 ohms) provided at front panel BNC female connector for use with HP 8708A Synchronizer or other external equipment (e.g., frequency control).

## Modulation characteristics

### Internal AM:

**Frequency:** 400 and 1000 Hz,  $\pm 5\%$ ; modulation signal available at front panel BNC female connector for synchronization of external equipment.

**Modulation level:** 0 to 95% on 1 volt range and below; 0 to at least 30% on 3 volt range.

**Carrier envelope distortion:** less than 1% at 30% AM; less than 3% at 70% AM (attenuator on 1 volt range and below).

### External AM:

**Frequency:** dc to 20 kHz maximum, dependent on carrier frequency ( $f_c$ ) and percent modulation as tabulated:

**Maximum modulation frequency:**

30% Mod:

$0.06f_c$ ;

70% Mod:

$0.02 f_c$ ;

Squarewave Mod:

$0.003 f_c$  (3 kHz max).

**Modulation level:** 0 to 95% on 1 volt attenuator range below, 0 to at least 30% on 3 volt range.

**Input required:** 4.5 volts peak produces 95% modulation (maximum input 50 volts peak); input impedance 1000 ohms.

**Carrier envelope distortion:** less than 1% at 30% AM, less than 3% at 70% AM (attenuator on 1 volt range and below).

**Modulation meter accuracy:**  $\pm 5\%$  of full scale, 0 to 90%, for modulation frequencies to 10 kHz,  $\pm 10\%$  of full scale for frequencies from 10 kHz to 20 kHz.

**Modulation level constancy (Internal or external AM; attenuator on 1 volt range and below):** modulation level stays constant within  $\pm 1/2$  dB regardless of carrier frequency and output level changes.

**Incidental frequency modulation (attenuator on 1 volt range and below, 30% modulation):** less than  $5 \times 10^{-6} \pm 100$  Hz peak.

### General

**Power:** 115 or 230 volts  $\pm 10\%$ , 50 to 400 Hz, 135 watts.

**Dimensions:** cabinet mount,  $20\frac{3}{4}$ " wide,  $12\frac{1}{2}$ " high,  $14\frac{3}{4}$ " deep, (527 x 318 x 370 mm).

**Weight:** cabinet mount, net, 53 lbs (23.9 kg); shipping, 64 lbs (28.8 kg); rack mount, net, 48 lb (21.6 kg); shipping, 62 lb (27.9 kg).

### Accessories available:

11507A Output Termination, provides 3 positions: 50 ohms (for use into high impedance); 5 ohms (10:1 voltage division); IEEE Standard Dummy Antenna (driven from 10:1 divider); price, \$70.

11509A Fuse Holder, provides protection for output attenuator when 606B is used for transceiver tests; price, \$25.

10514A Mixer, for use as nanosecond pulse modulator; price, \$250.

**Price:** Model 606B (cabinet mount), \$1550. ; Model 606BR (rack mount), \$1535.

### Model 606A

The Model 606A covers the same frequency ranges as the 606B, but does not include the frequency control input feature that allows frequency stabilization by the Model 8708A Synchronizer. Model 606B specifications apply to the 606A with the following exceptions: an auxiliary uncalibrated RF output is not included; harmonic output is less than 3%; the crystal calibrator provides check points at 100 kHz (useful to 6 MHz) and 1 MHz intervals; output power level frequency response is  $\pm 1$  dB over the entire frequency range.

**Price:** HP 606A (cabinet), \$1,350; HP 606AR (rack mount) \$1,335.



## VHF SIGNAL GENERATORS

Improved versatility and value 10-480 MHz  
Models 608C/D/E/F; 8708A

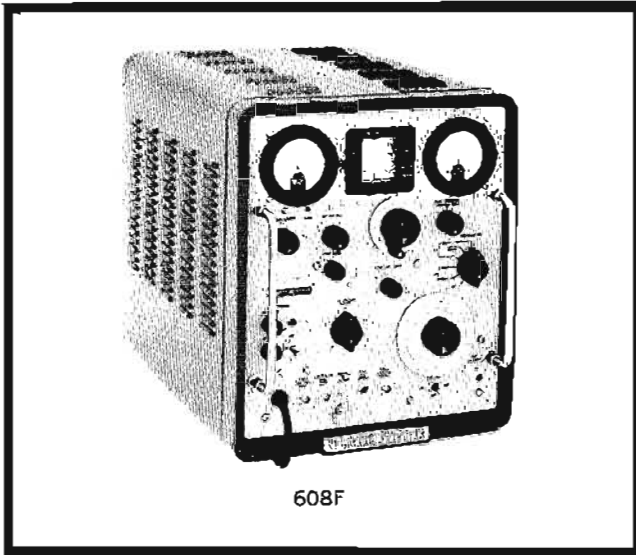

### Description

Models 608E and 608F provide high-quality, versatile performance with distinctive ease of operation. The 608E provides an output of up to 1 volt over the range from 10 to 480 MHz, and the 608F provides an output of up to 0.5 volt from 10 to 455 MHz.

The 608E is an improved version of the popular and time-proven HP 608C/D Signal Generators. The instrument is a master oscillator-power amplifier (MOPA) type with a broadband buffer amplifier stage between the oscillator and power amplifier circuits for isolation. The MOPA design permits optimization of the oscillator stage for high stability of 0.005% per 10 minutes, minimum residual FM, and low harmonics without restricting the modulation characteristics. Modulation is applied to the power amplifier stage with negligible effect on the oscillator frequency.

### Modulation capability

The use of feedback in the power amplifier section yields excellent amplitude modulation characteristics. Up to 95% modulation can be achieved with modulating frequencies ranging from 20 Hz to 20 kHz. Envelope distortion is very low, less than 2% at 30% AM and less than 5% at 70% AM; this allows you to make more accurate measurements of the distortion characteristics on receivers or detectors. Internal modulation oscillators of 400 Hz and 1000 Hz are provided, and the modulation percentage can be set and read directly on the accurate front panel modulation meter. The buffer amplifier stage between the master oscillator and power amplifier holds incidental FM with AM to a minimum, assuring accurate measurements.

### Accurate output level

Output levels of the Models 608E/F are accurately attenuated to provide continuously adjustable calibrated output to 0.1 microvolt rms into a 50 ohm load. Direct calibration is provided in both volts and dBm (to -127 dBm) and the output calibration is accurate to within 1 dB at any frequency or level setting. The output system of the 608E/F is a well matched 50 ohm circuit which minimizes mismatch ambiguities as a factor in overall measurement accuracy. The extremely

wide range of output amplitude control makes the 608F very useful for driving bridges and filters as well as complete receiver measurements including sensitivity, selectivity, and image rejection.

Models 608E/F provide an auxiliary RF output; this fixed level (180 millivolts rms minimum) CW signal is for use with an HP 5245L Counter for very accurate indication of carrier frequency. On the 608E, this output is also for use with the 8708A Synchronizer. Using the auxiliary RF output does not place any restriction on the modulation capabilities nor on the main RF output level. The units also contain a crystal calibrator to provide accuracy frequency checkpoints at every 1 or 5 MHz throughout the frequency range.

### High settability

The fine frequency vernier is an electronic fine tuning adjustment of the output frequency. Frequency settability with better than 10 ppm resolution is possible to obtain precise settings for critical tests. When used with the internal crystal calibrator, 608E frequency accuracy can be increased by a factor of 50 (factor of 100 for the 608F) over the main dial calibration of 1% without the use of an external frequency meter.

### 608F/8708A combination

The Model 8708A Synchronizer is an easy-to-use frequency stabilizer that allows the 608F to be phase-locked at any frequency. Full AM and output level features of the 608F are retained during phase-lock. The 8708A increases frequency stability by a factor of 250 with the extra benefit of 8708A precise tuning resolution for settability to 2 parts in  $10^7$ . The 608F/8708A combination also permits narrowband frequency and phase modulation to be applied with very low distortion. See page 338.

### Specifications, 608E/F

#### Frequency characteristics

**Range:** 608E: 10 - 480 MHz in 5 bands (10-21, 21-43, 43-95, 95-215, and 215-480 MHz). 608F: 10 - 455 MHz in 5 bands (10-21, 21-44, 44-95, 95-210, and 210-455 MHz).

**Accuracy:** 608E:  $\pm 0.5\%$ . 608F:  $\pm 1\%$ .

**Drift:** 608E: less than 50 parts in  $10^6$  per 10 minute period after one hour warmup. Less than 10 minutes to restabilize after changing frequency. 608F: less than 50 parts in  $10^6$  per 10 minute period after one hour warmup; less than 10 minutes to restabilize after changing frequency; stability when used with 8708A Synchronizer:  $5 \times 10^{-8}$ /minute;  $2 \times 10^{-7}$ /10 minutes;  $2 \times 10^{-4}$ /day;  $2 \times 10^{-7}$ /°C (0° to 55°C);  $2 \times 10^{-7}$ /10% line voltage change.

**Frequency control input (608F ONLY):** BNC female connector for "Frequency Control Output" from 8708A Synchronizer can also be used for external frequency control; voltage change from -2 to -32 volts changes frequency approximately 0.2% at low end of each band and approximately 2% at high end; nominal k $\Omega$  input impedance, direct-coupled; voltage limits, 0 to -50 V.

**Resettability:** 608E: main frequency control resettability better than  $\pm 0.1\%$  after initial warmup; Fine Frequency Adjust provides approximately 25 kHz settability at 480

MHz (proportionately finer adjustment at lower frequencies). 608F: main frequency control resettability better than  $\pm 0.1\%$  after initial warmup; Fine Frequency Adjust provides approximately 25 kHz settability at 455 MHz (proportionately finer adjustment at lower frequencies).

**Tuning control:** frequency control mechanism provides a main dial calibrated in megacycles and a vernier dial for interpolation purposes; total scale length, approximately 45 inches; calibration, every other megahertz 130 to 270 MHz; every 5 MHz above 270 MHz.

**Crystal calibrator:** provides frequency check points every 1 MHz or 5 MHz over the range of the instrument; headphone jack provided for audio frequency output (headphones not included); crystal frequency accuracy better than 0.01% at normal room temperatures; cursor on frequency dial adjustable over small range to aid in interpolation adjustment; calibrator may be turned off when not in use.

**Residual FM:** less than 5 parts in  $10^7$  peak.

**Harmonic output:** at least 35 dB below the carrier.

#### Output characteristics

**Output level:** 608E: continuously adjustable from 0.1  $\mu$ volt to 1.0 volt into a 50 ohm resistive load; output attenuator calibrated in volts and dBm (0 dBm = 1 mW in 50 ohms).

608F: continuously adjustable from 0.1  $\mu$ volt to 0.5 volt into a 50 ohm resistive load; output attenuator calibrated in volts and dBm (0 dBm = 1 mW in 50 ohms).

**Accuracy:** within  $\pm 1$  dB of attenuator dial reading at any frequency when RF Output Meter indicates "ATTENUATOR CALIBRATED."

**Leveling:** internal feedback circuit retains "ATTENUATOR CALIBRATED" reference on RF Output Meter over wide frequency ranges (typically octave bands); adjustment of front panel AMP. TRIMMER control (only) for maximum RF output indication automatically restores initial carrier level for greater frequency changes.

**Impedance:** 50 ohms with a maximum SWR of 1.2 for attenuator setting below  $-7$  dBm.

**RFI:** meets all conditions specified in MIL-I-6181D; permits receiver sensitivity measurements down to at least 0.1 microvolt.

**Auxiliary RF output:** 608E: fixed level CW signal from RF Oscillator (minimum amplitude 180 mV rms into 50 ohms) provided at front panel BNC female connector for use with external equipment (e.g., frequency counter).

608F: fixed level CW signal from RF Oscillator (minimum amplitude 180 mV rms into 50 ohms) provided at front panel BNC female connector for use with HP 8708A Synchronizer or other external equipment (e.g., frequency counter).

#### Modulation characteristics

(Front panel AMP TRIMMER control adjusted for maximum indication on RF Output Meter and RF Output Meter set to "ATTENUATOR CALIBRATED.")

#### Internal AM

**Frequency:** 400 and 1000 Hz,  $\pm 10\%$ ; modulation signal available at front panel BNC female connector for synchronization of external equipment.

**Modulation level:** 608E: 0 to 95%, modulation at carrier

levels 0.5 volt and below; continuously adjustable with front panel MOD LEVEL control.

608F: 0 to 95% modulation with Output Attenuator at 0.224 volt (1 mW) or below; continuously adjustable with front panel MOD LEVEL control.

**Carrier envelope distortion:** less than 2% at 30% AM and less than 5% at 70% AM.

#### External AM

**Frequency:** 20 Hz to 20 kHz.

**Modulation level:** 608E: 0 to 95% modulation at carrier levels of 0.5 volt and below; continuously adjustable with front panel MOD LEVEL control; input required, 1-10 volts, rms (1000 ohms input impedance).

608F: 0 to 95% modulation with Output Attenuator at 0.224 volt (1 mW) or below; continuously adjustable with front panel MOD LEVEL control; input required, 1-10 volts, rms (1000 ohms input impedance).

**Carrier envelope distortion:** less than 2% at 30% AM, less than 5% at 70% AM.

External control of carrier level can be achieved through application of dc voltage in EXT AM mode.

**Modulation meter accuracy:**  $\pm 5\%$  of full scale 0 to 80%,  $\pm 10\%$  from 80% to 95% (for INT AM or 20 Hz to 20 kHz EXT AM).

**Incidental frequency modulation (at 400 and 1000 Hz modulation):** less than 1000 Hz peak at 50% AM for frequencies above 100 MHz; for frequencies below 100 MHz, less than 0.001% at 30% AM.

#### External pulse modulation:

**Rise and decay time:** from 40 MHz to 220 MHz, combined rise and decay time less than 4  $\mu$ sec; above 220 MHz combined rise and decay time less than 2  $\mu$ sec.

**On-off ratio:** at least 20 dB for pulsed carrier levels of 0.5 volt and above.

**Input required:** positive pulse, 10-50 volts peak, input impedance 2000 ohms.

#### General:

**Power:** 115 or 230 volts  $\pm 10\%$ , 50 to 400 Hz; approximately 220 watts.

**Dimensions:** cabinet: 13 $\frac{1}{4}$ " wide, 16 $\frac{3}{8}$ " high, 21" deep (337 x 416 x 533 mm); rack mount: 19" wide, 13-31/32" high, 18 $\frac{3}{8}$ " deep behind panel (483 x 335 x 467 mm).

#### Weight:

**Cabinet mount:** net, 62 lbs (28 kg); shipping, 73 lbs (33 kg).

**Rack mount:** net, 62 lbs (28 kg); shipping, 89 lbs (40 kg).

#### Accessories available:

11508A output cable provides 50 ohms termination and standard binding posts at the end of a 24-inch (610 mm) length of cable; allows direct connection of the signal generator to high impedance circuits. \$18.00.

11509A Fuse Holder provides protection for the output attenuator when the Model 608E/F is used for transmitter tests. \$25.00.

10514A Mixer for use as nanosecond pulse modulator or balanced modulator. \$250.00.

**Price:** Model 608E (cabinet), \$1450.00; Model 608ER (rack mount), \$1470.00; Model 608F (cabinet), \$1600.00; Model 608FR (rack mount), \$1620.00.



## VHF SIGNAL GENERATORS CONTINUED

Improved versatility and value 10-480 MHz

Models 608C/D/E/F; 8708A



HP Model 8708A Synchronizer

The 8708A Synchronizer is a phase-lock frequency stabilizer that allows you to obtain crystal-oscillator frequency stability in the 606B and 608F Signal Generators at any frequency within their ranges. The outstanding AM and output level control capabilities of the signal generators are retained. Phase-locking eliminates microphonics and drift, resulting in a frequency stability of  $2 \times 10^{-7}$  per 10 minutes, an increase by a factor of 250. The 8708A includes an ultrafine frequency vernier which can tune the reference oscillator over a range of  $\pm 0.25\%$  permitting frequency settability to 2 parts in  $10^7$ . This high order stability and settability can be achieved at any frequency in the 606B and 608F range, eliminating phase-locking at only discrete frequencies. This provides a very stable, yet tunable signal generator that satisfies many critical applications including measurements on SSB and narrowband receivers.

An external 20 MHz frequency reference can be used; the resultant stability is that of the external reference. Use of an external reference, however, results in just fixed discrete lock points (unless the reference is frequency tunable  $\pm 0.25\%$  around 20 MHz).

Narrowband frequency and phase modulation with very low distortion (better than 1% linearity) of the 606B and 608F Signal Generators can be applied through the 8708A. Narrowband sweeping of the carrier under very stable conditions is valuable for filter or amplifier skirt response tests as well as Q studies of frequency selective circuits.

### Specifications, 8708A

**Frequency range:** 50 kHz to 500 MHz; phase-locks 606B or 608F Signal Generator at any carrier frequency\*, with  $2 \times 10^{-7}$  settability.

**Input signal level (signal to be stabilized):** proper signal level automatically provided by 606B and 608F; general requirements:

50 kHz to 20 MHz: 0.25 to 5 V p-p into 50 ohms; 10 to 500 MHz, 300 mV rms  $\pm 3$  dB (<20% distortion), into 50 ohms.

**Frequency reference:** internal or external 20 MHz ( $\pm 0.25\%$ ); external reference requirements: (a) when signal to be synchronized is between 50 kHz and 20 MHz, 230 mV rms  $\pm 1$  dB (less than 20% distortion), into 50 ohms; (b) when signal to be synchronized is between 10 MHz and 500 MHz, 0.25 to 5 V p-p into 50 ohms.

**Internal frequency reference stability:**

**Short term (RMS deviation):**  $5 \times 10^{-8}$ /minute;  $2 \times 10^{-7}$ /10 minutes.

**Long term:**  $2 \times 10^{-6}$ /day.

**With temperature:**  $2 \times 10^{-7}$ /°C, 0 to 55°C.

**With line voltage:**  $2 \times 10^{-7}$ /10% line voltage change.

(Note: stability in "External Reference" mode is that of external reference source).

**Spectral purity (stabilized RF output of 606B or 608F Signal Generator):**

**Spurious signals:** non-harmonically related signals greater than 60 dB below carrier.

**Signal-to-AM noise ratio\*\*:** greater than 70 dB.

**Signal-to-phase noise ratio\*\*:** greater than 60 dB.

**RMS fractional frequency deviation:** less than  $5 \times 10^{-8}$  averaged over 10 msec (30 kHz noise bandwidth).

**Frequency control output:** frequency control voltage directly compatible with 606B and 608F Signal Generators; output voltage range, -2 to -32 volts (max).

### Modulation

**Frequency modulation:** maximum modulation rates and frequency deviation for  $\leq 1\%$  distortion:

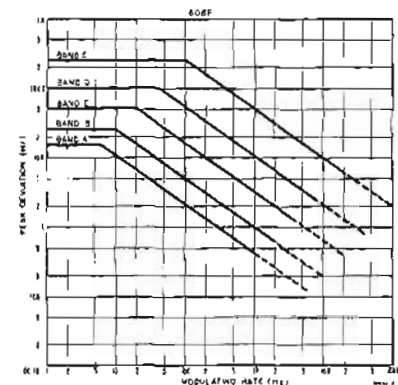
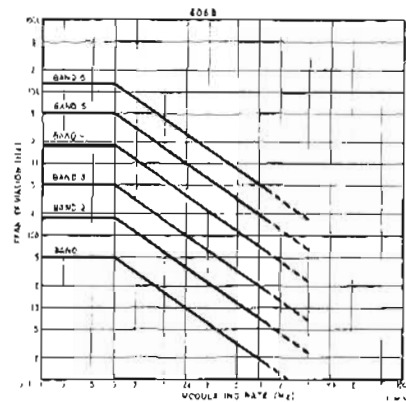

**Modulation sensitivity (ac or dc):**

Mod. level control at maximum

$$\frac{10 \text{ kHz}}{\text{volt}} \times \frac{\text{carrier freq. (MHz)}}{20}$$

**Note:** dc input limits, 0 to 10 volts (input connector biased at +10 V from a 10 k ohm source).

**Phase modulation:** maximum modulation rate and phase deviation for  $\leq 1\%$  distortion:

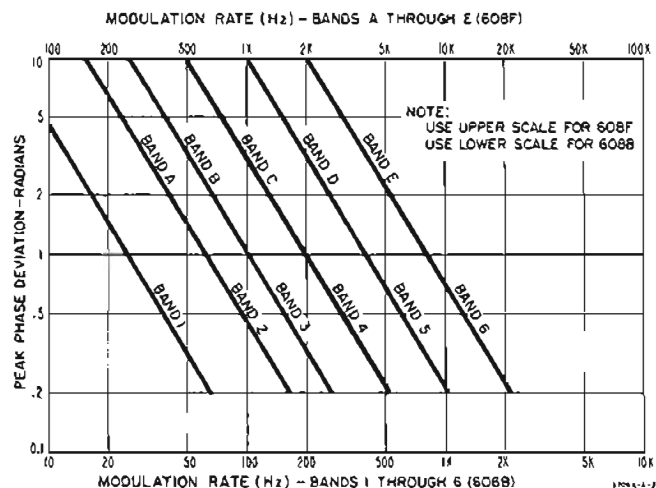

**Modulation sensitivity (ac only):** Mod. level control at maximum

$$\frac{10^4}{\text{mod. freq. (Hz)}} \left( \frac{\text{radians}}{\text{volt}} \right) \times \frac{\text{carrier freq. (MHz)}}{20}$$

**Deviation monitor:** dc output voltage which is proportional to frequency and phase deviation; output voltage, deviation ratio varies with carrier frequency, output voltage range approximately -1 to +3 V.

**RFI:** meets all conditions specified in MIL-I-6181D.

**Power:** 115 or 230 volts  $\pm 10\%$ , 50 to 400 Hz; approximately 48 watts.

**Dimensions:** 16 $\frac{3}{4}$ " wide, 3-25/32" high, 18 $\frac{3}{8}$ " deep (425 x 96 x 467 mm); hardware furnished for rack mount, 19" wide, 3-15/32" high, 16 $\frac{3}{8}$ " deep behind panel (483 x 88 x 416 mm).

**Furnished:** interconnecting cables for use with 606B and 608F Signal Generators.

**Weight:** net, 24 lb (10.8 kg); shipping, 29 lb (13.1 kg).

**Price:** Model 8708A, \$1800.00.

### Models 608C and 608D VHF Signal Generators

The Model 608C/D are designed as broadly applicable VHF signal generators. Both units feature internal modulation of 400 and 1000 Hz standard test tones for routine AM applications, and can be externally modulated up to 95%. Versatile

\*Using 8708A Internal Reference, or external reference adjustable over 0.5% frequency range. With fixed frequency external reference, interval between lock points varies from 62.5 Hz at 50 kHz to 500 kHz above 210 MHz.

\*\* In a 30 kHz band centered on the carrier, excluding a 1 Hz band centered on the carrier.

modulation capabilities allow pulse and transient testing of VHF receivers. Accuracy of measurements is enhanced by 608C/D minimum incidental FM with AM, modulation distortion, and frequency drift. Models 608C/D feature calibrated RF output attenuation down to 0.1  $\mu\text{V}$ , and provide high quality pulses as short as 1  $\mu\text{sec}$  at RF frequencies above 100 MHz.

The Model 608C is a high power, stable and very accurate generator for general lab and field use, providing 1 volt maximum RF output and broad frequency coverage from 10 to 480 MHz.

Maximum output of the 608D is 0.5 volt through the range of 10 to 420 MHz. A built-in crystal calibrator provides accurate frequency check points at 1 and 5 MHz intervals.

### Major specifications, 608C,D

**Frequency range:** 608C, 10 to 480 MHz in 5 bands; 608D, 10 to 420 MHz in 5 bands.

**Frequency dial calibration accuracy:** 608C,  $\pm 1\%$ ; 608D,  $\pm 0.5\%$ .

**Resettability:** better than  $\pm 0.1\%$  after warm-up.

**Frequency drift:**  $< 0.005\%$  over a 10 minute interval after initial warm-up (15 to 35°C ambient).

**Output level:** 608C, 0.1  $\mu\text{V}$  to 1 V into 50 $\Omega$ ; 608D, 0.1  $\mu\text{V}$  to 0.5 V into 50 $\Omega$ ; attenuator dial calibrated in volts and dBm; (0 dBm equals 1 mW).

**Output voltage accuracy:**  $\pm 1$  dB into 50 $\Omega$ .

**Generator impedance:** 50 ohms; maximum SWR 1.2.

**Internal AM:** 400 Hz  $\pm 10\%$  and 1000 Hz  $\pm 10\%$ .

**External AM:** 0 to 95% at output levels of 0 dBm and below at modulation frequencies 20 Hz to 20 kHz; input requirements, 0.5 V rms across 15 k $\Omega$ .

**Modulation meter accuracy:**  $\pm 10\%$  of full scale, 30% to 95% modulation.

**Envelope distortion:** less than 5% at 30% sine-wave modulation; less than 10% at 50% sine-wave modulation.

**External pulse modulation:** positive 5 V peak pulse required; 40 to 220 MHz, combined rise and decay time of RF pulse less than 4  $\mu\text{sec}$ ; above 220 MHz, combined rise and decay time of RF pulse less than 1  $\mu\text{sec}$ ; pulse on-off ratio at least 20 dB.

**Incidental FM:** 608C,  $< 0.0025\%$  at 30% AM, 21 to 480 MHz; 608D,  $< 1000$  Hz peak at 50% AM above 100 MHz,  $< 0.001\%$  at 30% AM below 100 MHz.

**Price:** HP 608C, \$1250 (cabinet); HP 608CR, \$1270 (rack mount); HP 608D, \$1350 (cabinet); HP 608DR \$1370 (rack mount).

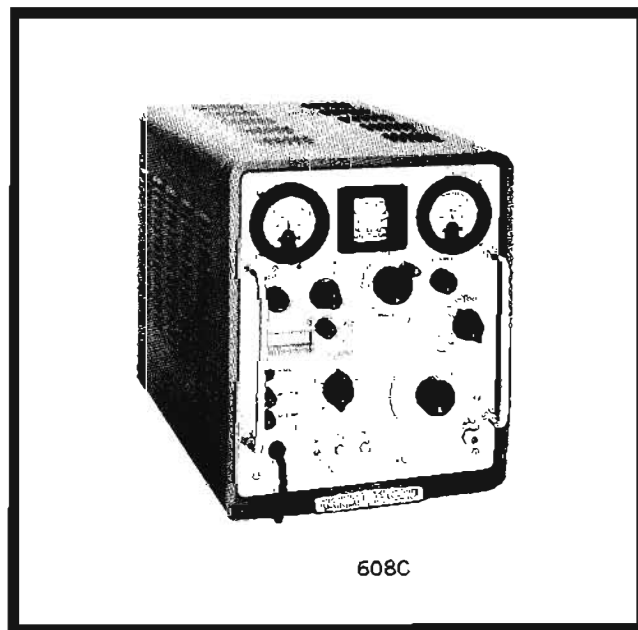

608C





## VHF OSCILLATOR

10 to 500 MHz; to 1000 MHz with Accessory Probe  
Model 3200B

The HP 3200B VHF Oscillator provides low cost, stable, 10 to 500 MHz RF for testing receivers and amplifiers, and driving bridges, slotted lines, antennas, and filter networks. Good pulse modulation sensitivity allows standard audio oscillators to be used to provide usable square-wave modulation; a 2.5-volt sine wave will provide adequate drive for this type application. The 3200B can also serve as a local oscillator for heterodyne detector systems and as a marker source for swept systems. An optional accessory Frequency Doubler Probe, HP 13515A, provides additional frequency coverage from 500 to 1000 MHz.

Though the oscillator stability is specified as .005% for a 5-minute period after warmup, typical data indicates that,

under controlled conditions, stabilities of 0.0001% are attainable at some frequencies.

Effective RF shielding permits measurements at levels down to 1  $\mu$ V.

A front panel vernier control varies the plate voltage in the oscillator, electrically refining the attenuator piston setting.

RF is read on an expanded slide-rule type scale. The oscillator may be precisely tuned by means of a mechanical vernier activated by the main tuning control.

The 3200B is well suited for bench use and may be adapted for standard 19-inch rack mounting.

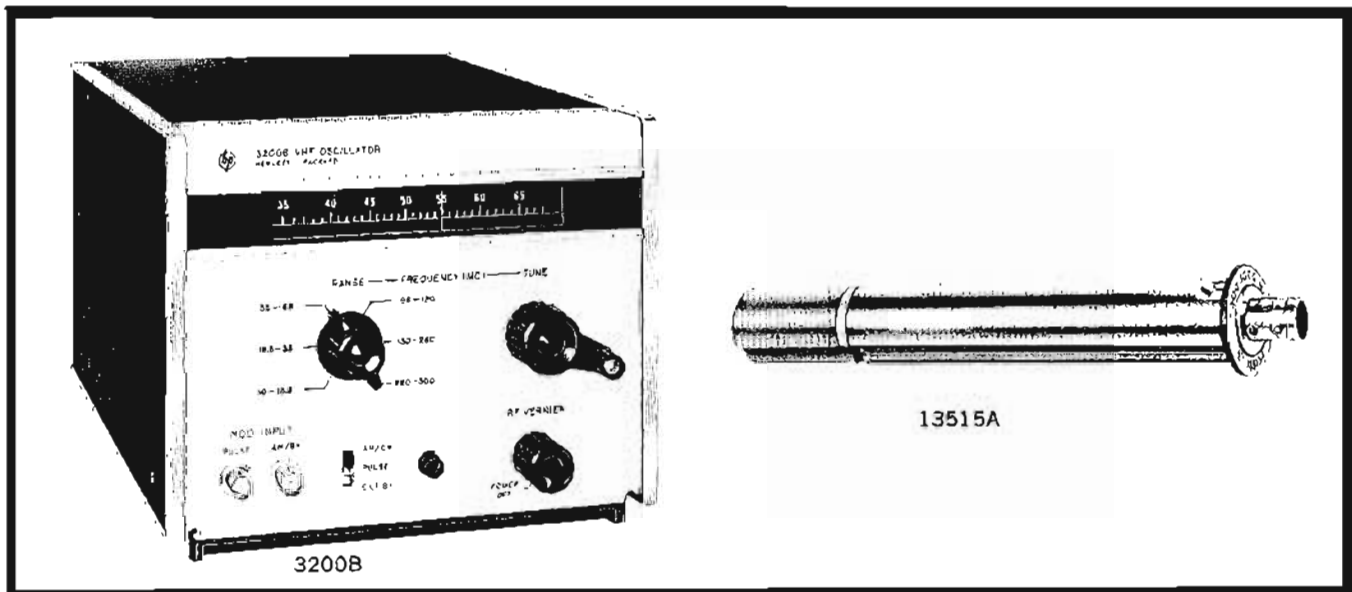

### Specifications

**Frequency range:** 10 to 500 MHz in six bands: 10 to 18.8 MHz; 18.5 to 35 MHz; 35 to 68 MHz; 68 to 130 MHz; 130 to 260 MHz; 260 to 500 MHz.

**Frequency accuracy:** within  $\pm 2\%$  after 1/2 hour warmup.

**Frequency calibration:** increments of less than 4%.

**Frequency stability (after 4-hour warmup under 0.2 mW load):** short term (5 minutes)  $\pm 0.002\%$ ; long term (1 hour)  $\pm 0.02\%$ ; line voltage (5-volt change)  $\pm 0.001\%$ .

#### RF output:

**Maximum power (across 50-ohm external load):** >200 mW (10 to 130 MHz); >150 mW (130 to 260 MHz); >25 mW (260 to 500 MHz).

**Range:** 0 to >120 dB attenuation from maximum output.

**Load impedance:** 50 ohms nominal.

**RF leakage:** sufficiently low to permit measurements at 1  $\mu$ V.  
RFI: meets requirements of MIL-I-6181D.

**Amplitude modulation:** externally modulated.

**Range:** 0 to 30%.

**Distortion:** <1% at 30% AM.

**External requirements:** approximately 20 volts rms into 600 ohms for 30% AM, 200 Hz to 100 kHz.

**Pulse modulation:** externally modulated.

**External requirements:** 2.5-volt negative pulse into 2000 ohms.

**Power:** 105 to 125 V or 210 to 250 V, 50 to 1000 Hz, 30 W.

**Dimensions:** 7 $\frac{3}{8}$ " wide, 6 $\frac{1}{2}$ " high, 13 $\frac{1}{8}$ " deep (194 x 165 x 333 mm).

**Weight:** net 15 lbs (6,8 kg), shipping 19 lbs (8,6 kg).

**Accessories available:** 13515A Frequency Doubler Probe; 00501B, 00514B, 00517B Output Cables; 00502B, 00506B Patching Cables.

**Price:** HP 3200B, \$475; HP 13515A, \$95.

## UHF SIGNAL GENERATOR

All-purpose uhf signal generator, 450 to 1230 MHz  
Model 612A



## SIGNAL SOURCES

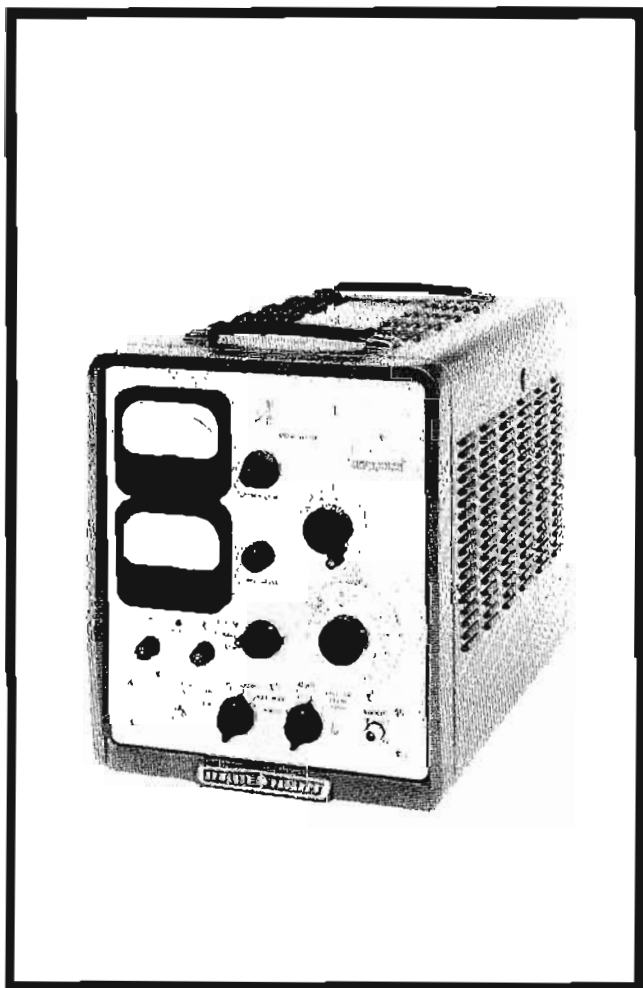

Here is an all-purpose, precision signal generator particularly designed for utmost convenience and applicability throughout the important uhf-tv frequency band. It is ideally suited for measurements in uhf-television broadcasting, studio-transmitter links, citizen's radio and public service communications systems. The HP 612A also covers the important frequencies used in aircraft navigation aids such as DME, TACAN and airborne transponders. Accessory modulators, available from many of the manufacturers of these navigational aids, enable the 612A to provide the complex modulation patterns required for testing and aligning these systems. In the laboratory, the 612A is a convenient power source for driving bridges, slotted lines, antennas and filter networks. In addition, the HP 8731 PIN Modulators can be used with the 612A to obtain rf pulses with 30 nsec rise time and 0.1  $\mu$ sec minimum duration — with on-off ratios approaching 80 dB.

### MO-PA circuit

The master oscillator-power amplifier circuit in HP 612A provides 0.5 volt into 50 ohms over the full frequency range of 450 to 1230 MHz. There is very low incidental FM (less than 0.002% at 30% AM) and excellent modulation capabilities by all frequencies from 20 Hz to 5 MHz. The degree of modulation is easily read from the large Percent Modulation meter. The instrument can be amplitude modulated (either

internally or externally), and provision is made for external pulse modulation, as well. Pulse modulation can be applied to the amplifier, or directly to the oscillator when high on-off signal ratios are required (signal may be completely cut off between pulses). Modulation can be up or down from preset level to simulate tv modulation characteristics accurately.

### Advanced design

The oscillator-amplifier circuit in the 612A employs high-frequency pencil triodes in a cavity-tuned circuit for precise tracking over the entire band. Non-contacting cavity plungers are die cast to precise tolerances, then injection molded with a plastic filler for optimum Q. The frequency drive is a direct screw-operated mechanism, free from backlash. A waveguide-beyond-cutoff piston attenuator and crystal monitor circuit are used to insure accurate, reliable output down to 0.1  $\mu$ volt. The attenuator is calibrated over a range of 131 dB and has been carefully designed to provide a constant impedance-versus-frequency characteristic. The swr of the 50-ohm output system is less than 1.2 over the complete frequency range.

### Specifications

**Frequency range:** 450 to 1230 MHz in one band; scale length approximately 15" (381 mm).

**Calibration accuracy:** within  $\pm 1\%$ ; resetability better than 5 MHz at high frequencies.

**Output voltage:** 0.1  $\mu$ V to 0.5 V into 50-ohm load; calibrated in V and dBm (0 dBm = 1 mW).

**Output accuracy:**  $\pm 1$  dB, 0 to  $-127$  dBm over entire frequency range.

**Internal impedance:** 50 ohms; maximum reflection coefficient, 0.091 (1.2 swr, 20.8 dB return loss).

**Amplitude modulation:** above 470 MHz, 0 to 90% at audio frequencies, indicated by panel meter; accuracy  $\pm 10\%$  of full scale, 30 to 90% modulation.

**Incidental FM:** less than 0.002% for 30% AM.

**Internal modulation:** 400 and 1000 Hz  $\pm 10\%$ ; envelope distortion less than 2% at 30% modulation.

**External modulation:** 20 Hz to 5 MHz; above 470 MHz, 2 V rms produces 85% AM at modulating frequencies up to 500 kHz, at least 40% AM at 5 MHz; modulation may be up or down from the carrier level or symmetrical about the carrier level; positive or negative pulses may be applied to increase or decrease rf output from the carrier level.

### Pulse modulation

**Pulse 1** (pulse applied to amplifier): positive or negative pulses, 4 to 40 V peak produce an rf on-off ratio of at least 20 dB; minimum rf output pulse length, 0.2  $\mu$ sec.

**Pulse 2** (pulse applied to oscillator): positive or negative pulses, 4 to 40 V peak; no rf output during off time; minimum rf output pulse length, 1  $\mu$ sec.

**RFI:** conducted and radiated leakage limits are below those specified in MIL-I-6181D; permits receiver sensitivity measurements down to 1  $\mu$ V.

**Power:** 115 or 230 volts  $\pm 10\%$ , 50 to 400 Hz, 215 watts.

**Dimensions:** cabinet: 13 $\frac{1}{2}$ " wide, 16 $\frac{1}{2}$ " high, 21 $\frac{1}{2}$ " deep (343 x 419 x 546 mm); rack mount: 19" wide, 13-31/32" high, 20 $\frac{1}{4}$ " deep behind panel (483 x 355 x 514 mm).

**Weight:** net 56 lbs (25.4 kg), shipping 68 lbs (30.5 kg) (cabinet); net 56 lbs (25.4 kg), shipping 72 lbs (32.4 kg) (rack mount).

**Accessories available:** 11500A RF Cable Assembly, \$15; 10503A Video Cable Assembly, \$6.50; 360B Low-Pass Filter (may be used where harmonic output must be reduced to a minimum, as in slotted line measurements), \$70.

**Price:** HP 612A, \$1400 (cabinet); HP 612AR, \$1420 (rack mount).



## SIGNAL GENERATORS; SOURCES

Stable, easy to use, cover 800 to 4500 MHz

Models 8614A, 8616A; 8614B, 8616B

### Advantages:

- High frequency accuracy, digital dial
- Precision attenuator, digital dial
- Amplitude modulation capability and automatic power leveling in the signal generators
- Compact, only 5¼" (133 mm) high

### Use to measure:

- Receiver sensitivity
- Standing wave ratios
- Transmission line characteristics
- Conversion gain

The HP 8614A and 8616A Signal Generators are easy-to-use instruments which provide stable, accurate signals from 800 to 2400 MHz (8614A) and from 1800 to 4500 MHz (8616A). Both frequency and attenuation are set on direct-reading digital dials, while function is easily selected by pushbuttons. Selectable functions include cw, leveled output, square-wave modulation, and external amplitude, pulse or frequency modulation. Amplitude, frequency and square-wave modulation can be accomplished simultaneously with or without leveling.

### Two outputs

Two rf power outputs are simultaneously available from separate front-panel connectors. One provides at least 10

mW (2 mW above 3000 MHz, or a leveled output from 0 to -127 dBm. The leveled output is flat within  $\pm 0.5$  dB (8614A) or  $\pm 0.8$  dB (8616A) across the respective bands with no resetting of the attenuator or power monitor.

The second output is at least 0.5 mW across the band and is independent of attenuator setting. This signal can be used for phase locking the signal generators when extreme stability is desired, or it can be monitored with a frequency counter for extreme frequency resolution. In any case, the second output can be utilized without adversely affecting the primary output.

### Modulation capabilities

A unique PIN diode modulator permits amplitude modulation from dc to 1 MHz or furnishes rf pulses with a 2 $\mu$ sec rise time. This broad modulation bandwidth permits remote control of output level or precise leveling using external equipment. The internal leveling is also obtained by using a PIN modulator.

When up to one watt output is required above 1 GHz, the HP 489A (1 to 2 GHz) or HP 491C (2 to 4 GHz) Microwave Amplifiers (see Amplifiers) serve as ideal power boosters. The HP 8731 and 8732 Series PIN Modulators, driven by the HP 8403A Modulator (see Mixers, Modulators, Attenuators), also are available for use with the signal generators when a sophisticated high-speed, low-jitter modulation system is required.



8614A

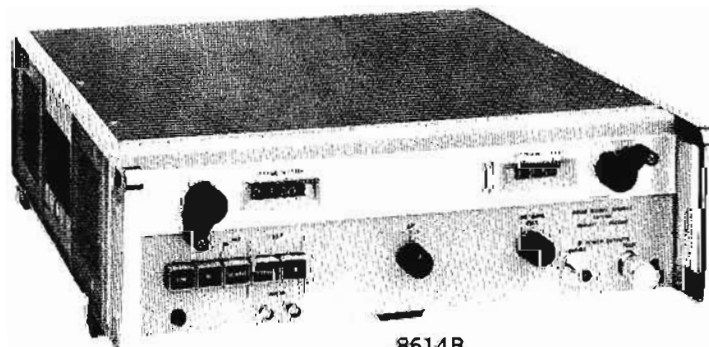

8614B

## Signal Sources

The HP 8614B and 8616B retain the convenience of the "A" models. Functions are selected by pushbuttons, and frequency and attenuation are set on digital dials. Although the signal sources do not have power monitors or internal PIN diode modulation, relative power measurements can be made, using the precision attenuator. Modulation capabilities include internal square-wave modulation, plus external pulse and frequency modulation. For added convenience, a friction clutch arrangement permits setting the attenuator dial to any suitable reference while output power is held constant. Thus the attenuator can be calibrated directly in dBm or insertion loss.

The versatility of the HP 8614B and 8616B makes them suitable for both laboratory and general-purpose measurements. Indeed, these signal sources can be used in many applications previously requiring signal generators.

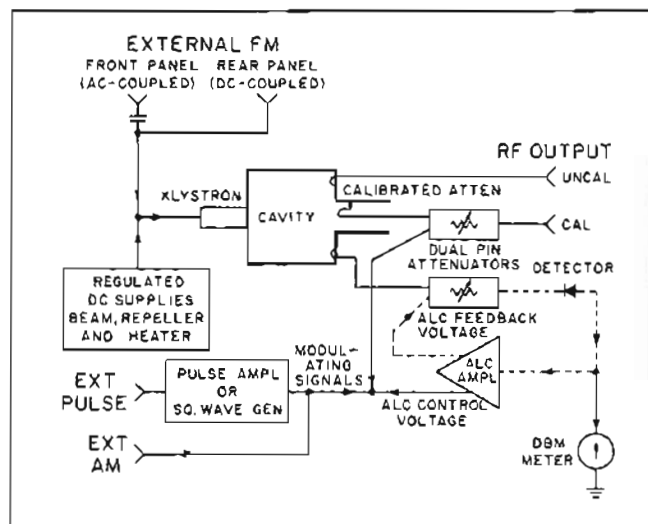

Simplified block diagram of hp 8614A and 8616A Signal Generators. The dashed line shows the leveling control circuit.

### Specifications

**Frequency range:** 8614A and 8614B, 800 to 2400 MHz; 8616A and 8616B, 1800 to 4500 MHz.

**Leveled output:** constant within  $\pm 0.5$  dB (8614A) and  $\pm 0.8$  dB (8616A) across entire frequency range at any attenuator setting below 0 dB; output power can be adjusted from the normal calibrated level with the Automatic Level Control; not available with 8614B and 8616B.

**Frequency calibration accuracy:** 8614A,  $\pm 5$  MHz; 8614B,  $\pm 5$  MHz or  $\pm 0.5\%$ , whichever is greater; 8616A,  $\pm 10$  MHz; 8616B,  $\pm 10$  MHz or  $\pm 0.5\%$ , whichever is greater. Vernier:  $\Delta F$  control has a minimum range of 1.5 MHz for fine tuning.

#### Frequency stability

**With temperature:** approximately 0.005%/°C change in ambient temperature.

**With line voltage:** less than 0.003% change for line voltage variation of  $\pm 10\%$ .

**Residual FM:** 8614A and 8616A, less than 2500 Hz peak; 8614B, less than 0.0003% peak; 8616B, less than 6 kHz peak.

#### RF output power

8614A: +10 dBm (10 mW) to -127 dBm (0.1  $\mu$ V) into a 50-ohm load; output attenuator dial directly calibrated in dBm from 0 to -127 dBm.

8614B: at least 15 mW max., controlled by attenuator.

8616A: +10 dBm (10 mW) to -127 dBm (0.1  $\mu$ V) into a 50-ohm load, 1800 to 3000 MHz; +3 dBm (2 mW) to -127 dBm (0.1  $\mu$ V) into a 50-ohm load, 3000 to 4500 MHz; output attenuator directly calibrated in dBm from 0 to -127 dBm.

8616B: at least 15 mW maximum, 1800 to 3000 MHz; at least 3 mW maximum, 3000 to 4500 MHz; controlled by attenuator.

**All models:** a second, uncalibrated rf output (approximately 0.5 mW) is provided on the front panel.

#### RF output power accuracy (with respect to attenuator dial)

8614A:  $\pm 0.75$  dB + attenuator accuracy from 0 to -127 dBm, including leveled output variations.

8616A:  $\pm 1$  dB + attenuator accuracy from 0 to -127 dBm, including leveled output variations.

#### Attenuator accuracy

8614A: +0, -3 dB from 0 to -15 dBm;  $\pm 0.2$  dB  $\pm 0.06$  dB/10 dB from -15 to -127 dBm.

8614B and 8616B:  $\pm 0.2$  dB  $\pm 0.06$  dB/10 dB below -10 dBm.

8616A: +0, -1 dB from 0 to -10 dBm;  $\pm 0.2$  dB  $\pm 0.06$  dB/10 dB from -10 to -127 dBm.

All models: direct-reading linear dial, 0.2 dB increments.

#### Internal impedance: 50 ohms nominal.

#### Reflection coefficient:

8614A: less than 0.33 (2.0 swr, 9.5 dB return loss).

8614B: less than 0.2 (1.5 swr, 14 dB return loss).

8616A: less than 0.33 (2.0 swr, 9.5 dB return loss).

8616B: less than 0.26 (1.7 swr, 11.7 dB return loss).

#### Modulation

**Internal square wave:** 950 to 1050 Hz.

**Square-wave sync:** square wave can be synchronized with a +1 to +10 volt signal applied to the Pulse input.

**External AM (8614A and 8616A only):** dc to 1 MHz.

**Incidental FM (8614A and 8616A only):** negligible for power levels below -10 dBm.

#### External pulse:

8614A and 8616A: 50 Hz to 50 kHz, 2  $\mu$ sec rise time, +20 to +100 volts input.

8614B and 8616B (below 4000 MHz): 50 Hz to 500 kHz; +25 to +50 volts peak input; minimum rf pulse width, 300 nsec; rf rise time, typically 200 nsec.

**External FM:** (a) front-panel connector capacitively coupled to klystron repeller; input impedance, 220 k $\Omega$ , shunted by approximately 300 pF; (b) rear-panel connector is dc-coupled to the klystron repeller.

**Power:** 115 or 230 volts  $\pm 10\%$ , 50 to 60 Hz, approximately 125 watts.

**Dimensions:** 16 $\frac{3}{4}$ " wide, 5 $\frac{1}{2}$ " high, 18 $\frac{3}{8}$ " deep (426 x 141 x 467 mm); hardware furnished for conversion to rack mount 19" wide, 5-7/32" high, 16 $\frac{3}{8}$ " deep behind panel (483 x 133 x 416 mm).

**Weight:** 8614A: net 42 lb (18.9 kg); shipping 48 lb (21.6 kg) 8614B and 8616B: net 38 lb (17.1 kg); shipping 43 lb (19.4 kg) 8616A: net 44 lb (19.8 kg); shipping 50 lb (22.5 kg).

**Price:** HP 8614A, \$2100; HP 8614B, \$1450; HP 8616A, \$2100; HP 8616B, \$1450.

**Option 01:** External modulation input connectors on rear panel in parallel with front-panel connectors; rf connectors on rear panel only; add \$25.



## UHF SIGNAL GENERATORS

Direct reading, direct control, 800 to 4200 MHz

Model 614A, 616B

Ease of operation, direct-reading one-dial frequency control, high stability and accuracy and broad frequency coverage are all advantages of these widely used signal generators.

The 614A covers frequencies from 800 to 2100 MHz, has constant internal impedance with less than 1.6 swr, and output accuracy of  $\pm 1$  dB over the range of  $-10$  dBm to  $-127$  dBm. The 616B gives complete coverage of frequencies from 1.8 to 4.2 GHz, has constant internal impedance with less than 1.8 swr, and output accuracy of  $\pm 1.5$  dB from  $-7$  dBm to  $-127$  dBm.

On both instruments, operation is extremely simple. Carrier frequency is set and read directly on the large tuning dial. No voltage adjustments are necessary during operation because of the coupling device which causes oscillator repeller voltage to track frequency changes automatically. Oscil-

lator output is set and read directly on a simplified dial. Output may be continuous or pulsed, or frequency modulated at power line frequency. Pulse modulation may be provided externally or internally. Internal pulsing may be synchronized with either positive or negative external pulses, or sine waves.

The oscillator portion of both the 614A and 616B consists of a reflex klystron in an external coaxial resonator. Frequency of oscillation is determined by a movable plunger which varies the resonant frequency of the resonator. Oscillator output is monitored by a temperature-compensated thermistor bridge circuit which is virtually unaffected by ambient temperature conditions. Voltage output is read directly. A logging scale on the frequency dial provides a resettability of 0.1%.

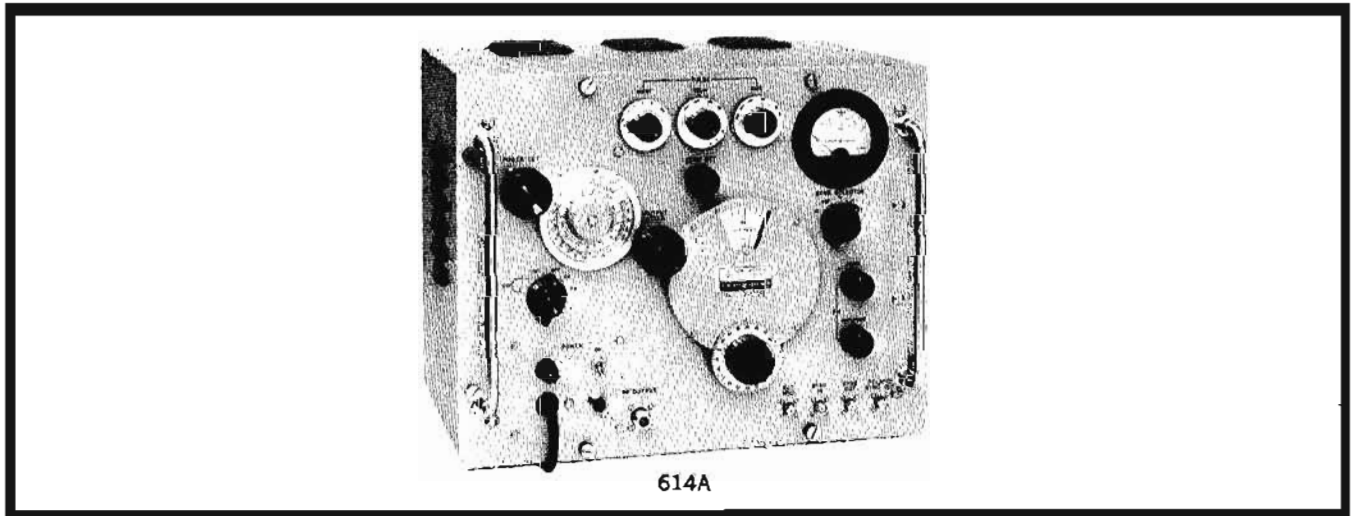

### Specifications

**Frequency range:** 614A, 800 to 2100 MHz; 616B, 1800 to 4200 MHz.

**Frequency accuracy:**  $\pm 1\%$ .

**Frequency stability:** 0.005%/°C change in ambient temperature; line voltage changes of  $\pm 10\%$  cause less than 0.01% frequency change.

**Output power range (into 50-ohm load):** 614A, 0.5 mW or 0.158 volt to 0.1  $\mu$ V ( $-3$  to  $-127$  dBm) from 800 to 900 MHz, 1 mW or 0.224 volt to 0.1  $\mu$ V (0 to  $-127$  dBm) from 900 to 2100 MHz; 616B, 1 mW or 0.224 volt to 0.1  $\mu$ V (0 to  $-127$  dBm).

**Power accuracy (at the end of 6 ft output cable, terminated in 50-ohm load):** 614A, within  $\pm 1$  dB from  $-10$  to  $-127$  dBm; 616B, within  $\pm 1.5$  dB from  $-7$  to  $-127$  dBm.

**Internal Impedance:** 614A, 50 ohms, reflection coefficient less than 0.23 (1.6 swr, 12.7 dB return loss); 616B, 50 ohms, reflection coefficient less than 0.285 (1.8 swr, 10.9 dB return loss).

**Modulation:** internal or external pulse or FM.

**Internal pulse modulation:** pulse repetition rate variable from 40 to 4000 per sec; pulse length variable from 1 to 10  $\mu$ sec; delay variable from 3 to 300  $\mu$ sec between synchronizing signal and rf pulse.

**External pulse modulation:** ext  $-$ :  $-40$  to  $-70$  V, 1 to 2500  $\mu$ sec wide, ext  $+$ :  $+40$  to  $+70$  V, 1 to 400  $\mu$ sec wide.

**Trigger pulses out:** (1) simultaneous with rf pulse; (2) in advance of rf pulse, variable from 3 to 300  $\mu$ sec (both approximately 1  $\mu$ sec rise time, amplitude  $+10$  to  $+30$  volts).

**External synchronization:** pulses,  $\pm 10$  to  $\pm 50$  volts, 1 to 20  $\mu$ sec wide; may also be synchronized with sine waves.

**Frequency modulation:** oscillator sweeps at power line frequency; deviation and phase adjustable; maximum deviation approx. 3 MHz p-p.

**RFI:** Conducted and radiated leakage limits are below those specified in MIL-I-6181D.

**Power:** 115 or 230 volts  $\pm 10\%$ , 50 to 400 Hz, approx. 160 watts.

**Dimensions:** cabinet:  $17\frac{1}{4}$ " wide,  $13\frac{3}{8}$ " high,  $13\frac{1}{2}$ " deep (438 x 346 x 343 mm); rack mount: 19" wide,  $13\text{-}31\text{/}32$ " high,  $12\frac{1}{8}$ " deep behind panel (483 x 355 x 308 mm).

**Weight:** net 59 lbs (26.5 kg); shipping 72 lbs (32.4 kg).

**Accessory furnished:** 11500A RF Cable Assembly.

**Accessories available:** 614A: 360C Low-Pass Filter,  $f_c = 2200$  MHz, \$65; 1053A Video Cable Assembly, \$6.50; 616B: S281A Waveguide-to-Coax Adapter, 2.6 to 3.95 gc, \$50; G281A Waveguide-to-Coax Adapter, 3.95 to 5.85 GHz, \$40; 360D Low-Pass Filter,  $f_c = 4.1$  GHz, \$60; 10503A Video Cable Assembly, \$6.50.

**Price:** HP 614A or hp 616B, \$1950 (cabinet); HP 614AR or HP 616BR, \$1970 (rack mount).

## MICROWAVE SYNCHRONIZERS

Generate highly stabilized microwave signals  
Models 2650A, 2654A



## SIGNAL SOURCES

These synchronizers permit absolute control of frequency by phase locking a klystron oscillator to a crystal reference, achieving essentially the stability of the references. The synchronizer introduces no frequency error. Instruments will stabilize most reflex klystrons, 1 to 12.4 GHz with complete elimination of klystron long-term drift and minimization of all incidental FM caused by klystron noise, power supply ripple and mechanical shock. Sideband noise is typically 70 dB down measured in any 1 kHz band from 3 kHz to beyond 100 kHz from the desired output frequency. Theory of operation of the 2650A is detailed on page 331; the 2654A operation involves similar principles.

The 2650A incorporates an internal crystal reference to stabilize klystron oscillator frequencies from 0.1 to 15.0 GHz and up to 40 GHz with standard modifications. The synchronizer samples less than 0 dBm of the klystron power. In addition, the 2650A permits frequency modulation of a klystron oscillator with deviations up to 500 kHz at rates from 0 to 50 kHz minimum. Higher rates may be achieved with the more sensitive klystrons. A front panel control permits manual timing of the klystron frequency over a 2 MHz range. The instrument may also be used to monitor a microwave signal frequency and provide a deviation frequency output for measurement by an electronic counter or frequency meter.

2654A Frequency Standard Synchronizer provides higher orders of signal stabilization by locking the signal source to a 5 MHz quartz oscillator. Yields stabilization essentially equal to the standard; for the 107AR this is  $< \pm 5/10^{10}/24$  hrs.

A version of the 2654A is available to lock microwave sources to harmonics of the 5100A Frequency Synthesizer. This technique provides signal stabilities with typical rms frequency deviation of  $2/10^{11}/\text{sec}$ .

Both the 2650A and 2654A are available as individual instruments to be coupled by the user with a klystron, power

supply and, if applicable, an external frequency reference, such as a quartz oscillator. They are also available as complete, fully specified frequency generation systems. A choice of klystrons is available for these systems, covering all or part of the 8.2 to 12.4 GHz range, at output powers from 30 to 500 mW.

### Specifications, 2650A

- Input frequency:** 1 to 12.4 GHz.  
**Stability** (using internal crystal):  $1/10^8$  per second,  $1/10^9$  per week (over  $\pm 5^\circ\text{C}$ ),  $1/10^8$  over range 0 to  $50^\circ\text{C}$ .  
**Output circuitry:** suitable for connection to klystron reflector; floating and insulated up to 2000 V dc; a phase lag network provides optimum characteristics for matching klystron sensitivities to 4 MHz/V.  
**Input power:** 0 dBm at 12.4 GHz less at lower frequencies; maximum power input, +20 dBm.  
**RF reference:** internal: provided by internal quartz crystal, 100 MHz standard, others on special order; external: 100 to 400 MHz, 2 V into 50 ohms.  
**IF reference:** internal: quartz crystal 10 MHz  $\pm 0.001\%$  of VFO tunable 29 to 31 MHz by front-panel control; external: 29 MHz to 31 MHz, 0.5 V into 56 k $\Omega$ , also 10 MHz at higher levels.  
**Power:** 115 or 230 V  $\pm 10\%$ , 50 to 1000 Hz, 85 W.  
**Dimensions:** 16 $\frac{3}{4}$ " wide, 5 $\frac{1}{4}$ " high, 16 $\frac{3}{8}$ " deep behind panel (425 x 133 x 416 mm); hardware furnished converts unit to 19" wide rack mount.  
**Weight:** net 21 lbs (9.5 kg); shipping 35 lbs (15.9 kg).  
**Price:** 2650A, \$1450 (supplied with 100 MHz rf reference crystal; with special order crystal, \$1480).

### Specifications, 2654A

(same as 2650A except)

- Stability:** equal to external oscillator (with 107AR, BR,  $2/10^{11}$  rms averaged over 1 sec,  $5/10^{10}$  per 24 hours).  
**RF reference, IF reference:** taken from quartz oscillator.  
**Price:** 2654A, \$2000.

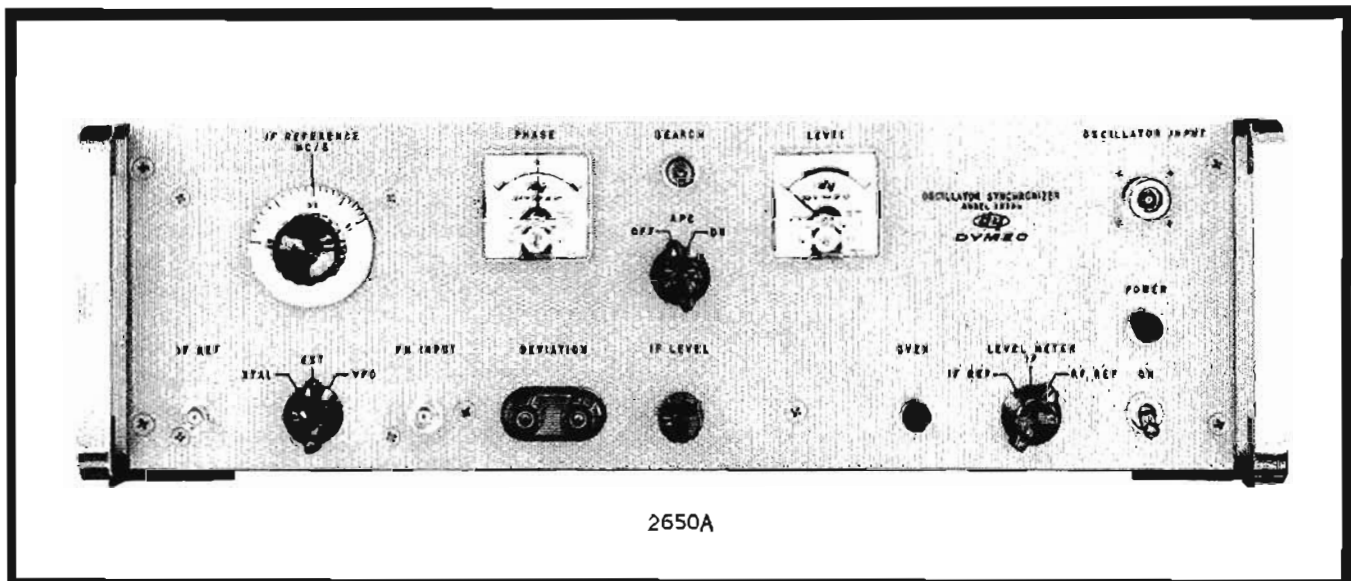

2650A





## SHF SIGNAL GENERATORS

Multiple-purpose instruments, 3.8 to 11 GHz  
Models 618C, 620B

**Advantages:**

- Direct-reading frequency dial
- Direct-reading output in voltage or dBm
- Internal FM, CW, pulsed or square-wave modulation
- Broadband coverage
- Wide frequency range
- High stability, high accuracy

**Use to measure:**

- Receiver sensitivity
- Selectivity or rejection
- Signal-to-noise ratio
- Antenna gain
- Transmission line characteristics

The Models 618C and 620B SHF Signal Generators provide versatility, accuracy, and stability in the range from 3.8 to 11 GHz. Thus such measurements as sensitivity, selectivity, signal-to-noise ratio, swr, and antenna gain are made with ease. Frequency is set on a large, direct-reading dial. A  $\Delta F$  vernier control provides ultra-fine tuning capability. There is also a provision for remote fine tuning.

A calibrated output from 0 to  $-127$  dBm (0.224 volts to 0.1 microvolt) is also set on a large, direct-reading dial. The dial is calibrated in both dBm and volts, permitting measurements in terms of either and eliminating any computation in converting from one to the other. In addition, the zero set control for the power monitor has been eliminated, simplifying measurements by reducing the number of steps required. A second, uncalibrated output is available. This auxiliary output is at least 0.3 milliwatt and is independent of attenuator setting. Thus it can be used for phase locking the signal generator when crystal-oscillator stability is required, or it can be monitored with a frequency counter for extreme frequency resolution.

**Reflex klystron oscillator**

The 618C and 620B Generators both feature oscillators of the reflex klystron type, with external resonant cavity. Oscillator frequency is determined by a movable plunger which varies the length of the cavity. Oscillator output is monitored by a temperature-compensated detector circuit. This circuit operates virtually unaffected by ambient temperature conditions. Identical piston attenuators couple power to the monitor and output terminal. The power monitor attenuator is linked to the output attenuator cursor to compensate for klystron output variation as frequency is changed.

**Broad modulation capabilities**

Modulation includes internal pulse, square-wave, and frequency modulation plus external pulse and frequency modulation. Internal pulse and square-wave repetition rates are continuously variable from 40 to 4000 pps, and pulse width is variable from 0.5 to 10 microseconds. Synchronization pulses are available simultaneously with the rf pulse or in

advance of the rf pulse from 3 to 300 microseconds. The internal pulse and square-wave modulation can be synchronized with external sine waves or pulses of either polarity, or external pulses can themselves be used as the modulating signal.

For internal frequency modulation, each generator has a sawtooth sweep variable from 40 to 4000 Hz with deviation adjustable up to about 5 MHz peak-to-peak. External FM is accomplished through one of two input connectors. The front-panel input is capacitively coupled to the repeller of the klystron oscillator for standard FM applications. The rear-panel input is dc coupled to the klystron to permit phase locking of the oscillator. The HP 2650A Oscillator Synchronizer is ideal for this purpose.

**Specifications****Output**

**Frequency Range:** 618C: 3,800 to 7,600 MHz covered in a single band; 620B: 7 to 11 GHz covered in a single band; repeller voltage automatically tracked and proper mode automatically selected.

**Calibration:** direct reading; frequency calibration accuracy better than  $\pm 1\%$ .

**Vernier:**  $\Delta F$  control has a minimum range of 1.5 MHz for fine tuning; remote  $\Delta F$  connector on rear panel permits fine tuning with external potentiometer; tuning range at least 1.5 MHz with potentiometer  $\geq 2$  megohms.

**Frequency stability:** with temperature: less than 0.006%/°C change in ambient temperature; with line voltage: less than 0.02% change for line voltage variation of  $\pm 10\%$ ; residual FM: 618C,  $< 8$  kHz peak-to-peak; 620B,  $< 10$  kHz peak-to-peak.

**Output range:** 1 milliwatt or 0.224 volt to 0.1 microvolt (0 dBm to  $-127$  dBm) into 50 ohms; directly calibrated in microvolts and dB; coaxial type N connector.

**Output accuracy:** within  $\pm 2$  dB from  $-7$  to  $-127$  dBm, within  $\pm 3$  dB from 0 to  $-7$  dBm, terminated in 50-ohm load; temperature-compensated detector circuit monitors rf oscillator power level; an auxiliary, fixed-level rf output (at least 0.3 mW) is provided on the front panel for use with other equipment such as HP 2650A Oscillator Synchronizer or a frequency counter.

**Source Impedance:** 50 ohms nominal; reflection coefficient less than 0.33 (2 swr, 9.6 dB return loss).

**Modulation**

**Modulation:** internal or external pulse, FM, and square wave.

**Internal pulse modulation:** repetition rate variable from 40 to 4,000 pps, pulse width variable  $\frac{1}{2}$  to 10 microseconds.

**Sync out signals:** simultaneous with rf pulse, positive; in advance of rf pulse, positive, variable 3 to 300 microseconds (better than 1 microsecond rise time and 25 to 100 volts amplitude into 1,000-ohm load).



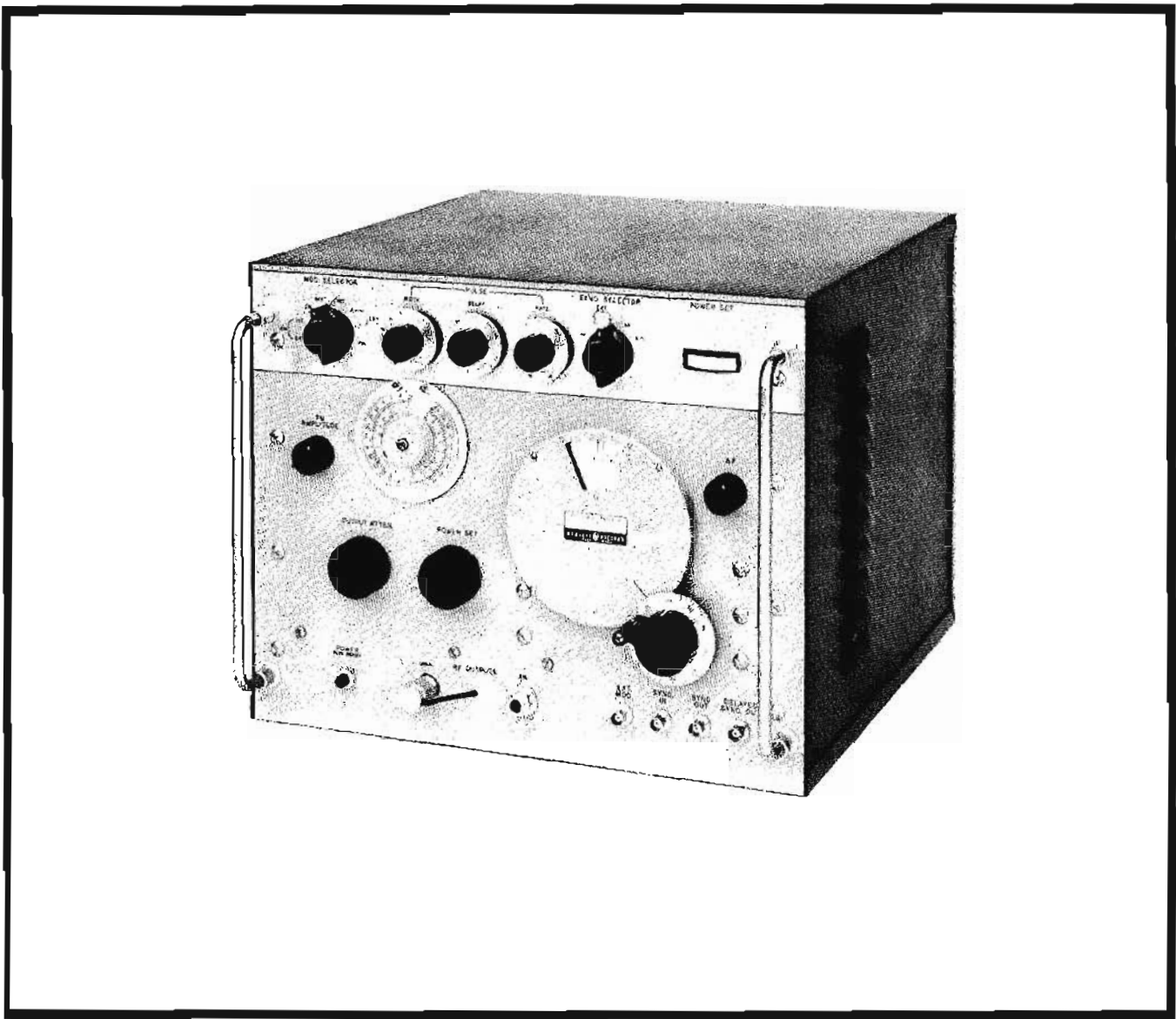

**External synchronization:** sine wave: 40 to 4,000 Hz, 5 to 50 V rms; pulse: 40 to 4,000 pps, 5 to 50 V peak, positive or negative, 0.5 to 5  $\mu$ sec wide, 0.1 to 1  $\mu$ sec rise time.

**Internal square wave modulation:** variable 40 to 4,000 Hz, controlled by "pulse rate" control.

**Internal frequency modulation:** sawtooth sweep rate adjustable 40 to 4,000 Hz; frequency deviation to 5 MHz peak-to-peak over most of the frequency range.

**External pulse modulation:** pulse requirements: amplitude from 5 to 50 volts positive or negative, width 0.5 to 2,500 microseconds.

**External FM:** frequency deviation approximately 5 MHz peak-to-peak over most of the band; sensitivity approximately 20 V/MHz at front-panel connector, approximately 10 V/MHz at rear panel connector (mating connector supplied); front-panel connector is capacitively coupled to klystron repeller; rear-panel connector is dc coupled to klystron repeller and is suitable for phase-lock control input from HP 2650A Oscillator Synchronizer.

### General

**RFI:** conducted and radiated leakage limits are below those specified in MIL-I-6181D.

**Power source:** 115 or 230 volts  $\pm 10\%$ , 50 to 400 Hz, 180 watts.

**Dimensions:** cabinet: 17 $\frac{1}{2}$  in. wide, 13 $\frac{7}{8}$  in. high, 17 $\frac{3}{8}$  in. deep behind panel (445 x 353 x 441 mm); rack mount: 19 in. wide, 13 $\frac{3}{4}$  in. high, 17 $\frac{3}{8}$  in. deep behind panel (483 x 355 x 441 mm).

**Weight:** net, 63 lbs (29 kg); shipping 87 lbs. (39 kg).

**Accessory furnished:** 11500A Cable Assembly, 6 feet (1830 mm) of specially treated RG-214A/U 50-ohm Coax, terminated on each end by type N male connectors, \$6.50.

**Price:** Model 618C (cabinet mount), \$2,250. Model 618CR (rack mount), \$2,270. Model 620B (cabinet mount), \$2,250. Model 620BR (rack mount), \$2,270.



## SHF SIGNAL GENERATORS

Direct reading, high power, 10 to 21 GHz  
Models 626A, 628A

### Advantages:

- Direct-reading frequency control
- Direct-reading output control
- 10 mW output over full range
- CW, FM or pulse modulation
- Internal square-wave modulation
- Broad pulsing capabilities
- Low internal swr
- High stability
- Operate to 40 GHz with HP 938, 940 Frequency Doubler Sets

### Use to measure:

- Receiver sensitivity
- Selectivity or rejection
- Signal-to-noise ratio
- Transmission line characteristics

Here are two HP signal generators which extend the measuring versatility, convenience and accuracy of HP VHF signal generators to 21 GHz. The 626A covers frequencies 10 to 15.5 GHz, and the 628A covers frequencies 15 to 21 GHz. In design and operation, the instruments are similar to HP generators for lower frequency ranges. Operation is very simple. Carrier frequency is set and read directly on the large tuning dial. No voltage adjustment is necessary during tuning because repeller voltage is tracked with frequency changes automatically. Oscillator output also is set and read directly, and no frequency correction is necessary throughout operating range. A frequency logging scale permits frequency to be reset within 0.1%.

The high power output of these signal generators make them ideally suited for driving HP 938A and 940A Frequency Doubler Sets (18 to 26.5 GHz and 26.5 to 40 GHz respectively). These doubler sets retain the modulation and stability of the driving source and have accurate power monitors and attenuators.

### Versatile modulation

Both the 626A and 628A offer internal and external pulse modulation, as well as internal square-wave modulation and FM. Pulse repetition rate is continuously variable from 40 to 4000 pps, and pulse width is variable from 0.5 to 10  $\mu$ sec. Sync out signals are simultaneous with the rf pulse, or in advance of the rf pulse by any time span from 3 to 300  $\mu$ sec. The pulse generators may be synchronized with an external sine wave and also with positive or negative pulse signals.

For internal FM, both instruments feature a sine wave sweep at power line frequency. Frequency deviation is variable up to 10 MHz peak-to-peak. For external FM, the generators have capacitive couplings to the klystron oscillator repeller.

Figure 1 shows the basic circuits of the HP signal generators. The reflex klystron oscillator is tuned by a plunger driven by the direct-reading frequency dial and control. Repeller voltage is automatically tracked, so that correct operating potentials are maintained over the entire frequency range. Klystron output is introduced into a power monitoring meter. The directional coupler provides uniform coupling over the entire frequency range. A rotary attenuator which follows the coupler assures high accuracy and stability, because the attenuation is governed by a precise

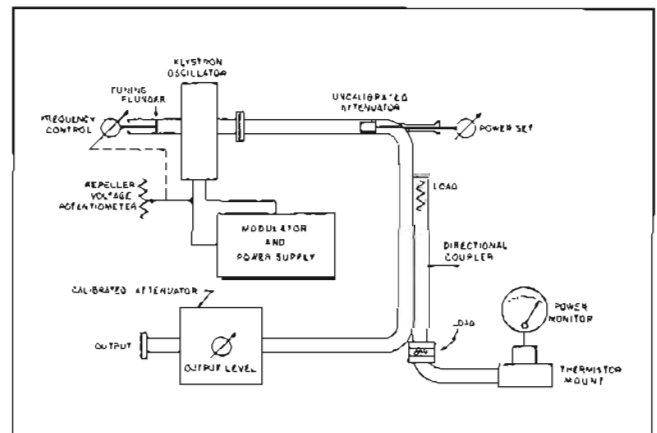

Figure 1. Basic circuit, HP 626A, 628A.

mathematical law related to the angular rotation of the attenuator. The conductivity of the attenuating film does not affect the attenuation; thus, the output of the generator is independent of humidity, temperature or the effect of long-term aging. The attenuator also provides low swr over the complete frequency range. On both HP 626A and 628A, the output connector is waveguide. Adapters furnished permit the instruments to be connected to WR-42, WR-62 or WR-90 waveguide. Thus, the generators can be employed with all EIA (RETMA) and JAN guides suitable for the 10 to 21 GHz range.

### Specifications

**Frequency range:** 626A, 10 to 15.5 GHz; 628A, 15 to 21 GHz.

**Frequency calibration:** dial direct reading in gigacycles; accuracy better than  $\pm 1\%$ .

**Output range:** 10 mW to pW (+10 dBm to -90 dBm, 0 dBm = 1 mW); attenuator dial directly calibrated in output dBm.

**Source impedance:** 50 ohms nominal; reflection coefficient: 626A, less than 0.43 (2.5 swr, 7.3 dB return loss) at +10 dBm, 0.15 (1.35 swr, 16.5 dB return loss) at 0 dBm and below; 628A, less than 0.43 (2.5 swr, 7.3 dB return loss) at +10 dBm, 0.091 (1.2 swr, 20.8 dB return loss) at 0 dBm and below.

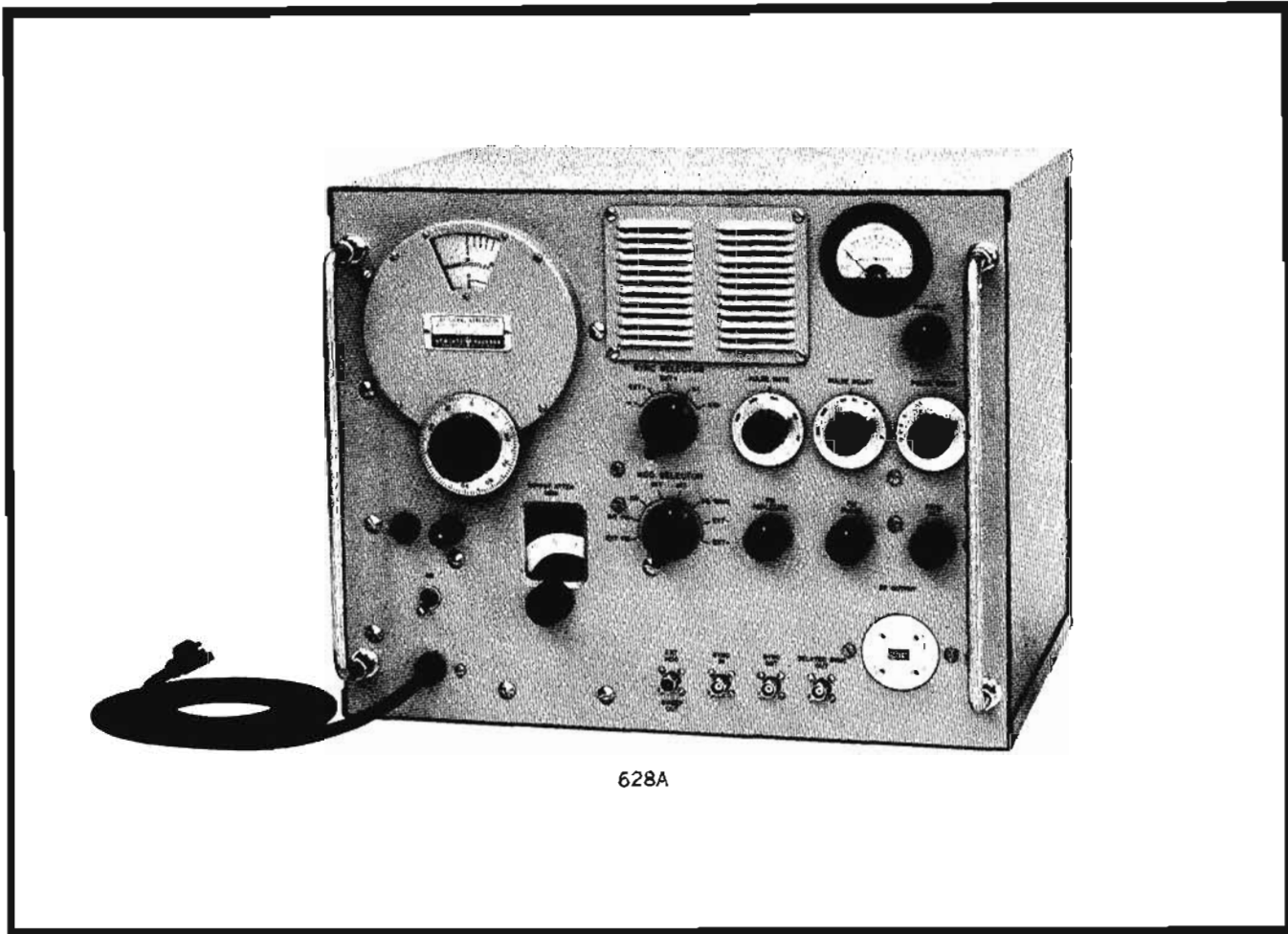

628A

**Output monitor accuracy:** better than  $\pm 1$  dB; temperature-compensated thermistor bridge circuit monitors rf oscillator power level.

**Output connector:** 626A: 0.850 x 0.475 in. waveguide, WR75, flat cover flange; 628A: 0.590 x 0.335 in. waveguide, WR51, flat cover flange.

**Output attenuator accuracy:** better than  $\pm 2\%$  of attenuation in dB introduced by output attenuator.

**Leakage:** less than minimum calibrated signal generator output.

**Modulation:** internal or external pulsed, FM, or square-wave.

**Internal pulse modulation:** repetition rate variable from 40 to 4000 pps; pulse width variable 0.5 to 10  $\mu$ sec.

**Internal square-wave modulation:** variable 40 to 4000 Hz controlled by "pulse rate" control.

**Internal frequency modulation:** power line frequency, deviation up to 10 MHz p-p.

**External pulse modulation:** pulse requirements: amplitude 15 to 70 volts peak positive or negative; width 1 to 2500  $\mu$ sec.

**External frequency modulation:** provided by capacitive coupling to repeller of klystron; maximum deviation approximately 10 MHz p-p.

**Sync out signals:** positive 20 to 50 volts peak into 1000-ohm load; better than 1  $\mu$ sec rise time; (1) simultaneous with rf pulse, positive; (2) in advance of rf pulse, positive, variable 3 to 300  $\mu$ sec.

**External synchronization:** (1) sine wave, 40 to 4000 Hz, amplitude 5 to 50 volts rms; (2) pulse signals 0 to 4000 pps, 5 to 50 volts amplitude, positive or negative; pulse width 0.5 to 5  $\mu$ sec; rise time 0.1 to 1  $\mu$ sec.

**Power:** 115 or 230 volts  $\pm 10\%$ , 50 to 60 Hz approx. 200 watts.

**Dimensions:** cabinet: 17" wide, 14" high, 15" deep (432 x 356 x 381 mm); rack mount: 19" wide, 14" high, 12-13/16" deep behind panel (483 x 356 x 313 mm).

**Weight:** 626A,AR: net 61 lbs (28,1 kg), shipping 76 lbs (35 kg); 628A,AR: net 57 lbs (26,4 kg), shipping 72 lbs (33,1 kg).

**Accessories furnished:** 626A (a) MX 292B Waveguide Adapter, WR-75-to-WR-90 guide; (b) MP 292B Waveguide Adapter, WR-75-to-WR-62 guide; 628A (a) NP 292A Waveguide Adapter, WR-51-to-WR-62 guide; (b) NK 292A Waveguide Adapter, WR-51-to-WR-42 guide.

**Accessories available:** 10503A Video Cable Assembly, \$6.50; for 626A: M362A Low-Pass Filter, \$350.

**Price:** HP 626A or 628A, \$3400 (cabinet); HP 626AR or 628AR, \$3420 (rack mount).



## FREQUENCY DOUBLER SETS

Generate stable signals to 40 GHz

Models 938A, 940A

Hewlett-Packard Model 938A and Model 940A Frequency Doubler Sets bring you low-cost signal-generation capability in K- and R-bands (18 to 40 GHz). Model 938A supplies power from 18 to 26.5 GHz when it is driven by a 9 to 13.25 GHz source; Model 940A supplies power from 26.5 to 40 GHz when it is driven by a 13.25 to 20 GHz source.

These frequency doubler sets consist of broadband crystal harmonic generators suitably mounted in a waveguide section, a power monitor, a broad stopband low-pass filter and a precision attenuator. They may be driven by klystrons, by signal generators, such as HP Models 626A and 628A or by sweep oscillators such as HP Model 8690A with 8694A,B or 8695A RF Units.

Since Model 938A and Model 940A are broadband instruments, the input signal may be cw, pulsed or swept. Thus, the frequency doubler sets retain all the versatility of the driving source.

### Output monitor

Models 938A and 940A have power monitors and pre-

cision rotary-vane attenuators for accurately setting output level over a range from 0 to -100 dB. Output power depends on input power and is typically 0.5 to 1 mW when a 626A, 628A, or 8690A is used as a driving source. Further, since Models 938A and 940A contain a power monitor, output power is known even though an uncalibrated signal source is used.

### Signal generator or swept-frequency operation

Models 938A and 940A have the same output versatility as the driving source. For instance, if you drive Model 938A with Model 626A you may have cw output, pulse-modulated output with a repetition rate from 40 to 4000 pps, square-wave modulated output with modulation frequencies from 40 to 4000 Hz, or 60 Hz (power line frequency) FM output. In addition, pulsed output may be synchronized with external signals or output may be externally pulse or frequency modulated.

To obtain a swept-frequency output, you simply drive the frequency doubler set from a swept-frequency source such as Model 8690A with 8694 A,B or 8695A RF Unit.



938A

### Specifications

**Frequency range:** 938A, 18 to 26.5 GHz, 940A, 26.5 to 40 GHz.

**Conversion loss:** less than 18 dB at 10 mW input.

**Output power:** depends on input power supplied; approx. 0.5-1 mW when used with typical 626A, 628A Signal Generators.

**Input power required:** 10 mW design center.

**Maximum input power:** 100 mW.

**Output monitor accuracy:**  $\pm 2$  dB.

**Output attenuator accuracy:**  $\pm 2\%$  of reading or  $\pm 0.2$  dB, whichever is greater.

**Attenuator range:** 100 dB.

**Output reflection coefficient:** approximately 0.33 (2 swr, 9.5 dB return loss) at full output; less than 0.2 (1.5 swr, 14 dB return loss) with attenuator set to 10 dB or more attenuation.

**Input flange:** 938A, M-band flat cover flange for WR-75 waveguide; 940A, N-band flat cover flange for WR-51 waveguide.

**Output flange:** 938A, UG-595/U flat cover flange for WR-42 waveguide (K-band); 940A, UG-599/U flat cover flange for WR-28 waveguide (R-band).

**Dimensions:** cabinet: 19 $\frac{1}{4}$ " wide, 5 $\frac{3}{8}$ " high, 18" deep (489 x 137 x 457 mm); rack mount: 19" wide, 5-7/32" high, 16 $\frac{1}{2}$ " deep behind panel (483 x 133 x 419 mm).

**Weight:** net 20 lbs (9 kg); shipping 35 lbs (15.8 kg).

**Accessories available:** 938A, X281A Waveguide-to-Coax Adapter, 8.2 to 12.4 gc, \$25; MX292B and MP292B Waveguide-to-Waveguide Adapters, \$50 and \$40 respectively (1 each furnished with 626A); 11504A X-band Flexible Waveguide, \$35; 11503A P-band Flexible Waveguide, \$48; 940A, MP292B and NP292A Waveguide-to-Waveguide Adapters, \$40 each (1 each furnished with 628A); 11503A P-band Flexible Waveguide, \$48.

**Complementary equipment:** 938A, 626A Signal Generator; 8690A Sweep Oscillator with 8694A,B and 8695A RF Unit. 940A, 626A and 628A Signal Generators; 8690A Sweep Oscillator with 8695A RF Unit.

**Price:** HP 938A or HP 940A, \$1700 (cabinet); HP 938AR or HP 940AR, \$1720 (rack mount).

## RF TEST SETS

For testing transmitters, receivers  
Models 623B, 624C, 5636



## SIGNAL SOURCES

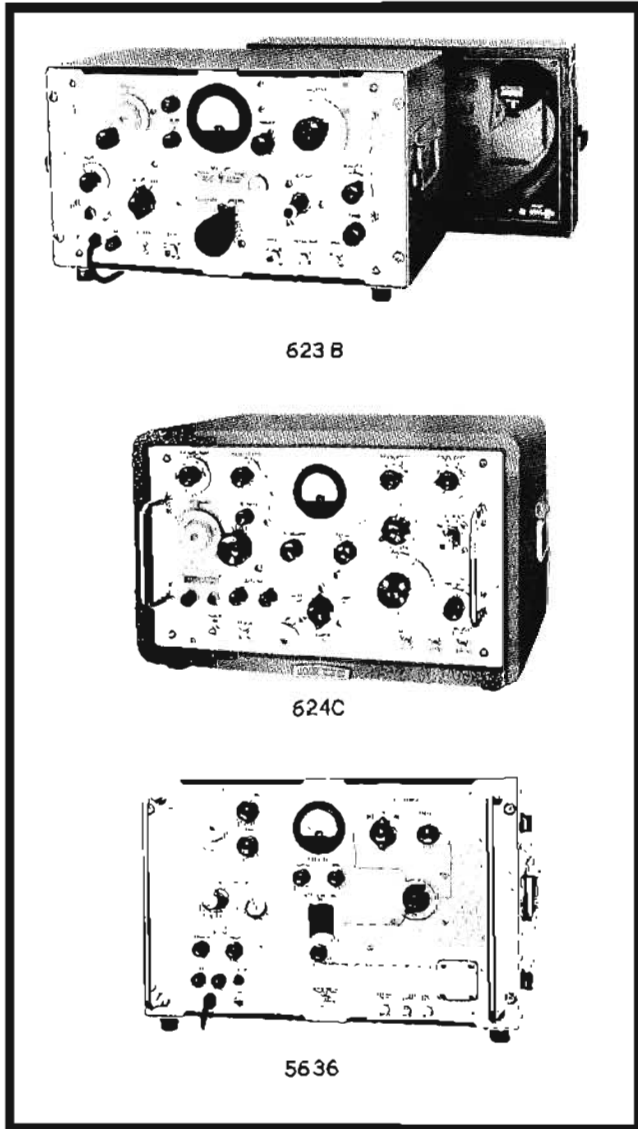

623 B

624C

5636

### Advantages:

- Direct reading of power, frequency
- Stable accurate input, output attenuators
- Compact package for easy portability in field

### Uses:

- Measure receiver sensitivity, selectivity
- Test transmitter tuning power level

Each of these test instruments consists of a combination signal generator, frequency meter and power meter and permits measurement of receiver sensitivity and selectivity, transmitter tuning and power level. Each is easy to use, fast and accurate.

The HP model 623B SHF Test Set is an ideal one-piece unit for measuring receiver sensitivity or selectivity, transmitter tuning or power level. It is particularly adapted to testing complete communications, control, and video relay station equipment in the range of 5925 to 7750 MHz, using any of 3 klystrons. Its klystron source can be frequency modulated internally, or externally pulse modulated.

From 8.5 to 10.0 GHz, the 624 X-Band Test Set provides a one-piece unit particularly adaptable for testing complete radar, gunfire control systems, or radio beacon equipment. It has internal frequency modulation capability to 1 kHz and provision for a 30 Hz to 3.5 kHz pulse, FM, or square wave external modulation.

Overlapping the frequency ranges of the 623B and 624C, the 5636 H-Band-Test Set more than covers the entire government communications band. It performs the same task but offers greater output power and a wider power measurement range than the 623B and 624C.

### Specifications

Model	Frequency range (MHz)	Frequency meter range (MHz)	Output power (dBm)	Output attenuator range (dB)	Internal modulation	External modulation	Power measurement range (CW)	Panel height	Price
623B	5925-6575 or 6575-7175 or 7125-7750	5820-7780	0 (1 mW)	70	FM, 1 kHz	FM, pulse, square-wave, 30 Hz to 100 kHz	-6 to +3 dBm	11½" (292 mm)	\$2250 (transit case)
5636	7100-8500	7100-8500	15 (30 mW)	100	FM, 1 kHz	FM, pulse, square-wave, 30 Hz to 100 kHz	-6 to +40 dBm	14" (355 mm)	\$4250 (transit case)
624C	8500-10,000	8500-10,000	0 (1 mW)	100	FM, power line frequency; pulse, 35 to 3500 pps	FM, pulse, square-wave, 35 to 3500 Hz	-6 to +28 dBm	10½" (266 mm)	\$2265 (cabinet) \$2250 (rack mount)



## SPECTRUM GENERATOR/DOUBLER

Versatile broadband operation  
Models 10511A, 10515A

## HP 10511A Spectrum Generator

The Hewlett-Packard 10511A Spectrum Generator is a passive device that generates a train of 1 nanosec wide pulses when driven by a sinusoidal signal source. The 10511A was specifically designed as an accessory to the HP 5100A Frequency Synthesizer. However, it is useful with any 50-ohm source that can provide the proper input signal.

With a sine wave input, in the frequency range of 10 MHz to 75 MHz, a spectrum of harmonics is generated. This spectrum contains all harmonics of the input frequency to the 1 GHz region. To extract a desired harmonic, a 50-ohm bandpass filter can be cascaded with the 10511A to give a sinusoidal output. The HP 230A Power Amplifier (tuned) may be used for higher level outputs for harmonics up to 500 MHz.

Operation of the 10511A with the 5100A without a bandpass filter on the output produces a pulse train whose repetition rate is precisely controlled. The 10511A, with a tuned filter, produces precise CW frequencies between 50 MHz and 500 MHz.

## Specifications 10511A

## Input requirements

Frequency range: 25 to 50 MHz.\*

Drive level: 1 to 3 volts RMS available to 50 ohm.

## Output

Pulse width: 1 nanosecond,  $\pm 15\%$  at mid-amplitude.

Pulse height: 0.75 volt minimum for minimum drive level.

Impedance: 50 ohm (nominal).

Available harmonic power:  $-19$  dBm minimum for any harmonic number between 1 and 10.

## General

Dimensions: 3 in. long,  $1\frac{5}{8}$  in. dia. (76 x 41 mm).

Weight: net, 3 oz (85 grams). Shipping, 1 lb (0.45 kg).

Price: \$150.

\*Useful operation is obtained for input frequencies from 10 MHz to 75 MHz.

## HP 10515A Frequency Doubler

The Hewlett-Packard Model 10515A Frequency Doubler is an ideal accessory for use in extending the usable frequency range of signal generators, frequency synthesizers or other signal sources. Operating on input frequencies of 0.5 MHz to 500 MHz it provides a doubled output in the range of 1 MHz to 1 GHz. This 50 ohm device uses a full-wave rectifier circuit which is extremely flat over its entire frequency range. The frequency response is very flat ( $< \pm 1$  dB over entire range typically), and undesired harmonics are very well suppressed.

The output of this unit does not have an internal dc return so that it will provide a very broadband ac to dc conversion only if not dc terminated. This mode of operation is useful for detection of low level amplitude modulations.

The 10515A may be used with the following Hewlett-Packard instruments (this is only a partial listing):

5100A Frequency Synthesizer	606A Signal Generator
5102A Frequency Synthesizer	3200A VHF Oscillator
5103A Frequency Synthesizer	608 Signal Generators

## Specifications 10515A

Frequency range: 0.5-500 MHz input; 1-1000 MHz output.

Impedance: 50 ohm nominal (source and load).

Input signal voltage: 0.5 - 3.0  $V_{RMS}$ .

Input signal power: 180 mW (maximum).

Conversion loss:\*

$< 12$  dB (typically  $< 11$  dB) for  $> 1$  volt

$< 13$  dB (typically  $< 12$  dB) for  $> 0.5$  volt

Suppression of 1st and 3rd harmonic of input:\*

$> 30$  dB for 0.5 to 50 MHz input (typically  $> 35$  dB).

$> 20$  dB for input to 500 MHz (typically  $> 25$  dB).

Connectors: input: BNC male; output: BNC female.

Dimensions: diameter: 0.7" (18 mm); length: 2.5" (64 mm).

Weight: approximately 2 oz (56 grams).

Price: \$120.

\*With a 50 ohm resistive load and a single input frequency. Suppression values are referred to the desired output level.

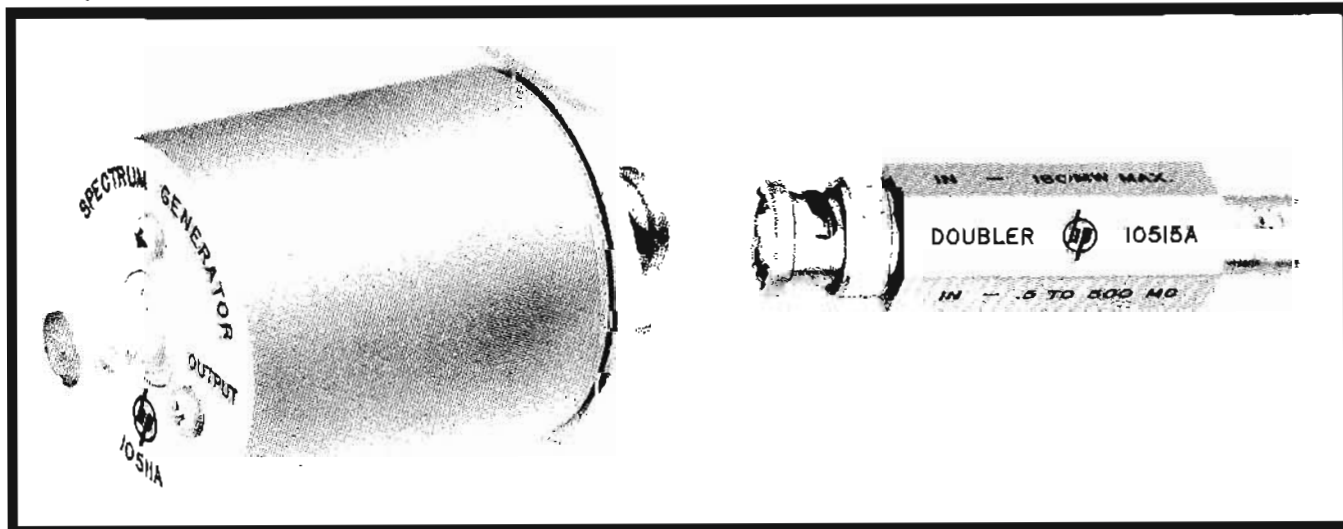

# FM-AM SIGNAL GENERATOR

FM, AM, CW and pulse coverage 54 to 216 MHz  
Model 202H



## SIGNAL SOURCES

The HP 202H FM-AM Signal Generator covers the frequency range from 54 to 216 MHz and is designed for the testing and calibration of FM receiving systems in the areas of broadcast FM, vhf, tv, mobile and general communica-

tions. The generator consists of a three-stage rf unit, together with a modulating oscillator and power supply, all housed in a single cabinet which may be readily adapted for rack mounting.

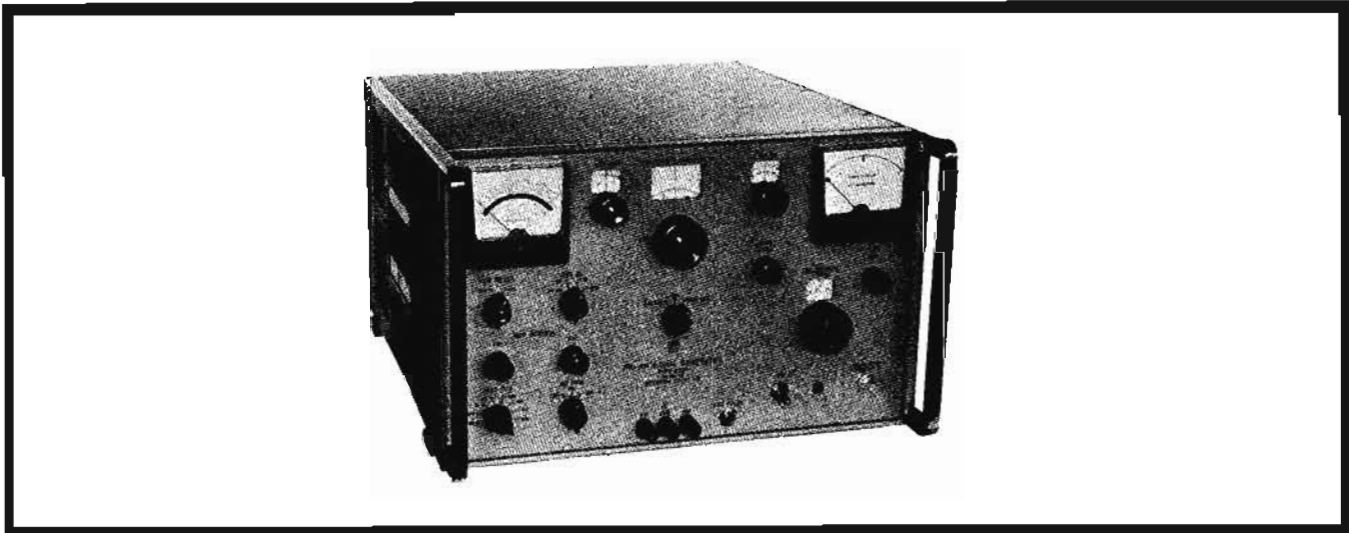

### Specifications

#### Radio frequency characteristics

**RF range:** total range: 54 to 216 MHz; number bands: 2; band ranges: 54 to 108 MHz 108 to 216 MHz.  
**RF accuracy (after 1 hour warm-up):** main dial:  $\pm 0.5\%$ ; electronic vernier:  $\pm (10\% + 1 \text{ kHz})$ .  
**RF stability:**  $< 0.01\%$  per hour (after two hour warm-up).  
**RF output:** range:  $0.1 \mu\text{V}$  to  $0.2 \text{ V}$  (across external 50-ohm load at panel jack); accuracy:  $\pm 10\%$ ,  $0.1 \mu\text{V}$  to  $50 \text{ K} \mu\text{V}$ ;  $\pm 20\%$ ,  $50 \text{ K} \mu\text{V}$  to  $0.2 \text{ volts}$ ; Auto level set: holds rf monitor meter to "red line" over band.  
**Impedance:** 50 ohms.

**VSWR:**  $< 1.2$ .

**Spurious output:** All spurious rf output voltages are at least 30 dB below desired fundamental.

**RF leakage:** sufficiently low to permit measurements at  $0.1 \mu\text{V}$ .

#### Amplitude modulation characteristics

**AM range:** internal: 0 to 50%; external: 0 to 100%.  
**AM accuracy:**  $\pm 10\%$  of reading at 400 Hz at 30% and 50% AM.  
**AM calibration:** 30, 50, 100%.  
**AM distortion:**  $< 5\%$  at 30%,  $< 8\%$  at 50%,  $< 20\%$  at 90%.  
**AM fidelity:**  $\pm 1 \text{ dB}$ , 30 Hz to 200 kHz.

**External AM requirements:** approximately 60 volts rms into 500 ohms for 100% AM.

#### Frequency modulation characteristics

**FM deviation range:** internal or external, 0 to 250 kHz in 4 ranges.

**FM deviation accuracy:**  $\pm 5\%$  of full-scale (for 400 Hz sine wave).

**FM calibration:** 0 to 7.5 kHz in increments of 0.5 kHz, 0 to 25 kHz in increments of 1 kHz, 0 to 75 kHz in increments of 5 kHz, 0 to 250 kHz in increments of 10 kHz.

**FM distortion (at 400 Hz mod. freq.):**  $< 0.5\%$  at 75 kHz (100 MHz),  $< 1\%$  at 75 kHz (54 to 216 MHz),  $< 10\%$  at 250 kHz (54 to 216 MHz).

**FM fidelity:**  $\pm 1 \text{ dB}$ , 5 Hz to 200 kHz.

**Signal-to-noise ratio:**  $> 50 \text{ dB}$  below 10 kHz (31.6 Hz peak deviation).

**External FM requirements:**  $< 3 \text{ volts rms}$  into 2 K ohms for 250 kHz deviation.

**DC FM input:** permits control of output frequency over a limited range with an external dc voltage.

#### Pulse modulation characteristics

**PM source:** external, PM rise time:  $\leq 0.6 \mu\text{sec}$ .

**PM decay time:**  $< 0.8 \mu\text{sec}$ .

#### Modulating oscillator characteristics

**OSC frequency:** 50 Hz, 400 Hz, 1000 Hz, 3000 Hz, 7.5 kHz, 10 kHz, 15 kHz, 67 kHz.

**OSC accuracy:**  $\pm 5\%$ .

**OSC distortion (at FM terminals):**  $< 0.5\%$ , 50 Hz to 15 kHz;  $< 1.0\%$ , 67 kHz.

#### Physical characteristics

**Dimensions:**  $16\frac{3}{4}$ " wide,  $10\frac{1}{4}$ " high,  $18\frac{3}{8}$ " deep (425 x 260 x 467 mm).

**Weight:** net 45 lbs (20.3 kg), shipping 60 lbs (27 kg).

**Power:** 105 to 125 or 210 to 250 V, 50 to 400 Hz, 100 W.

**Accessory furnished:** 00502B Patching Cable.

**Price:** HP 202H, \$1475.





## TELEMETER TEST GENERATOR

FM, AM, CW and pulse coverage, 195 to 270 MHz  
Model 202J

The HP 202J Telemetry Signal Generator covers the frequency range from 195 to 270 MHz and is designed for the testing and calibration of FM telemetry receiving systems in the 215 to 260 MHz band.

The generator consists of a three-stage rf unit, together with a modulating oscillator and power supply, all housed in a single cabinet which may be readily adapted for rack mounting.



### Specifications

#### Radio frequency characteristics

**RF range:** 195 to 270 MHz.

**RF accuracy:** main dial:  $\pm 0.5\%$ ; electronic vernier:  $\pm (10\% + 1 \text{ kHz})$  after one-hour warm-up.

**RF stability:**  $< 0.02\%$  per hour, after two-hour warm-up.

**RF output:** range:  $0.1 \mu\text{V}$  to  $0.2 \text{ V}$  (across external 50-ohm load at panel jack); accuracy:  $\pm 10\%$ ,  $0.1 \mu\text{V}$  to  $50 \text{ k} \mu\text{V}$ ;  $\pm 20\%$ ,  $50 \text{ k} \mu\text{V}$  to  $0.2 \text{ V}$ ; auto level set: holds rf monitor meter to "red line" over band; impedance: 50 ohms; vswr:  $< 1.2$ ; spurious output: all spurious rf output voltages are at least 25 dB below desired fundamental.

**RF leakage:** sufficiently low to permit measurements at  $0.1 \mu\text{V}$ .

#### Amplitude modulation characteristics

**AM range:** internal, 0 to 50%; external, 0 to 100%.

**AM accuracy:**  $\pm 10\%$  of reading at 400 Hz at 30% and 50%.

**AM calibration:** 30, 50, 100%.

**AM distortion:**  $< 5\%$  at 30%,  $< 8\%$  at 50%,  $< 20\%$  at 90%.

**AM fidelity:**  $\pm 1 \text{ dB}$ , 30 Hz to 200 kHz.

**External AM requirements:** approximately 50 volts rms into 7500 ohms for 100% AM.

#### Frequency modulation characteristics

**FM deviation range:** internal, 0 to 300 kHz in 4 ranges; external, 0 to 300 kHz in 4 ranges.

**FM deviation accuracy:**  $\pm 5\%$  of full scale (indication proportional to p-p modulating waveform at 400 Hz).

**FM calibration:** 0 to 15 kHz in increments of 0.5 kHz, 0 to 30 kHz in increments of 1 kHz, 0 to 150 kHz in increments of 5 kHz, 0 to 300 kHz in increments of 10 kHz.

**FM non-linearity:**  $< 1.5\%$  at 150 kHz,  $< 5\%$  at 300 kHz; ("least squares" departure from straight line passing through origin.)

**FM fidelity:**  $\pm 1 \text{ dB}$ , 5 Hz to 500 kHz;  $\pm 3 \text{ dB}$ , 3 Hz to 1 MHz.

**Spurious FM:** total rms spurious FM from 60 Hz power source is at least 60 dB below 150 kHz ( $< 150 \text{ Hz}$ ).

**External FM requirements:**  $< 1$  volt rms into 100 k ohms in parallel with less than 50 pF for 150 kHz deviation.

**Pulse modulation characteristics:** PM source: external.

**PM rise time:**  $< 0.25 \mu\text{sec}$ .

**PM fall time:**  $< 0.8 \mu\text{sec}$ .

#### Modulation oscillator characteristics

**OSC frequency:** 50 Hz, 400 Hz, 1700 Hz, 3900 Hz, 10.5 kHz, 30 kHz, 70 kHz, 100 kHz.

**OSC accuracy:**  $\pm 5\%$ .

**OSC distortion:**  $< 0.5\%$ .

**Accessory furnished:** 00502B Patching Cable.

#### Physical characteristics

**Dimensions:**  $16\frac{3}{4}$ " wide,  $10\frac{1}{4}$ " high,  $18\frac{3}{8}$ " deep (425 x 260 x 467 mm).

**Weight:** net 45 lbs (20.3 kg); shipping 60 lbs (27 kg).

**Power:** 105 to 125 or 210 to 250 V, 50 to 400 Hz, 100 W.

**Price:** HP 202J, \$1595.

## UNIVERTER

0.1 to 55 MHz for 202H, J Signal Generators  
Model 207H



## SIGNAL SOURCES

The HP 207H Univerter, a frequency converter with unity gain, is designed for use with HP 202H FM-AM Signal Generator (page 353) and the 202J Telemetering Signal Generator (page 354) to provide additional frequency coverage from 100 kHz to 55 MHz, including commonly used intermediate frequencies.

The univerter consists essentially of a semi-fixed frequency, 200 MHz heterodyne oscillator, a wideband amplifier and a self-contained regulated power supply. In operation, the internal heterodyne oscillator beats with the output signal of the 202H (199.9 to 145 MHz) or 202J (200.1 to 255 MHz), and the difference frequency is passed through the wideband amplifier to the output system.

The output frequency of the univerter is easily determined by subtracting 200 MHz from the frequency dial reading of the 202J or subtracting the 202H frequency dial reading from 200 MHz. In addition, a front-panel incre-

mental frequency control, calibrated in 5 kHz increments provides continuous control over a  $\pm 300$  kHz range. External adjustments are provided for setting the overall gain of the instrument to unity and for adjusting the center frequency of the local oscillator to zero beat with the 200 MHz dial calibration of the 202H or 202J.

To use the univerter, it is only necessary to connect the rf output of the associated 202H or 202J Signal Generator to the input of the univerter; three separate outputs are provided. The X1 output provides unity gain, under the control of the signal generator attenuator, and is suited for most general-purpose applications. The X0.01 output attenuates the input signal level, as well as the random noise power output, 40 dB, and is specifically provided for receiver measurements in the low microvolt region. An uncalibrated, high-level output provides a minimum of one volt into a 300-ohm load, with 0.1 volt input.



### Specifications

(when used with 202H and 202J Signal Generators)

#### Radio frequency characteristics

**RF range:** 100 kHz to 55 MHz (with 199.9 to 145 MHz input from 202H, with 200.1 to 255 MHz input from 202J).

**RF calibration:** incremental range,  $\pm 300$  kHz; incremental calibration, increments of 5 kHz; incremental accuracy,  $\pm (3\% \pm 1 \text{ kHz})$ .

**RF stability:** short-term,  $< 0.001\%$  (5 minutes); long term,  $< 0.005\%$  (1 hour); line voltage  $< 400$  Hz/V.

#### RF output

**Range:** (A)  $1 \mu\text{V}$  to  $0.1 \text{ V}^*$  (X1); (B)  $0.01 \mu\text{V}$  to  $1 \text{ mV}^*$  (X0.01); (C)  $> 1 \text{ V}^{**}$ , high output.

**Accuracy:** (A) reproduces output of 202H or 202J  $\pm 1$  dB; (B) reproduces output of 202H or 202J  $\pm 2$  dB

**Impedance:** (A) 50 ohms nominal; (B) 50 ohms nominal; (C) 300 ohms nominal.

**Spurious output:** all spurious output voltages are better than 25 dB below desired output; spurious output of 207H alone consists of random noise and 200 MHz local oscillator; at X0.01 output, noise power essentially equivalent to 50-ohm resistor at room temperature.

#### Modulation characteristics

**Range:** duplicates FM and AM modulation of 202H or 202J.

**Distortion:** FM, no appreciable distortion; AM, no appreciable distortion for input levels  $< 0.05 \text{ V}$ .

**Accessories furnished:** 00524A Patching Cable; high-output plug.

**Accessories available:** 00501B Output Cable, \$15.50; 00502B Patching Cable, \$6.50; 00506B Patching Cable, \$6.50; 00514B Output Cable, \$15.50

#### Physical characteristics

**Mounting:** cabinet for bench use; readily adaptable for 19" rack mounting.

**Finish:** gray panel; blue cabinet (other finishes available on special order).

**Dimensions:**  $16\frac{3}{4}$ " wide,  $5\text{-}33/64$ " high,  $18\frac{3}{8}$ " deep (425 x 140 x 467 mm).

**Weight:** net 18 lbs (8.1 kg); shipping 30 lbs (13.5 kg).

**Power:** 105 to 125 V or 210 to 250 V, 50 to 1000 Hz, 50 W.

**Price:** 207H, \$595.

\*after one-hour warm-up.  
\*\*across external 50-ohm load at panel jack.  
\*with 0.1 V input and 300-ohm output load.  
\*for input levels  $< 0.05$  volts.

## SIGNAL SOURCES



## DME/ATC TEST SET

Testing, calibrating DME & ATC transponder equipment  
Model 8925A

The HP 8925A DME/ATC Test Set is specifically designed for the testing and calibration of DME (Distance Measuring Equipment) and ATC (Air Traffic Control) transponder aircraft equipment. The test set is completely self-contained (except for video modulators) and consists of a continuously tuneable signal generator, direct-reading frequency counter, solid-state modulator, frequency meter, peak power measuring system and all necessary circuitry for interconnection to the radio set under test.

The basic test signal is generated by a Hewlett-Packard H01-8614A Signal Generator, which covers the range 962 to 1213 MHz. The test frequency is indicated approximately on the front-panel dial of the signal generator and is simultaneously monitored and indicated on a solid-state HP 5245L Electronic Counter, employing a 5254A Frequency Converter. Frequency may be set to within 50 kHz with the  $\Delta f$  control on the H01-8614A. The rf output of the signal generator is automatically leveled, eliminating the need to adjust the output level as frequency is varied, and the output attenuator is calibrated to read out directly the applied signal level to the radio under test over the range from  $-10$  to  $-100$  dBm.

The CW output of the signal generator is modulated by a Hewlett-Packard H01-8403A Modulator employing PIN diodes as modulator elements. Pulsed video test signals simulating DME/ATC ground emission are fed to the modulator from either an external Collins Radio 578D-1 DME Bench Test Set modified for Gaussian pulse output or 578X-1 ATC Transponder Test Set. The modulator also incorporates complete provisions for side-lobe suppression measurements, in that the second pulse of a train of two or three pulses may be varied over the range  $+1$  to  $-10$  dB from the first pulse with a calibrated front-panel control. TACAN bearing information also may be simulated, employing an external audio frequency source.

The modulated rf output is fed into an HP 13505A Isolator-Monitor, which performs three separate functions. Isolation is provided for the high-power transmitter output of the radio set under test by a microwave circulator, protecting the signal generator and modulator. Auxiliary calibrated rf outputs are provided for operation of the frequency meter and peak power measuring system. A diode and a linear heterodyne monitor are provided for viewing the pulsed rf test signals on an external oscilloscope such as the HP 180A (pages 454, 455). Switching from the normal operating mode to the monitoring mode is simply accomplished by operating a front-panel control which activates an internal electrically-operated coaxial switch. A transmitter interlock is provided via rear terminals for de-energizing the DME/ATC transmitter when the test set load is removed from the antenna of the radio set under test.

An HP 8905A Wavemeter provides direct measurement to  $\pm 0.5$  MHz of the ATC reply frequency over the range from 1070 to 1110 MHz. Response of the self-powered transmission-type wavemeter is directly indicated on a front-panel meter.

An HP 8900B Peak Power Calibrator provides complete facilities for measuring the peak power output of DME and ATC transmitters over the range from 10 to 2000 watts. In operation, an external oscilloscope is connected to the video output, the front-panel controls are adjusted by observing the oscilloscope display, and the peak power is read directly on the panel meter. The calibrator also incorporates a wideband detector for viewing transmitter waveforms on an external oscilloscope. This output also provides a reply signal for DME distance measurements. The individual modules are mounted in an enclosed rack cabinet which includes a master power distribution system and forced air cooling. All necessary interconnecting cables are included.

### Specifications

#### Radio frequency characteristics

**RF range:** 962 to 1213 MHz.

**RF accuracy:** determined by ability to set to desired reading on counter.

**RF settability:** better than 100 kHz.

**RF stability:** temperature, approx. 0.005% per degree C; line voltage,  $< 0.003\%$  ( $\pm 10\%$  line voltage change).

#### RF output

**Range:**  $-10$  to  $-100$  dBm across external 50-ohm load at output jack.

**Accuracy:**

Attenuator setting	ATC (1015 to 1045 MHz)	DME (962 to 1213 MHz)
$-10$ to $-17$ dBm	$+0.7$ to $1.2$ dB	$+1.1$ to $1.6$ dB
$-17$ dBm	$\approx 0.6$ dB	$\approx 1$ dB
$-17$ to $-100$ dBm	$\approx (0.8 + 0.06$ per 10 dB) dB	$\approx (1.2 + 0.06$ per 10 dB) dB

**Leveled output:** (fixed atten. position) ATC,  $\pm 0.2$  dB; DME,  $\pm 0.6$  dB.

**Impedance:** 50 ohms.

**VSWR:**  $< 1.35:1$ .

#### Pulse modulation characteristics

**PM source:** simulation of DME/ATC ground emission as provided by Collins 578X-1 and 578D-1 (modified for Gaussian pulse) Test Sets.

**PM rise time:** ATC,  $> 50$  nsec and  $< 100$  nsec; DME, controlled by pulse source to meet "Pulse Shape" Spec., Sect. G, Appendix A, RTCA 167-59/DO-99.

**PM fall time:** ATC,  $> 50$  nsec and  $< 200$  nsec; DME, controlled by pulse source to meet "Pulse Shape" Spec., Sect. G, Appendix A, RTCA 167-59/DO-99.

**PM overshoot:** ATC,  $< 5\%$ ; DME, not meaningful.

**Side-lobe suppression:** the second pulse of a train of 2 (or 3) pulses may be varied  $+1$  to  $-10$  dB from the first pulse when its leading edge is  $\geq 2$   $\mu$ sec from the first pulse leading edge; (see RTCA 181-61/DO-112, Appendix A, T-6, Steps 1, 2, 3, 4, 9, 10); calibrated SLS control accurate to  $\pm 0.5$  dB.

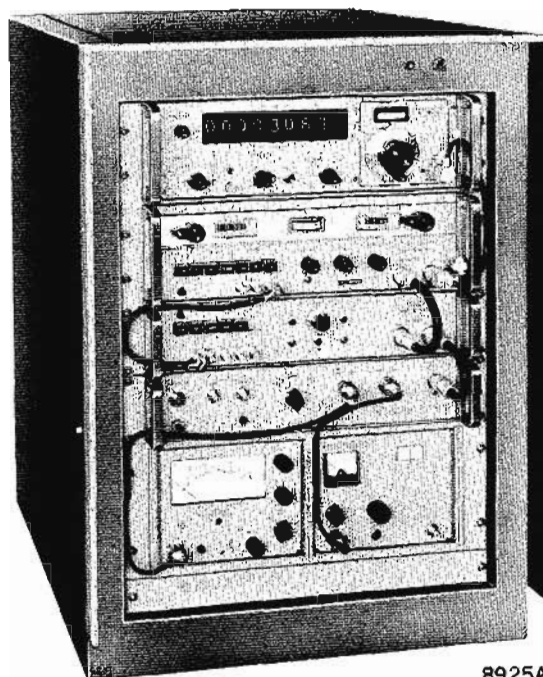

8925A

**Simulated bearing input:** audio frequency input to BNC jack under TACAN button will simulate bearing modulation to a depth of 55% max. (3.8 dB above pulse tips).

#### Power measurement characteristics

**RF range:** 962 to 1213 MHz.

**RF power range:** 100 to 2000 watts peak (ARINC units); 10 to 200/100 to 2000 watts peak (Gen. Aviation & ARINC units) available as factory modification with accessory attenuator.

**RF power accuracy:**  $\pm 1.2$  dB ( $\pm 0.6$  dB from calibration curve).

#### Frequency measurement characteristics

**RF range:** 1070 to 1110 MHz.

**RF accuracy:**  $\pm 0.5$  MHz; direct meter indication for peak power 250 to 1000 watts at 25°C; video output for external scope indication for input peak power down to approx. 10 watts.

#### Monitor characteristics

**Signal generator monitor (Monitor-Sig Gen), heterodyne monitor (Het Mon):**

Frequency range: 1018 to 1032 MHz (for beating oscillator  $1025 \pm 1$  MHz).

Output level: 0.5 volts peak minimum at  $-10$  dBm rf level (at IF center frequency).

Load impedance: 150 ohms nominal.

Bandwidth: 9 MHz nominal (equivalent low-pass bandwidth 4 MHz).

Linearity:  $\pm 0.5$  dB ( $-10$  to  $-20$  dBm rf level).

#### Diode monitor (Diode Mon):

Frequency range: 962 to 1213 MHz.

Output level: 0.1 V peak min. at  $-10$  dBm rf level.

Low-pass bandwidth: 5 MHz nominal.

#### Transmitter Monitor (Monitor-Xmtr)

Output level: approx. 0.2 V peak for 200 watts peak input (100 to 2000 watts peak power range); 20 watts peak input (10 to 200 watts peak power range).

Load impedance: 150 ohms nominal.

Bandwidth: 10 MHz nominal.

Linearity:  $\pm 1$  dB for 200 to 2000/20 to 200 watts peak input.

Transmitter interlock: terminals are provided for de-energizing the transmitter when the system internal load is removed from the transmitter antenna.

**Instrument complement:** HP H01-8614A Signal Generator, HP H01-8403A Modulator, HP 5245L Electronic Counter, HP 5254B Frequency Converter, HP 13505A Isolator-Monitor, HP 8900B Peak Power Calibrator, HP 8905A Wavemeter.

**Accessories available:** HP 180A Oscilloscope.

#### Physical characteristics

**Mounting:** enclosed rack mounting complete with forced-air cooling.

**Finish:** gray (other finishes available on special order).

**Dimensions:** 23" wide,  $32\frac{1}{4}$ " high, 26" deep (584 x 819 x 660 mm).

**Weight:** net 285 lbs (129.3 kg); shipping 335 lbs (150.8 kg).

**Power:** 105 to 125 or 210 to 250 volts, 50 to 60 Hz, 400 watts: a master circuit breaker/switch controls power to the complete rack.

**Price:** HP 8925A, \$12,090.

**Options (specify by option number):**

01 Less 5245L/5254A Counter, \$8315.

02 Less cabinet, \$11,500.

03 Dual power range (10 to 200/100 to 2000 watts), add \$100.



## SIGNAL GENERATORS

Test and Calibrate aircraft VOR and ILS  
Models 211A, 232A

### 211A Signal Generator

The HP 211A Crystal-Monitored Signal Generator is specifically designed for the testing and calibrating of aircraft VOR and ILS localizer radio receiving equipment operating within the frequency range from 88 to 140 MHz. It also may be used for laboratory and development work where a precision-type amplitude-modulated rf signal source is required.

### 232A Signal Generator

The FAA Instrument Landing System for aircraft includes a glide slope receiver for indicating the proper rate of descent. The HP 232A Glide Slope Signal Generator was designed for use in testing and calibrating these glide slope receivers.

#### Specifications, 211A

##### Radio frequency characteristics

**RF range:** master oscillator: 88 to 140 MHz in one range; crystal oscillator: 110.1 and 114.9 MHz.

**RF output:** range: 0.1  $\mu$ V to 0.2 volt (across external 50-ohm load); impedance: 50 ohms; spurious output: all spurious rf output voltages are better than 40 dB below desired output.

**Amplitude modulation characteristics:** AM range, 0 to 100% in two ranges.

##### Physical characteristics

**Dimensions:** 211A and 211AP1 (Power Supply): 19 $\frac{1}{2}$ " wide, 10 $\frac{1}{2}$ " high, 9 $\frac{1}{2}$ " deep (495 x 267 x 241 mm).

**Weight:** net 63 lbs (28,4 kg); shipping 86 lbs (38,7 kg).

**Power:** 105 to 125 volts, 50 to 60 Hz, 150 watts.

**Price:** HP 211A, 211AP1, \$2190.

#### Specifications, 232A

##### Radio frequency characteristics

**RF range:** (A) 329.3 to 335 MHz in increments of 0.3 MHz; (B) 20.7 MHz; other frequencies between 15 and 30 MHz available on special order.

**RF accuracy:**  $\pm 0.0065\%$  (crystal controlled).

**RF output:** range: 1  $\mu$ V to 0.2 V (across external 50-ohm load); accuracy:  $\pm 10\%$  approximately; impedance: 50 ohms.

**RF leakage:** sufficiently low to permit measurement at 1  $\mu$ V.

##### Amplitude modulation characteristics

**Am range:** internal: 0 to 100% in two ranges; external: 0 to 100% in two ranges.

**AM calibration:** increments of 2%, 0 to 50%; increments of 10%, 0 to 100%.

**Demodulated output:** available at front-panel posts through 2  $\mu$ F capacitor.

##### Modulating oscillator characteristics

**OSC frequency:** (A) 1000 Hz; (B) 90 to 150 Hz in the following tone ratios: 0 dB,  $\pm 0.5$  dB,  $\pm 1$  dB,  $\pm 2$  dB,  $\pm 3.3$  dB,  $\pm$  infinite dB (calibrate).

##### Physical characteristics

**Dimensions:** 20 $\frac{7}{8}$ " wide, 10 $\frac{1}{2}$ " high, 12" deep (511 x 267 x 305 mm).

**Weight:** net 64 lbs (28,8 kg); shipping 75 lbs (33,8 kg).

**Power:** 105 to 125 volts, 60  $\pm 1$  Hz, 150 watts.

**Price:** HP 232A, \$2375.

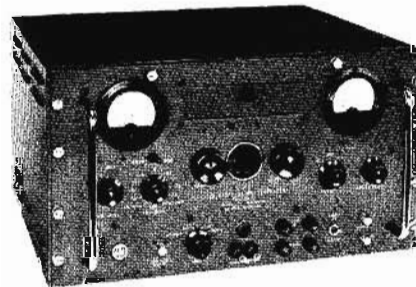

232A

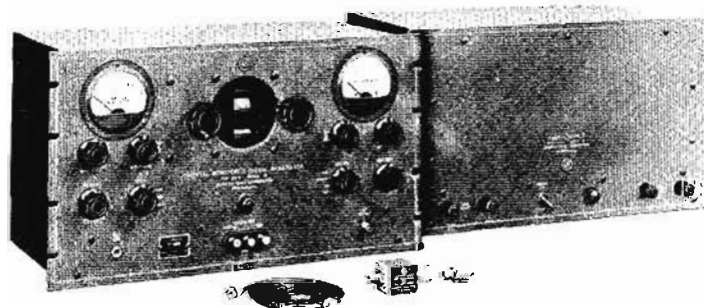

211A

## RF SWEEPER WITH OCTAVE-BAND PLUG-INS



## SIGNAL SOURCES

### Wideband RF and microwave sweepers

Swept-frequency measurement techniques first became feasible when dependable means of sweeping the RF sources were developed. The original mechanically swept sources (usually klystrons) later gave way to electronically tuned backward-wave oscillators which brought added sophistication to swept measurements. Hewlett-Packard's extensive use of swept-frequency testing has not only resulted in major improvements in measurement techniques, but also has provided the experience that has led to development of the HP 8690 Series Sweep Oscillators.

These instruments cover the frequency range 100 kHz to 110 MHz and 1 to 40 GHz. They provide calibrated broad and narrow sweeps, and markers which amplitude-modulate the RF may be used on either. The markers also may be used as end points of a second broadband sweep. Manual sweep reduces X-Y recorder set-up time, and push-buttons greatly simplify operation. The RF output frequency may be swept slowly enough for presentation on an X-Y recorder or fast enough for no-flicker presentation on an oscilloscope.

The 8690 Series sweep oscillators have been designed to incorporate plug-in RF units enabling the operator to change frequency bands quickly. This eliminates the need for duplicate equipment to cover each RF or microwave band. The 8690A Main-frame provides two independent broad-band sweeps, start-stop, marker sweep, and one precision narrow band sweep, a calibrator  $\Delta f$  sweep. Included is internal square-wave modulation with a range of 950 to 1,050 Hz plus external AM and FM. External FM permits frequency-programming, including externally controlled sweeps over the whole range or any part of it.

The HP 8698A low-frequency RF unit covering 100 kHz to 110 MHz contains a transistorized frequency comparator-type voltage-tuned oscillator covering a three-decade frequency range. This instrument is a swept signal generator containing an output attenuator and offering leveled power output across its entire

frequency range. Calibrated power output (+10 dBm to -110 dBm), very low residual FM and excellent frequency accuracy and setability place the 8690A in the signal-generator performance class; it will fill a number of signal generator applications when used on a CW basis. The 8698A RF Unit extends the calibrated sweep capability previously associated only with microwave sweepers into the RF range. Its excellent frequency accuracy and linearity provide calibrated sweep displays, eliminating the need for markers to determine frequency at either intermediate or end points in the sweep display.

Models 8691A/B-8697A RF Units contain voltage tuned backward wave tubes covering the frequency range 1 to 40 GHz. RF units in the 1 to 12.4 GHz range can be provided with PIN diode attenuators which permit all of the amplitude modulation functions, including leveling, to be performed independently of the backward-wave tube. The result is virtual elimination of frequency pulling, which, in turn, results in extremely high frequency accuracy and linearity and very low incidental FM.

For applications requiring sweeper operation in several frequency bands, the Model 8706A RF Control Unit may be inserted in the 8690A Sweep Oscillator Mainframe to program up to three 8707A RF unit Holders, containing three RF units each. Any one of nine RF units may then be swept on a preselected basis at the touch of a button on the 8706A control panel or by remote contact closure.

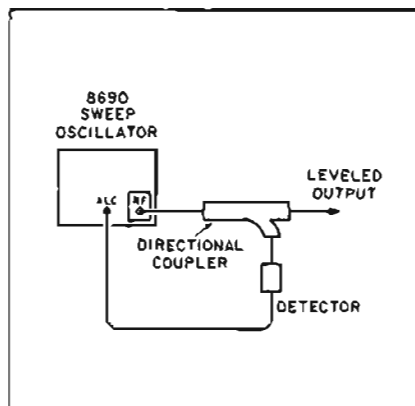

Figure 1. Basic closed-loop leveling system.

### Leveled output from sweep oscillators

The development of closed-loop feedback systems for leveling sweep oscillator output power has greatly expanded the practical scope of swept-frequency measurements. The basic closed-loop system is shown in Figure 1.

The HP 8690 Series Sweep Oscillators contain a leveling amplifier for automatic level control (ALC); the power variation that occurs at the system output is primarily determined by coupler and detector variation. Leveling can be accomplished with either a crystal detector or thermistor mount/power meter as the detector. For coaxial systems, Hewlett-Packard has developed the 780 Series Directional Detectors (page 274) which consist of a high directivity, flat directional coupler combined with a high sensitivity, flat-response crystal detector. System flatness of better than  $\pm 0.3$  dB over octave bandwidths is typical, using Hewlett-Packard directional detectors. For power meter leveling in coax, HP 790 Series Flat Directional Couplers (page 274) can be used in conjunction with the HP 478A Coax Thermistor Mount and 431C Power Meter (page 378). Power meter leveling allows setting of known absolute power levels, and the 431C's range switch can serve as a very accurate attenuation control.

To level output power in waveguide systems, HP 752 Series Waveguide Directional Couplers (page 276) and 424A Series Waveguide Crystal Detectors (page 273) are used. With better than 40 dB directivity, 752 Series Couplers in leveled systems provided good equivalent source match — nominally 1.02 swr. Waveguide couplers will typically ex-

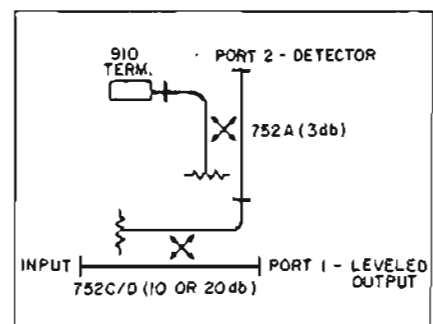

Figure 2. "Back-to-back" waveguide coupler arrangement for extremely flat output.



hibit  $\pm 0.5$  dB coupling variation over the band. In conventional reflection or transmission measurement systems employing two couplers, this variation of coupling with frequency is of little consequence because both couplers demonstrate the same coupling characteristics; hence, the variations with frequency effectively cancel. Where a greater degree of leveling is needed in waveguide, a pair of 752 couplers are connected "back-to-back" as in Figure 2. In this configuration the insertion loss of the 3 dB coupler (752A) follows a curve directly opposite to the coupling curve of the mainline 752C or D coupler. The resulting power relationship between port 1 and port 2 is flat to better than  $\pm 0.2$  dB over full waveguide bands.

### Swept frequency systems

#### Reflectometer systems

Probably the major usage of sweep oscillators is in reflectometer systems for broadband measurement of reflection and transmission characteristics. Leveling the signal source brings new latitude of readout to the user, for measurement results can be read directly rather than on a ratio basis. Sophisticated instrumentation systems employing the principles of reflectometry such as the new HP 8410A Phase-gain Parameter Measurement system described on page 244, rely upon the 8690A Series Swept Oscillators for frequency accuracy and operational simplicity.

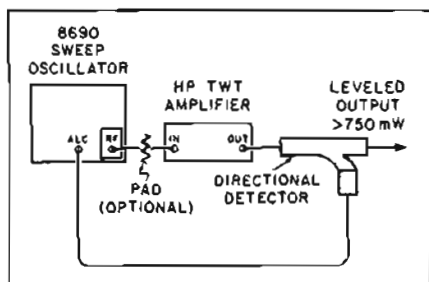

Figure 3. The E15-8690A system generates high-level (750 mW), flat output power. The pad between the sweep oscillator and the TWT amplifier is used to keep the signal level into the amplifier below that which would saturate the TWT.

#### Higher power systems

Typical backward-wave oscillators supply leveled power outputs in the

milliwatt region. Applications such as RFI-susceptibility tests and high attenuation swept measurements often require 750 mW outputs. The E15-8690 system shown in the block diagram in Figure 3 will provide better than 750 mW from 1 to 12.4 GHz.

#### Special calibration systems

Leveled systems have also been designed to level on the net forward power applied to a device, permitting the examination, for example, of the efficiency and calibration factor of coaxial and waveguide devices. The E31-8690 Power Calibration System series which employs this principle is described on page 380.

#### Swept frequency display devices

Especially useful is the new HP 1416A plug-in for the 140A and 141A Oscilloscopes (page 426). Designed expressly for use in leveled reflectometer systems using square-law detectors, the 1416A provides an accurate 30 dB of dynamic range when used with HP 423A and 424A Series Crystal Detectors. It also provides excellent resolution; sensitivity of .5 dB/cm permits close examination of results. The 1416A is particularly effective with the 141A variable persistence oscilloscope as a readout device for the swept slotted line measurement system described on page 255.

#### Swept stabilized systems

Applications such as Microwave Spectroscopy and high-Q swept-frequency cavity measurements have brought about the need for phase-locked fixed- or swept-frequency operation of the 8690 Series Sweep Oscillators. The K02- and K03-8690 Sweep Oscillator Stabilization Systems have been developed to fulfill this need.

Application Note 65 covering the use and accuracy of Swept Frequency Techniques for attenuation, impedance, power, and frequency calibration measurement provides an up-to-date compendium of the latest developments in Microwave swept measurements. This Note may be obtained from any Hewlett-Packard field office at no charge.

#### Economical, low frequency sweeper

The HP 3211A, with its Marker Plug-in unit and choice of six frequency plug-in units, is a low-cost, versatile, high-performance sweep oscillator ideally suited for use in the design, calibration, and alignment of FM tuners and receivers, and the general testing of IF sections of TV receivers, radar and communication systems, and other video to VHF circuits. Its high output ( $>.7$  V rms) and accurate 59-dB attenuator make the instrument a valuable tool for the testing of both high and low-gain circuits under variable signal conditions.

The 100 kHz to 110 MHz frequency range of the 3211A is covered by five RF plug-in units with overlapping octave ranges, operating at the fundamental frequency, and a video range heterodyne plug-in unit. These plug-in units are designed for quick and easy changing.

The Marker Plug-in unit accepts up to eight different, crystal-controlled marker oscillator plug-in boards. These internal markers may be individually turned on or off by means of front panel switches, making identification easy on the oscilloscope display. The test signal display may be set up to provide positive or negative vertical markers, or intensity modulated markers. Intensity modulated (Z-axis) markers provide well-defined frequency identification, without distorting the display waveshape. The Marker Plug-in unit also has provision for connection of additional external markers from a CW or marker generator source.

A birdie by-pass marker system transforms the markers into video pulses and applies these pulses to the detected response of the test circuit, eliminating marker distortion, and preventing the response of the test circuit from being affected by the marker system. Front panel controls are provided for the adjustment of marker sensitivity and bandwidth.

Sweep width of the 3211A is continuously adjustable to 100% of all plug-in unit ranges. The sweep rate is continuously adjustable over the range of 10 to 100 Hz, with provisions for a single, variable, 1 to 10-second sweep compatible with X-Y recording requirements.



## SWEEP OSCILLATOR

Low-cost, solid-state, plug-in versatility  
Model 3211A



## SIGNAL SOURCES



### Advantages:

- RF and marker plug-ins
- Individual on-off marker switches
- Continuous or single sweep with variable rate
- Continuous sweep width adjustment
- Width and level controls to optimize marker display

The HP 3211A Sweep Oscillator, with its 3221A Marker Plug-in unit and choice of six frequency plug-in units, is a low-cost, versatile, high-performance sweep oscillator ideally suited for use in the design, calibration, and alignment of FM tuners and receivers, and the general testing of IF sections of TV receivers, radar and communication systems, and other video to VHF circuits. Its high output ( $>.7$  V rms) and accurate 59-dB attenuator make the instrument a valuable tool for the testing of both high and low-gain circuits under variable signal conditions.

### Specifications

(With Plug-in Units Installed)

**RF range:** 100 kHz to 110 MHz, with six plug-in units

#### RF plug-in units available

RF Range	HP Model
100 kHz to 30 MHz	3212A
8 to 16 MHz	3213A
12 to 28 MHz	3214A
20 to 45 MHz	3215A
30 to 70 MHz	3216A
50 to 110 MHz	3217A

#### RF output:

**Level:**  $>.7$  V rms into 50-ohm load,  $>1.4$  V rms open circuit.  
**Flatness:**  $\pm 0.5$  dB across 50-ohm load over specified range of each plug-in unit.

**Impedance:** 50-ohms, 1.2 to 1 VSWR.

**Attenuation:** 0 to 59 dB in 1 and 10-dB steps. Electrical vernier provides level adjust between 1-dB steps.

**Attenuator accuracy:**  $\pm .25$  dB for 1-dB steps,  $\pm .5$  dB for 10-dB steps, non-cumulative.

**Spurious output:** 30 dB below output level, except for 3212A plug-in unit which is 25 dB below output level.

**Residual FM:**  $< \pm .005\%$  of center frequency except for 3212A plug-in unit which is  $< \pm 5$  kHz.

#### Sweep characteristics:

**Width:** continuously adjustable to 100% of plug-in unit range.

**Linearity:**  $\pm 1\%$  over any 25% segment of plug-in unit range,  $\pm 3\%$  over any 50% segment of plug-in unit range,  $\pm 5\%$  over any 75% segment of plug-in unit range,  $\pm 10\%$  over full range of any plug-in unit; except for 3212A plug-in unit which has a linearity of 1.2 to 1.

**Rate:** variable; repetitive sweep 10 to 100 Hz; single sweep 1 to 10 sec. Line lock provided.

**Blanking:** switch selects RF blanking or unblanking during retrace; marker blanking on retrace at all times.

#### Vertical channel:

**Detector:** internal 50 ohms or external maximum input  $< 2$  V rms.

**Output:** 4 V for 1 V input.

#### Horizontal channel:

**Output:** 0 to 15 V peak-to-peak triangular.

#### Marker characteristics:

**Internal:** HP 3221A marker plug-in unit accepts up to 8 Model 13511A crystal-controlled marker oscillators. Specify crystal frequencies desired.

**Type:** birdie by-pass; beat note detected and used to generate high-level marker pulse.

**Accuracy:** .005% for 13511A markers.

**External:** front panel BNC input to HP 3221A accepts marker input from CW source or marker generator; input requirements .25 to .5 V rms into 50 ohms.

**Display:** front panel control and switch permit addition of marker pulse to either the vertical channel output or Z axis modulation of scope with 0 to  $\pm 20$  V pulse.

**Dimensions:** 16 $\frac{3}{4}$ " wide, 5 $\frac{1}{2}$ " high, 18 $\frac{3}{8}$ " deep (426 x 140 x 552 mm).

**Weight:** net 30 lbs (13.5 kg), shipping: 40 lbs (18.2 kg).

**Power:** 105 to 125 V or 210 to 250 V, 50 to 1000 Hz, 20 W.

#### Price:

HP Model	Description	Price
3211A	Sweep Oscillator	\$750 #
3212A	RF Plug-in	\$225
3213A-3217A	RF Plug-ins	\$150 ea.
13511A	Marker Osc. Boards	\$ 40 ea.



## SWEEP OSCILLATOR

Superior performance, operation and versatility  
Series 8690

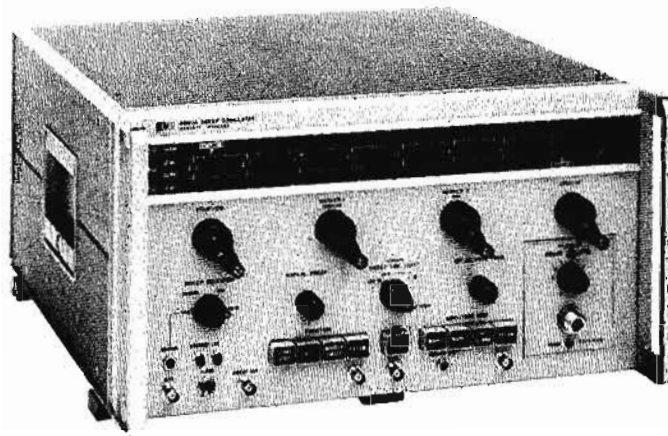

### Interchangeable RF and Control Units

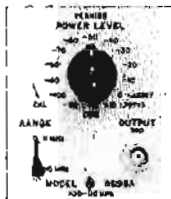

8698A

LOW FREQUENCY

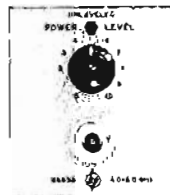

8691- 4A/B

COAXIAL BANDS

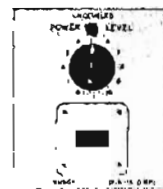

8695-7A

WAVEGUIDE BANDS



8706A

CONTROL UNIT

#### Model 8698A: 100 kHz to 110 MHz

This RF Unit is a low-frequency swept signal generator that brings 8690A microwave sweeper sophistication, precision and operating features into the RF region. The unit features a calibrated 1% accuracy frequency display, 0.5% linearity, and 100 mW leveled output, calibrated from +10 dBm to -110 dBm. Minimum residual FM and excellent stability enable low frequency CW signal generator applications to be accurately satisfied. The highly accurate calibrated display establishes measurement confidence. Crystal calibrator marker pips are not required. One narrowband and two broadband continuously adjustable and calibrated sweeps with automatic, triggered or manual control are available. The unit offers complete modulation capabilities including internal square wave, and external AM and FM. See page 366.

#### Model 8691-4A/B: 1 to 12.4 GHz

Coaxial microwave frequencies from 1 to 12.4 GHz are covered by the 8691-4A/B RF Units. "B" models are PIN diode-attenuator modulated and maintain excellent frequency accuracy and stability to satisfy the most stringent amplitude modulation requirements. The "A" models contain grid modulated BWO's. PIN diode-attenuator modulation eliminates frequency pulling during AM, which results in extremely high frequency accuracy, linearity and very low residual FM. Option 01 internal leveling is available on all RF units covering 1 to 12.4 GHz except the 8691B and the 8692B. Models are avail-

able on special order to cover every frequency range for which there is a BWO. See page 363.

#### Models 8695-7A: 12.4 to 40 GHz

The P, K, and R waveguide bands are covered by the Models 8694A, 8696A and 8697A respectively. The units contain grid modulated BWO's and have a frequency range and linearity of  $\pm 1\%$  over a 6 dB power range. Output power variation with external leveling is  $\pm 0.2$  dB. See page 363.

#### Model 8706A Control Unit

The 8706A Control Unit, with the Model 8707A RF Unit Holder allows microwave and RF wideband testing to be performed without interchanging RF Units. The 8706A Control Unit immediately switches between RF Units contained in up to three Model 8707A RF Unit Holders. Each RF Unit Holder is the same size as the 8690A Sweep Oscillator and accepts three RF Units. Thus, up to nine RF Units can be selected by simply pressing a button. Switching time is less than 1 second and no adjustments are required. A normalized scale, reading from 0 to 100 is used for all RF Unit frequency ranges. The complete microwave spectrum from 1 to 40 GHz plus the RF band of 100 kHz to 110 MHz is at your fingertips. Preset start and stop sweep frequencies for each RF unit can be set on the front panel of the Model 8707A RF Unit Holder. This creates a preset mode of operation in which the 8690A Sweep Oscillator can provide a third broad or narrowband sweep.

Price: HP 8706A Control Unit, \$225. HP 8707A RF Unit Holder, \$700.

### Flexibility and economy

IT'S A SNAP—The snap-in scale that accompanies each RF unit illustrates the ease of obtaining wide frequency coverage. RF units that preserve integral sweeper performance can be changed in seconds without adjustment. The RF units are easily secured in place from the rear with a single locking handle. A wide selection of RF units, including special models to cover every frequency range for which there is a BWO, assures you of the most flexible RF-microwave sweep oscillator at the lowest possible cost.

### Series 8690 sweep oscillators

The Hewlett-Packard 8690A Sweep Oscillator and 8690A/B Series RF Units offer you all the advantages of single unit sweep oscillators plus economical multiband capability. The 8698A RF Unit sweeps the range of 100 kHz to 110 MHz with outstanding frequency accuracy and linearity. Complete coverage from 1 to 40 GHz is available with RF units featuring a choice of PIN diode modulation ("B" models), grid modulated BWO units ("A" models), and optional internal leveling. RF units can be changed quickly and without adjustment. Snap-in scales are keyed for easy changing and accurate positioning. The full width maximum resolution scale and a human engineered layout of the front panel controls allow simple, uncomplicated operation. Ease of operation is enhanced by pushbutton function selection, lighted function indicators adjacent to the scale, presentation of all frequency information which may be read at a glance, and simplified X-Y recorder setup through the use of manual sweep control. Highly accurate, calibrated frequency displays, broad and narrowband sweeps, external FM for frequency sweep programming, CW operation, automatic triggered or manual sweep control plus leveling in all modes of operation combine to give you unequalled performance and versatility in a space saving package design. In addition, the Model 8706A Control Unit, which plugs into the sweep oscillator like an RF unit, permits immediate band switching between up to nine selected RF units contained in up to three Model 8707A RF Unit Holders (see page 367).

### RF units

Four types of RF units are available, permitting selection to meet any application requirement: the Model 8698A low frequency signal generator; the Models 8691-4A/B featuring PIN modulation or grid modulated BWO's and covering the coaxial frequencies from 1 to 12.4 GHz; and the Models 8695-7A for waveguide coverage of the P, K, and R bands.

The Model 8698A RF unit covers two frequency ranges, selected by front panel switch: 100 kHz to 11 MHz and 1 to 110 MHz. The unit features a frequency discriminator feedback circuit to obtain extremely low residual FM, excellent frequency accuracy and linearity. The Model 8691-4B RF Units, covering 1 to 12.4 GHz feature PIN diode attenuators which permit all of the amplitude modulation functions including leveling, to be performed independently of the backward wave oscillator tube (BWO). The result is a virtual elimination of frequency pulling, enabling excellent frequency accuracy and linearity, low incidental FM, permitting a wide variety of modulation conditions over a 10 dB dynamic range. The "A" type model RF Units use grid modulated BWO's for AM and leveling functions. The grid modulated BWO RF Units are available in seven models. Models 8691-4A have 50 ohm output with type N connectors; the Models 8695-7A have P, K, and R band waveguide flange outputs respectively. All Model 8692-7A/B Units have shielded BWO's and meet the RFI measurement test standards specified in MIL-I-6181D.

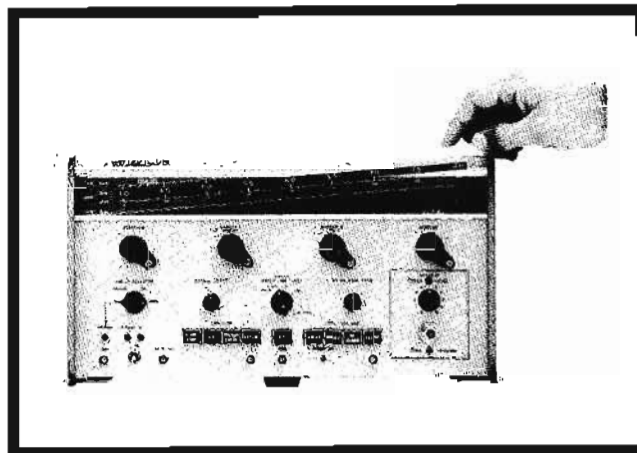

### Sweep functions and monitors

Two independent frequency markers, set separately on the "start-stop" sweep whose end points can be set anywhere in the band. Independent controls set the start and stop frequencies on the scale. Thus, the set frequency range can be swept up or down, depending only on the setting of the start frequency with respect to the stop frequency.

Two independent frequency markers, set separately on the scale and direct reading in GHz, can be positioned anywhere in the band. The markers amplitude modulate the RF output, providing triangular markers sharp enough to give high resolution on narrow sweeps, yet broad enough to be quite visible on the widest sweeps. Marker amplitude can be adjusted from the front panel. The markers can be used as end points for a second broadband sweep which starts at the Marker 1 frequency and stops at the Marker 2 frequency. The marker sweep is especially advantageous. Extensive Hewlett-Packard design experience using swept-frequency techniques has proven that valuable time can be saved by bracketing circuit discontinuities with the markers. By pressing the marker sweep button, expanded investigation of the frequency range of interest is immediately available. Thus, the two independently adjustable broadband sweeps can be set for study of either broad or narrowband frequency ranges. Besides sweeping from a start frequency to a stop frequency, the 8690 provides a continuously calibrated narrow band sweep, the  $\Delta F$  sweep, which is symmetrical about a center frequency. Calibrated directly in MHz, the  $\Delta F$  sweep width is continuously adjustable from 0 to 10% of the band. Frequency markers can be applied to the  $\Delta F$  as well as the start-stop sweep.

### Sweep modes

Automatic, triggered and manual sweeps are available, in addition to CW operation. Automatic and triggered sweep times are adjustable from 0.01 to 100 seconds, and the triggered sweeps can be synchronized from an external source or started manually from a front panel pushbutton. To enhance the clarity of oscilloscope presentations, RF power is blanked during retrace to produce a zero base line; however RF is restored before the start of the next sweep to eliminate transients during the early part of the sweep. Oscilloscope photography at slow sweeps is simplified by a front panel sweep indicator that lights automatically during the sweep. For X-Y recording, an automatic pen lift circuit is provided. The circuit drops the pen during the stabilizing period prior to the sweep and lifts the pen during the second stabilizing period which occurs at the end of the sweep just before retrace. Thus, transients and retrace lines are eliminated from X-Y plots. During manual sweep, a front panel control varies the RF frequency between the limits set on the selected sweep function. With the use of manual sweep, X-Y recorder setup time is just a few seconds.



## SWEEP OSCILLATOR CONTINUED

Superior performance, operation and versatility  
Series 8690

### Leveling

Leveling minimizes the variations in RF output amplitude with frequency. The 8690's are designed for external, closed loop leveling. This is accomplished by driving the built-in leveling amplifier with a signal derived by sampling RF output power with a directional coupler and detector or thermistor mount combination. The amplified signal is applied to the modulating circuits in the RF Unit to maintain a constant power at the output of the directional coupler. External leveling eliminates the frequency dependent transmission characteristics of any components between the oscillator and sampling point and also virtually eliminates source mismatch. Thus, leveled power can be established at any point in the system even though it is remote from the source. The degree of leveling is primarily determined by the coupler and detector variation.

Internal leveling is available as Option 01 on all grid modulated BWO RF Units below 12.4 GHz, Models 8691-4A, and on PIN diode attenuator modulated RF Units above 4 GHz, Models 8693-4B. Internally leveled RF Units are useful in less critical applications in which transmission variations between oscillator and test point are not significant or when a package free of external elements is desired.

### Modulation

All modulation functions are selected by pushbutton, and can be used simultaneously. Included is internal square wave modulation, 950 to 1050 Hz, plus external AM and FM. External FM permits frequency programming, including externally controlled sweeps over all or any part of the band.

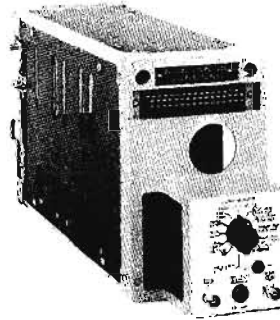

The Model K01-8690A Calibrator facilitates 8690A Sweep Oscillator calibration and troubleshooting. The unit plugs into the 8690A like an RF Unit. All circuit points sampled during the calibration procedure are presented on front-panel BNC connectors. The unit switches in standard calibrating circuits, equivalent to those in the RF Units, to ensure interchangeability of all 8690 Series RF Units in the 8690A Sweep Oscillator.

### Specifications, 8690A Sweep Oscillator (with RF Unit installed)

#### Sweep functions

**Start-stop sweep:** sweeps from "start" to "stop" frequency setting.

**Range:** both settings continuously and independently adjustable over the entire frequency range; can be set to sweep either up or down in frequency.

**End-point accuracy:** same as RF Unit frequency accuracy.

**Marker sweep:** sweeps from "Marker 1" to "Marker 2" frequency setting.

**Range:** both settings continuously and independently adjustable over the entire frequency range; can be set to sweep either up or down in frequency.

**End-point accuracy:** same as RF Unit frequency accuracy.

**$\Delta F$  sweep:** sweeps upward in frequency, centered on CW setting.

**Width:** continuously adjustable from zero to 10% of the frequency band; calibrated directly in MHz.

**Width accuracy:**  $\pm 10\%$  of  $\Delta F$  being swept  $\pm 1\%$  of maximum  $\Delta F$  ( $\pm 20\% \pm 2\%$  respectively with 8691A/B RF Units).

**Center-frequency accuracy:** same as RF Unit frequency accuracy.

**Frequency markers:** two frequency markers, independently adjustable over the entire frequency range, amplitude modulate the RF output; amplitude is adjustable from the front panel; the markers are also available for external use.

**Accuracy:** same as RF Unit frequency accuracy.

**Resolution:** better than 0.05% of RF Unit bandwidth.

**Marker output:** triangular pulse, typically -5 V peak into 1000 ohm load.

**CW operation:** single-frequency RF output selected by START/CW or MARKER 1 control, depending on sweep function selected.

**Accuracy:** same as RF Unit frequency accuracy.

**Preset frequencies:** start-stop sweep end points and marker frequencies can be used as four preset CW frequencies.

#### Sweep mode

**Auto:** sweep recurs automatically.

**Manual:** front-panel control provides continuous manual adjustment of frequency between end frequencies set in any of the above sweep functions.

**Triggered:** sweep is actuated by front-panel pushbutton or by externally applied signal  $< -25$  V peak,  $> 1$   $\mu$ sec pulse width, and  $> 0.1$  V/ $\mu$ sec rise.

**Sweep time:** continuously adjustable in four decade ranges, 0.01 to 100 seconds; can be synchronized with the power line frequency.

**Sweep Indicator:** front-panel indicator lights during the sweep provides indication of sweep duration on slower sweep times.

**Sweep output:** direct-coupled sawtooth, zero to approximately +15 V, concurrent with swept RF output; zero at start of sweep, approximately +15 V at end of sweep regardless of sweep width or direction; source impedance, 10,000 ohms.

**Frequency linearity:**\* same as RF Unit frequency accuracy.

**Blanking:** RF automatically turned off during retrace, turned on after completion of retrace; on automatic sweeps, RF is on long enough before sweep starts to stabilize external circuits and equipment whose response is compatible with the selected sweep rate; blanking disable switch provided; blanking automatically disabled for power meter leveling.

**Blanking output:** direct-coupled rectangular pulse approximately -4 V coincident with RF blanking; source impedance approximately 3000 ohms.

**Pen lift:** for use with X-Y graphic recorders; penlift terminals shorted during sweep, open during retrace.

**Power leveling amplifier:** internal dc-coupled leveling amplifier provided.

\*Correlation between frequency and both the sweep and reference output.

**Crystal input:** approximately -20 to -350 mV for specified leveling at rated output, for use with negative-polarity detectors such as 780 Series Directional Detectors, 423A and 424 Series Crystal Detectors.

**Power meter input:** 1000 ohm input resistance and amplifier characters matched to recorder output characteristics of 431 Power Meters.

**Modulation**

**Internal AM:** square wave modulation continuously adjustable from 950 to 1050 Hz on all sweep times; on/off ratio greater than 20 dB at rated output.

**External AM**

**Frequency response:** dc to 350 kHz unlevelled, dc to 50 kHz leveled.

**Sensitivity:** -10 V reduced RF level output at least 30 dB below rated CW output.

**Input impedance:** approximately 1000 ohms.

**External FM**

**Frequency response:** dc to 20 kHz.

**Sensitivity:** deviation from CW setting approximately 6% of the frequency band per volt.

**Maximum range:** full band for modulation frequencies up to 150 Hz (approximately 17 V pp input), decreases to about 1% of the band for 20 kHz modulation.

**Input impedance:** approximately 1000 ohms.

**General**

**Power:** 115 or 230 volts ±10%, 50 to 60 Hz; approximately 350 watts.

**Dimensions:** 16 3/4" wide, 9" high, 18 3/8" deep (426 x 229 x 467 mm); hardware furnished for rack mount, 19" wide, 8-23/32" high, 16 3/8" deep behind panel (483 x 221 x 416 mm).

**Weight (not including RF Unit):** net, 53 lbs (23.9 kg); shipping, 71 lbs (32 kg).

**Furnished:** 7 1/2 foot (2290 mm) power cable with NEMA plug; rack mounting kit.

**Available:**

HP K01-8690A Calibrator (page 364), \$280.

HP 8706A Control Unit (pages 362, 363), \$225.

HP 8707A RF Unit Holder (pages 362, 363), \$700.

**Price:** HP 8690A, \$1,550.

**External leveling accessories available**

**Directional detectors:** 780 Series (pages 274, 275), 1 to 12.4 GHz, \$300 to \$350.

**Directional couplers:** coaxial: 790 Series (pages 274, 275), 1 to 8 GHz, \$200 to \$225; waveguide: 752 Series (page 276), 2.6 to 40 GHz, \$125 to \$500.

**Crystal detectors:** coaxial: 423A (page 273), 10 MHz to 12.4 GHz, \$125; waveguide: 424A Series (page 273), 2.6 to 18 GHz, \$135 to \$250 and 422A (page 273), 18 to 40 GHz, \$250.

**Power meter:** 413C (pages 378, 379), \$475.

**Thermistor mounts:** coaxial: 478A (page 379), 10 MHz to 10 GHz, \$155; waveguide: 486A Series (page 379), 2.6 to 40 GHz, \$145 to \$375.

**RF unit specifications, series 8690**

HP Model	Frequency range	Frequency accuracy	Maximum leveled power	RF power control	Frequency stability				Power variation, external leveling*	Output impedance	Output connector	Price	Option 01, Internal leveling		
					With temperature	With 10% change in line voltage	With 10 dB power level change	Residual FM					Power variation	Equivalent source match	Price
8691A	1 to 2 GHz	=1%	≥100 mW	BWO grid	=0.01%/°C	=500 kHz	typically ±20 MHz	<30 kHz peak	=0.2 dB	50 ohms	Type N	\$1875	=0.4 dB	1.13:1	\$315
8691B	1 to 2 GHz	=10 MHz	≥70 mW	PIN line	=0.01%/°C	=500 kHz	=500 kHz	<30 kHz peak	=0.1 dB	50 ohms	Type N	\$2175	—	—	—
8692A	2 to 4 GHz	=1%	≥70 mW	BWO grid	=0.01%/°C	=500 kHz	typically ±40 MHz	<30 kHz peak	=0.2 dB	50 ohms	Type N	\$1675	=0.4 dB	1.16:1	\$315
8692B	2 to 4 GHz	=10 MHz	≥40 mW	PIN line	=0.01%/°C	=500 kHz	=500 kHz	<30 kHz peak	=0.1 dB	50 ohms	Type N	\$1975	—	—	—
H01-8692B	1.7 to 4.2 GHz	=13 MHz	≥15 mW	PIN line	=0.01%/°C	=500 MHz	=500 kHz	<30 kHz peak	=0.1 dB	50 ohms	Type N	\$2275	—	—	—
8693A	4 to 8 GHz	=1%	≥50 mW	BWO grid	=0.01%/°C	=1 MHz	typically ±80 MHz	<50 kHz peak	=0.2 dB	50 ohms	Type N	\$1575	=0.5 dB	1.25:1	\$350
8693B	4 to 8 GHz	=20 MHz	≥15 mW	PIN line	=0.01%/°C	=1 MHz	=1 MHz	<50 kHz peak	=0.1 dB	50 ohms	Type N	\$1900	=0.4 dB	1.25:1	\$350
H01-8693B	3.7 to 8.3 GHz	=25 MHz	≥5 mW	PIN line	=0.01%/°C	=1 MHz	=1 MHz	<50 kHz peak	=0.1 dB	50 ohms	Type N	\$2200	=0.4 dB	1.25:1	\$350
8694A	8 to 12.4 GHz	=1%†	≥50 mW	BWO grid	=0.01%/°C	=1 MHz	†	<50 kHz peak	=0.2 dB	50 ohms	Type N	\$1575	=1.0 dB	2:1	\$375
H01-8694A	7 to 12.4 GHz	=1%†	≥25 mW	BWO grid	=0.01%/°C	=1 MHz	†	<50 kHz peak	=0.2 dB	50 ohms	Type N	\$1850	=1.0 dB	2:1	\$400
H02-8694A	7 to 11 GHz	=1%†	≥25 mW	BWO grid	=0.01%/°C	=1 MHz	†	<50 kHz peak	=0.2 dB	50 ohms	Type N	\$1600	=1.0 dB	2:1	\$375
8694B	8 to 12.4 GHz	=30 MHz	≥30 mW	PIN line	=0.01%/°C	=1 MHz	=1 MHz	<50 kHz peak	=0.1 dB	50 ohms	Type N	\$1925	=0.75 dB	1.5:1	\$375
H01-8694B	7 to 12.4 GHz	=40 MHz	≥15 mW	PIN line	=0.01%/°C	=1 MHz	=1 MHz	<50 kHz peak	=0.1 dB	50 ohms	Type N	\$2200	=0.75 dB	1.5:1	\$400
H02-8694B	7 to 11 GHz	=30 MHz	≥15 mW	PIN line	=0.01%/°C	=1 MHz	=1 MHz	<50 kHz peak	=0.1 dB	50 ohms	Type N	\$1950	=0.75 dB	1.5:1	\$375

\*Excluding coupler and detector variation.  
†Frequency accuracy specified over ≥6 dB range.

HP Model	8695A	8696A	8697A
Frequency range	12.4 to 18 GHz	18 to 26.5 GHz	26.5 to 40 GHz
Frequency accuracy (over a 6 dB range)	=1%	=1%	=1%
Maximum leveled power	≥40 mW	≥10 mW	≥5 mW
Frequency stability with temperature	=0.01%/°C	=0.01%/°C	=0.01%/°C
With 10% change in line voltage	=10 MHz	=15 MHz	=20 MHz
Residual FM	<150 kHz	<200 kHz	<350 kHz
Power variation, external leveling*	=0.2 dB	=0.2 dB	=0.2 dB
Output connector	UG-419/U	UG-595/U	UG-599/U
Price	\$1700	\$2500	\$4300

\*Excluding coupler and detector variation



## RF UNIT

8690A features in a 100 kHz-110 MHz sweeper  
Model 8698A

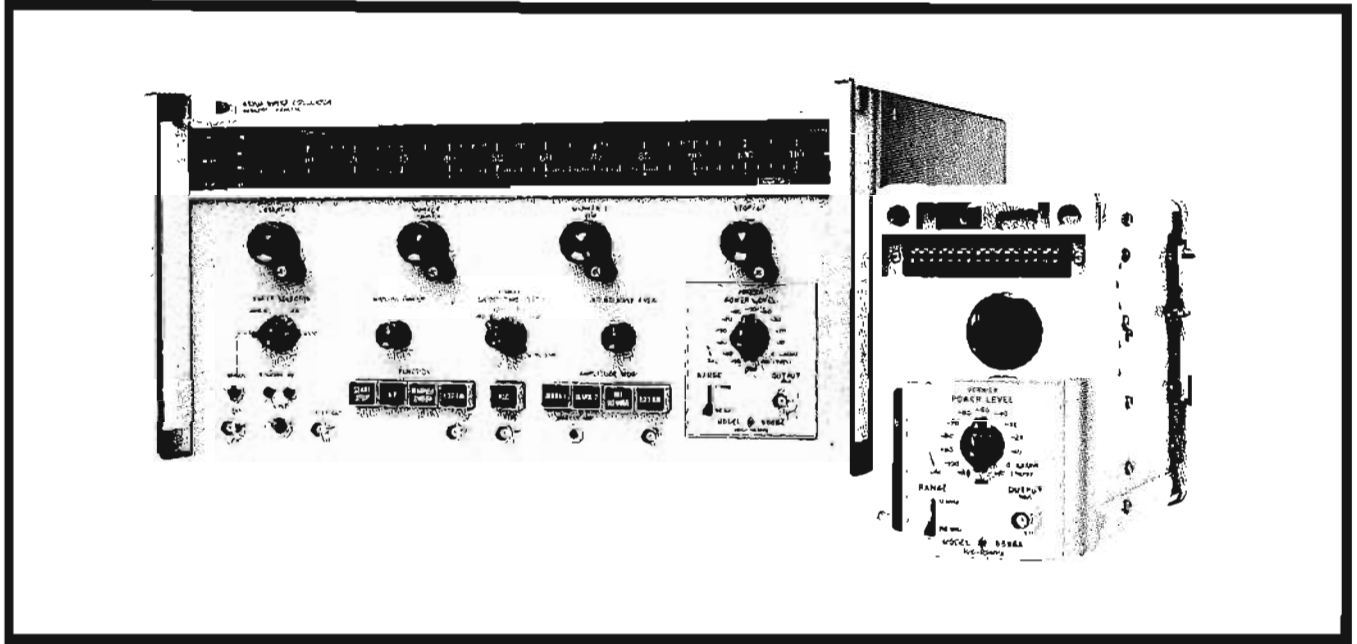

NOW! . . . SATISFY LOW FREQUENCY CW AND SWEEP SIGNAL GENERATOR DESIGN AND TEST APPLICATIONS . . . IF STRIPS — RF COMPONENTS — VIDEO AND OPERATIONAL AMPLIFIERS — RADIO AND TELEVISION CIRCUITS — FILTER PARAMETERS.

### Description

The Model 8698A RF Unit for the Model 8690A Sweep Oscillator is a low frequency sweep signal generator. It covers the frequency range from 100 kHz to 110 MHz in two ranges on a calibrated  $\pm 1\%$  accuracy frequency display. All of the performance features designed into the 8690A Sweep Oscillator for microwave use are retained with the 8698A RF Sweep Signal Generator.

The all solid-state Model 8698A RF Unit makes an outstanding low frequency contribution for several reasons:

- Sweep linearity is exceptionally good, departing less than  $\pm 0.5\%$  from a straight-line function, and frequency accuracy is  $\pm 1\%$ . Residual FM is very low, less than 150 Hz (low range) and 500 Hz (high range). The user is thus able to define the roll-off characteristics of amplifiers and filters accurately.

- Output power is calibrated from +10 to -110 dBm with vernier adjustment between steps. Calibrated power makes it easier to define gain and loss in networks and amplifiers.

- Maximum output is +20 dBm into a 50 ohm load. Output power at this level enables noise-free measurements on networks with high attenuation.

- A built-in leveling circuit holds the output flat within  $\pm 0.25$  dB throughout the maximum sweep width (100

MHz) and flat within  $\pm 0.1$  dB over any 10 MHz portion of the band. This assures accuracy in measuring amplifier and network frequency response.

### Operation

Besides the greater precision and higher accuracy that this RF unit brings into the radio frequency range, there are also operating features of special import. Start and stop sweep points are continuously adjustable and calibrated over the full range, and the instrument sweeps up or down in frequency. Two continuously adjustable markers identify the frequencies of any part of the sweep and can also serve as the end points of another sweep. This marker sweep can be used to expand a small portion of a broadband sweep enabling resolution of displayed discontinuities. A  $\Delta F$  sweep function sweeps over a calibrated frequency range symmetrically on either side of a selected center frequency.

### Design

The accuracy and linearity of the Model 8698A Sweep has never before been approached by a sweep oscillator in this frequency range. To achieve this, a frequency comparator technique uses a pulse count discriminator in a frequency-controlling feedback loop. This discriminator generates a voltage proportional to the frequency output of the RF Unit. This voltage is compared to the linear tuning voltage ramp reference furnished by the 8690A Sweep Oscillator. The

voltage comparison results in tuning voltage compensation applied to a voltage-tuned-oscillator (VTO) to ensure an accurate and linear swept frequency output with time. This technique also substantially reduces residual FM. The output frequency will track an externally applied control voltage faithfully at any deviation rate up to 2 kHz and up to the full 110 MHz frequency deviation range.

The 8698A start-stop type sweep, frequency accuracy and linearity eliminate the need for crystal markers to identify sweep width or points intermediate in the sweep. Frequency settability of  $\pm 1\%$ , low residual FM, and calibrated power output permit the 8698A to satisfy many RF signal generator CW applications.

Two auxiliary outputs, the auxiliary RF output and the VTO output allow a frequency counter to supplement the  $\pm 1\%$  frequency display and provide a second RF output for applications requiring external mixing techniques.

The Model 8698A low frequency sweeper has been designed on a modular building block basis. This enables easy removal of individual operating units for immediate servicing and checking. Cast aluminum block housings minimize

radiated leakage. Test points on the exterior of each modular unit allow easy trouble-shooting to quickly isolate a circuit failure to a basic functional circuit. The Model 10402A Extension Cable, available as an accessory, permits the 8698A to be easily serviced while it is operating outside of the 8690A Sweep Oscillator.

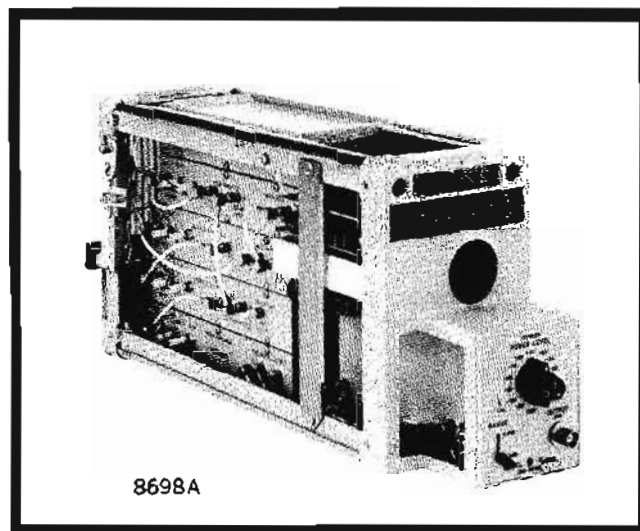

#### RF Unit Specifications, 8698A

**Frequency range:** 0.1 to 11 MHz or 1 to 110 MHz selected by front panel switch.

**Frequency accuracy:** 0.1 to 11 MHz,  $\pm 1\%$  or  $\pm 10$  kHz, whichever is greater; 1 to 110 MHz,  $\pm 1\%$  or  $\pm 100$  kHz, whichever is greater.

**Linearity:**  $\pm 0.5\%$ .

**Residual FM:** 0.1 to 11 MHz,  $< 150$  Hz, peak; 1 to 110 MHz,  $< 500$  Hz, peak.

#### Frequency stability

**With temperature:** 0.1 to 11 MHz,  $\pm 0.01\%/^{\circ}\text{C}$  or  $\pm 200$  Hz/ $^{\circ}\text{C}$ , whichever is greater; 1 to 110 MHz,  $\pm 0.01\%/^{\circ}\text{C}$  or  $\pm 2$  kHz/ $^{\circ}\text{C}$ , whichever is greater.

**With 10% line voltage change:** 0.1 to 11 MHz,  $\pm 5$  kHz; 1 to 110 MHz,  $\pm 50$  kHz.

**Spurious signals:** non-harmonics at least 40 dB below CW output; harmonics at least 35 dB below +10 dBm CW output from 300 kHz to 110 MHz; at least 25 dB below +10 dBm CW output from 100 kHz to 300 kHz.

**Power output:** +20 dBm (2.23 V rms) to -110 dBm adjustable in 10 dB steps; 10 dB vernier permits continuous adjustment between steps.

**Accuracy:**  $\pm 0.5$  dB plus attenuator accuracy (VERNIER in "CAL" position).

**Attenuator accuracy:**  $\pm 1$  dB to 70 dB attenuation;  $\pm 2$  dB to 120 dB attenuation.

**Flatness:** 0.1 to 11 MHz,  $\pm 0.1$  dB; 1 to 110 MHz,  $\pm 0.25$  dB ( $\pm 0.1$  dB over any 10 MHz bandwidth).

**Output impedance:** 50 $\Omega$ .

#### Auxiliary outputs

**Sweep reference:** approximately 1 V/MHz, 0.1 to 11 MHz range; approximately 1V/10MHz, 1 to 110 MHz range.

**Auxiliary RF output:** CW signal corresponding to front panel output at least -15 dBm; harmonic distortion at least 25 dB below CW output.

**VTO output:** 200 to 310 MHz; CW output level at least -10dBm; harmonic distortion 25 dB below CW output.

#### Modulation

**Internal square wave:** 1 kHz rate.

**External AM:** bandwidth 5 kHz.

**External FM:** linearity  $\pm 0.5\%$ ; maximum rate (any deviation) 2 kHz; maximum deviation 110 MHz.

**Price:** HP 8698A, \$950.

#### Accessories available:

HP 10402A Extension Cable for external operation of Model 8698A RF Unit, \$36.

HP 8471A RF Detector; 100 kHz to 1 GHz; 50 ohm; for use with Model 8698A RF Unit; \$40.



## MIXERS, MODULATORS, ATTENUATORS



## EXTEND USEFULNESS, CAPABILITIES, OF OTHER EQUIPMENT

### Attenuators

Attenuators are important tools in the design and testing of electronic components and equipment. They perform a wide variety of functions, particularly in the RF and microwave frequency ranges. For example, fixed attenuators are often used to improve the source match of signal sources and thereby reduce the level of the re-reflected signal. Reduction of this signal is important in measurements requiring high accuracy.

Variable or step attenuators can be used to reduce the power output of signal sources as well as improve source match. The power range of the HP 8690A Sweep Oscillator (see Signal Sources) can be reduced from 10 to 70 dB in this manner.

Extension of the range of power meters and prevention of overload and burn-out of sensitive detectors are additional attenuator applications. Another is the use of precision variable attenuators in the RF substitution method of measuring transmission and reflection characteristics. In this method the attenuator is used to keep the signal level at the detector the same for both the calibration of the system and the actual measurement. The uncertainty of the power response of the detector, generally four to five times the attenuator uncertainty, is thereby eliminated as a factor in measurement accuracy.

Hewlett-Packard manufactures a broad line of attenuators for use in both coaxial and waveguide systems. New to the line is a series of fixed coaxial pads, Models 8491A, 8491B, and 8492A. Based on the development of thin film technology at Hewlett-Packard, these pads operate over the extremely wide frequency range of dc to 12.4 GHz (8491A) and dc to 18 GHz (8491B, 8492A). Attenuation accuracy is high over the entire frequency range as shown in Figure 1. (The data for this figure are based on a sample of 60 8491A 10-dB pads.) Model

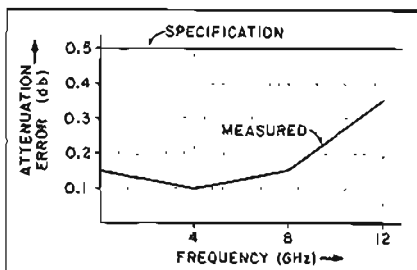

Figure 1. Typical attenuation accuracy of HP 8491A Option 10 10-dB pad.

354A, a coaxial turret attenuator, is another which makes use of thin films. Operating from dc to 12.4 GHz, the 354A provides up to 60 dB of attenuation in 10-dB steps. These and the other attenuators produced by Hewlett-Packard are described in detail on pages 372, 373, and 374.

### Modulators

Sinusoidal and complex modulation of microwave signals is possible with the HP 8730 Series PIN Modulators. The series covers the coaxial range from 0.8 to 12.4 GHz in four overlapping bands in addition to X-band in waveguide. Utilizing PIN diodes, the modulators present a good match and virtually eliminate frequency pulling.

Physically, the PIN modulator comprises a number of PIN diodes mounted as shunt elements across a transmission line. Since PIN diodes have appreciable storage time, they do not rectify at signal frequencies above 100 MHz. However, when a dc forward bias is applied, the diodes conduct, and their resistance goes down. Thus, the diodes act as low-reactance, variable resistors shunting the transmission line. Their resistance, and the degree of attenuation of an rf signal, are functions of the modulating current.

New modulation techniques are possible with the HP modulators, since they may be connected in series for compound modulation, such as amplitude modulation of rf pulses.

Two models of PIN modulators are available within each band: one which provides at least 35 dB of attenuation range, and one which provides at least 80 dB.

The 35 dB version is especially useful as the control element in a closed-loop system for microwave power leveling. Conventional amplitude modulation also can be accomplished. The 80 dB modulators provide high on/off ratios for critical pulse-modulation applications. The modulators are capable of achieving pulse rise and fall times of typically 30 nanoseconds. The HP Model 8403A Modulator provides complete control of the PIN modulators, supplying the appropriate modulation wave shapes and bias levels for fast rise times, rated on/off ratios and amplitude modulation.

### Double balanced mixer

The Hewlett-Packard Double Balanced Mixer, Model 10514A, is a versatile device of broadband (200 kHz to 500 MHz) application that can serve as a

mixer, modulator, attenuator, or phase detector. This exceptional versatility in a unit that measures 2.3 x 0.6 x 1.7 inches is made possible by circuitry that takes full advantage of specially developed transformers and specially selected hot carrier diodes produced by HP Associates. A truly low noise device, the 10514A has a 7 dB maximum noise figure to 50 MHz and a 9 dB maximum noise figure to 500 MHz.

One of the ports of the mixer is coupled to dc, allowing its efficient operation as a low-noise phase detector, as an amplitude or pulse modulator, and as a current-controlled attenuator.

Figure 2 shows the circuit diagram of the 10514A, with ports marked "L", "R", and "X". This circuit is commonly known as a double-balanced or ring modulator.

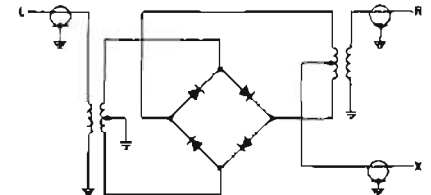

Figure 2. Schematic diagram

For mixing, with rf input signals at L and R, the output at X contains the sum and difference frequencies. For phase detecting and doubling, L and R are at the same frequency; their sum is twice the input, their difference is dc; and the desired output can be selected by a high-pass, low-pass or bandpass filter at X.

When the mixer is to serve as a current-controlled attenuator, balanced modulator, or amplitude or pulse modulator, the control or modulating signal is connected at X and the output taken from R. With a dc current applied at X, output at R is attenuated in an amount inversely proportional to applied current. With an rf signal at L and a modulating signal at X, the output at R is the rf frequency plus and minus the modulating frequency; the carrier is suppressed as in a balanced modulator. Amplitude and pulse modulation are combinations of the effects already described.

This versatile mixer fills many needs that formerly could be satisfied only by a narrow band specially-built laboratory device.

A new generation of mixers is presently being developed and will be available in early 1967. Models will include printed circuit devices, and will operate over several frequency ranges. Consult Hewlett-Packard for further information.

## DOUBLE BALANCED MIXER

High performance simplifies many design tasks  
Model: 10514A



MIXERS, MODULATORS,  
ATTENUATORS

### Advantages:

- Wide-band, low-noise performance that compares favorably with narrow-band mixers of limited usefulness
- Excellent balance at all ports
- Flat response
- Low insertion loss
- Low intermodulation products
- Rugged, environmentally type-tested

### Uses:

- As a mixer for extracting the sum or difference of two frequencies as in a receiver tuned voltmeter or wave analyzer. High degree of carrier suppression greatly reduces filter requirements in single sideband systems.
- As a frequency doubler for very flat-response, low-noise frequency doubling.
- As a suppressed carrier modulator with 45 dB typical carrier rejection at hF.
- As a pulse modulator or spectrum generator with precise turn-on and turn-off characteristics.
- As a current-controlled attenuator where the level of a signal (at the mixer "L" port) is to be attenuated linearly with respect to a dc current (at the "X" port); a dc current change from 10 microamperes to 10 milliamperes causes signal attenuation from 48 dB to 3 dB, respectively (typical); insertion loss and harmonics are low; linear range is 30 dB.
- As a phase detector with low-noise and dc coupling that permit phase or frequency stability measurement on the most stable, high-quality signal sources and quartz crystals.

### Specifications

**Input/output frequencies:** "L" and "R" ports: 200 kHz to 500 MHz; "X" port: dc to 500 MHz.

**Maximum input:** 40 mA (damage level).

**Impedance:** designed for and spec'd in 50  $\Omega$  system.

**Mixer conversion loss:** (single sideband):

- (A) 7 dB max. for  $f_L$  and  $f_R$  in the 500 kHz to 50 MHz range and  $f_X$  from dc to 50 MHz.
- (B) 9 dB max. for  $f_L$  and  $f_X$  in the 200 kHz to 500 MHz range and  $f_R$  from dc to 500 MHz.

**Noise performance** (single sideband):

- 7 dB max. noise figure for conditions of (A) above except  $f_X$  min. frequency of 50 kHz.
- 9 dB max. noise figure for conditions of (B) above except  $f_X$  min. frequency of 50 kHz.
- $10^{-4}$  volts per root cycle max. expected at output for conditions of (A) or (B) except  $f_X$  at 10 cycles.

**Mixer balance:**

As In (A)	As In (B)	
40 dB	30 dB	$f_L$ at R with $f_L$ reference
40	20	$f_L$ at X with $f_L$ reference
45	30	$f_R$ at L with $f_R$ reference
25	15	$f_R$ at X with $f_R$ reference
35	15	$f_X$ at L with $f_X$ reference
25	15	$f_X$ at R with $f_X$ reference

**Typical conversion compression:** by  $f_R$  alone; 0.3 dB for 1 mW level. By  $f_{R2}$  signal presence interfering with  $f_{R1}$  signal: 1 dB for  $f_{R2}$  level of 1 mW; 10 dB for  $f_{R2}$  level of 10 mW.

**Intermodulation:** typical intermodulation product production with  $f_L$  level of 5 mW and  $f_R$  at 70 mV:

Product	Level*	Product	Level*
$2f_L - f_R$	30 dB	$2f_R - f_L$	65 dB
$3f_L - 2f_R$	70	$3f_R - 2f_L$	65
$4f_L - 3f_R$	70	$4f_R - 3f_L$	85
$5f_L - 4f_R$	90	$5f_R - 4f_L$	90
$6f_L - 5f_R$	95	$6f_R - 5f_L$	> 100
$7f_L - 6f_R$	> 100	$7f_R - 6f_L$	> 100

\* Referred to  $f_X$  level

**Typical pulse modulator performance** (pulse input at "X," output at "R"):

**Rise or fall times:** <1 nanosecond.

**Pulse width:** no restriction.

**On-off ratio:** 35 dB.

**Saturation pulse amplitude:** 10 mA with  $f_L = 5$  mW.

**Maximum input:** 40 mA (damage level).

**Modulation source:** either + or - polarity turns switch on. Amplitude between pulses, within 2 mV of 0 V.

**Linearity:** output is linear over a 30 dB input current range at 500 MHz; better at lower frequencies.

**Connectors:** female BNC.

**Environmental:** mixer has been type tested to meet its specifications over  $-20^\circ\text{C}$  to  $+65^\circ\text{C}$  and through five cycles of  $40^\circ\text{C}$  and 95% humidity. Compliance with the rigid MIL-I-6181D RFI specification has been demonstrated. Non-operating tests include  $-40^\circ\text{C}$  to  $+75^\circ\text{C}$  exposure, 0.060 inch peak-to-peak vibration to 55 Hz, 4 inch bench drops, and altitude to 25,000 feet.

**Dimensions:** 2.3 in. x 0.6 in. x 1.7 in. (59 x 15 x 43 mm).

**Mounting:** tapped 4.40 NC hole pair on 2.062 inch centers on connector side.

**Weight:** 2.1 oz (59 grams).

**Price:** \$180.00 (consult HP for quantity prices).

NOTE: All specifications are for 50 $\Omega$  terminations and  $F_L$  level of 5 mW. Special units are available with improved noise specifications or with improved, specific, port-to-port balance specifications. Also, consult HP on other connectors, mountings and sizes.

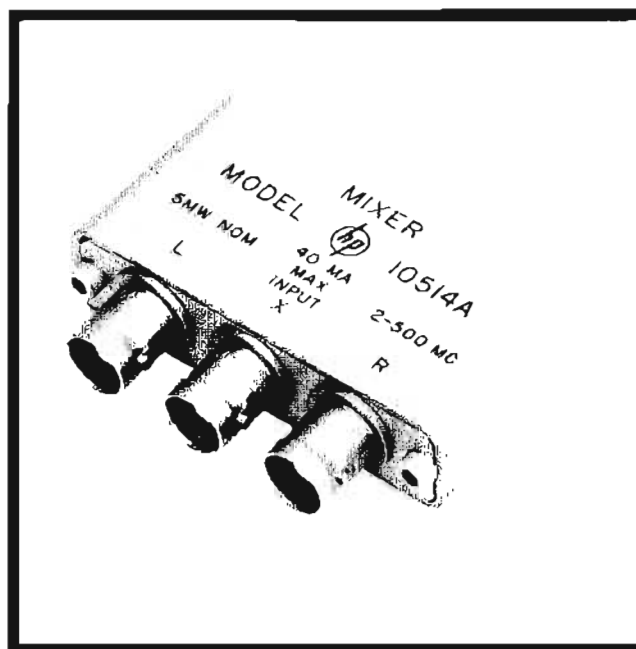



### 8730 PIN Modulators

The Hewlett-Packard 8730 Series PIN Modulators increase the flexibility and performance of signal generators and sources by providing increased modulation capability. With PIN modulators, signal sources, including klystrons, can be pulse modulated, leveled or amplitude modulated with sinusoidal and complex waveforms. Incidental FM is virtually eliminated, because modulation is accomplished by absorption of rf power, independent of the signal source, with a nearly constant match presented to both the source and load. Thus, the source can operate continuously at its optimum output level. Extremely fast rise times, typically 30 nsec, also result from the absorption type of modulation, which sidesteps the bandwidth limitations imposed by the high-Q rf output circuits.

The 8730 PIN Modulators cover the coaxial range from 0.8 to 12.4 GHz in four overlapping bands, in addition to X-band in waveguide. Two models are available within each band: an "A" model, which provides at least 35 dB of attenuation range, and a "B" model, which provides at least 80 dB.

Physically, the PIN modulator comprises a number of PIN diodes mounted as shunt elements across a transmission line. Since PIN diodes have appreciable storage time, they do not rectify at signal frequencies above 100 MHz. However, when a dc forward bias is applied, the diodes conduct, and their resistance goes down. Thus, the diodes act as low-reactance, variable resistors shunting the transmission line. Their resistance and the degree of attenuation of an rf signal are functions of the modulating current. However, due to the storage time of the diodes, specially shaped modulation signals must be applied to realize the fast rf rise and decay times of which the PIN modulators are capable. The HP Model 8403A Modulator is specifically designed to supply these modulation signals.

### 8403A Modulator

The Model 8403A provides complete control of the PIN modulators, supplying the appropriate modulation wave shapes and bias levels for fast rise times, rated on/off ratios and amplitude modulation. An internal square-wave and pulse modulator, which can be synchronized with external signals, has a free-running prf from 50 Hz to 50 kHz. In the pulse-modulation mode both pulse width and pulse delay are adjustable from 0.1 to 100  $\mu$ sec, and jitter with respect to the sync pulse and pulse width is less than 1 nsec. An external AM input permits remote control of attenuation or sinusoidal modulation from dc to 10 MHz.

The Model 8403A also provides square wave and pulses for general pulse applications. Repetition rate, delay and jitter are the same as above. The output signal has an amplitude of 25 to 30 volts.

For situations requiring an absorption-type modulator complete with controls in a single unit, a PIN modulator can be installed in the Model 8403A. This combination is fully portable and convenient for bench use.

### Specifications, 8403A

#### Output characteristics

AM and pulse output for driving 8730 PIN Modulators: pulse output specially shaped for optimum rf rise and decay times.

Pulse output for general pulse applications: positive dc-coupled pulse 25 to 30 volts in amplitude, approximately symmetrical about 0 volt; no AM signal.

Output signals available concurrently from separate front-panel connectors.

#### Internal modulation

##### Square wave

Frequency: continuously variable from 50 Hz to 50 kHz, 3 decade ranges.

Symmetry: better than 45/55%.

##### Pulse

Repetition rate: continuously variable from 50 Hz to 50 kHz, 3 decades ranges.

Delay: continuously variable from 0.1  $\mu$ sec to 100  $\mu$ sec, in 3 decade ranges, between sync out pulse and rf output pulse.

Width: continuously variable from 0.1  $\mu$ sec to 100  $\mu$ sec in 3 decade ranges.

Maximum duty cycle: see graph.

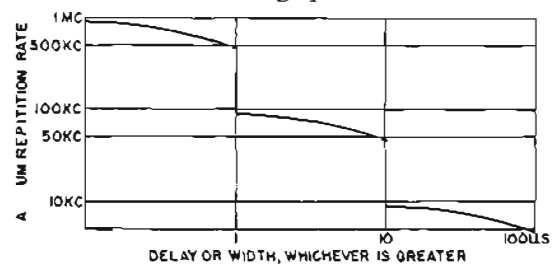

#### External sync

Amplitude: 5 volts to 20 volts peak.

Waveform: pulse or sine wave.

Polarity: either positive or negative.

Input impedance: approx. 2000 ohms, dc-coupled.

Rate: subject to internal recovery time considerations; see graph.

#### Trigger out

Sync out: 0.1 to 100  $\mu$ sec in advance of rf pulse, as set by Delay control (internal pulse mode); simultaneous with rf pulse (internal square wave and external pulse mode).

Delayed sync out: simultaneous with output pulse (internal pulse mode only).

Amplitude: approximately -2 volts.

Source impedance: approximately 330 ohms.

#### External modulation

##### Pulse Input

Amplitude and polarity: 5 volts to 20 volts peak, either positive or negative.

Repetition rate: maximum average prf, 500 kHz.

Input impedance: approx. 2000 ohms, dc-coupled.

Minimum width: 0.1  $\mu$ sec.

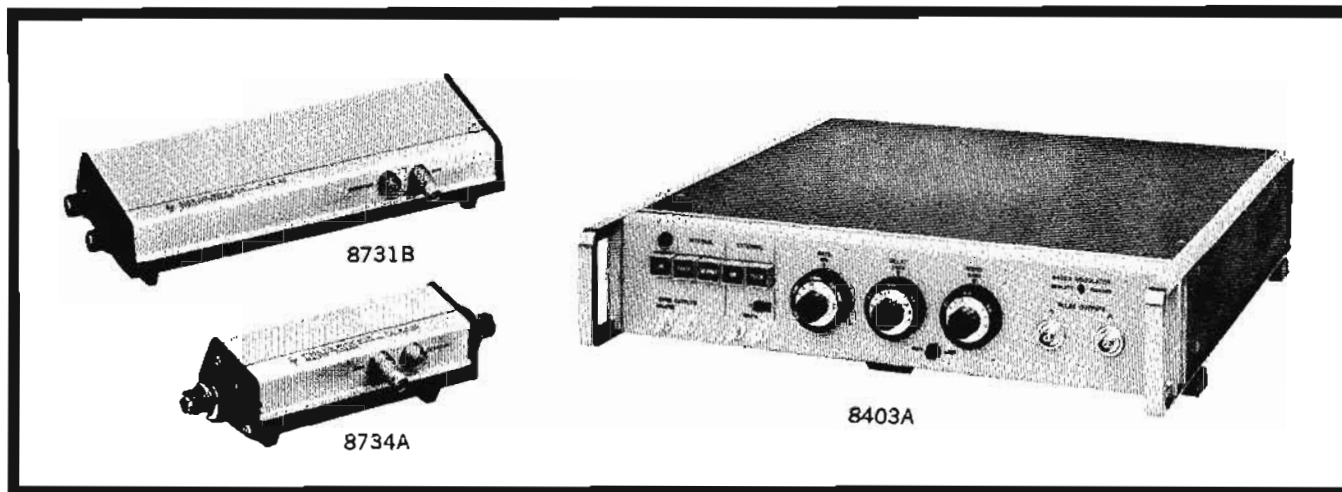

Maximum width:  $\frac{1}{prf} - 0.4 \mu\text{sec}$ .

Continuous amplitude modulation (with 8730 Series)

Frequency response: dc to approximately 10 MHz (3 dB).

Sensitivity: approximately 10 dB/volt with HP 8730A Series, approximately 20 dB/volt with HP 8730B Series.

Input impedance: approximately 1000 ohms.

Level control: AM input is dc-coupled, permitting control by bias of AM input; rear-panel control for use with ac-coupled modulation.

#### General

Power: 115 or 230 volts  $\pm 10\%$ , 50 to 400 Hz, approximately 10 watts.

Dimensions: 16 $\frac{3}{4}$ " wide, 3 $\frac{3}{4}$ " high, 18 $\frac{3}{8}$ " deep (425 x

96 x 467 mm); hardware furnished for conversion to rack mount 19" wide, 3-15/32" high, 16 $\frac{3}{8}$ " deep behind panel (483 x 88 x 416 mm).

Weight: net 16 $\frac{1}{2}$  lbs (7.4 kg); shipping 20 lbs (9 kg).  
Price: HP 8403A, \$700.

#### Options

01. HP 8731A PIN Modulator installed, add \$350.
02. HP 8731B PIN Modulator installed, add \$575.
03. HP 8732A PIN Modulator installed, add \$350.
04. HP 8732B PIN Modulator installed, add \$575.
05. HP 8733A PIN Modulator installed, add \$375.
06. HP 8733B PIN Modulator installed, add \$600.
07. HP 8734A PIN Modulator installed, add \$400.
08. HP 8734B PIN Modulator installed, add \$625.
09. Sync output and external modulation input connectors on rear panel in parallel with front-panel connectors; pulse output ( or rf input , output ) connectors on rear panel only, add \$25.

#### Specifications, 8730 Series

HP Model	8731A	8731B	8732A	8732B	8733A	8733B	8734A	8734B	8735A	8735B
Frequency range (GHz)	0.8-2.4	0.8-2.4	1.8-4.5	1.8-4.5	3.7-8.3	3.7-8.3	7.0-12.4	7.0-12.4	8.2-12.4	8.2-12.4
Dynamic range (dB)	35	80	35	80	35	80	35	80	35	80
Max. residual atten. (dB) <sup>1</sup>	<1.5	<2.0	<2.0	<3.5 <sup>2</sup>	<2.0	<3.0	<4.0	<5.0	<4.0	<5.0
Typical rise time (nsec) <sup>3</sup>	40	30	40	30	30	30	30	30	30	30
Typical decay time (nsec) <sup>3</sup>	30	20	30	20	20	20	20	20	20	20
SWR, min. attenuation	1.5	1.6	1.5	1.6 <sup>4</sup>	1.8	2.0	1.8	2.0	1.7	2.0
SWR, max. attenuation	1.8	2.0	1.8	2.0	2.0	2.2	2.0	2.2	2.0	2.2
Forward bias input resistance (ohms)	300	100	300	100	300	100	300	100	300	100
RF connector type	N	N	N	N	N	N	N	N	W/G <sup>5</sup>	W/G <sup>5</sup>
Weight, net (lbs) (kg)	3 (1.4)	5 $\frac{1}{2}$ (2.5)	3 (1.4)	5 $\frac{1}{2}$ (2.5)	2 $\frac{1}{2}$ (1.1)	3 $\frac{1}{2}$ (1.6)	2 $\frac{1}{2}$ (1.1)	3 $\frac{1}{2}$ (1.6)	2 $\frac{1}{2}$ (1.1)	3 $\frac{1}{2}$ (1.6)
Weight, shipping (lbs) (kg)	4 (1.8)	9 (4.1)	4 (1.8)	9 (4.1)	4 (1.8)	5 (2.3)	4 (1.8)	5 (2.3)	4 (1.8)	5 (2.3)
Dimensions										
Length (in) (mm)	11 $\frac{1}{4}$ (283)	11 $\frac{1}{4}$ (289)	11 $\frac{1}{4}$ (283)	11 $\frac{1}{4}$ (289)	8 $\frac{3}{4}$ (213)	12 $\frac{1}{4}$ (311)	8 $\frac{3}{4}$ (213)	12 $\frac{1}{4}$ (311)	6 $\frac{3}{4}$ (171)	10 $\frac{1}{2}$ (267)
Width (in) (mm)	3 $\frac{1}{4}$ (83)	4 $\frac{1}{8}$ (124)	3 $\frac{1}{4}$ (83)	4 $\frac{1}{8}$ (124)	3 $\frac{1}{4}$ (83)	3 $\frac{1}{4}$ (83)	3 $\frac{1}{4}$ (83)	3 $\frac{1}{4}$ (83)	3 $\frac{1}{4}$ (83)	3 $\frac{1}{4}$ (83)
Height (in) (mm)	2 $\frac{1}{4}$ (57)	2 $\frac{1}{4}$ (57)	2 $\frac{1}{4}$ (57)	2 $\frac{1}{4}$ (57)	2 $\frac{1}{4}$ (57)	2 $\frac{1}{4}$ (57)	2 $\frac{1}{4}$ (57)	2 $\frac{1}{4}$ (57)	2 $\frac{1}{4}$ (57)	2 $\frac{1}{4}$ (57)
Price	\$300	\$525	\$300	\$525	\$325	\$550	\$350	\$575	\$350	\$575

Maximum ratings: maximum input power, peak or cw: 1W; bias limits: +20 V, -10 V. Bias polarity: negative voltage increases attenuation. RFI: radiated leakage limits are below those specified in MIL-I-61810 at input levels less than 1 mW; at all input levels radiated interference is sufficiently low to obtain rated attenuation.

<sup>1</sup> With +5 V bias.

<sup>2</sup> 4 dB, 4 to 4.5 GHz.

<sup>3</sup> Driven by HP 8403A Modulator.

<sup>4</sup> 2.0 swr, 4 to 4.5 GHz.

<sup>5</sup> Fits 1 x 1/2 in. (WR90) waveguide.

## MIXERS, MODULATORS, ATTENUATORS



## VARIABLE COAXIAL ATTENUATOR

Versatile application to 2 GHz

Models 355C,D, 393A, 394A

### 355C,D VHF Attenuators

Unique design provides accurate attenuation from dc to 1 GHz with the HP 355C (0 to 12 dB in 1 dB steps) and HP 355D (0 to 120 dB in 10 dB steps). Attenuator sections are inserted and removed by cam-driven microswitches. These sections are adjusted by a time-domain reflectometry system to minimize reflections and assure high accuracy. Insertion loss is low, and using both instruments provides attenuation in 1 dB steps to 132 dB. The units can be connected with either terminal as input or output, and their small size and mounting versatility permit several installation schemes—even within other equipment.

### 393A, 394A Coaxial Attenuators

Each of these coaxial variable attenuators uses the principle of a directional coupler (see Figure 1) to achieve a wide range of attenuation over a full octave. The HP 393A covers 5 to 120 dB from 500 to 1000 MHz; HP 394A covers 6 to 120 dB from 1 to 2 GHz. With special high-power terminations, they will handle up to 200 watts average.

Since these instruments are variable directional couplers, they are particularly useful for mixing signals while maintaining isolation.

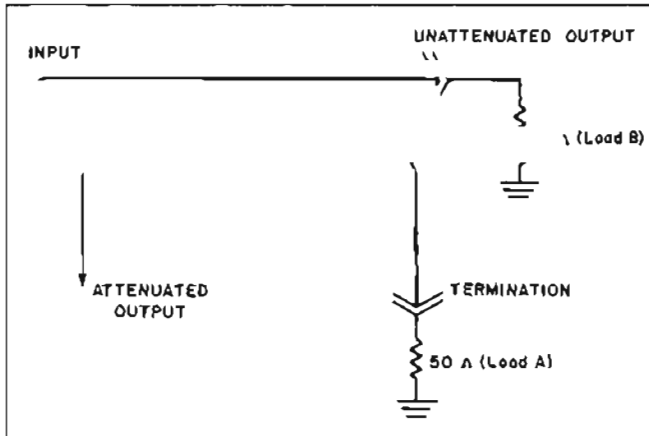
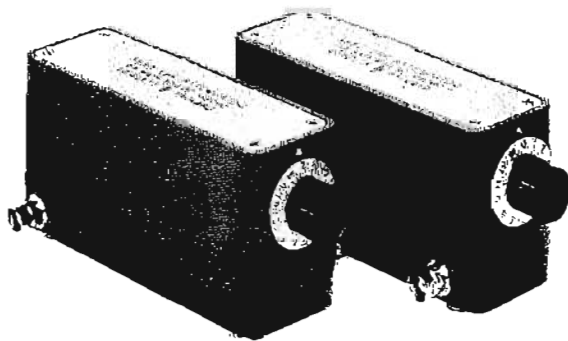

Figure 1. With loads A and B in place the instrument is an attenuator. With load A only, the instrument is a variable directional coupler.

Specifications	355C	355D
Attenuation:	12 dB in 1 dB steps	120 dB in 10 dB steps
Frequency range:	dc to 1 GHz	
Overall accuracy:	±0.1 dB at 1000 Hz; ±0.25 dB dc to 500 MHz; ±0.35 dB dc to 1 GHz	±0.3 dB to 120 dB at 1000 Hz; ±1.5 dB to 90 dB below 1 GHz; ±3 dB to 120 dB below 1 GHz
Impedance:	50 ohms nominal	
Maximum swr (input and output):	1.2 below 250 MHz; 1.3 below 500 MHz; 1.5 below 1 GHz	
Maximum insertion loss:	0.25 dB at 100 MHz; 0.75 dB to 500 MHz; 1.5 dB to 1 GHz	
Dimensions:	6" long, 2 1/4" wide, 2 3/8" high (152 x 70 x 67 mm)	
Weight:	net 1 1/2 lbs (0.7 kg); shipping 3 lbs (1.4 kg)	
Price:	HP 355C, \$150	HP 355D, \$150

Specifications	393A	394A
Attenuation or coupling:	5 to 120 dB, variable	6 to 120 dB, variable
Directivity (with loads less than 1.05 swr):	typically 10 dB, 10 to 40 dB attenuation	
Absolute accuracy (between matched generator and load):	±1 dB or ±1% of dial reading, whichever is greater	±1.25 dB or ±2.5% of dial reading, whichever is greater
SWR input:	<2.5, 5 to 15 dB attenuation <1.5, 15 to 30 dB attenuation <1.2, 30 to 120 dB attenuation	<2.5, 6 to 10 dB attenuation <1.8, 10 to 15 dB attenuation <1.6, 15 to 120 dB attenuation
SWR output:	<2.5, 5 to 15 dB attenuation <1.5, 15 to 30 dB attenuation <1.4, 30 to 120 dB attenuation	<2.5, 6 to 10 dB attenuation <1.8, 10 to 15 dB attenuation <1.6, 15 to 120 dB attenuation
Impedance:	50 ohms nominal	
Maximum voltage:	500 volts peak	
Average power:	approx. 200 watts maximum; power rating of terminations must be observed (908A, 0.5 watt terminations furnished)	
Dimensions:	5 1/2" wide, 12" long, 2 3/4" deep (140 x 305 x 70 mm)	
Weight:	net 6 lbs (2.7 kg); shipping 13 lbs (5.8 kg)	
Price:	HP 393A, \$525	HP 394A, \$550
Option 01:	supplied without 908A coaxial terminations, less \$70	



355C,D

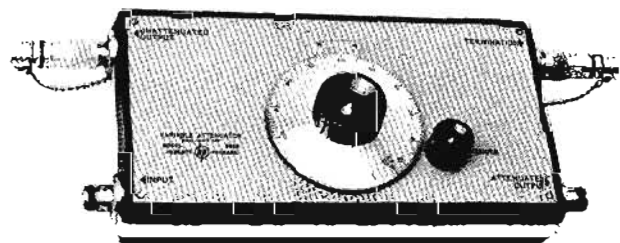

393A

## COAXIAL ATTENUATORS

A new concept in attenuation  
Models 354A, 8491A,B, 8492A



**MIXERS, MODULATORS,  
ATTENUATORS**

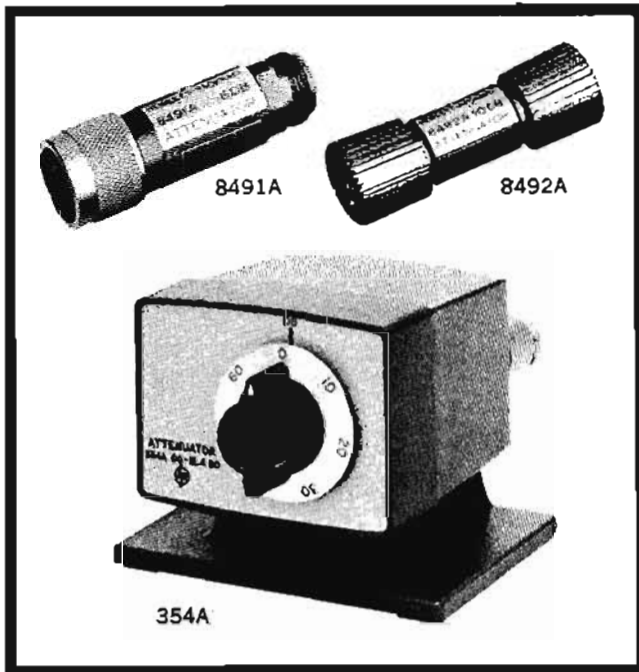

The HP 354A, 8491A,B, and 8492A Coaxial Attenuators are the direct result of the development of thin-film technology at Hewlett-Packard. In these instruments, a thin resistive film deposited on a ceramic card forms the attenuation element. The card is inserted in a precision housing for mounting in the attenuator body. The end product is a series of attenuators and pads, fundamental tools in all phases of electronic engineering, which are broad band with flat response and low swr.

### Broad-band pads

The HP 8491A,B and 8492A are fixed coaxial pads. The 8491A operates from dc to 12.4 GHz, the 8491B and 8492A from dc to 18 GHz. Capable of handling 2 watts, these economical pads are excellent wherever power reduction is required. Nominal attenuation (3, 6, 10, and 20 dB) is determined by the option number, e.g. 8491A Option 10 is a 10-dB pad. Higher values are also available. Actual attenuation values are indicated on the nameplates at specific frequencies, and each pad is swept-frequency tested for attenuation and swr over critical parts of the band.

### Turret attenuator

A turret-type attenuator, HP Model 354A provides 0 to 60 dB of attenuation in 10-dB steps. Its small, convenient size makes it well suited for bench-top use, and the base is removable for easy conversion to a panel mount for system or instrumentation applications. Operating from dc to 12.4 GHz, the 354A is valuable in multi-octave tests which otherwise require two or more narrow-band attenuators. Attenuation is changed with a simple knob rotation. Input and output connectors, type N female, are on the rear.

### Specifications, 8491A,B, 8492A

**Frequency range:** 8491A, dc to 12.4 GHz; 8491B and 8492A, dc to 18 GHz.

**Nominal attenuation:** Option 03, 3 dB; Option 06, 6 dB; Option 10, 10 dB; Option 20, 20 dB.

**Attenuation accuracy:**

8491A: Option 03:  $\pm 0.3$  dB; Option 06: dc to 7 GHz,  $\pm 0.3$  dB; 7 to 12.4 GHz,  $\pm 0.4$  dB; Option 10:  $\pm 0.5$  dB; Option 20: dc to 7 GHz,  $\pm 0.5$  dB; 7 to 12.4 GHz,  $\pm 1$  dB.  
8491B and 8492A: Option 03:  $\pm 0.3$  dB; Option 06: dc to 12 GHz,  $\pm 0.3$  dB; 12 to 18 GHz,  $\pm 0.4$  dB; Option 10:  $\pm 0.5$  dB; Option 20: dc to 12 GHz,  $\pm 0.5$  dB; 12 to 18 GHz,  $\pm 1$  dB.

**Calibration frequencies:** 8491A: 0, 4, 8, and 12.4 GHz; 8491B and 8492A: 0, 4, 8, 12, and 18 GHz.

**Impedance:** 50  $\Omega$ .

**SWR (either connector):**

8491A: Option 03: dc to 7 GHz, 1.25; 7 to 12.4 GHz, 1.35; Options 6, 10, and 20: dc to 7 GHz, 1.2; 7 to 12.4 GHz, 1.3.  
8491B: Option 03: dc to 7 GHz, 1.25; 7 to 12 GHz, 1.35; 12 to 18 GHz, 1.5; Options 06, 10, and 20: dc to 7 GHz, 1.2; 7 to 12 GHz, 1.3; 12 to 18 GHz, 1.5.  
8492A: Option 03: dc to 8 GHz, 1.2; 8 to 12 GHz, 1.3; 12 to 18 GHz, 1.5; Option 06: 0 to 8 GHz, 1.2; 8 to 12 GHz, 1.3; 12 to 18 GHz, 1.35; Options 10 and 20: dc to 8 GHz, 1.15; 8 to 12 GHz, 1.25; 12 to 18 GHz, 1.35.

**Maximum input power:** 2 W average.

**Connectors:** 8491A and 8491B: stainless steel type N, one male, one female; 8492A: APC-7.

**Dimensions:** 8491A and 8491B: 2-7/16 in. long, 13/16 in. in diameter (62 x 21 mm); 8492A: 2-3/4 in. long, 13/16 in. in diameter (70 x 21 mm).

**Weight:** net, 3-1/2 oz (100 g); shipping, 8 oz (220 g).

**Price:** (including option): 8491A, \$50; 8491B, \$65; 8492A, \$125.

**Options (Specify one):** 03: 3-dB nominal attenuation; 06: 6-dB nominal attenuation; 10: 10-dB nominal attenuation; 20: 20-dB nominal attenuation.

### Specifications, 354A

**Frequency range:** dc to 12.4 GHz.

**Incremental attenuation:** 0 to 60 dB in 10-dB steps.

**Accuracy (including frequency response):**  $\pm 2$  dB.

**Residual attenuation:** less than 1.5 dB.

**SWR:** 0 to 8 GHz,  $\leq 1.5$ ; 8 to 12.4 GHz,  $\leq 1.75$ .

**Maximum power:** 2 W.

**Connectors:** type N female, stainless steel.

**Dimensions (maximum envelope):** 4 in. wide, 3-1/8 in. high, 4-1/2 in. deep (102 x 79 x 114 mm); panel mount, 3-1/16 in. wide, 2-5/16 in. high, 3-3/4 in. deep behind panel (78 x 59 x 95 mm).

**Weight (with base):** net 2-3/4 lb (1.2 kg); shipping 4 lb (1.8 kg).

**Price:** Model 354A, \$350.

## MIXERS, MODULATORS, ATTENUATORS



## VARIABLE ATTENUATORS

Frequency coverage to 40 GHz

Models 382A, B, C and 375A

### Precision Variable Attenuators

Operation of these direct-reading, precision attenuators depends on a mathematical law, rather than on the resistivity of the attenuating material. Accurate attenuation from 0 to 50 dB (0 to 60 dB for S382B,C) is assured regardless of temperature and humidity. The

instruments can handle considerable power and feature large, easily read dials. In addition, the S382B,C achieve both long electrical length and short physical dimensions through dielectric loading. The result is an S-band attenuator which is only 2 3/4 in. long and yet is more accurate than previously available units.

HP Model	S382B,C	G382A	J382A	H382A	X382A	P382A	K382A*	R382A*
Frequency range (GHz):	2.6-3.95	3.95 - 5.85	5.3 - 8.2	7.05 - 10.0	8.2 - 12.4	12.4 - 18.0	18.0 - 26.5	26.5 - 40.0
Waveguide size (in.): (EIA):	3 x 1 1/2 WR284	2 x 1 WR187	1 1/2 x 3/4 WR137	1 1/4 x 3/8 WR112	1 x 1/2 WR90	.702 x .391 WR62	1/2 x 1/4 WR42	.360 x .220 WR28
Power handling capacity, watts, average continuous duty:	10	15	10	10	10	5	2	1
Size length, in. (mm): height, in. (mm): depth, in. (mm):	25 1/4 (641) 6 (152) 8 (203)	31 1/8 (803) 9 3/8 (245) 7 1/4 (197)	25 1/8 (638) 7-15/16 (202) 6 1/2 (165)	20 (508) 7-15/16 (202) 6 1/2 (165)	15 5/8 (397) 7 3/8 (194) 4-11/16 (119)	12 1/2 (318) 7 1/4 (197) 4 3/4 (121)	7 3/8 (194) 5 1/2 (140) 3 3/8 (92)	6-7/16 (164) 5 1/2 (140) 3 3/8 (92)
Weight net, lb (kg): shipping, lb (kg):	18 (8.1) 28 (12.6)	25 (11.3) 32 (14.4)	12 (5.4) 24 (10.8)	10 (4.5) 22 (9.9)	5 (2.3) 8 (3.6)	5 (2.3) 9 (4.1)	4 (1.8) 9 (4.1)	4 (1.8) 9 (4.1)
Price:	\$650 (S382B) \$700 (S382C)	\$500	\$375	\$350	\$275	\$300	\$475	\$500

### For all 382A Models

**Calibrated attenuation range:** 0 to 50 dB (above residual attenuation).

**Residual attenuation:** less than 1 dB.

**Phase shift variation:** less than 3° from 0 to 50 dB.

**Reflection coefficient:** less than 0.07 (1.15 swr, 23.1 dB return loss).

**Accuracy:** ±2% of reading in dB, or 0.1 dB, whichever is greater. Includes calibration and frequency error.

### For S382B, C Models

**Calibrated attenuation range:** 0 to 60 dB (above residual attenuation).

**Residual attenuation:** less than 1 dB.

**Accuracy:** ±1% of reading in dB, or 0.1 dB, whichever is greater, from 0 to 50 dB; ±2% of reading above 50 dB; includes calibration and frequency error.

**Phase shift variation:** less than 3° from 0 to 60 dB.

**Reflection coefficient:** less than 0.091 (1.2 swr, 20.8 dB return loss), 2.6 to 3 GHz; less than 0.07 (1.15 swr, 23.1 dB return loss), 3 to 3.95 GHz.

**Degree dial:** 0 to 90°; S382B calibrated in 0.1° increments; S382C calibrated in 0.01° increments.

\*Circular flange adapters: K-band (UG-425/U) 11515A, \$35 each; R-band (UG-381/U) 11516A, \$40 each.

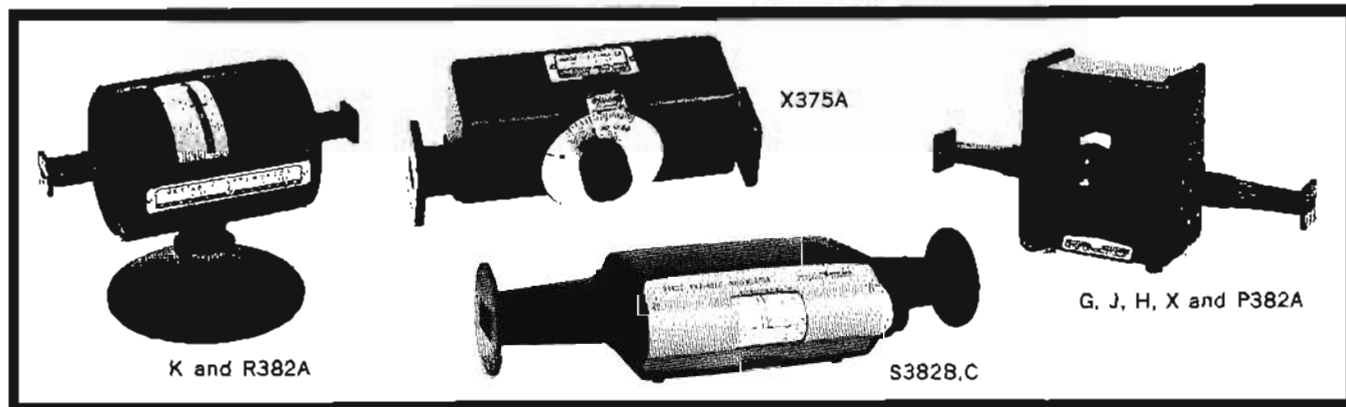

### General Purpose Attenuators

Variable flap attenuators provide a simple, convenient means of adjusting waveguide power level or isolating source and load. They consist of a slotted section in which a matched resistive strip is inserted. The degree of strip penetration determines attenuation. A dial shows average reading over the frequency band, and a shielded dust cover reduces external radiation and eliminates hand capacity effects. Attenuation is variable from 0 to 20 dB. Dial calibration is accurate within ±1 dB from 0 to 10 dB, ±2 dB from 10 to 20 dB. Maximum reflection coefficient is 0.07 (1.15 swr, 23.1 dB return loss).

### Specifications, 375A

HP Model	Frequency (GHz)	Power dissipation (watts)	Length		Flts waveguide size (in.)	Price
			(in.)	(mm)		
S375A	2.6 - 3.95	2.0	14 1/8	359	3 x 1 1/2	\$250
G375A	3.95 - 5.85	2.0	13	330	2 x 1	\$200
J375A	5.3 - 8.2	2.0	13	330	1 1/2 x 3/4	\$175
H375A	7.05 - 10.0	2.0	8 1/4	210	1 1/4 x 3/8	\$150
X375A	8.2 - 12.4	2.0	7-3/16	183	1 x 1/2	\$110
P375A	12.4 - 18.0	1.0	7 1/4	184	.702 x .391	\$135
K375A*	18.0 - 26.5	0.5	4 1/2	114	1/2 x 1/4	\$200
R375A*	26.5 - 40.0	0.5	4 3/8	111	.360 x .220	\$225

\*Circular flange adapters: K-band (UG-425/U) 11515A, \$35 each; R-band (UG-381/U) 11516A, \$40 each.



# MICROWAVE POWER MEASUREMENT



## POWER

The term "power" is used to describe the rate at which energy is made available to do work. In the field of microwave, this "work" is usually the transmission of aural, visual, or coded (radar) intelligence over a given distance. Other examples of work accomplished by microwave power include the excitation of molecules in a medium to produce heat, or the acceleration of particles for nuclear studies.

Voltage and current measurements are basic at low frequencies and dc because they can be made conveniently with high accuracy. Voltage, current, and resistance are fundamental electrical standards, whereas power is a derived term of necessarily lower accuracy. At low frequencies power may be calculated from voltage and impedance measurements using Ohm's law.

Two types of power measurement are common in microwave work. Many applications require a knowledge of average power in a device while others require peak power of a periodic pulse.

The *average power* over a given time period is the integral or summation of all instantaneous values of power during the period divided by the period. With a CW source, the shortest time of interest is generally the period of one cycle of output signal. The average power in this period is the same as for any integral number of cycles, provided steady-state conditions exist.

*Peak pulse power* may be defined several ways. The earliest common definition was: Peak pulse power is the average power during the time the pulse is on. It should be noted that any aberrations in the pulse, such as overshoot or ringing, are averaged out by this definition and the *instantaneous* peak power of the pulse cannot be considered as the peak pulse power. Early radar applications of pulsed microwave power involved only the use of rectangular pulses. In this case, this definition of peak pulse power was entirely adequate.

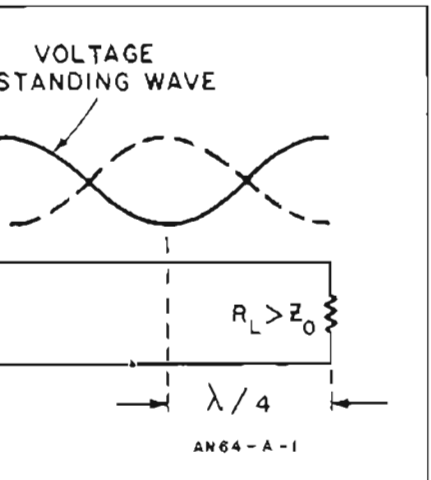

Figure 1. Mismatched transmission line exhibits standing waves, making voltage or current measurements arbitrary. At microwave frequencies, energy levels are more readily determined by power measurement which is independent of position (lossless line).

At microwave frequencies, we are faced with distributed circuit constants (Figure 1) and transmission line lengths that are appreciable fractions of a wavelength or more. Impedance at any given measurement point is not easily determined and any impedance mismatch between source and load sets up standing waves along the transmission line such that voltage measurement becomes arbitrary. Figure 1 illustrates how voltage and current vary on a mismatched line. Since the power remains invariant with position in a lossless line, the practical method of determining energy available in a microwave circuit becomes one of

power measurement which is independent of position (lossless line).

Continued development of microwave applications and accuracy improvement has required better definitions since many times the pulse is intentionally not rectangular, or contains aberrations which make it difficult to accurately determine the pulse width. In applications involv-

ing non-rectangular pulse shapes, peak pulse power may be defined as:

$$P_{pk} = \frac{e_p^2}{R}$$

where  $e_p$  is the peak *rms* voltage across the load resistance,  $R$ , absorbing the power. This expression accurately determines the maximum amplitude point of the pulse, and is especially useful for voltage breakdown checks. Since peak pulse power may have different meanings depending on the application, the method of measurement should be flexible enough to allow a choice as to what is considered to be the peak power of the pulse. Such methods are discussed in Application Note 64.

A great many microwave power measurements are well below 10 milliwatts where signal generators supply test signals for checking receiver, small-signal amplifier and detector performance. In some cases the power level may be on the order of only a few microwatts, requiring high sensitivity and stability in the measuring equipment.

### Bolometric power meters

Below 10 milliwatts, power is usually measured with bolometers (temperature-sensitive resistive elements) in conjunction with a balanced bridge. There are two general types of bolometers: thermistors, whose resistance decreases with temperature (negative temperature coefficient), and barretters which have a positive temperature coefficient. The use of thermistors is more prevalent because they are more rugged, both physically and electrically, than barretters. These tiny bolometer elements are mounted in devices that ideally present a perfect impedance match to microwave transmission lines, either coaxial or waveguide. Such devices are appropriately termed bolometer mounts and allow a "bias" connection to the bolometer element, as well as a proper entry point for rf. The bolometer is connected as one leg of a Wheatstone bridge (or modification thereof) through the bias connection, and bridge excitation is applied. The dc or low-frequency ac bridge excitation serves as the bolometer element bias power which affects the bolometer's resistance, so that the bridge is essentially balanced. When the unknown microwave power is applied to the bolometer, the resulting temperature rise causes the element's re-

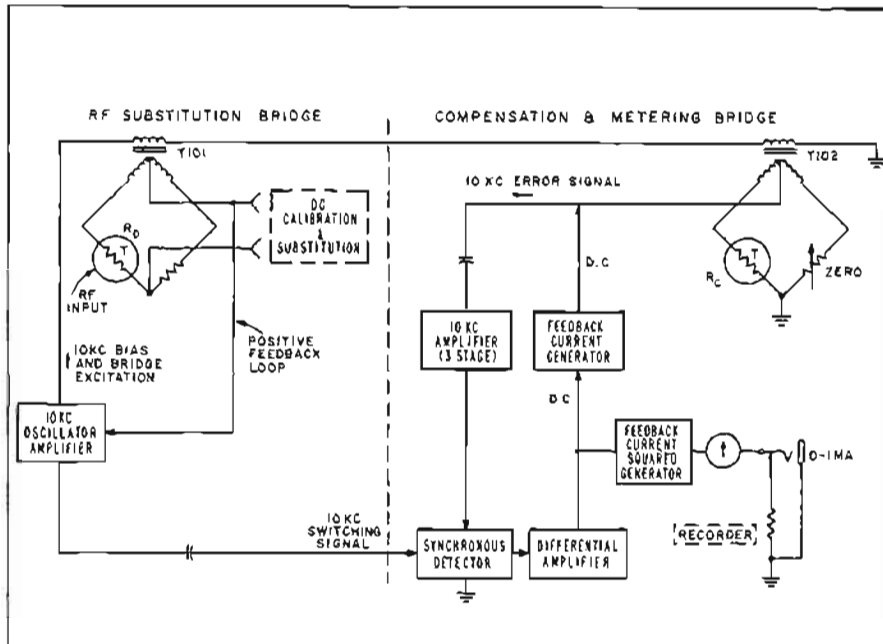

Figure 2. Block diagram of HP 431C Power Meter. Dual bridge provides proper bias to thermistor mount to correct for temperature variation and reduce zero drift.

sistance to change, tending to unbalance the bridge. By withdrawing a like amount of dc or ac bias power from the element, the bridge may be returned to balance, and the amount of bias power removed can be measured and displayed on an indicating meter.

### Automatic bolometer bridges

There are a number of bolometer bridge designs which provide various degrees of accuracy, speed, and convenience.

The Hewlett-Packard Model 431C Power Meter is a temperature-compensated, automatically balanced thermistor bridge of versatile design. Operating with any of the HP temperature-compensated thermistor mounts, the 431C automatically maintains bridge balance and reads substituted bias power to a basic accuracy of  $\pm 1\%$  of full scale. The 431C power ranges of 10 microwatts to 10 milliwatts (full scale) encompass virtually all levels involved in small signal microwave power testing.

Since all bolometer elements are temperature-sensing devices, they are, in themselves, unable to distinguish between applied power level changes and environmental temperature changes. As bolometer bridge sensitivity is increased, even minute temperature variations appear as though a varying power were being ap-

plied to the bolometer element. The result, if not compensated for, is "zero drift" of the power meter and erroneous power measurements.

A dual bridge arrangement, as shown in Figure 2, is used in the 431C to compensate for variations in temperature at the thermistor mount. The thermistor mounts used with the 431C have two thermistor elements. The two are in close thermal proximity and are affected equally by changes in ambient temperature. Thus  $R_0$ , responds to both ambient temperature and applied RF power;  $R_c$ , isolated from the RF power, responds only to ambient temperature. Each element is connected to its own bridge circuit in the power meter, which automatically controls bias power. This arrangement compensates for temperature changes, thus reducing zero drift in the 431C by a factor of 100 over uncompensated meters. Another advantage of the 431C design is that when zeroed on the most sensitive range, the meter may be switched to any other power range without re-zeroing (zero-carryover is within 1% on all ranges). The 431C also provides a dc output proportional to the deflection of its meter, an output useful for recording purposes or control of external circuits. This feature is extremely valuable for power meter leveling of microwave sweep oscillators and signal generators.

Thermistor mounts designed specifically for the 431C include the 478A, Coaxial Mount and 486A Waveguide Series. The coaxial unit operates from 10 MHz to 10 GHz; the waveguide units collectively cover waveguide bands from 2.6 to 40 GHz. All mounts present low swr over their frequency ranges without tuning.

### Non-temperature-compensated bridges

Also available is the HP Model 430C Power Meter, which operates with a number of non-temperature-compensated barretter or thermistor mounts such as the HP 477B Coaxial and 487 Waveguide Series. The 478A and 486A Thermistor Mounts also can be operated in a non-temperature-compensated mode with the 430C using the 11528A Adapter. This permits utilization of the 430C Power Meter in waveguide bands not covered by the 487 series of mounts. Accuracy of the 430C in measuring substituted power is  $\pm 5\%$  of full scale. (See page 381 for full specifications on 430C.)

### Calorimetric power meters

Bolometer elements cannot be used for direct power measurement at levels above 10 to 50 milliwatts because of their physical size. Calibrated directional couplers or attenuators are sometimes used to reduce the power level to the bolometer's range; however, this also reduces overall accuracy because of the additional tolerances on coupling factor or attenuator calibration. Where better accuracy is desired, calorimetric techniques provide a more useful result.

Calorimetric power meters dissipate the unknown power in a resistive termination which ideally is matched to the transmission line or source impedance. The temperature rise caused by the power dissipation is then measured by a temperature sensor which is calibrated against known amounts of dc power. Calorimetric power meters fall into two categories—dry and fluid. Dry calorimeters depend upon a static thermal path between the dissipative load and the temperature sensor. This arrangement often requires several minutes for the termination and sensor to reach equilibrium, making measurements time-consuming and too sluggish for tuning circuit parameters for optimum output.

Fluid calorimeters such as the HP 434A utilize a moving stream of oil to transfer heat quickly to the sensing element. An amplifier-feedback arrangement, in conjunction with the series oil flow system as shown in Figure 3, reduces measurement time in the 434A to less than 5 seconds for full-scale response. The physical size of the termination and the flow rate of liquid passing over the termination are primary factors which determine the maximum power that may be dissipated by a fluid calorimeter. The HP 434A covers the important range of 10 mW to 10 watts, where medium-power TWT's, klystrons, and low-power magnetrons produce power levels above the bolometer's range, and too low for large calorimetric systems. Further information on the 434A Calorimetric Power Meter is on page 383.

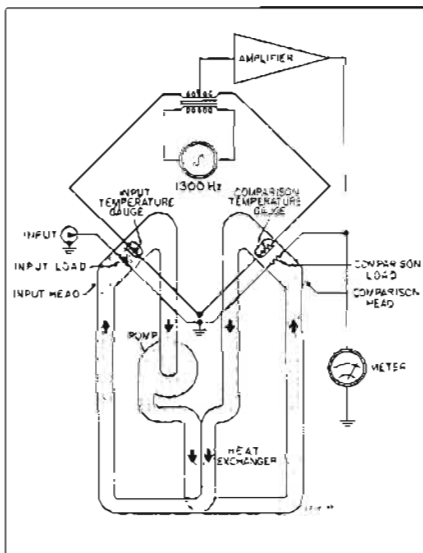

Figure 3. Simplified diagram of HP 434A Calorimetric Power Meter, showing oil flow path.

### Peak power measurement

A frequent requirement in microwave work is the measurement of peak power in a periodic pulse. This may be done by various indirect techniques using bolometers or calorimeters. Hewlett-Packard produces a versatile instrument that conveniently measures peak power directly in the 50 MHz to 2 GHz region. This instrument (the 8900B) utilizes a video comparator technique to bring a known dc voltage, supplied by the 8900B, in a known impedance to a level which is equal to the pulse being measured. This allows simple measurements of peak pulse power with a basic accuracy of 1.5 dB even when the waveform is not rectangular. A two-stage emitter follower in the instrument provides an isolated monitor output for viewing and analyzing the demodulated output on an externally connected oscilloscope. The output bandwidth is 1 kHz to 7 MHz

permitting useful reproduction of a variety of waveforms. This output may also be used for synchronizing the oscilloscope sweep circuitry. The optional custom calibration chart increases accuracy to 0.6 dB for critical applications. (See page 382 for more information on the 8900B.)

### Application Note 64

Complete information on the theory and operation of bolometers and bridges, along with other types of power meters, is included in a comprehensive application note available from Hewlett-Packard. Application Note 64 contains up-to-date information on virtually all aspects of microwave power measurement, including detailed descriptions and illustrations of instruments, techniques, error analysis and applications. Sources of measurement error and systematic methods for error-reduction allow selection of the best procedure for a specific application. Application Note 64, entitled "Microwave Power Measurement", is available on request through your HP sales office.

### Steps toward better accuracy

The fundamental standards of microwave power lie in dc or low-frequency ac voltage and resistance standards which may be accurately measured and used for comparison or substitution. Other factors, such as impedance matching and efficiency of the sensing device, play an important role in the overall measurement accuracy.

The basic accuracy of HP power measuring equipment satisfies the requirements of most applications without complicated set-ups requiring extensive manual operations and calculation. Certain other applications, however, demand varying degrees of accuracy improvement. The versatility and stability of HP equipment allows easy enhancement of its basic accuracy in a step-by-step manner until the degree of accuracy needed is achieved.

**Tuners:** Certainly one of the most important steps for higher accuracy is the elimination of mismatch loss with a tuner. Hewlett-Packard bolometer mounts and calorimeter input systems are designed and tested for good broadband impedance match (low swr) to common microwave transmission lines. However, source swr must also be considered in any power measurement, and the combination of source and load swr can produce serious mismatch errors. To eliminate mismatch error, HP 870A

Waveguide Series or 872A Coaxial Slide-screw Tuners may be used ahead of the bolometer or calorimeter input.

**Effective Efficiency and Calibration Factor:** A bolometric power meter can only measure power that is absorbed by the bolometer element, not that which is dissipated elsewhere in the mount or reflected by the mount (swr). Furthermore, the spatial distribution of current and resistance within the element is slightly different for microwave frequencies and the dc (or low-frequency ac) which is actually measured by the meter. The effects of these sources of error, generally unknown by the user, are measured at certain frequencies during the manufacture of the Models 478A and 486A mounts and presented on their nameplates as Calibration Factor and Effective Efficiency. Calibration Factor is the ratio of substituted bias power in the power meter to the microwave power incident on the mount. Effective Efficiency is the ratio of substituted bias power in the power meter to the microwave power absorbed by the mount. Although direct traceability to NBS (National Bureau of Standards) is not yet available in certain bands, the extensive tests and cross-checks conducted by HP on literally thousands of mounts assure a uniformly high level of efficiency in all mounts. (The HP E31-8690 Series of power calibration systems provides these data in either coax or waveguide--see page 380.) In addition, the mounts are swept-frequency tested, so the effects of even sharp resonances on efficiency are revealed and eliminated.

**Instrumentation:** HP 431C power meters provide a basic accuracy of  $\pm 1\%$  in substituted power to the thermistor. A dc input on the rear panel allows external dc substitution for increased accuracy when required. The HP 8402B Power Meter Calibrator may be connected to the dc substitution jack on the 431C to reduce instrumentation error to  $\pm 0.16\%$ . The DVM output of the HP 431C allows connection of a digital voltmeter (such as the HP 3440A, pages 220-221) for high precision readout of power.

The 434A Calorimetric Power Meter basic accuracy is  $\pm 5\%$  of full scale, which includes both instrumentation error and efficiency. The built-in calibration source provides a 0.1 watt dc check point accurate to 1% for convenient verification of the 434A calibration. The instrumentation uncertainty can be substantially reduced by calibrating the 434A on the range to be used with an external dc test set. The HP K02-434A DC Test Set provides calibration power levels in convenient steps from 2 mW to 10 W, and is accurate to  $\pm 0.5\%$  of output.



## METER; THERMISTOR MOUNTS

Accurate power measurements, 10 MHz to 40 GHz  
Models 431C, 478A, 486A

The Model 431C Power Meter, together with its companion 478A, and 486A Thermistor Mounts, enables you to make even routine microwave power measurements with standards-lab accuracy. You have complete confidence in the accuracy of your measurements because all sources of error are taken into consideration. Thermistor mount efficiency, stated as both Effective Efficiency and Calibration Factor,\* is furnished with each 478A and 486A Thermistor Mount, and the 431C itself affords high instrumentation accuracy (better than 1% of full scale on most ranges)—thus the characteristics of the measurement system are known from thermistor mount input to power meter readout.

Thermistor mount efficiency plays a very significant role in determining overall measurement accuracy, and the 431C provides real convenience for utilization of the efficiency data imprinted on each mount. The 431C contains a front panel Calibration Factor control, calibrated in 1% steps from 100% to 88%, which normalizes the meter reading to account for the efficiency correction factor of the mount. Simply set the control and read the meter; no calculations are required.

The 431C provides full scale readings from 10 microwatts to 10 milliwatts in seven ranges; range switching is in 5-dB steps. The meter movement is calibrated in milliwatts and dBm. The accuracy of the 431C is maintained even in the presence of high intensity fields, for the instrument exhibits very low rf susceptibility. In fact, the 431C surpasses all the requirements of MIL-I-6181D.

Two self-balancing bridges (of which the thermistor mount forms a part) are used in the power measuring system of the 431C. One bridge senses the rf power; the other corrects the meter reading for ambient temperature changes. The result is very high stability, eliminating the need to continually check and reset the zero adjustment. In addition, a single zero adjustment holds for all ranges, simplifying measurements where it is inconvenient to turn off the power source during range changes.

Provision is also incorporated in the 431C for further refinement of instrument accuracy and resolution. A Voltmeter Output allows use of appropriate digital or differential dc voltmeter for increased resolution of the meter indication. In addition, a dc calibration input jack permits precise dc calibration of the instrument and thermistor mount (see HP 8402B).

### Specifications, 431C

**Instrument type:** automatic, self-balancing power meter for use with temperature-compensated thermistor mounts.

**Power range:** 7 ranges with full-scale readings of 10, 30, 100, and 300  $\mu$ W, 1, 3, and 10 mW; also calibrated in dBm from -20 dBm to +10 dBm full scale in 5-dB steps.

**Accuracy:** +20°C to +35°C:  $\pm 1\%$  of full scale (100  $\mu$ W range and above);  $\pm 1.5\%$  of full scale (30  $\mu$ W range);  $\pm 2\%$  of full scale (10  $\mu$ W range).  
0°C to +55°C:  $\pm 3\%$  of full scale on all ranges.

\*Calibration Factor and Effective Efficiency. "Figures of merit" that express the ratio of the substituted audio signal measured by the power meter to the microwave power incident on and absorbed by the mount, respectively.

**Calibration factor control:** 13 position switch normalizes meter reading to account for thermistor mount Calibration Factor (or Effective Efficiency). Range: 100% to 88% in 1% steps.

**Thermistor mount:** external temperature-compensated thermistor mounts required for operation.

**Meter movement:** taut-band suspension, individually calibrated mirror-backed scales; milliwatt scale greater than  $4\frac{1}{4}$  in. (108 mm) long.

**Zero carryover:** less than 1% of full scale when zeroed on most sensitive range.

**Zero balance:** continuous control about zero point; range below zero is equivalent to at least 2% of full scale.

**DVM output:** 1,000 V into open circuit corresponds to full-scale meter deflection (1.0 on 0-1 scale)  $\pm 0.5\%$ ; 1 k $\Omega$  output impedance, BNC female connector; effect of loading impedance less than 10 M $\Omega$  must be accounted for.

**Recorder/leveler output:** with load impedance of 600  $\Omega$  or more, output is approximately 1 V dc at full scale meter deflection; BNC female connector.

**Calibration input:** binding posts for calibration of bridge with HP 8402B Power Meter Calibrator or precise dc standards.

**Power:** 115 or 230 V  $\pm 10\%$ , 50 to 400 Hz, 2 $\frac{1}{2}$  W; optional rechargeable battery provides up to 24 hours continuous operation.

**RFI:** meets all conditions specified in MIL-I-6181D.

**Dimensions:** 7 $\frac{3}{4}$  in. wide, 6 $\frac{1}{2}$  in. high, 11 in. deep from panel (197 x 165 x 279).

**Weight:** net, 7 lbs (3,2 kg), 9 lbs (4,1 kg) with battery; shipping, 11 lbs (5 kg), 13 lbs (6,3 kg) with battery.

**Furnished:** 5-ft (1520 mm) cable for HP temperature compensated thermistor mounts; 7 $\frac{1}{2}$  ft. (2290 mm) power cable, NEMA plug.

**Available:** 00415-606 Rechargeable Battery Pack for field installation, \$100.

**Price:** Model 431C, \$475.

#### Options:

01. Rechargeable battery installed, provides up to 24 hours continuous operation, add \$100.
02. Rear input connector wired in parallel with front panel input connector, add \$15.
09. With 10-foot (3050 mm) cable for 100  $\Omega$  or 200  $\Omega$  mount, add \$25.
10. With 20-foot (6100 mm) cable for 100  $\Omega$  or 200  $\Omega$  mount, add \$50.
11. With 50-foot (15240 mm) cable for 100  $\Omega$  mount, add \$100.
12. With 100-foot (30480 mm) cable for 100  $\Omega$  mount, add \$150.
13. With 200-foot (60960 mm) cable for 100  $\Omega$  mount, add \$250.
21. With 50-foot (15240 mm) cable for 200  $\Omega$  mount, add \$100.
22. With 100-foot (30480 mm) cable for 200  $\Omega$  mount, add \$150.
23. With 200-foot (60960 mm) cable for 200 $\Omega$  mount, add \$250.

### 478A, and 486A Thermistor Mounts

These thermistor mounts are designed for use with HP 431C Power Meter. Each is supplied with Calibration Factor and Effective Efficiency Data,\* permitting power measurements to be made with absolute accuracy. The data, provided at several points across each band, are traceable to the National Bureau of Standards to the extent allowed by the Bureau's facilities. Thus, mount losses and reflections (that part of the incident power which does not reach the power-sensing thermistor) can be accounted for under all measurement conditions.

The calibration data at points not yet on the NBS schedule are based on interim standards established at Hewlett-Packard after years of designing, manufacturing, and testing thermistor mounts. Literally thousands of test and measurements have gone into the development of these standards, including cross-checks against NBS-calibrated mounts wherever possible. Thus efficiency data are provided at many points in addition to those on the NBS schedule to facilitate interpolation and help you to make more accurate power measurements more easily. For easy access, these data are affixed directly to each mount.

Both Calibration Factor and Effective Efficiency Data are furnished to provide complete measurement flexibility. Calibration Factor is used as the correction factor for general applications when a tuner is not used; Effective Efficiency is used whenever a tuner is part of the measurement system.

These thermistor mounts are temperature compensated for low drift, permitting measurement of microwave power as low as one microwatt. Each mount contains a pair of thermistor sets in similar thermal environments. One set responds to the RF input and ambient temperature; the other responds just to the ambient temperature to compensate for temperature changes.

Model 478A is designed for 50-ohm coaxial systems. It operates over frequencies from 10 MHz to 10 GHz presenting a good 50-ohm match over its frequency range, and no tuning is required.

Model 486A mounts are designed for 2.6 to 40 GHz waveguide systems. Each mount provides a good match over its waveguide range; no tuning is required.

The subject of power measurements is covered in detail in Hewlett-Packard Application Note 64, "Microwave Power Measurement." This comprehensive Note discusses principles of operation, techniques of measurement, interpretation of results, and accuracy considerations. Application Note 64 is available upon request from any Hewlett-Packard Field Office.

### Specifications

HP Model <sup>1</sup>	Frequency range, GHz	Maximum swr	Operating resistance (ohms)	Price
478A	10 MHz to 10 GHz	1.75, 10 to 25 MHz 1.3, 25 MHz to 7 GHz 1.5, to 10 GHz	200	\$155
S486A	2.60 to 3.95	1.35	100	\$195
G486A	3.95 to 5.85	1.5	100	\$180
J486A	5.30 to 8.20	1.5	100	\$170
H486A	7.05 to 10.0	1.5	100	\$165
X486A	8.20 to 1.24	1.5	100	\$145
M486A	10.0 to 15.0	1.5	100	\$195
P486A	12.4 to 18.0	1.5	100	\$195
K486A <sup>2</sup>	18.0 to 26.5	2.0	200	\$300
R486A <sup>2</sup>	26.5 to 40.0	2.0	200	\$375

<sup>1</sup> 11528A Adapter adapts mounts to 430 Series Power Meter (thermistor circuit unbalanced, no temperature compensation), \$10.

<sup>2</sup> Circular flange adapters- K-band (UG-425/U) HP 11515A, \$35 each; R-band (UG-381/U) HP 11516A, \$40 each.

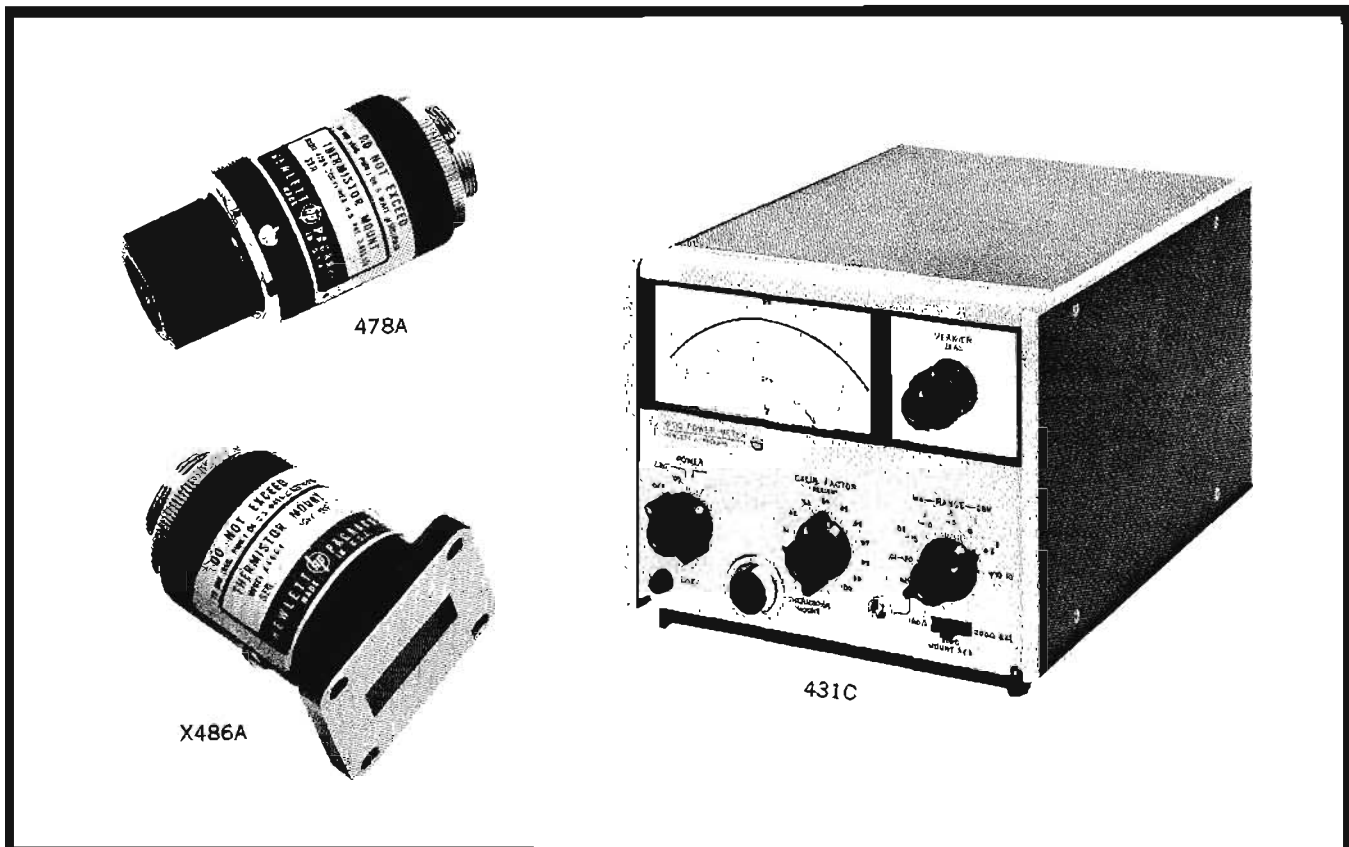

**POWER****METER, MOUNT CALIBRATORS**

Increase power measurement accuracy

Model 8402B; E31-8690A systems

**8402B Power Meter Calibrator**

Full-scale calibration and meter tracking of HP 431 Power Meters can be verified with the 8402B. In addition, the Power Meter Calibrator can be used to determine operating resistance of the thermistors in the thermistor mount used with a particular 431 and to improve on the basic accuracy of the 431 Power Meter with the dc substitution technique.

**Specifications, 8402B****Calibration function**

**Calibration points:** output currents corresponding to 0.01, 0.03, 0.1, 0.3, 1.0, 3.0, 10.0, 30.0, 60.0, 4.0, and 2.0 mW.

**Calibration current uncertainty:**  $\pm 0.05\%$ , +20 to +30°C;  $\pm 0.2\%$ , 0 to +55°C.

**Power meter calibration uncertainty:** 2 x current uncertainty + thermistor operating resistance uncertainty ( $\pm 0.16\%$ , +20 to +30°C;  $\pm 0.46\%$ , 0 to +55°C).

**Thermistor operating resistance function**

**Resistance center values:** 100 and 200 ohms.

**Range:**  $\pm 0.5\%$  about center values in 0.1% steps.

**Uncertainty:**  $\pm 0.06\%$ .

**DC substitution function**

**Range:** 1  $\mu$ W to 10 mW (precision differential or digital voltmeter required—voltmeter input resistance  $\geq 10$  megohms required for negligible loading effect).

**Uncertainty:**  $\pm (0.06\% + \text{thermistor operating resistance uncertainty} + 2 \times \text{voltmeter uncertainty})$ , 0 to +55°C.

**General**

**RFI:** meets all conditions specified in MIL-I-6181D.

**Power:** 115 or 230 V  $\pm 10\%$ , 50 to 400 Hz, approximately 3 W.

**Dimensions:** 7 $\frac{3}{4}$ " wide, 6 $\frac{1}{2}$ " high, 11" deep from panel (197 x 165 x 279 mm).

**Weight:** net 6 $\frac{1}{2}$  lbs (2.9 kg); shipping 9 lbs (4.1 kg).

**Price:** HP 8402B, \$475.

**Thermistor mount calibration systems**

For accurate power measurements, thermistor mount elements used with power meter bridges must be calibrated for either Effective Efficiency or Calibration Factor. Hewlett-Packard offers a series of systems which make such measurements possible on a swept or stepped frequency basis with high transfer accuracy. The system is furnished with one or more thermistor mounts which are calibrated by the HP Standards Laboratory at six frequencies across the band of interest. Traceability to NBS is furnished wherever currently available. Calibration is achieved by normalizing the readout device to the reference mount so that the readout is directly in percentage Calibration Factor or Effective Efficiency. Two types of readout are available: a digital voltmeter which is programmed to display values at the six calibrated frequencies, and an X-Y recorder which gives a continuous presentation across the band. Mounts thus calibrated can then be used to advantage with the HP 431C which has a front-panel control to normalize the meter reading to account for the correction factor of the mount.

The Power Calibration System consists of two subsystems. One is the frequency-independent E31-8690A. The other is one or more of the E30-8691B through E31-8697A frequency-dependent subsystem. A total of twelve frequency-dependent subsystems are available which collectively cover the range from 1 to 40 GHz. For further information, contact the nearest Hewlett-Packard Sales Office.

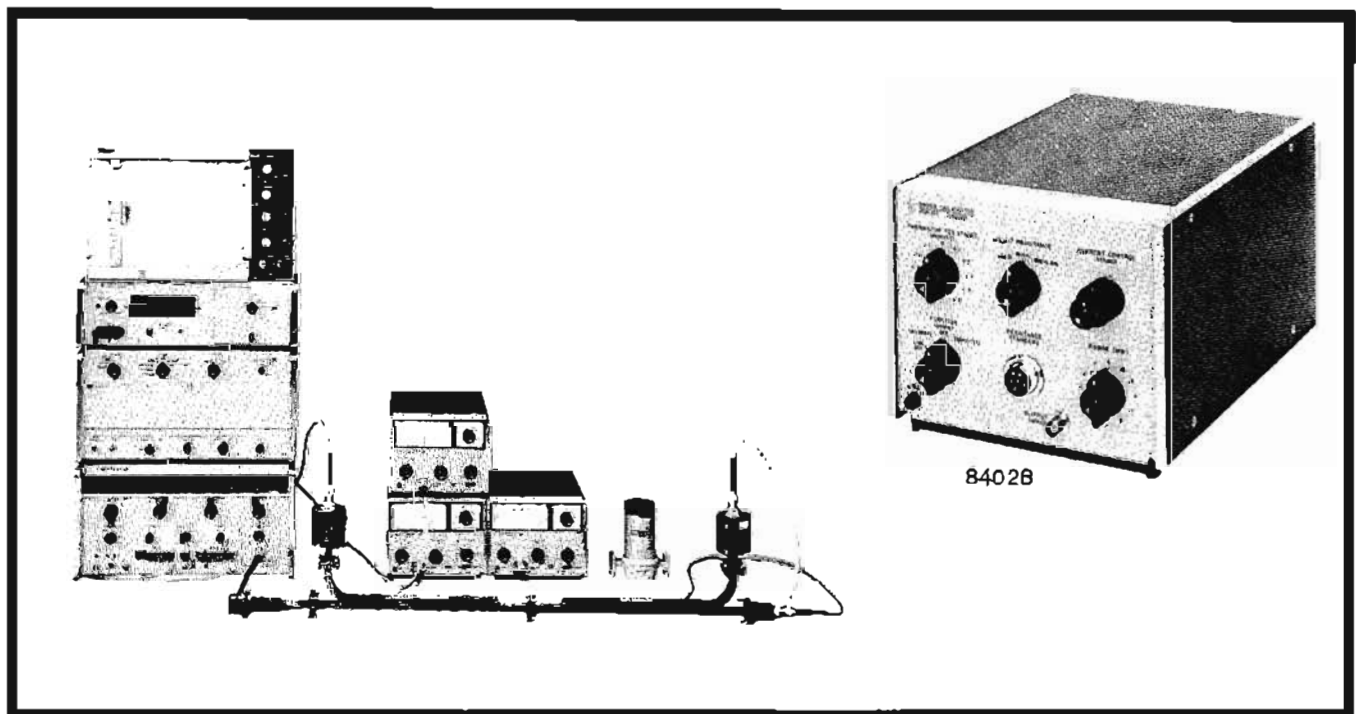

## MICROWAVE POWER METER

Reads directly in mW and dBm, 0.01 to 10mW  
Models 430C; 477B, 487 Thermistor Mounts



POWER

The HP 430C reads rf power directly in dBm or mW—and completely eliminates tedious computation and troublesome adjustments during operation. The instrument may be used at any frequency for which there are bolometer mounts—and measurements are entirely automatic.

In measuring power, HP 430C uses a bolometer at either 100- or 200-ohm levels. Power is read directly in milliwatts, 0.01 to 10 mW, or in dBm from -20 to +10. Higher powers may be measured by adding attenuators to the system. Directional couplers also may be used to sample energy.

When used in an appropriate bolometer mount, instrument fuses are generally satisfactory for measuring power at frequencies up to 4 GHz. Barretters and thermistors can be used for measurements at much higher frequencies, up to 12.4 GHz for barretters (in HP mounts) and up to 40 GHz for certain thermistors.

Hewlett-Packard waveguide bolometer mounts for the 430C are available covering, collectively, the frequency spectrum from 2.6 to 40 GHz. In addition, Model 477B Thermistor Mount covers the frequency spectrum from 10 MHz to 10 GHz.

### Specifications, 430C

**Power range:** 5 ranges, front-panel selector; full-scale readings of 0.1, 0.3, 1, 3, and 10 mW; also continuous readings from -20 to +10 dBm.

**External bolometer:** frequency range depends on bolometer mount; bolometers can operate at resistance levels of 100 or 200 ohms and can have positive or negative temperature coefficients; any dc bias current up to 16 mA is available for biasing bolometers; dc bias current is continuously adjustable and independent of bolometer resistance and power level range.

**Accuracy:**  $\pm 5\%$  of full scale.

**Power:** 115 or 235 V  $\pm 10\%$ , 50 to 400 Hz, 90 W.

**Dimensions:** cabinet: 7 $\frac{1}{2}$ " wide, 11 $\frac{1}{2}$ " high, 14 $\frac{1}{4}$ " deep (191 x 292 x 362 mm); rack mount: 19" wide, 7" high, 13 $\frac{1}{8}$ " deep behind panel (483 x 178 x 333 mm).

**Weight:** net 14 lbs (6.3 kg), shipping 16 lbs (7.2 kg) (cabinet); net 18 lbs (8.1 kg); shipping 27 lbs (12.2 kg) (rack mount).

**Accessory Available:** 11528A Adapter, adapts HP 478A, 486A, 8478B Thermistor Mounts for use with 430C, \$10.

**Price:** HP 430C, \$295 (cabinet); HP 430CR, \$300 (rack mount).

### 477B Thermistor Mount

This coaxial thermistor mount, designed for use in 50-ohm systems with the HP 430C, covers 10 MHz to 10 GHz with an swr of less than 1.5. It requires no tuning and employs long-time-constant elements that assure measurement accuracy—even for low duty cycle pulses. In addition, it is not susceptible to burnout even at 1 watt peak.

### Specifications, 477B

**Frequency range:** 10 MHz to 10 GHz.

**Reflection Coefficient:** full range,  $< 0.2$  (1.5 swr, 14 dB return loss); 50 MHz to 7 GHz,  $< 0.13$  (1.3 swr, 17.7 dB return loss).

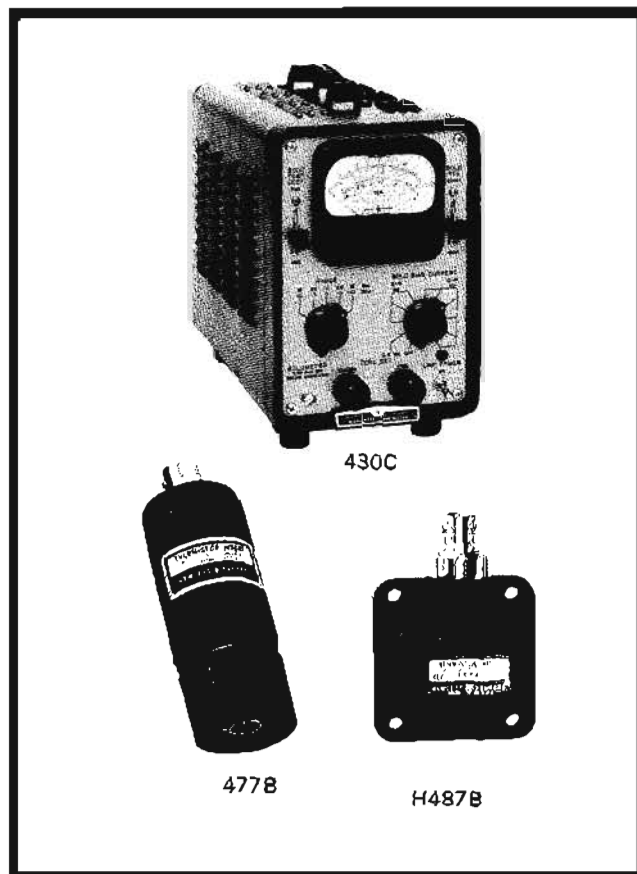

**Power range:** 0.01 to 10 mW (with HP 430C).

**Element:** 200-ohm, negative temperature coefficient thermistor included; approx. 13 mA bias required.

**RF connector:** Type N male.

**Price:** HP 477B, \$75.

### 487 Waveguide Thermistor Mounts

Hewlett-Packard Series 487 instruments, for use with HP 430C Power Meters, collectively cover frequencies from 5.3 to 18 GHz. Each 487 series mount covers the full frequency range of its waveguide band and requires no tuning. The long time constant of the mount makes it ideal for measuring average power of low duty cycle pulses. Burnouts are virtually impossible. All models may be used to measure a maximum average power of 10 mW.

### Specifications, 487

HP Model	Maximum swr	Frequency range* GHz	Price
J487B	1.5	5.3 - 8.2	\$ 90
H487B	1.5	7.05 - 10.0	\$ 80
X487B	1.5	8.2 - 12.4	\$ 75
P487B	1.5	12.4 - 18.0	\$110

\*HP 486A Waveguide Thermistor Mounts are available in S- through R-band (2.6 to 40 GHz); 11528A Adapter required.





## PEAK POWER CALIBRATOR

Power measurements, 50 to 2000 MHz, to  $\pm 0.6$  dB  
Model 8900B

### Features

- Measures true peak power  $\pm 0.6$  dB absolute
- Measurement completely independent of repetition rate and pulse width ( $> 0.25 \mu\text{sec}$ )
- Readily standardized against external bolometer or calorimeter
- Incorporates wide-band (7 MHz) detector output for pulse monitoring

The HP 8900B Peak Power Calibrator provides a convenient means for measuring the peak rf power of pulses in the range from 50 to 2000 MHz. The power level is read out directly on the panel meter and is completely independent of repetition rate and pulse width ( $> 0.25 \mu\text{sec}$ ). The instrument consists basically of a precision terminated input circuit, diode detector, dc reference supply, meter and a chopped video output system.

In operation, the rf signal is applied to the input circuit, which, through a power splitter, feeds the diode detector. The demodulated diode output and the output of the dc reference supply are simultaneously fed to the video output through a mechanical chopper. In making a measurement, a suitable external oscilloscope is connected to the video output, and the dc reference voltage is adjusted so that it is exactly equal to the peak value of the demodulated pulse.

### Panel meter readout

The level of the required dc reference voltage is then indicated on the panel meter, calibrated to read peak rf power. The diode is operated in a biased condition for

maximum stability of calibration. Provision is made, however, for readily standardizing the instrument against an external bolometer or calorimeter by simply connecting to a rear-panel output in place of a standard termination.

### Specifications

#### Radio frequency measurement characteristics

**RF range:** 50 to 2000 MHz.

**RF power range:** 200 mW peak full scale (may be readily increased through use of external attenuators or directional couplers).

**RF power accuracy:**  $\pm 1.5$  dB ( $\pm 0.6$  dB with custom calibration curve).

**RF power precision:** 0.1 dB.

**RF pulse width:**  $> 0.25 \mu\text{sec}$ .

**RF repetition rate:** 1.5 MHz maximum.

**RF impedance:** 50 ohms.

**RF vswr:**  $< 1.25$ .

#### Monitor output

**Level:**  $> 0.2$  volt for 20 mW input (nominal).

**Impedance:** 150 ohms nominal.

**Bandwidth:**  $> 7$  MHz.

#### Physical characteristics

**Dimensions:**  $7\frac{3}{4}$ " wide,  $6\frac{1}{8}$ " high, 11" deep (197 x 156 x 279 mm).

**Weight:** net 10 lbs (4.5 kg); shipping 13 lbs (5.9 kg).

**Power:** 105 to 125 or 210 to 250 volts, 50 to 60 Hz.

**Price:** HP 8900B, \$485; custom calibration curve, \$75.

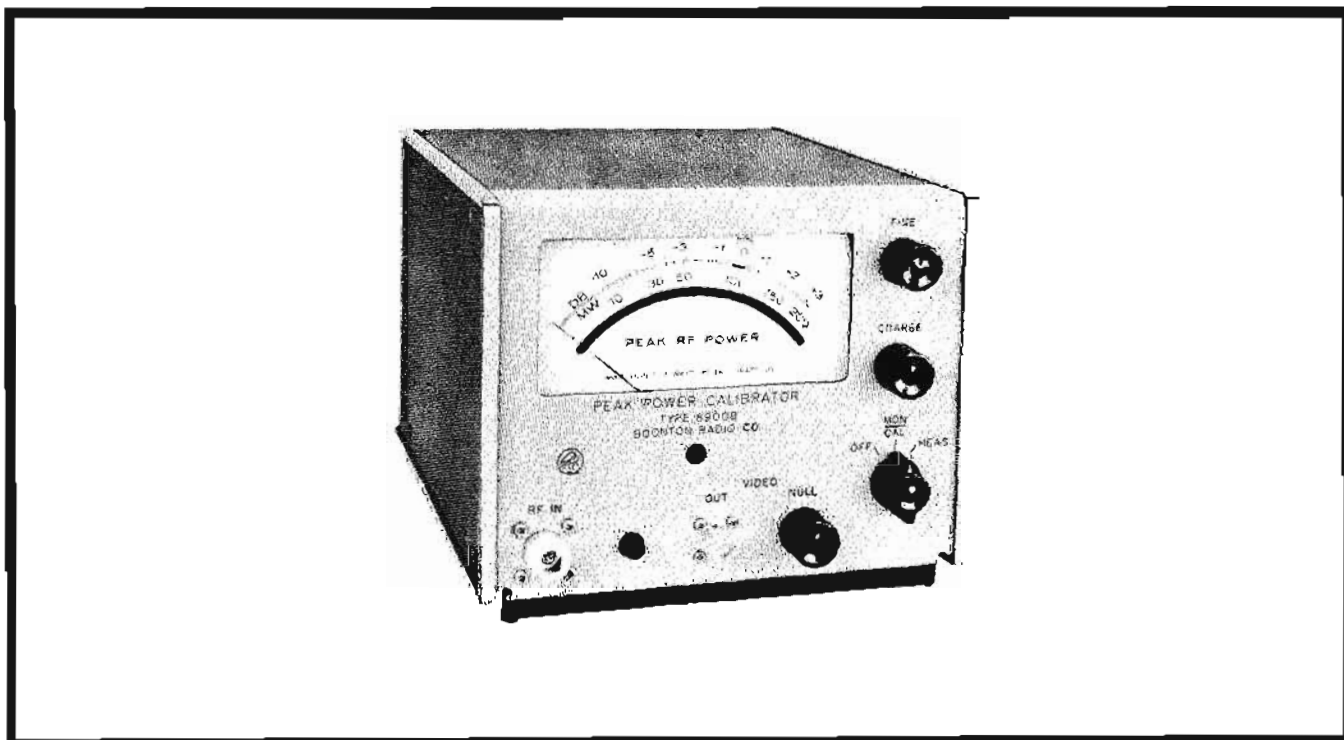

# CALORIMETRIC POWER METER

Just connect, read power 10 mW to 10 watts  
Model 434A



## POWER

With the 434A, measurement is literally as simple as connecting to a 50-ohm Type N front-panel terminal and reading power directly. The instrument has only two simple front-panel controls and is ideal for use by non-technical personnel.

Model 434A fills the important range between bolometer-type microwave power meters such as HP 431C and conventional calorimeters whose lower range is approximately 10 watts. But, unlike previous cumbersome and costly equipment suggested for its range, the HP 434A is completely self-contained and requires no external detectors. In addition, the wider frequency response permits the unit to be conveniently calibrated by the application of a known dc power.

### Rapid response time

Model 434A employs a self-balancing bridge and a high-efficiency heat transfer system to and from an oil stream to provide a full-scale response time of 5 seconds or less. This fast reaction, a fraction of the response time needed by ordinary calorimeters, means the 434A quickly follows small power changes, such as may be encountered in tuning.

Basically, the Model 434A consists of a self-balancing bridge which has identical temperature-sensitive resistors (gauges) in

two legs, an indicating meter and two load resistors, one for the unknown input power and one for the comparison power. The input load resistor and one gauge are in close thermal proximity so that heat generated in the input load resistor heats the gauge and unbalances the bridge. The unbalance signal is amplified and applied to the comparison load resistor which is in close thermal proximity to the other gauge so that the heat generated in the comparison load resistor is transferred to its gauge and nearly rebalances the bridge.

The meter measures the power supplied to the comparison load to rebalance the bridge. The characteristics of the gauges are the same, and the heat transfer characteristics from each load are the same, so the power dissipated in each load is the same, and the meter may be calibrated directly in input power.

The power measurement is accurate because the flow rates through the two heads are the same and the oil enters the heads at nearly the same temperature. To insure constant temperature and to bring the streams to nearly the same temperature, they are passed through a parallel-flow heat exchanger just prior to entering the heads. Identical flow rates are obtained by placing all elements of the oil system in series.

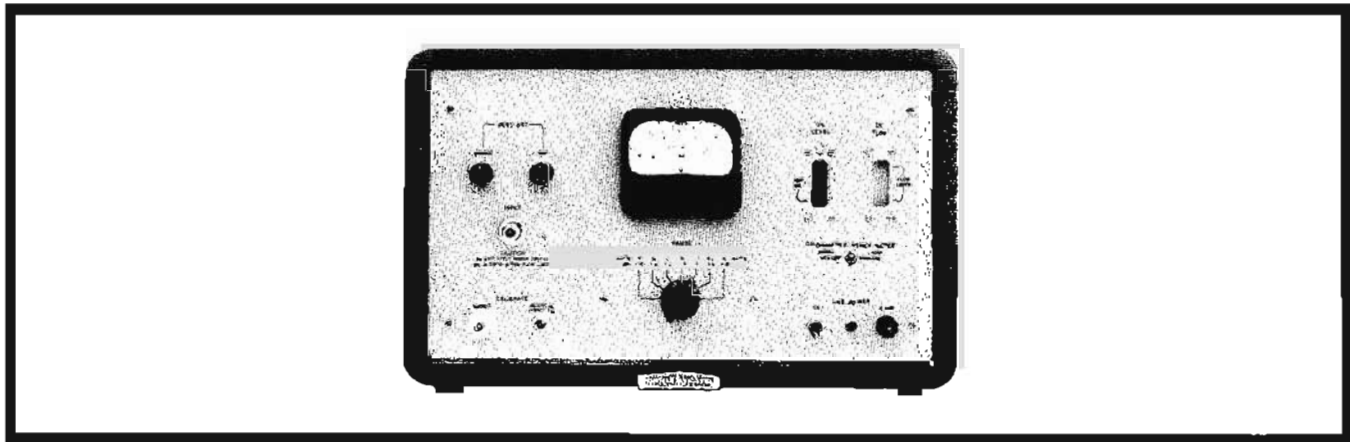

### Specifications

**Input power range:** seven meter ranges; full-scale readings of 0.01, 0.03, 0.1, 0.3, 1, 3 and 10 watts; meter scale also calibrated from -10 to 0 dBW, providing continuous readings from -30 to +10 dBW; power range can be extended upward with attenuators or directional couplers.

**Maximum input power:** 1 kW peak; 10 watts average.

**Frequency range:** dc to 12.4 GHz.

**Accuracy:** within  $\pm 5\%$  of full scale; includes dc calibration and rf termination efficiency but not mismatch loss; greater accuracy can be achieved through appropriate techniques.

#### Estimated attainable accuracy

	Upper ranges	Two lowest ranges
DC	0.5%	2%
0 to 1 GHz	1%	3%
1 to 4 GHz	2%	4%
4 to 10 GHz	3%	5%
10 to 12.4 GHz	4%	5%

**DC input resistance:** 50 ohms  $\pm 5$  ohms at Type N input jack.

**Reflection Coefficient:** dc to 5 GHz,  $< 0.13$  (1.3 swr, 17.7 dB return loss); 5 to 11 GHz,  $< 0.2$  (1.5 swr, 14 dB return loss); 11 to 12.4 GHz,  $< 0.26$  (1.7 swr, 11.7 dB return loss).

**Meter response time:** less than 5 seconds for full-scale deflection.

**Internal calibrator:** 100 mW dc  $\pm 1\%$  into 45 to 55 ohms.

**Power:** 115 or 230 volts  $\pm 10\%$ , 50 to 60 Hz approximately 180 watts with no input, 200 watts with 10 watts input.

**Dimensions:** cabinet: 20 $\frac{3}{4}$ " wide, 12 $\frac{3}{4}$ " high, 14" deep (527 x 324 x 356 mm); rack mount: 19" wide, 10-15/32" high, 13 $\frac{1}{2}$ " deep behind panel (483 x 266 x 343 mm).

**Weight:** net 49 lbs (22,1 kg), shipping 59 lbs (26,6 kg) (cabinet); net 43 lbs (19,4 kg), shipping 53 lbs (23,9 kg) (rack mount).

**Accessories available:** 281A,B Waveguide-to-Coax Adapters (see Coax-Waveguide); K02-434A DC Test Set (for more accurate power measurements), \$1000.

**Price:** HP 434A, \$1600 (cabinet); HP 434AR, \$1585 (rack mount).

## NOISE FIGURE



## NOISE FIGURE METERS; SOURCES

Automatic noise figure measurements to 18 GHz  
Models 340B, 342A; 343A, 345B, 347A, 349A

In microwave communications, radar, etc., the weakest signal that can be detected is usually determined by the amount of noise added by the receiving system. Thus, any decrease in the amount of noise generated in the receiving system will produce an increase in the output signal-to-noise ratio equivalent to a corresponding increase in received signal. From a performance standpoint, an increase in the signal-to-noise ratio by reducing the amount of noise in the receiver is more economical than increasing the power of the transmitter.

The quality of a receiver or amplifier is expressed in a figure of merit, or noise figure. Noise figure is the ratio, expressed in dB, of the actual output noise power of the device to the noise power which would be available if the device were perfect and merely amplified the thermal noise of the input termination

rather than contributing any noise of its own.

The Hewlett-Packard system of automatic noise figure measurement depends upon the periodic insertion of a known excess noise power at the input of the device under test. Subsequent detection of noise power results in a pulse train

of two power levels. The power ratio of these two levels contains the desired noise figure information. Hewlett-Packard noise figure meters automatically measure and present this ratio directly in dB of noise figure.

Noise figure is discussed in detail in Hewlett-Packard Application Note 57, which is available from your local Hewlett-Packard field office upon request. Application Note 57, "Noise Figure Primer," derives noise figure formulas, describes general noise figure measurements and discusses accuracy considerations. One of the measurement systems discussed in Application Note 57 is shown in Figure 1. The portion of the diagram within the dashed box is a simplified block diagram of the HP 340B and 342A Noise Figure Meters, and the excess noise source could be any of the noise sources described on these pages.

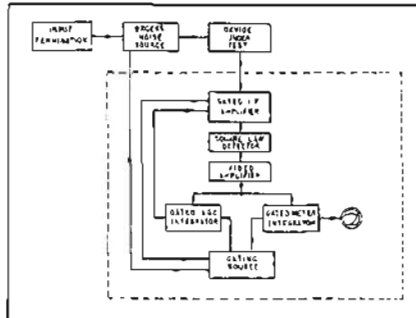

Figure 1. Automatic noise figure measurement system.

### Advantages:

- Reads noise figure directly in dB
- Completely automatic measurement
- Easily used by non-technical personnel
- No periodic recalibration needed
- Fast response; ideal for recorder operation

### Uses:

- Measure noise figure in microwave or radar receivers, rf and IF amplifiers
- Compare unknown noise sources against known noise levels
- Adjust parametric amplifiers for optimum noise figure

Receiver and component alignment jobs which once took skilled engineers a full hour are now done in 5 minutes by a semi-skilled worker. Receiver noise figure often can be improved over the best adjustment previously possible. For instance, a 3 dB improvement in receiver noise figure is equivalent to doubling transmitter output. Since accurate alignment is easy, equipment is better maintained and peak performance enjoyed regularly.

These are some of the time-saving, cost-cutting advantages of Hewlett-Packard noise figure measuring equipment, Models 340B and 342A, when used with coaxial and waveguide noise sources.

Model 340B Noise Figure Meter, when used with an HP noise source, automatically measures and continuously dis-

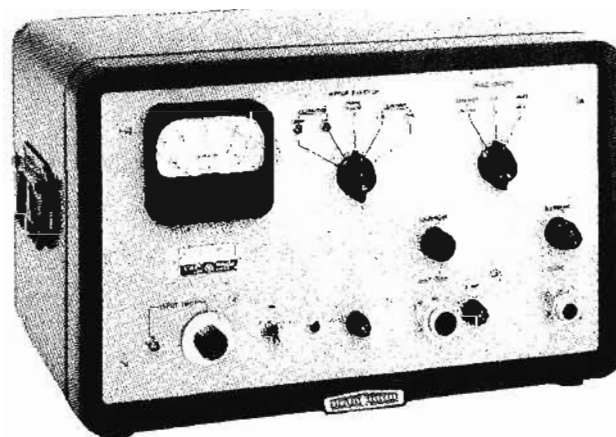

340B

plays the noise figure of IF or rf amplifiers tuned to 30 or 60 MHz and of radar or microwave receivers with intermediate frequencies of 30 and 60 MHz. Collectively, HP noise sources cover frequencies from 10 MHz to 18 GHz.

### Five-frequency operation

Model 342A Noise Figure Meter is similar to HP 340B, except that it operates on five frequencies between 30 and 200 MHz. Four of these frequencies are normally 60, 70, 105 and 200 MHz; the fifth is the basic 342A tuned amplifier frequency of 30 MHz.

In operation, a noise source, either a gas discharge tube or a diode, is connected to the input of a device under test. The IF amplifier output of the device is connected to the 340B or 342A. The noise figure meter gates the noise source on and off. When the source is on, the noise level is that of the device, plus the noise source. When the source is off, the noise level is that of the device and its termination. The noise figure meter automatically compares these two conditions and presents noise figure directly on a front-panel meter. Rate of response is such that changes in noise figure are constantly indicated on the meter.

### Noise sources

Hewlett-Packard 343A VHF Noise Source: Specifically for IF and rf amplifier noise measurement, a temperature-limited diode source with broadband noise output from 10 to 600 MHz with 50-ohm source impedance and low swr.

Hewlett-Packard 345B IF Noise Source: Operates at either 30 or 60 MHz, as selected by a switch; another selector permits matching 50-, 100-, 200-, and 400-ohm impedances.

Hewlett-Packard 347A Waveguide Noise Sources: Argon gas discharge tubes mounted in waveguide sections; for waveguide bands 2.6 through 18 GHz, they provide uniform noise throughout the range; maximum swr is 1.2.

Hewlett-Packard 349A UHF Noise Source: Argon gas discharge tubes in Type N coaxial configuration for automatic noise figure readings, 400 to 4000 MHz.

### Specifications, 340B and 342A

**Noise figure range:** 5.2 dB noise source, 0 to 15 dB, indication to infinity; 15.2 dB noise source, 3 to 30 dB, indication to infinity.

**Accuracy (excluding source accuracy):** noise diode scale:  $\pm 0.5$  dB, 0 to 15 dB; gas tube scale:  $\pm 0.5$  dB, 10 to 25 dB;  $\pm 1$  dB, 3 to 10 dB and 25 to 30 dB; (for stated accuracy with 343A S-, H-, X- and P347A and 349A Noise Sources, correction factor equal to the difference between specified excess noise and 15.2 dB must be applied to meter reading).

**Input frequency:** 340B; 30 or 60 MHz, selected by switch; 342A: 30, 60, 70, 105, and 200 MHz, selected by switch; other frequencies available.

**Bandwidth:** 1 MHz minimum.

**Input requirements:**  $-60$  to  $-10$  dBm (noise source on); corresponds to gain between noise source and input of approximately 50 to 100 dB for 5.2 dB noise source and 40 to 90 dB for 15.2 dB noise source.

**Input impedance:** 50 ohms nominal.

**AGC output:** nominally 0 to  $-6$  V from rear binding posts.

**Recorder output:** 1 mA maximum into 2000 ohms maximum.

**Power input:** 115 or 230 volts  $\pm 10\%$ , 50 to 60 Hz, 185 to 435 watts, depending on noise source and line voltage.

**Power output:** sufficient to operate 343A, 345B, 347A or 349A Noise Sources.

**Dimensions:** cabinet:  $20\frac{3}{4}$ " wide,  $12\frac{3}{4}$ " high,  $14\frac{1}{2}$ " deep (527 x 324 x 368 mm); rack mount: 19" wide,  $10\text{-}15\frac{3}{32}$ " high,  $13\frac{7}{8}$ " deep behind panel (483 x 266 x 353 mm).

**Weight:** net 43 lbs (19.4 kg), shipping 54 lbs (24.3 kg) (cabinet); net 37 lbs (16.7 kg), shipping 51 lbs (23 kg) (rack mount).

**Accessories furnished:** one 340A-16A Cable Assembly, connects noise figure meter to 347A or 349A Noise Source.

**Price:** HP 340B, \$715 (cabinet); HP 340BR, \$700 (rack mount); HP 342A, \$815 (cabinet); HP 342AR, \$800 (rack mount); not available in all countries.

### Specifications, 343A

**Frequency range:** 10 to 600 MHz.

**Excess noise:** 10 to 30 MHz, 5.20 dB  $\pm 0.20$  dB; 100 MHz, 5.50 dB  $\pm 0.25$  dB; 200 MHz, 5.80 dB  $\pm 0.30$  dB; 300 MHz, 6.05 dB  $\pm 0.30$  dB; 400 MHz, 6.30 dB  $\pm 0.50$  dB; 500 MHz, 6.50 dB  $\pm 0.50$  dB; 600 MHz, 6.60 dB  $\pm 0.50$  dB.

**Source impedance:** 50 ohms; swr less than 1.2, 10 to 400 MHz, and less than 1.3, 400 to 600 MHz.

**Dimensions:**  $23\frac{3}{4}$ " wide,  $2\frac{1}{2}$ " high, 5" deep (70 x 63 x 127 mm).

**Weight:** net  $\frac{3}{4}$  lb (0.34 kg); shipping 2 lbs (0.9 kg).

**Price:** HP 343A, \$100.

**Option 01:** spare noise diode(s) calibrated and supplied with instrument, add \$40 each.

### Specifications, 345B

(same weight and dimensions as 343A)

**Spectrum center:** 30 or 60 MHz, selected by switch.

**Excess noise:** 5.2 dB into conjugate load.

**Source impedance:** 50, 100, 200 or 400 ohms,  $\pm 4\%$ , as selected by switch; less than 1 pF shunt capacitance.

**Price:** HP 345B, \$125 (for operation at any two frequencies between 10 and 60 MHz in lieu of 30 and 60 MHz, add \$25).

### Specifications, 347A

HP Model	Range (GHz)	Excess noise (dB)	Approx. length		Price
			(in.)	(mm)	
S347A	2.60—3.95	15.1 $\pm 0.5$	22½	572	\$390
G347A	3.95—5.85	15.2 $\pm 0.5$	19	483	\$310
J347A	5.30—8.20	15.2 $\pm 0.5$	19	483	\$300
H347A	7.05—10.0	15.7 $\pm 0.5$	16	406	\$275
X347A	8.20—12.4	15.7 $\pm 0.4$	14¾	375	\$225
P347A	12.4—18.0	16.0 $\pm 0.5$	14¾	375	\$275

SWR for all models, fired or unfired, 1.2 maximum.

### Specifications, 349A

**Frequency range:** 400 to 4000 MHz, wider with correction.  
**Excess noise:** 15.6 dB  $\pm 0.6$  dB, 400 to 1000 MHz; 15.7 dB  $\pm 0.5$  dB, 1000 to 4000 MHz.

**SWR:**  $< 1.35$  (fired),  $< 1.5$  (unfired) up to 2600 MHz;  $< 1.5$  (fired or unfired), 2600 to 3000 MHz;  $< 2.0$  (fired),  $< 3.0$  (unfired) 3000 to 4000 MHz.

**Dimensions:** 3" wide, 2" high, 15" long (76 x 51 x 381 mm).

**Weight:** net  $3\frac{1}{4}$  lbs (1.4 kg); shipping 6 lbs (2.7 kg).

**Price:** HP 349A, \$325.



# Analyzers ... Distortion, Wave, Spectrum



# WAVE AND DISTORTION ANALYZERS



# ANALYZERS

The choice between a wave analyzer and distortion analyzer depends on the information desired. The wave analyzer is a narrow-band filter which is tuned to select and measure the strength of the individual components of a signal one at a time (Figure 1). (In the frequency range from 10 MHz to 40 GHz, wave analysis is accomplished with the HP 851B/8551B Spectrum Analyzer, see pages 394 through 399.) In contrast to the frequency selection of wave analyzers, the distortion analyzer is a narrow-band rejection filter which, when properly tuned, removes the fundamental frequency so that the amplitude of the remaining components can be measured simultaneously (Figure 2). The distortion analyzer is used for fast, quantitative measurements of total distortion; whereas the wave analyzer provides detailed information concerning each harmonic and intermodulation product.

A signal becomes distorted whenever it passes through a non-linear circuit or network. Percentage distortion is defined as 100 times the ratio of the root-mean-square sum of the harmonics to the fundamental.

% distortion =

$$\frac{(A_2^2 + A_3^2 + A_4^2 + \dots)^{1/2}}{A_1} \times 100$$

where  $A_1$  is the rms amplitude of the fundamental and  $A_2, A_3, A_4, \dots$  are the amplitudes of the individual harmonics.

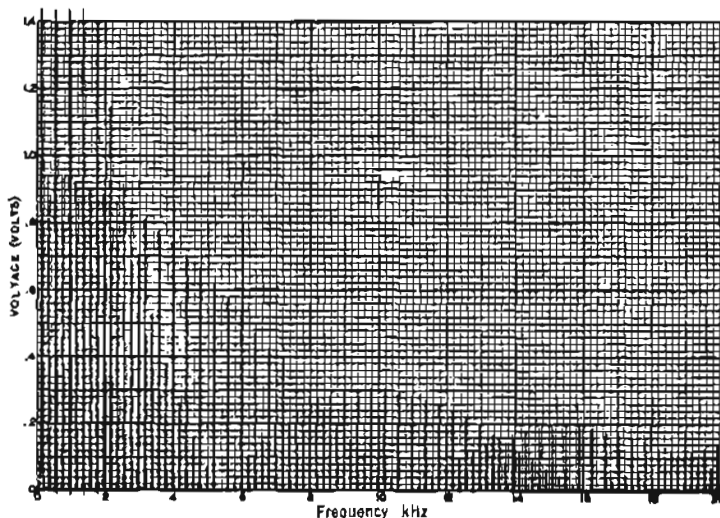

Figure 1. Harmonic analysis of slightly unsymmetrical square wave. Several harmonics were allowed to run off scale so the smaller, higher order harmonics are clearly visible.

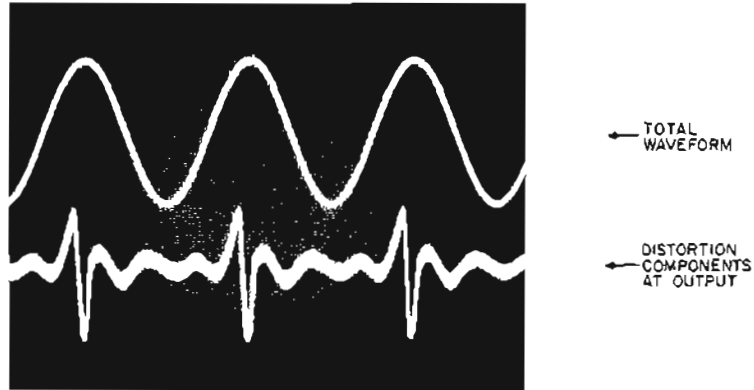

Figure 2. Output signal of nonlinear system, with the fundamental filtered out, is the lower trace on the oscilloscope's screen. The residual output shows that a seemingly pure sine wave does, in fact, contain harmonics.

## Distortion analyzers

Total harmonic distortion (THD) measurements are made by applying a sine-wave signal of high purity to the input of a system under test while the distortion analyzer measures the system output. A tunable notch filter in the analyzer suppresses the signal fundamental, leaving the distortion components to be

measured by the analyzer's voltmeter circuits. The ratio of the measured distortion components to the total signal output, including fundamental is defined as the distortion and can be read directly on the meter.

The THD method is fast in that it is only necessary to establish a reference level with the filter switched out and then make a reading with the filter, tuned to reject the fundamental. The measurement can now be made quickly at several frequencies within the passband of interest.

Viewing the distortion products presented at the distortion analyzer output terminals can also provide considerable supplementary information about system performance (see Figure 2). Small oscillations or discontinuities that may not be noticeable on the total waveform are seen on the oscilloscope display of the residuals. Noise, hum, and other non-harmonically related interference can also be identified.

Distortion analyzers also provide other information about the performance of a system. Gain or loss, frequency response, and noise may be measured at the same time distortion measurements are made by using the instrument as a broadband ac voltmeter.

## Distortion analyzers

The TOTAL HARMONIC DISTORTION method of analyzing the effects of system nonlinearity has been popular for a number of years because of the speed of making the measurement and simplicity of the equipment needed. The method is now more practical, permitting the signal-filtering part of the measurement to be performed automatically.

Two 5 Hz to 600 kHz distortion analyzers (HP 333A and 334A) have been designed with circuits that automatically tune the rejection filter to suppress the fundamental of the input signal while the remaining signal components are measured. The operator need only tune the filter approximately to the null and switch to the automatic mode, whereupon the instrument seeks the true null and retains it. Distortion measurements that formerly required patience and considerable skill, because of the sharpness of the rejection filter, may now be performed without requiring extensive operator training. Besides simplifying distortion measurements, automatic nulling also assures accuracy and repeatability, especially if the test signal tends to drift.

In addition to automatic nulling, Hewlett-Packard Distortion Analyzers have undergone other refinements. Distortion levels lower than 0.03% are easily resolved since the most sensitive range of the distortion-measuring circuits is 0.1% full scale (300  $\mu$ V) and the noise level is less than 25  $\mu$ V rms.

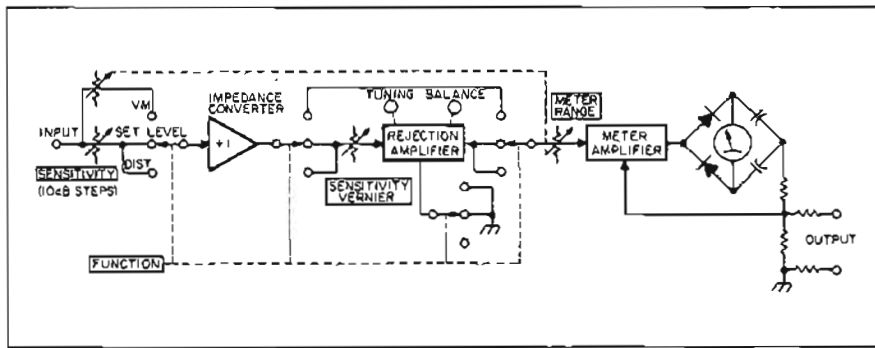

Figure 3. Elements of Distortion Analyzer Instrument function as broadband calibrated ac voltmeter in 'Voltmeter' mode and as signal-level indicator in 'Set Level' mode. In 'Distortion' mode, Rejection Amplifier can be tuned to suppress fundamental frequency of input signal, permitting comparison of distortion component's level to total signal level.

The rejection-filter tuning-range is 5 Hz to 600 kHz. The voltage-measuring frequency range has been extended to 3 MHz, so the instrument measures frequency components as high as the fifth harmonic of 600 kHz signals.

To reduce interference from power-line hum, if present in the signal being mea-

sured, each analyzer has a switchable high-pass filter for use with input signals higher than 1 kHz. The filter attenuates 60 Hz power-line interference by more than 40 dB. Rear-panel terminals permit operation from batteries, should it be desired to eliminate ground loops arising from power-line interconnections.

The HP 332A and 334A Analyzers also have an RF detector for distortion measurements of the modulating waveform on the carrier of AM radio transmitters. A meter with VU ballistic characteristics is available in analyzers that are to be used for performance checks conforming to FCC regulations.

The basic design of Hewlett-Packard Distortion Analyzers essentially follows ac voltmeter practice, in that there is a low-noise impedance-converter at the input, followed by an attenuator, a broadband amplifier, an ac-to-dc converter, and a meter, as shown in the block diagram of Figure 3. The tunable rejection amplifier is switched in or out as required.

The impedance converter uses a field-effect transistor (FET) to obtain exceptionally high input-impedance and a noise level that is less than 25  $\mu$ V referred to the input (600 ohm source impedance).

The ac-to-dc converter circuit is of the type wherein each diode conducts for a full half-cycle. The meter thus responds to the average value of the waveform, but is calibrated to read the rms value of a sine-wave. Ordinarily, any difference

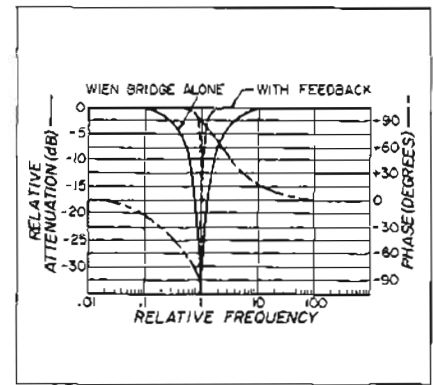

Figure 4. Frequency response characteristics across corners of Wien bridge with and without overall amplifier feedback. Diagram also shows phase plot, which has discontinuity from  $+90^\circ$  to  $-90^\circ$  at center of rejection notch.

The OUTPUT terminals supply a voltage proportional to the current supplied to the meter rectifiers. The output is taken from the calibration network in the feedback circuit of the meter amplifier, so at frequencies up to 600 kHz the output waveform is not subject to the diode cross-over distortion that has been characteristic of earlier average-responding circuits. Maximum output, corresponding to full-scale meter deflection, is 0.1 V rms.

During a distortion measurement, the fundamental component of the signal is rejected by the tunable Wien bridge in the interstage-coupling network of the rejection amplifier. To prevent attenuation of harmonics, the distortion analyzer uses feedback around the rejection amplifier to flatten the overall response, except in the deepest part of the notch where the Wien bridge attenuation is greater than available amplifier gain. With feedback, sharpness of the null is increased, as shown by the dotted line in Figure 4. The notch width is only 0.007% of the center frequency at the  $-70$  dB points and the second harmonic is attenuated typically less than 0.2 dB within a fundamental range of 20 Hz to 20 kHz, while the fundamental is attenuated more than 80 dB.

## Automatic null

The automatic nulling system is based on the phase characteristics of the Wien bridge, plotted as the dashed line in Figure 4.

As shown, the phase of the residual signal across the corners of the bridge lags the driving signal by  $90^\circ$  if the bridge is tuned slightly below the signal frequency; it leads by  $90^\circ$  if the bridge is tuned above. A phase-sensitive detector therefore is able to sense any mistuning and is able to indicate the direction that a correction should take. Automatic re-



adjustment is provided by photoconductors in the arms of the bridge.

The null-seeking circuits are able to track frequency deviations of at least 1%. If the frequency should vary, typical instrument-response time is on the order of 5 seconds for a 1% step change in frequency, assuring minimum delay in the measurement compared to manual nulling.

The bridge is self-compensating for temperature changes. The servo action of the automatic nulling circuitry maintains the null at all times, even though photoconductors tend to drift with changes in temperature.

Automatic nulling greatly simplifies using a distortion analyzer and makes certain that the null is retained, assuring accuracy and repeatability. Automatic nulling is also less subject to certain tuning errors. For instance, experience has shown that there may be slight differences between the null obtained by manual tuning and that obtained by use of the "Automatic" mode.

This can occur if the phase of the harmonics is such that a small amount of fundamental reduces the total area of the residual waveform. Slight manual mistuning of the rejection amplifier may result in an artificially low null. On the other hand, the phase detectors of the automatic nulling system respond primarily to the magnitude of the fundamental and do not attempt to minimize the total waveform passed to the metering circuit. Hence, automatic nulling is less subject to this type of error.

### RF detector

The broadband RF detector in the Hewlett-Packard analyzers is untuned and accepts RF signals greater than 1 V within a range of 550 kHz to 65 MHz. In the broadcast band (550-1600 kHz), the detector introduces less than 0.3% distortion on 3.8 V rms carriers modulated 30%.

### Battery operation

Terminals on the rear panel connect to the power supply regulators in the analyzer, permitting the instrument to be operated from batteries when it is advantageous to eliminate ground loops arising from power-line inter-connections. Two batteries are required, each within a voltage range of 28 to 50 V, and each capable of supplying 80 mA.

The switched high-pass filter in the Automatic Nulling Distortion Analyzer removes ac pickup that may interfere with the measurement. It attenuates 60 Hz hum components by more than 40 dB.

The Distortion Analyzer just described is one of four Hewlett-Packard Analyzers

using the same measuring circuitry with wide-filter tuning range (5 Hz to 600 kHz) and broad voltmeter frequency range (up to 3 MHz).

For applications where lower initial cost is more important than speed and convenience of automatic nulling, Models 331A and 332A have precision mechanical drives for accurate manual tuning without automatic nulling (switched high-pass filter is also omitted). Model 332A has an RF detector, but Model 331A does not.

Model 333A is identical to the Model 334A Automatic Nulling Distortion Analyzer except that the RF detector is omitted.

### Wave analyzers

The wave analyzer is a highly selective voltmeter. In operation the instrument is tuned to the frequency of the signal component to be measured. The amplitude of this component is read directly on the front-panel meter. Analysis of a complex waveform with a wave analyzer permits measurement of intermodulation (IM) distortion, harmonic content (Figure 1), and any spurious components such as hum which may appear in the input signal. Such information is useful, for instance, in the design and testing of amplifiers, mixers, and oscillators. In analysis of waveforms obtained from vibration systems, system resonance can be pinpointed by the presence of larger than normal harmonic components.

Hewlett-Packard wave analyzers are heterodyning tuned voltmeters, which means simply that the input signal is heterodyned to a higher intermediate (IF) frequency by an internal local oscillator. Filtering is performed in the IF amplifiers, so the instrument's passband remains constant regardless of the instrument's tuning. Tuning the local oscillator shifts the various signal frequency components into the passband of the IF amplifiers. The output of the IF amplifiers is rectified and supplied to the metering circuit.

A tuning capacitor designed and built by Hewlett-Packard is used in the oscillator circuits of the 302A and 310A. This capacitor provides a linear rotation-vs.-frequency characteristic which facilitates tuning because the distance between frequency increments on the dial is constant throughout the tuning range of the instrument. The 312A uses a synthesis technique to provide a highly stable local oscillator, and the tuned frequency is indicated on an electronic counter which provides a digital readout with  $\pm 10$  Hz resolution. Thus all three wave analyzers separate closely spaced signals as easily at the high end of the tuning range as at the low end.

Two attenuators ensure that low-level harmonic content can be read with accuracy. The input attenuator is set according to the amplitude of the input signal, allowing maximum input amplitude without overloading of the linear amplifier and modulator. The second attenuator, in the IF amplifier and metering circuit, permits the amplitudes of harmonic components to be read with accuracy over as much as a 75 dB range.

Hewlett-Packard wave analyzers cover a broad frequency range from below 20 Hz up to 22 MHz. Model 302A covers the important audio frequency range, 20 Hz to 50 kHz. The 310A provides coverage in the video range 1 kHz to 1.5 MHz. The new 312A (see Communications Section, page 294) extends this coverage to 18 MHz (22 MHz with the H01-312A) for testing of multiplex communications systems, IF and video amplifiers and filters, etc.

IF Bandwidth is one of the most important characteristics of a wave analyzer. The 7 Hz bandwidth of the Model 302A permits the separation of very closely spaced signals. Models 310A and 312A offer front panel selection of three bandwidths: 200 Hz for maximum resolution; 1000 Hz to simplify calculations of noise-power/Hz measurements; and 3000 Hz for operation of the wave analyzer as a receiver. In this mode, IF bandwidth is sufficient to recover voice modulation from either standard AM or single sideband systems (a carrier reinsertion oscillator is provided to permit detection of either normal or inverted single sideband transmissions.)

An important use of wave analyzers is plotting amplitude vs. frequency, that is, frequency response characteristics of amplifiers,\* filters, attenuators, etc. A "tracking" oscillator, automatically tuned to the same frequency as the wave analyzer, greatly simplifies such measurements. Models 302A and 310A include an internal tracking oscillator. Model 313A Tracking Oscillator provides this function for the 312A Wave Analyzer. Semi-automatic plots of amplitude vs. frequency can be made using the Model 27A Sweep Drive and an X-Y Recorder.

Automatic frequency control, an important feature of Hewlett-Packard wave analyzers, greatly facilitates wave analysis. Because of the narrow passband of these instruments (less than 7 Hz in the Model 302A) a slightly unstable input signal can easily drift out of the passband during measurement. The automatic frequency control locks the analyzer's tuning to the frequency of the signal component, so that measurements are not affected by drift in the source signal.

\*See Hewlett-Packard Application Note 59, "Loop Gain Measurements with HP Wave Analyzers," for a more complete discussion.



## WAVE ANALYZER, SWEEP DRIVE

Measures wave components directly to 50 kHz  
Models 302A, 297A

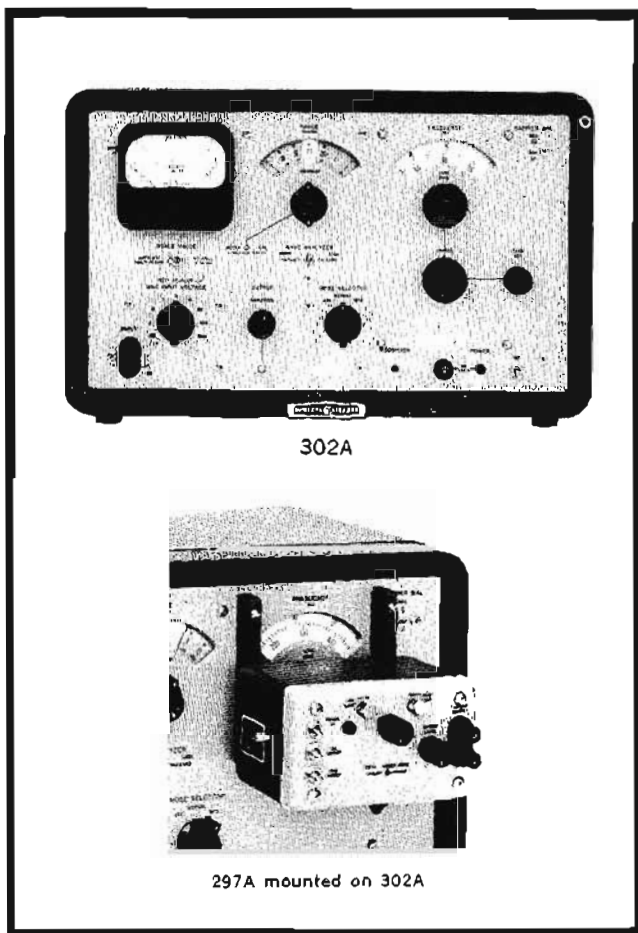

302A

297A mounted on 302A

The HP 302A Wave Analyzer functions as a highly selective tuned voltmeter separating the input signal into its individual components so that each—the fundamental, harmonics and any intermodulation products—may be evaluated separately.

The instrument operates by mixing the input signal with an internal oscillator adjusted to provide a difference frequency of 100 kHz. An automatic frequency control circuit maintains a constant difference frequency between the input and oscillator signals. This insures accurate measurements despite frequency drift in the input signal. After the input signal is mixed with a voltage from the internal oscillator, the 100 kHz difference signal is passed through a narrow-band crystal filter, amplified and metered.

### Frequency restorer

A frequency restorer circuit makes accurate frequency measurements possible at each component frequency of the input wave. The frequency restorer circuit supplies a sinusoidal signal at the frequency of the specific component to which the 302A is tuned. This signal can be measured on an electronic counter or observed on an oscilloscope. The amplitude of the restorer signal is determined by the level of the selected component.

Model 302A also is particularly useful for measuring small signals on noisy systems or transmission lines. When the mode selector is switched to "BFO" the instrument becomes an oscillator and tuned voltmeter automatically tuned by one control to the same or oscillator frequency. The selective tuned voltmeter then discriminates against the noise and measures the desired signal. Speed and accuracy of measuring are enhanced by a linearly calibrated tuning control giving the same "tuning feel" throughout the range.

### Specifications, 302A

**Frequency range:** 20 to 50,000 Hz.

**Frequency calibration:** linear graduation 1 division per 10 Hz.

**Dial accuracy:**  $\pm(1\% + 5 \text{ Hz})$ .

**Voltage range:** 30  $\mu\text{V}$  to 300 V full scale, 15 ranges in a 30, 100, 300 sequence; ranges provided by input attenuator and a meter range switch in steps of 1:3 or 10 dB; meter range is indicated by a dial mechanically linked with the input attenuator; an absolute-relative switch, in conjunction with a variable 10 dB control, is provided for adjustment of intermediate values.

**Warm-up time:** none.

**Voltage accuracy:**  $\pm 5\%$  of full scale value.

**Residual modulation products and hum voltage:** greater than 75 dB down.

**Intermediate frequency rejection:** intermediate frequency present in input signal rejected by at least 75 dB.

**Selectivity:**  $\pm 3.5$  Hz bandwidth at least 3 dB down,  $\pm 25$  Hz bandwidth at least 50 dB down,  $\pm 70$  Hz bandwidth at least 80 dB down; beyond  $\pm 70$  Hz bandwidth at least 80 dB down.

**Input impedance:** determined by setting of input attenuator: 100,000 ohms ( $< 100$  pF shunt) on 4 most sensitive ranges; 1 meg-ohm ( $< 20$  pF shunt) on remaining ranges.

**Restored frequency output:** 1 volt across 600 ohms at output terminals for full-scale meter deflection; output voltage proportional to meter reading; output level control provided; frequency response  $\pm 2\%$ , 20 to 50,000 Hz; output impedance approximately 600 ohms.

**Oscillator output:** 1 volt across 600 ohms at output terminals (mode selector in BFO); output level control provided; frequency response  $\pm 2\%$ , 20 to 50,000 Hz; output impedance approximately 600 ohms.

**Recorder output:** 1 mA dc into 1500 ohms or less at full-scale meter indication; for grounded or ungrounded recorders.

**Automatic frequency control:** range of frequency hold-in is  $\pm 100$  Hz minimum.

**Power:** 115 or 230 V  $\pm 10\%$ , 50 to 400 Hz, 3 W (approx.); terminals are provided for powering instrument from external battery source; battery supply range 28 V to 18 V.

**Dimensions:** cabinet: 20 $\frac{3}{4}$ " wide, 12 $\frac{1}{2}$ " high, 14 $\frac{1}{2}$ " deep (527 x 318 x 368 mm); rack mount: 19" wide, 10-15/32" high, 14" deep behind panel (483 x 266 x 356 mm).

**Weight:** net 43 lbs (19,5 kg), shipping 53 lbs (23,9 kg) (cabinet); net 35 lbs (16 kg), shipping 49 lbs (22,1 kg) (rack mount).

**Price:** HP 302A, \$1800 (cabinet); HP 302AR, \$1785 (rack mount).

### 297A Sweep Drive

The 297A is a motor drive unit designed to enhance the usefulness of the HP 302A, 310A or 312A Wave Analyzer. With the 297A you may sweep through all or any part of the 302A range. Because the 297A produces an x-axis output, you may easily make semi-automatic plots of harmonics, intermodulation products and response characteristics with an X-Y recorder such as Model 7035A.

The 297A also may be used to drive other tunable devices through their ranges. A stand (HP 11505A) allows the shaft height to be adjusted from 4 to 12 inches (102 to 305 mm).

### Specifications, 297A

**Sweep limits:** any interval from 64 revolutions to 10 degrees.

**Sweep speed with 302A:** 170 and 17 Hz/sec.

**Shaft speed:** 10 rpm, 1 rpm, and neutral; other shaft speeds available on special order; neutral permits manual operation.

**Sweep voltage output:** at least 12 volts maximum; full output is obtained with either 2.1 or 50 revolutions of the shaft.

**Torque:** 9 in-oz at 10 rpm (approx. 22 in-oz max. at 1 rpm).

**Power:** 115 volts  $\pm 10\%$ , 60 Hz, 12 watts running or stalled.

**Weight:** net 4 $\frac{1}{4}$  lb (1,9 kg), shipping 7 lb (3,2 kg).

**Price:** HP 297A, \$350; HP H03-297A (230 V, 50 Hz), \$375.

# WAVE ANALYZER

Measure harmonics, intermodulation products

Model 310A



# ANALYZERS

The HP 310A High-Frequency Wave Analyzer separates an input signal so that the fundamental, harmonics or intermodulation products can be analyzed. Any signal component between 1 kHz and 1.5 MHz may be selected for measurement. Additionally, a front-panel mode switch lets the 310A function as an efficient tuned voltmeter for accurately measuring relative or absolute signal levels, as a signal source for selective response measurements and as either an AM receiver or carrier reinsertion oscillator for demodulating single sideband signals.

High sensitivity of 10  $\mu$ V full scale, combined with the wide dynamic range of 75 dB, allows measurements of both weak harmonic components down to 1  $\mu$ V and strong signals up to 100 V. A switch above the input attenuator can be flipped from Absolute to Relative to permit signal readings at any arbitrary point on the meter for relative-strength measurements of harmonic components.

Three bandwidths, selected with a front-panel control, increase the versatility of the 310A. The 200 Hz bandwidth discriminates between harmonics for exact identification. The 1 kHz bandwidth simplifies calculations of noise power per cycle bandwidth. The 3 kHz bandwidth admits carrier channel signals for evaluation and is wide enough to pass intelligible voice signals, but contributes so little noise that even the 10  $\mu$ V range can be used.

Tuning is linear throughout the 310A's range, with no band switching. Frequency can be read easily from a 4-place digital dial which has a resolution of better than 200 Hz over the entire band, with any setting accurate to  $\pm(1\% + 300 \text{ Hz})$ .

Among the features which make the 310A more versatile are APC, restored frequency output and a beat frequency oscillator. The AFC has a dynamic hold-in range of  $\pm 3 \text{ kHz}$  (at 100 kHz) with response rapid enough to lock signals with drift rates in excess of 100 Hz/sec. The restored frequency output contains only that part of the input signal to which the instrument is tuned and so may be counted for exact frequency determination. The BFO converts the 310A into a signal source-tuned voltmeter, with a single tuning control, ideally suited for making selective or narrow-band response tests on filter circuits and transmission systems.

## Specifications

**Frequency range:** kHz to 1.5 MHz (200 Hz bandwidth); 5 kHz to 1.5 MHz (1000 Hz bandwidth); 10 kHz to 1.5 (3000 Hz bandwidth).

**Frequency accuracy:**  $\pm(1\% + 300 \text{ Hz})$ .

**Frequency calibration:** linear graduation, 1 div per 200 Hz.

**Selectivity:** 3 IF bandwidths, 200 Hz, 1000 Hz and 3000 Hz; mid-point of the passband ( $f_0$ ) is readily distinguished by a rejection region 1 Hz wide between the 3 dB points.

	200 Hz bandwidth	1000 Hz bandwidth	3000 Hz bandwidth
<b>Rejection*</b>	<b>frequency (Hz)</b>	<b>frequency (Hz)</b>	<b>frequency (Hz)</b>
$\geq 3 \text{ dB}$	$f_0 = 108$	$f_0 = 540$	$f_0 = 1550$
$\geq 50 \text{ dB}$	$f_0 = 500$	$f_0 = 2400$	$f_0 = 7000$
$\geq 75 \text{ dB}$	$f_0 = 1000$	$f_0 = 5000$	$f_0 = 17000$

\*Rejection increases smoothly beyond the -75 dB points.

**Voltage range:** 10  $\mu$ V to 100 V full scale, ranges provided by input attenuator and meter range switch in steps of 1.3 or 10 dB.

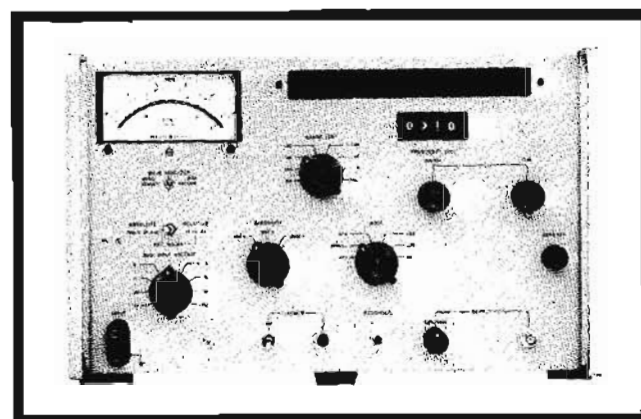

**Voltage accuracy:**  $\pm 6\%$  of full scale.

**Internal calibrator stability:**  $\pm 1\%$  of full scale.

**Dynamic range:** greater than 75 dB.

**Noise and spurious response:** at least 75 dB below a full-scale reference set on the 0 dB position of Range switch.

**Input resistance:** determined by input attenuator; 10 k ohms on most sensitive range; 30 k ohms on next range; 100 k ohms on other ranges; shunt capacitance  $< 100 \text{ pF}$  on three most sensitive ranges,  $< 50 \text{ pF}$  on other ranges.

**Automatic frequency control:** dynamic hold-in range is  $\pm 3 \text{ kHz}$ , minimum, at 100 kHz; tracking speed is approximately 100 Hz/sec; locks on signal as low as 70 dB below a full-scale reference set on the 0 dB position of the Range switch.

**Restored-frequency output:** restored signal frequency maximum output is at least 0.25 volt (meter at full scale) across 135 ohms, with approximately 30 dB of level control provided; output impedance approximately 135 ohms.

**BFO output:** 0.5 V across 135 ohms with approx. 30 dB of level control provided; output impedance approx. 135 ohms.

**Recorder output:** 1 V dc into an open circuit from 1000-ohm source impedance for single-ended recorders; output of 1 mA dc into 1500 ohms or less available on special order.

**Receiver function (Aural or Recording provision):** internal carrier reinsertion oscillator is provided for demodulation of either normal or inverted single sideband signals; AM signal also can be detected.

**RFI:** conducted and radiated leakage limits are below those specified in MIL-I-6181D.

**Power:** 115 or 230 V  $\pm 10\%$ , 50 to 400 Hz; approx. 16 W.

**Dimensions:** 16 $\frac{3}{4}$ " wide, 10 $\frac{3}{4}$ " high, 18 $\frac{3}{8}$ " deep (426 x 274 x 467 mm); hardware furnished for conversion to rack mount 19" wide, 10-15/32" high, 16 $\frac{3}{8}$ " deep behind panel (483 x 266 x 416 mm).

**Weight:** net 45 lbs (20.3 kg); shipping 53 lbs (23.9 kg).

**Accessories available:** 11001A Cable Assembly, \$5.50; 10503A Cable Assembly, \$6.50; 10111A Adapter, \$7; 297A Sweep Drive, \$35; 11505A Bench Stand for 297A, \$25; K02-310A Bracket for mounting the 297A when the 310A is rack-mounted, \$35.

**Price:** HP 310A, \$2200.

## Options

- Internal frequency calibrator providing check points every 100 kHz; interpolation accuracy (between check points):  $\pm 2 \text{ kHz}$  up to 1.4 MHz,  $\pm 3 \text{ kHz}$  between 1.4 and 1.5 MHz, add \$105.
- dB scale uppermost on meter face and extended to -25 dB; add \$25.

For signal analysis to 18 MHz, see HP Model 312A in the Communications Section.



## DISTORTION ANALYZERS

Accurate distortion readings, 5 Hz to 600 kHz  
Models 331A, 332A, 333A, 334A

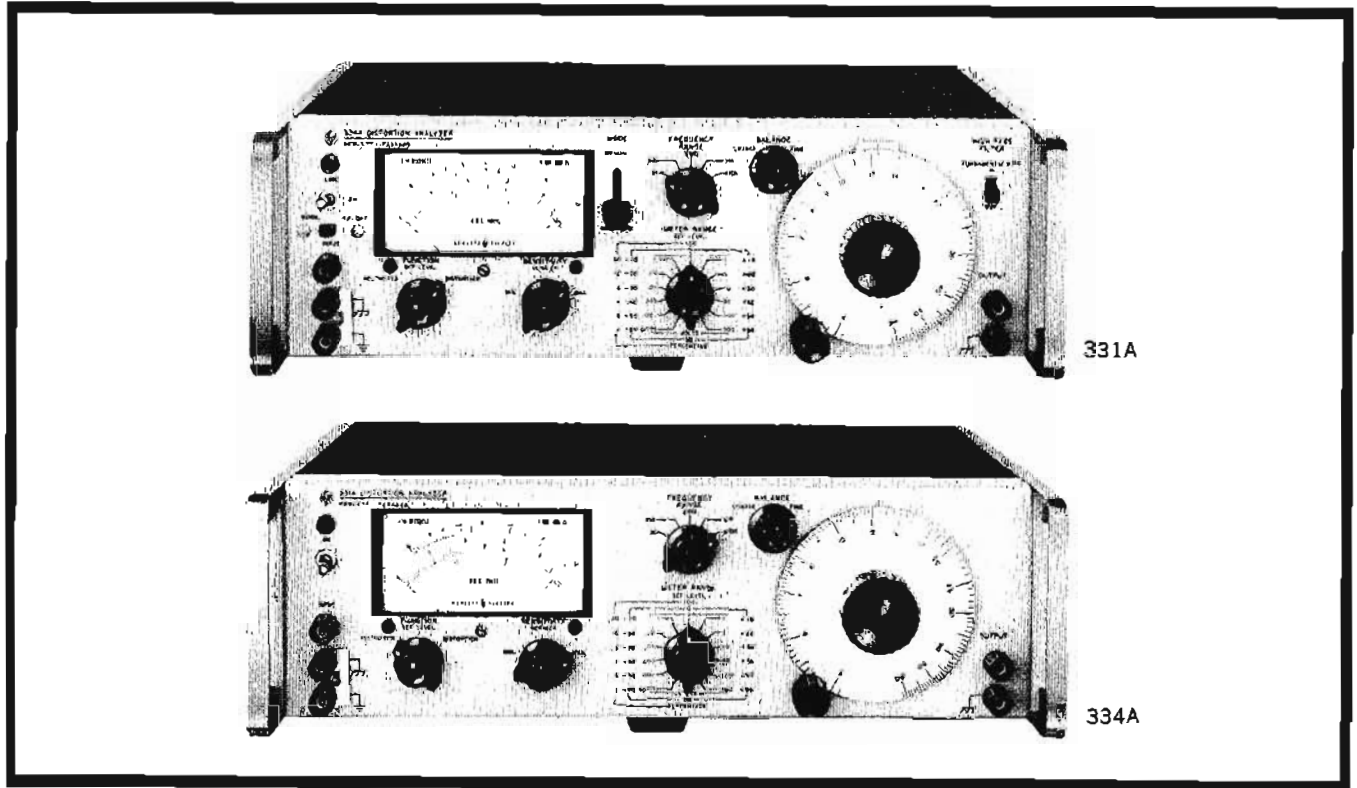

### Description

Distortion Analyzers have gone solid-state, offering extended tuning range, greater set-level sensitivity, improved selectivity and greater overall accuracy. The Model 331A, 332A, 333A, 334A Distortion Analyzers measure total distortion down to 0.1% full scale at any frequency between 5 Hz to 600 kHz; harmonics are indicated up to 3 MHz. These instruments measure noise as low as 50 microvolts, and measure voltages over a wide range of level and frequency. All four models may be used as sensitive wide-range transistorized voltmeters for general-purpose voltage and gain measurements.

#### Automatic Fundamental Nulling

Automatic fundamental nulling (available in HP Models 333A and 334A) speeds up the normally time-consuming portion of the measurement. This is done by manually nulling with the coarse tuning and balance controls to less than 10% of the Set-Level Reference. The automatic mode is used to complete rejection of the fundamental on more sensitive ranges without any further manual tuning.

#### Amplitude Modulation Detector

The HP Models 332A and 334A Analyzers are provided with an amplitude modulation detector having a frequency range from 550 kHz to greater than 65 MHz.

The high-impedance dc restoring peak detector which utilizes a semiconductor diode measures distortion at carrier

levels as low as 1 V. The input to the detector is located on the rear of the instrument. The Model 334A is similar to Model 332A, but is provided with Automatic Fundamental Nulling and a High-Pass Filter.

#### High-Pass Filter

In order to reduce the effect of hum components, a high-pass filter is provided which attenuates frequencies below 400 Hz. The filter may be activated by a front-panel switch when measuring distortion of signals greater than 1 kHz in frequency.

#### High-Impedance Voltmeter

The transistorized ac voltmeter, part of the HP 331A through 334A, provides 13 ranges from 300  $\mu$ V to 300 V rms full scale.

#### Models and available features

Model No.	Automatic Fundamental Nulling	Hi-Pass Filter	AM Detector	Gear Reduction Tuning	VU Meter
331A				X	Option: 01
332A			X	X	Option: 01
333A	X	X			Option: 01
334A	X	X	X		Option: 01

## Specifications

### Model 331A

**Distortion measurement range:** any fundamental frequency, 5 Hz to 600 kHz. Distortion levels of 0.1%-100% are measured full scale in 7 ranges.

**Distortion measurement accuracy:**

**Harmonic measurement accuracy:**

#### Fundamental Input Less Than 30 V

Range	$\pm 3\%$	$\pm 6\%$	$\pm 12\%$
100%-0.3%	10 Hz-1 MHz	10 Hz-3 MHz	
0.1%	30 Hz-300 kHz	20 Hz-500 kHz	10 Hz-1.2 MHz

#### Fundamental Input Greater Than 30 V

Range	$\pm 3\%$	$\pm 6\%$	$\pm 12\%$
100%-0.3%	10 Hz-300 kHz	10 Hz-500 kHz	10 Hz-3 MHz
0.1%	30 Hz-300 kHz	20 Hz-500 kHz	10 Hz-1.2 MHz

#### Elimination characteristics:

**Fundamental rejection** >80 dB.

#### Second harmonic accuracy for a fundamental of:

5 to 20 Hz: better than +1 dB.

20 Hz to 20 kHz: better than  $\pm 0.6$  dB.

20 kHz to 100 kHz: better than -1 dB.

100 kHz to 300 kHz: better than -2 dB.

300 kHz to 600 kHz: better than -3 dB.

**Distortion introduced by instrument:** <0.03% from 5 Hz to 200 kHz; <0.06% from 200 kHz to 600 kHz.

Meter indication is proportional to the average value of a sine wave.

#### Frequency calibration accuracy:

Better than  $\pm 2\%$  from 10 Hz to 200 kHz.

Better than -3% from 5 to 10 Hz.

Better than +8% from 200 to 600 kHz.

**Input impedance:** distortion mode: 1 megohm shunted by less than 60 (\*80) pF (10 megohms shunted by <10 pF with HP 10001A Divider Probe).

**Voltmeter mode:** 1 megohm shunted by 30 (\*50) pF 1 to 300 V rms; 1 megohm shunted by 60 (\*80) pF, 300  $\mu$ V to 0.3 V rms.

**Input level for distortion measurements:** 0.3 V rms for 100% set level or 0.245 V for 0 dB set level. (Up to 300 V may be attenuated to set-level reference.)

**DC isolation:** signal ground may be  $\pm 400$  V dc from external chassis.

**Voltmeter range:** 300  $\mu$ V to 300 V rms full scale (13 ranges) 10 dB per range.

**Voltmeter accuracy:** (Using front panel input terminals.)

Range	$\pm 2\%$	$\pm 5\%$
300 $\mu$ V	30 Hz-300 kHz	20 Hz-500 kHz
1 mV-30 V	10 Hz-1 MHz	5 Hz-3 MHz
100 V-300 V	10 Hz-300 kHz	5 Hz-500 kHz

**Noise measurements:** voltmeter residual noise on the 300  $\mu$ V range: <25  $\mu$ V rms, when terminated in 600 ohms, <30  $\mu$ V rms terminated with a shielded 100 k ohm resistor.

\*With rear input modifications.

**Output:** approximately 0.1 V rms output for full scale meter deflection.

**Output impedance:** 2 kilohms.

**Power supply:** 115 or 230 volts  $\pm 10\%$ , 50 to 1000 Hz, approximately 4 watts. Terminals are provided for external battery supply. Positive and negative voltages between 30 V and 50 V are required. Current drain from each supply is 40 mA.

### Model 332A

Same as Model 331A except as indicated below:

**AM detector:** high impedance dc restoring peak detector with semiconductor diode operates from 550 kHz to greater than 65 MHz. Broadband input, no tuning is required.

**Maximum input:** 40 V p-p ac or 40 V peak transient.

**Distortion introduced by detector:** carrier frequency: 550 kHz-1.6 MHz: <0.3% for 3-8 V rms carriers modulated 30%. 1.6 MHz-65 MHz: <1% for 3-8 V rms carriers modulated 30%.

NOTE: distortion introduced at carrier levels as low as 1 V is normally <1% 550 kHz to 65 MHz for carriers modulated 30%.

### Model 333A

Same as Model 331A except as indicated below:

#### Automatic nulling mode:

Set level: at least 0.2 V rms.

Frequency ranges: X1, manual null tuned to less than 3% of set level; total frequency hold-in  $\pm 0.5\%$  about true manual null. X10 through X10 k, manual null tuned to less than 10% of set level; total frequency hold-in  $\pm 1\%$  about true manual null.

#### Automatic null accuracy:

5 Hz to 100 Hz; meter reading within 0 to +3 dB of manual null. 100 Hz to 600 kHz; meter reading within 0 to +1.5 dB of manual null.

**High-pass filter:** 3 dB point at 400 Hz with 18 dB per octave roll off. 60 Hz rejection >40 dB. Normally used only with fundamental frequencies greater than 1 kHz.

#### Frequency calibration accuracy:

Better than  $\pm 3\%$  from 5 Hz to 200 kHz.

Better than +8% from 200 kHz to 600 kHz.

**Power supply:** same as Model 331A except current drain from each supply is 80 mA.

### Model 334A

Same as Model 333A except includes AM Detector described under Model 332A.

### General

**Weight:** net 17 $\frac{3}{4}$  lbs (7.98 kg); shipping 26 lbs (11.79 kg).

**Dimensions:** 16 $\frac{3}{4}$ " wide, 5-7/32" high, 13 $\frac{1}{4}$ " deep (425.6 x 132.6 x 336.6 mm).

**Price:** HP 331A, \$590; HP 332A, \$620; HP 333A, \$760; HP 334A, \$790.

Option 01, indicating meter has VU characteristics conforming to FCC requirements for AM/FM and TV broadcasting; add \$15.



Spectrum analysis is the study of energy distribution across the frequency spectrum for a given electrical signal. Evaluation of the relative amplitudes and frequencies of the discrete components of rf signals yields information on bandwidths, modulation characteristics, spurious signal generation and other valuable data impossible or impractical to obtain by any other means.

Microwave spectrum analysis has assumed added importance since the introduction of the HP 851B/8551B and its versatile accessories. With its fully calibrated controls and displays, plus wide spectrum coverage, this analyzer brings welcome practicality to frequency-domain measurements and opens up new areas of application.

The basic frequency range of the HP Spectrum Analyzer is 10 MHz to 10 GHz. The addition of external waveguide mixers provides coverage from 8.2 GHz to 40 GHz. Low-frequency coverage of the Spectrum Analyzer can be extended to 10 kHz with the K15-8551B with improved sensitivity ( $-107$  dBm); see page 396.

Hewlett-Packard offers a second spectrum analyzer, E01-851B (page 399). This analyzer, comprising the 851B Display Unit, K10-8551B Converter Unit, and 8690A Sweep Oscillator, is intended primarily for use in a single frequency band. It utilizes fundamental mixing for high sensitivity and flat response.

### Broadband applications

Radio Frequency Interference (RFI) testing, spectrum surveillance and gathering of spectrum signatures—these are important fields being revolutionized by the HP spectrum analyzer. The far-ranging sidebands of radar transmitters, intermodulation products of multiple transmissions and spurious signals generated by electronic and electrical devices can be quickly detected and measured with

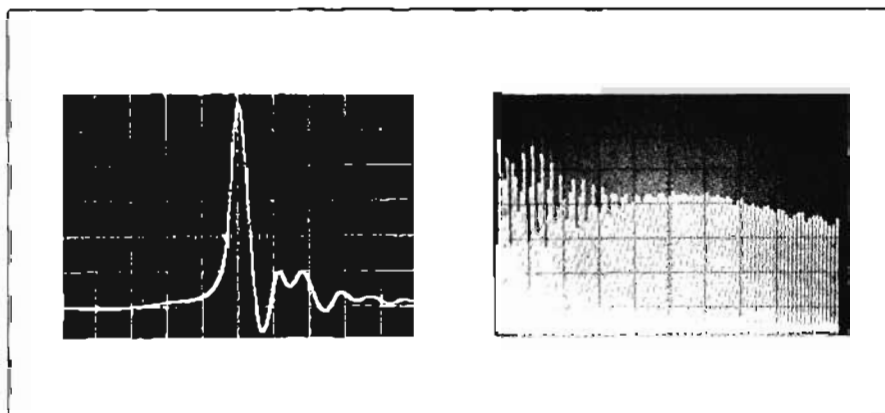

Figure 2. Nanosecond pulse and spectrum resulting.

the analyzer. Wide dynamic range and broad spectrum coverage in the HP spectrum analyzer permit measurements of signals widely separated in frequency and amplitude.

The HP 8441A Preselector is a valuable tool to aid RFI and spectrum surveillance measurements. The 8441A is a voltage-tuneable bandpass filter using a yttrium-iron-garnet (YIG) current-tuneable filter to pass a desired signal and reject others. By automatically tracking the desired spectrum analyzer tuning response, it virtually eliminates multiple, image, and spurious responses in the 1.8 to 12.4 GHz range. This greatly simplifies the display, making it easier to interpret. It is also possible to use the 8441A Preselector with a broadband crystal detector and a sensitive oscilloscope to form a simple spectrum analyzer. The Preselector can extend the dynamic range of the analyzer for distortion measurements as much as an additional 35 dB, permitting distortion measurements as low as 0.01%.

Transients and random interference can be recorded by a time-exposed photo of the analyzer's CRT display taken with an oscilloscope camera. Displays of repetitive signals may be plotted on an

x-y recorder, using the vertical and horizontal output signals from the analyzer. Figure 1 shows the radiation present throughout the entire vhf spectrum in a large metropolitan area as viewed on the HP spectrum analyzer. Note the cluster of FM broadcast stations on the left and the television aural and video carriers appearing at center-right of the display. This display represents only 15% of the analyzer's maximum spectrum width capability. Power density measurements are another important application of the spectrum analyzer, made possible by calibrated IF bandwidths. The HP Model 8442A 20 MHz Crystal Filter is a bandpass filter to improve the skirt characteristics of the 1 kHz IF of the 851B/8551B Spectrum Analyzer. This provides greater resolution of closely spaced signals having large differences in amplitude. By knowing the effective noise bandwidth of the IF amplifier, a calibrated output in terms of noise power per megacycle is possible using an rf indicator such as the HP 411A RF Millivoltmeter (page 197) to measure the analyzer's 20 MHz IF output. Calibration is achieved by feeding a known signal level into the analyzer rf input from a signal generator and noting the output level on the rf millivoltmeter. This level then becomes a reference to which all power density measurements may be referred.

### Solid-state applications

Tuning varactor multiplier strings and parametric amplifier circuits can be tedious and time consuming by conventional techniques. There also is a good chance that spurious signals may be present in the output of such devices, even when everything seems "peaked up" correctly. With the HP Spectrum Analyzer all output frequencies can be observed simultaneously for easy adjustment of such

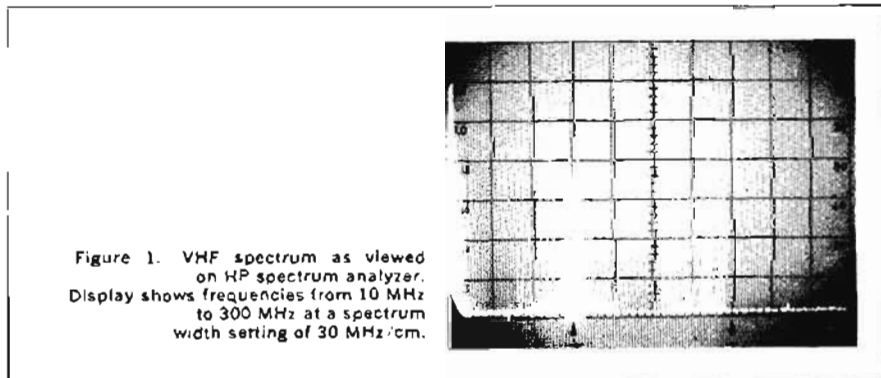

Figure 1. VHF spectrum as viewed on HP spectrum analyzer. Display shows frequencies from 10 MHz to 300 MHz at a spectrum width setting of 30 MHz/cm.



devices for optimum output free of spurious signals.

Fast rising, short duration pulse waveforms in the nanosecond region can be generated by semiconductor diodes driving a shorted transmission line. Often, it is desirable to obtain a uniform output across large segments of the spectrum with such devices (Figure 2). With the broad frequency display and flat amplitude response of the 851B/8551B, it is a simple task to measure narrow, fast rising pulse spectra and make adjustments for discontinuities in the generating system.

### Narrowband measurements

In addition to the broad spectrum capability of the analyzer, calibrated spectrum widths down to 10 kHz/cm allow detailed analysis of very narrow segments of the band. Spectrum width can be reduced to zero with a vernier for operation of the Spectrum Analyzer as a fixed-frequency receiver. A unique phase-lock stabilization system reduces local oscillator residual FM in the analyzer to less than 1 kHz peak-to-peak deviation when viewing narrower spectrum widths. This system permits stable displays of narrow spectra, plus the convenience of remaining stabilized while tuning across the band. Narrow spectrum widths are useful for applications such as FM deviation measurements and residual FM checks on signal sources. The 60 dB dynamic range and display makes FM measurements by the "carrier-zero" method extremely accurate since the modulation frequency may be adjusted to the precise point where all the signal energy is contained in the sidebands. The modulation frequency is measured on an electronic counter and noted. Then, using a table

of Bessel functions, carrier deviation is a simple calculation:

$$f_c = mf_a,$$

where  $f_c$  = carrier deviation  
 $m$  = modulation index (from Bessel table)  
 $f_a$  = modulation frequency

### Application Note 63

Well illustrated applications and specific information on Spectrum Analysis are yours for the asking in HP Application notes 63 and 63A. Application Note 63 contains an introduction to spectrum analysis explaining the basic principles of this important branch of microwave measurements and includes illustrations of spectral displays and their interpretation. An appendix provides a more rigorous treatment of the application of Fourier analysis to spectrum analyzer displays.

Both Application Notes contain spectrum analyzer applications in detail, suggesting time-saving methods and solutions of difficult measurement problems. Your copies of Application Notes 63 and 63A are available on request through HP Sales Offices in your area.

### Spectrum analyzer requirements

The basic functions of a spectrum analyzer are to translate electrical functions into their various frequency components and present their amplitudes on a visual display. To be versatile and do an effective job, the spectrum analyzer should have: 1) the ability to locate and identify signals over a wide frequency spectrum, 2) the ability to magnify portions of the spectrum for detailed analysis with stable calibrated sweeps and resolution, 3) minimum display clutter from spurious responses in the analyzer, and 4) wide dynamic range and flat frequency response.

A simplified block diagram of the HP 851B/8551B Spectrum Analyzer is shown in Figure 3. The rf section contains the local oscillators, mixers and two of the three IF amplifiers, comprising a triple conversion superheterodyne receiver. The first local oscillator is a backward wave oscillator which is capable of being swept or tuned from 2 to 4 GHz. Input signals of 10 MHz to 10 GHz pass through the 0-60 dB rf attenuator to a crystal harmonic mixer and are converted to the 2 GHz IF. After amplification, the 2 GHz IF is converted to 200 MHz, amplified, and converted again to 20 MHz. The use of a 2 GHz first IF keeps images 4 GHz apart, preventing a confusing double response for a single input frequency. The first mixer is carefully designed for minimum spurious generation and flat frequency response.

The display section contains the 20 MHz IF attenuator, bandpass filters, amplifiers, and video detector, plus the crt, sweep generator and display shapers.

Except for the crt, this section is designed with solid-state components throughout. The input consists of an accurate 0-80 dB attenuator calibrated in 1 dB steps. Bandpass filters, controlling the analyzer's resolution, follow the attenuator. These have accurately controlled bandwidths of 1, 3, 10, 100 kHz and 1 MHz. The switching logic of the Sweep Time and Spectrum Width selectors automatically select the optimum filter for best resolution without sacrifice in gain. Manual selection of the filters also is provided. A current controlled attenuator and feedback network comprise a display shaper which allows calibrated readout on the crt in terms of input power (square law), dB (logarithmic) or voltage (linear). A full discussion of spectrum analyzer design considerations is included in Application Note 63.

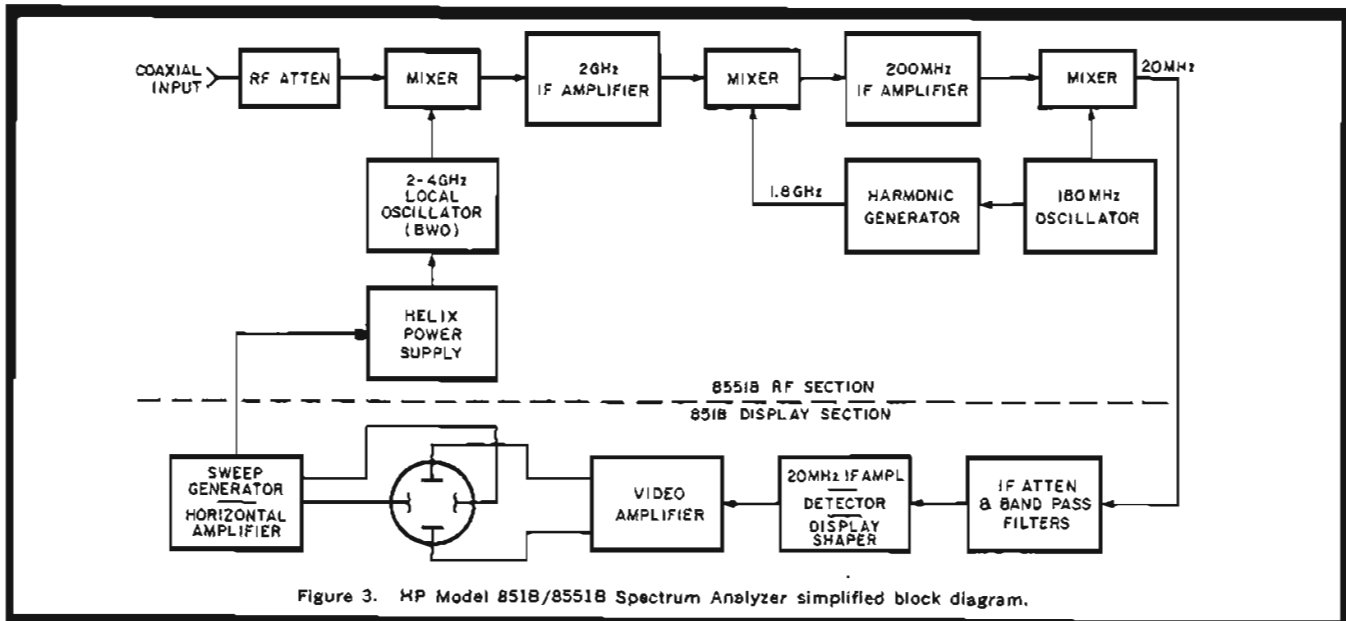

Figure 3. HP Model 851B/8551B Spectrum Analyzer simplified block diagram.



## ANALYZERS



## SPECTRUM ANALYZER; ACCESSORIES

Fully calibrated, 2 GHz spectrum width

Models 851B/8551B;

11517A-11521A, K15-8551B, 8406A, 8439A, 8442A

The Hewlett-Packard 851B/8551B Spectrum Analyzer is a fully calibrated, highly versatile analyzer which covers the range from 10.1 to 40 GHz. It provides a 60 dB display dynamic range, flat response over calibrated spectrum widths from 100 kHz to 2 GHz and image separation of 4 GHz. High sensitivity and broad frequency range, plus a unique signal identifier, are additional features which make this instrument the most versatile and useful spectrum analyzer available today.

## Maximum flexibility

An extremely wideband coaxial input system which accepts signals from 10.1 MHz to 10 GHz is provided. Use of the broadband, untuned first mixer permits simultaneous observation of widely spaced signals. When it becomes desirable or necessary to limit the input frequency range, appropriate preselectors (such as filters, isolators, etc.) can be added easily. The analyzer itself imposes no arbitrary frequency band limitations. Additional flexibility and convenience are provided by the inclusion of a high-performance RF attenuator for use when higher level signals are examined. The attenuator has 60-dB range in 10-dB steps, and because its residual attenuation is very small (less than 2 dB at 10 GHz), it can remain an integral part of the input system, thereby eliminating any need for cable patching.

Signals in waveguide systems also are analyzed easily and conveniently. External waveguide mixers covering 8.2 to 40 GHz are used, with a simple coaxial cable serving as the interconnecting link between the mixer and 8551B. The single cable both delivers local oscillator power to the mixer and returns the mixing products back to the analyzer.

Ten calibrated spectrum widths from 100 kHz to 2 GHz are available. This wide range of spectrum width permits observation of widely separated signals and broad spectra, as well as detailed examination of individual signals, distortion products, etc. Image separation of 4 GHz (a 2-GHz first IF) assures a

display uncluttered by overlapping images. For investigation of signals close to 2 GHz, a 200 MHz first IF can be selected.

## 60 dB display dynamic range

Any of three calibrated display modes can be selected for viewing a signal over a 7-cm vertical span: linear (voltage), square (power), or logarithmic (10 dB/cm). The log display is accurate to  $\pm 2$  dB over a full 60-dB range, a 20-dB extension of previously available analyzer display capability. A precision, direct-reading IF attenuator adds to the range of measurement and increases accuracy and convenience. The attenuator has an 80-dB range in 1-dB steps and includes a vernier for continuous adjustment between steps.

Calibrated IF bandwidths add to measurement accuracy and insure day-to-day repeatability of measurement conditions. Five bandwidths between 1 kHz and 1 MHz are available; each has good skirt selectivity consistency with the 60-dB display range for best display readability. For the utmost in selectivity when resolving closely spaced signals, an external filter (HP 8442A) can be added easily. The choice of IF bandwidth can be made manually or automatically. In the automatic mode, optimum bandwidth for best resolution of a CW signal is selected internally for each combination of sweep time and spectrum width. In addition, sweep time is calibrated, and the CRT has an internal graticule for parallax-free viewing. A base line clipper is provided to dim the baseline on the CRT for more comfortable viewing and improved photography of low-repetition rate signals.

## External waveguide mixers, adapters

External waveguide mixers 11517A and 11521A permit direct observation of signals in waveguide systems. The 11517A covers 12.4 to 40 GHz and requires adapters 11518A, 11519A, 11520A as transitions to P-, K-, R-band waveguide respectively. The 11521A Mixer covers X-band (8.2 to 12.4 GHz). Price: HP

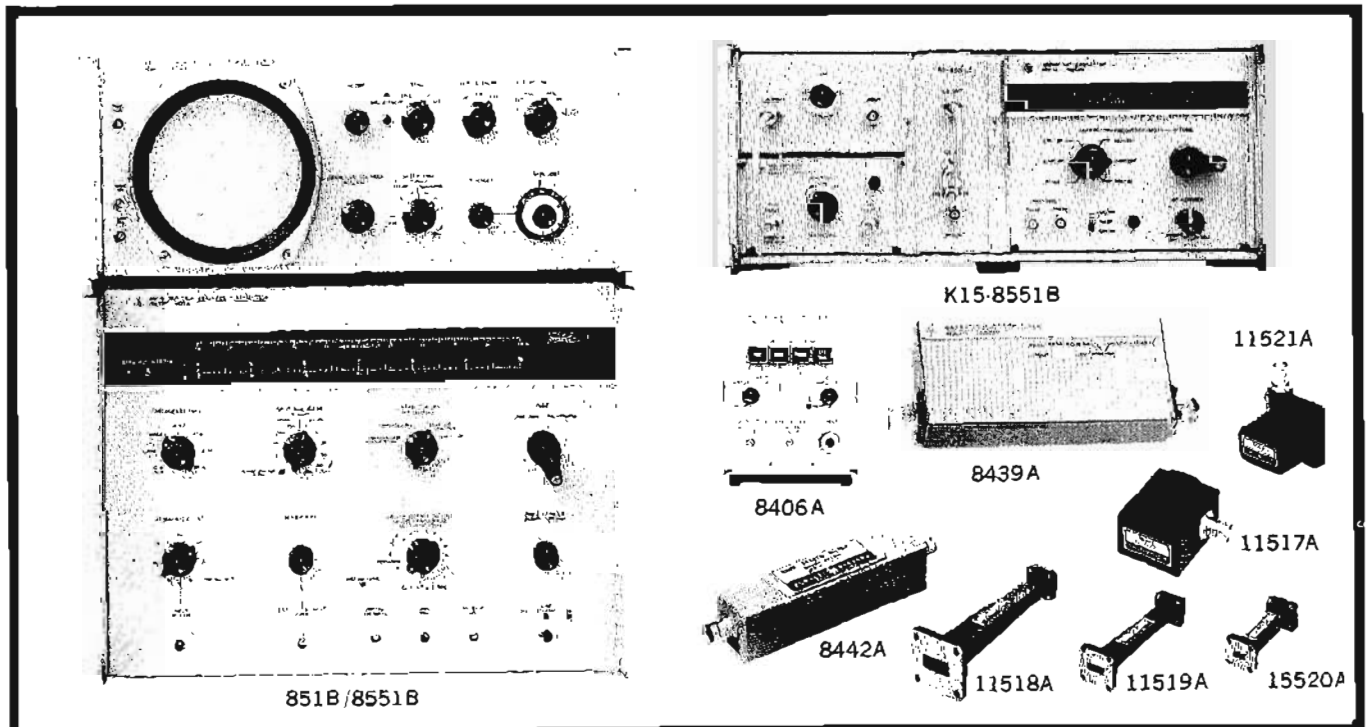

11517A Mixer (12.4-40 GHz), \$160; 11518A Adapter (12.4-18 GHz), \$65; HP 11519A Adapter (18-26.5 GHz), \$65; HP 11520A Adapter (26.5-40 GHz), \$65; HP 11521A Mixer (8.2-12.4 GHz), \$75.

### K15-8551B Up-converter

The K15-8551B extends the lower-frequency limit of the 851B/8551B Spectrum Analyzer from 10 MHz to 10 kHz. With a sensitivity of about  $-107$  dBm ( $1 \mu\text{V}$ ) throughout this range, the Up-converter/Spectrum Analyzer combination is equally well suited to the laboratory and the field. For example, the combination can be used in the design of low-level transistor oscillators; it can also serve as a spectrum-surveillance monitor for control of interference in radio communication. For maximum flexibility, the Up-converter includes an input attenuator which provides up to 120 dB of attenuation in 10-dB steps plus an amplifier with 20 or 40 dB of gain. Price: HP K15-8551B, \$1555.

### 8406A Frequency Comb Generator

Model 8406A provides frequency markers spaced 1, 10, and 100 MHz for frequency calibration of the spectrum analyzer.

## Specifications, 8551B RF Section

#### Coaxial Input characteristics

**Frequency range:** 10.1 MHz to 10 GHz (usable to 12.4 GHz), input connector, type N female.

**Sensitivity** ( $\frac{\text{signal power} + \text{noise power}}{\text{noise power}} = 2$ ; 10 kHz IF bandwidth):

10.1 MHz to 1.8 GHz	$-95$ dBm, fundamental mixing
1.8 to 4.2 GHz	$-100$ dBm, fundamental mixing (using 200 MHz 1st IF)
2.2 to 4 GHz	$-92$ dBm, second harmonic mixing
4 to 6 GHz	$-93$ dBm, fundamental mixing
6 to 8 GHz	$-85$ dBm, third harmonic mixing
8 to 10 GHz	$-85$ dBm, second harmonic mixing

With source stability better than 1 kHz, greater sensitivity can be achieved using narrower IF bandwidth.

**Frequency response:** (includes mixer and RF attenuator response with attenuator setting  $\geq 10$  dB).

Frequency range	Mixing mode		Rel. gain (approx.)**	Flatness full range	Flatness 100 MHz
	n*	IF			
10.1 MHz to 1.8 GHz	1-	2 GHz	0 dB	$\approx 2.5$ dB	$\approx 1.5$ dB
1.8 to 4.2 GHz	1=	200 MHz	0 dB	$\approx 3.5$ dB	$\approx 2.0$ dB
2.2 to 4 GHz	2-	2 GHz	$-5$ dB	$\approx 2.5$ dB	$\approx 1.5$ dB
4 to 6 GHz	1+	2 GHz	$-3$ dB	$\approx 2.5$ dB	$\approx 1.5$ dB
6 to 8 GHz	3-	2 GHz	$-10$ dB	$\approx 2.5$ dB	$\approx 1.5$ dB
8 to 10 GHz	2+	2 GHz	$-10$ dB	$\approx 5.0$ dB	$\approx 1.5$ dB

\*n = LO harmonic.

\*\*The relative displayed amplitudes of equal-amplitude input signals for various harmonic mixing modes.

**Image separation:** 4 GHz (2 GHz First IF; 400 MHz separation when using 200 MHz IF).

**Residual responses (no input signal):** less than  $-90$  dBm referred to Signal Input on fundamental mixing ( $-85$  dBm when LO is within 60 MHz of 2 or 4 GHz).

**RF input attenuator:** 0 to 60 dB in 10-dB steps (attenuator residual loss and flatness characteristics included in sensitivity and frequency response specifications).

**Maximum input power (for 1 dB signal compression):**

Input atten. setting	Typical max. input (peak or average)
0 dB	$-5$ dBm
10 dB	$+5$ dBm
20 dB	$+15$ dBm
30 dB	$+25$ dBm
40-60 dB	$+30$ dBm

The markers are harmonics derived from 0.01% crystal oscillators, so accurate determination of absolute as well as relative frequencies is possible. An external oscillator can be used to produce a comb with different spacing; or each of the output combs can be phase modulated with external oscillators to produce sidebands about each tooth of the comb, thereby facilitating interpolation measurements. The combs are useable from the fundamental to beyond 5 GHz. Price: HP 8406A, \$500.

### 8442A 20 MHz Crystal Filter

This filter improves the skirt characteristics of the 1-kHz IF of the 851B Display Section for greater resolution of closely spaced signals. The filter bandwidth at the 60-dB points is less than 10 kHz. Price: HP 8442A, \$225.

### 8439A 2-GHz Notch Filter

Model 8439A has an extremely narrow rejection notch (2 MHz at 60 dB down) at 2 GHz, thereby permitting observation of broadband signals without interference from signals at the 2-GHz IF (evidenced by the raising of the entire baseline on the CRT). Price: HP 8439A, \$240.

#### Waveguide Input characteristics

**Frequency range:** 8.2 to 40 GHz (11517A-11521A accessory mixers and adapters required).

**Sensitivity** ( $\frac{\text{signal power} + \text{noise power}}{\text{noise power}} = 2$ ; 10 kHz IF bandwidth):

8.2 to 18 GHz	$-80$ dBm
18 to 26.5 GHz	$-75$ dBm
26.5 to 40 GHz	$-65$ dBm

**Maximum input power (for 1 dB signal compression):**

8.2 to 12.4 GHz (using 11521A Mixer), typically  $-15$  dBm peak or average; 12.4 to 40 GHz (using 11517A Mixer), typically  $-15$  dBm peak or average.

**Ext. mixer input connector:** BNC female; LO power to mixer and 2 GHz IF signal from mixer use this connector.

#### Sweep, LO, and tuning characteristics

**Spectrum width:** 10 calibrated spectrum widths from 100 kHz to 2 GHz in a 1, 3, 10 sequence to 1 GHz, vernier allows continuous adjustment between calibrated ranges and can be used to reduce width to 0; displayed over 10 cm horizontal span on 851B Display Section CRT.

**Swept frequency linearity:** spectrum widths 200 MHz/cm to 3 MHz/cm: frequency error between 2 points on the display is less than  $\pm 10\%$   $\pm 3$  MHz of the indicated frequency separation between the two points; spectrum widths 1 MHz/cm to 10 kHz/cm (stabilized tuning mode): frequency error between two points on the display is less than  $\pm 5\%$  of the indicated frequency separation between the two points.

**First local oscillator:** 2 to 4 GHz backward wave oscillator.

**Tuning accuracy:**  $\pm 1\%$  of LO fundamental or harmonic.

**Tuning modes:** selectable continuous coarse, fine and stabilized (phase-locked) tuning determines center frequency about which first Local Oscillator (LO) is swept. Tuning accomplished with single front panel Tune control (with Frequency Vernier control for increased settability when in stabilized tuning mode; Vernier tuning range 100 kHz). Frequency change of LO fundamental is 200 MHz per revolution of TUNE control for COARSE, 10 MHz per revolution for FINE.

**LO stabilization range:** first LO can be phase-locked to internal voltage-tuned reference oscillator; LO sweep tracks reference oscillator sweep for spectrum widths up to  $N \times 10$  MHz ( $N = \text{LO harmonic number}$ ).

**Stabilized tuning:** internal reference oscillator automatically tracks with Tune control over full LO range to retain

## ANALYZERS



## SPECTRUM ANALYZER, ACCESSORIES

(continued)

Fully calibrated, 2 GHz spectrum width

Models 851B/8551B;

11517A-11521A, K15-8551B, 8406A, 8439A, 8442A

stabilization at any LO frequency; frequency change of LO fundamental is 10 MHz per revolution of the Tune control; Frequency Vernier control (100 kHz tuning range) permits precise settability.

**LO characteristics:** residual FM: less than 1 kHz (p-p) when LO stabilized; typically less than 40 kHz (p-p) when LO not stabilized; noise sidebands: more than 60 dB below CW signal level 90 kHz or more away from signal, using fundamental mixing; auxiliary RF output: approximately 20 mW available at rear panel type N female connector for use with other equipment (e.g., frequency counter, wavemeter); requires nominal 50 ohm load impedance; HP 908A Termination furnished.

**General**

**Signal identifier:** front panel switch introduces precise frequency offsets to permit exact determination of LO harmonic number used for mixing; direction of display shift indicates whether signal frequency is higher or lower than LO harmonic; concentric pushbutton switch permits re-establishment of reference position to facilitate identification of drifting signals.

**Self-check:** first IF of 2 GHz permits use of swept LO (tuned to 2 GHz) for calibration, alignment, and general performance checks; stabilized LO provides swept RF signal with very high linearity over 10 MHz range for IF bandwidth calibrations.

**IF output center frequency:** 20 MHz (at rear panel BNC female connector for use with 851B Display Section).

**RFI:** conducted and radiated leakage limits are below those specified in MIL-I-16910C.

**Power:** 115 or 230 V  $\pm 10\%$ , 50 to 60 Hz, < 275 W (less than 300 W, total, when 851B Display Section power supplied through 8551B rear panel switched line output).

**Weight:** net 88 lbs (39,6 kg); shipping 134 lbs (60,3 kg).

**Dimensions:** 16 $\frac{3}{4}$ " wide, 12 $\frac{1}{2}$ " high, 18 $\frac{3}{4}$ " deep (425 x 318 x 467 mm); hardware furnished for rack mount 19" wide, 12-7/32" high, 16 $\frac{3}{8}$ " deep behind panel (483 x 177 x 416 mm).

**Accessory items furnished:** rack mounting kit; cables to connect 8551B RF Section to 851B Display Section; 908A Termination for rear panel auxiliary LO Output.

**Price:** Model 8551B, \$7100.

**Specifications, 851B Display Section****Display characteristics**

Vertical display (7 cm full scale deflection):

Mode	Scale factor	Accuracy
Linear	Relative voltage/cm	$\pm 3\%$ full scale
Square	Relative power/cm	$\pm 5\%$ full scale*
Log	10 dB/cm calibrated over 0 to 60 dB on CRT Display	$\leq 0.1$ dB/dB but not more than $\pm 2$ dB over full calibrated 60 dB CRT display range*

**Cathode ray tube:** 7.5 kV post-accelerator tube with P2 medium persistence phosphor (others optional) and internal graticule; light blue filter supplied; light-proof CRT bezel provides firm mount for oscilloscope camera.

**CRT internal graticule:** parallax-free 7 x 10 cm, marked in centimeter squares with 2 mm subdivisions on major horizontal and vertical axes.

\*Except pulse spectra on 1 MHz IF bandwidth.

**CRT base line clipper:** front panel control permits blanking of CRT trace baseline to allow more detailed analysis of low repetition rate signals.

**IF characteristics**

**IF input center frequency:** 20 MHz (accepts 20 MHz output from 8551B RF Section).

**IF bandwidth:** manual: bandwidths of 1, 3, 10, 100 kHz, and 1 MHz can be selected; auto select: one of the above bandwidths automatically selected for best resolution of a CW signal for each combination of Spectrum Width and Sweep Time; bandwidth accuracy: individual bandwidths are calibrated within  $\pm 20\%$ , bandwidth repeatability and stability typically better than  $\pm 3\%$ .

**IF Gain Set:** 2-section attenuator provides 0 to 80 dB attenuation in 1-dB steps; one section provides 0 to 70 dB attenuation in 10-dB steps; the other 0 to 10 dB in 1-dB steps; IF Vernier provides continuous adjustment between 1-dB steps.

**IF Gain Set accuracy:** 70-dB section,  $\pm 0.5$  dB; 10-dB section,  $\pm 0.1$  dB.

**Sweep characteristics**

**Sweep time:** six calibrated rates from 3 msec/cm to 1 sec/cm in a 1, 3, 10 sequence; Vernier provides continuous adjustment between calibrated rates and extends slowest rate to at least 3 sec/cm.

**Sweep time accuracy:**  $\pm 3\%$ .

**Sweep synchronization:** internal: sweep free runs; line: sweep synchronized with power-line frequency; external: sweep synchronized with externally applied signal of +3 to +15 volts peak amplitude; BNC female input connector on rear panel; single sweep: sweep actuated by front panel pushbutton; panel light signifies duration of single sweep.

**External sweep:** input: 0 to +15 volt external signal (from 10 k ohm source impedance) results in full 10 cm CRT horizontal trace; BNC female connector on rear panel, direct-coupled; blanking: -5 volt external blanking signal required to blank retrace; BNC female connector on rear panel.

**General**

**Output signals:** vertical and horizontal signals applied to CRT are available for external applications; rear panel BNC female connectors; vertical: 0 to approximately -4 volts, open circuit, 4700 ohms source impedance; horizontal: 10 volts p-p  $\pm 0.3$  volt, open circuit, sweep approximately symmetrical about 0 volts, source impedance 4700 ohms; IF test point (20 MHz) also provided, rear panel BNC female connector.

**RFI:** conducted and radiated leakage limits are below those specified in MIL-I-6181D and MIL-I-16910C.

**Power:** 115 or 230 V  $\pm 10\%$ , 50 to 400 Hz, < 55 W.

**Dimensions:** 16 $\frac{3}{4}$ " wide, 7 $\frac{1}{4}$ " high, 18 $\frac{3}{8}$ " deep (425 x 185 x 467 mm); hardware furnished for rack mount 19" wide, 6-31/32" high, 16 $\frac{3}{8}$ " deep behind panel (483 x 177 x 416 mm).

**Weight:** net 41 lbs (18,5 kg); shipping 48 lbs (21,6 kg).

**Accessory items supplied:** rack mounting kit; joining bracket kit for mounting Model 851B on Model 8551B.

**Price:** Model 851B, \$2400.

**Options:**

07 P7 phosphor in lieu of P2 (amber filter supplied) n/c

31 P31 phosphor in lieu of P2 (green filter supplied) n/c

## PRESELECTOR; SPECTRUM ANALYZER

Add versatility in spectrum analysis  
Models 8441A; E01-851B



# ANALYZERS

### 8441A Preselector

HP 8441A is a voltage tunable bandpass filter designed primarily as a companion instrument for the 851B/8551B Spectrum Analyzer. The 8441A uses an yttrium-iron-garnet (YIG) current-tunable filter to pass a desired signal and reject others. By automatically tracking the analyzer tuning, it virtually eliminates multiple, image, and spurious responses, simplifying the display and making it easier to interpret. The 8441A also can be used as a manually tuned or voltage tuned narrow-band filter with a center frequency anywhere from 1.8 to 12.4 GHz. When internally swept, the 8441A plus a broad-band crystal detector and sensitive oscilloscope form a simple spectrum analyzer.

### Specifications, as preselector for 851B/8551B

**Frequency range:** 1.8 to 12.4 GHz.

**Insertion loss:** <5 dB (typically 2 swr) in the passband; signals outside the passband are reflected.

**Maximum input for <2 dB signal compression:** - 20 dBm, 1.8 to 2 GHz; + 10 dBm, 2 to 12.4 GHz.

**Absolute maximum input level:** + 30 dBm.

**Reduction in 8551B LO emission (LO emission is 2 to 4 GHz, typically 0 dBm):** 2 GHz IF input: 50 dB except when preselecting 2<sup>nd</sup> harmonic mixing mode from 2 to 4 GHz;

200 MHz IF input: 33 dB (1<sup>st</sup> harmonic mixing mode), 40 dB (1<sup>st</sup> harmonic mixing mode).

**Undesired response reduction:** at least 35 dB.

**Contribution to analyzer frequency response over 2 GHz range (add to analyzer frequency response):** ± 2.5 dB for fundamental mixing mode, ± 3.5 dB for second harmonic mixing mode, ± 4.5 dB for third harmonic mixing mode.

**Maximum sweep rate:** 10 msec/cm.

**Price:** HP 8441A, \$2950.

### E01-851B Spectrum analyzer

This analyzer is designed for the user working primarily in one waveguide band between 0.8 and 40 GHz, offering exceptional sensitivity and flat response in the selected band. It is extremely useful in applications such as radar spectrum analysis, leakage testing, frequency response measurement, and distortion analysis.

The E01-851B Spectrum Analyzer consists of three separate but mutually compatible instruments: The 851B Display Section, 8690A Sweep Oscillator, K10-8551B Converter Section. The 851B (described on the previous pages) provides this analyzer with excellent display characteristics. The 8690A (see Signal Sources) serves as the local oscillator (LO), and its RF Unit determines the frequency range. The particular RF Units supplied is determined by option; Options 01 through 07 include RF Units 8691A through 8697A respectively.

The K10-8551B Converter Section converts the input signal to the 20 MHz IF signal required by the Display Section. The Converter includes a wideband input mixer for viewing signals in coax plus a direct input to its 200 MHz first IF for use with an external waveguide mixer. (The K10-8551B and 851B can also be used with a signal generator as the LO to form a sensitive and stable fixed receiver)

Sensitivity of the E01-851B with 100-kHz bandwidth is -90 dBm through its coaxial range of 0.8 to 12.4 GHz. Frequency response is ± 3 dB per octave, ± 1.5 dB per 100 MHz. The coaxial input includes a high performance RF attenuator which provides up to 60 dB of attenuation in 10 dB steps.

For viewing signals in waveguide systems operating from 12.4 to 40 GHz, an external mixer, the HP 11517A, is used. Sensitivity ranges from -85 to -70 dBm with 100 kHz bandwidth. LO power is coupled to the external mixer through a waveguide directional coupler such as an HP 752, and the mixing products are supplied to the 200 MHz IF of the Converter section through a coaxial cable. Below 12.4 GHz, an HP 281A Waveguide-to-Coax Adapter permits connection of waveguide signals to the coaxial input.

While spectrum widths and tuning characteristics are determined by the LO, the observed signal is 200 MHz above or below the LO frequency due to the 200-MHz first IF. However, signal frequency can be determined exactly with the simple signal identifier which is push-button operated. The 8441A Preselector can be used to suppress image and harmonic responses. Price: HP E01-851B, \$7,125 to \$10,275, depending upon option selected. Price: HP K10-8551B only, \$1,600.

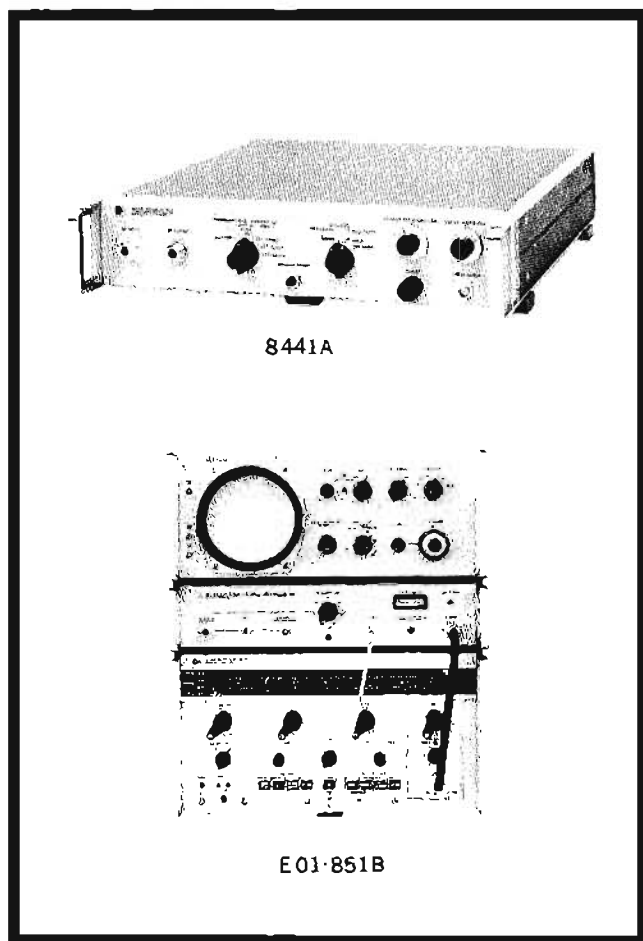

8441A

E01-851B



### Amplifiers

Amplifiers have two basic functions in instrumentation: (1) to amplify signals that are too low in level for intended applications, and (2) to isolate signal sources from other circuits.

No single amplifier has the bandwidth, gain, noise figure, stability and output capability required for every conceivable situation. Hewlett-Packard amplifiers are designed with the maximum number of applications in mind while minimizing cost.

HP amplifiers are divided into two groups: (1) ac amplifiers and (2) dc amplifiers.

### AC amplifiers

A typical general-purpose ac amplifier is the HP 465A. Designed to amplify low-level signals, it has a noise level of 25  $\mu$ V and a bandwidth of 1 MHz.

Low noise in the amplifier is achieved with a field-effect transistor (FET).

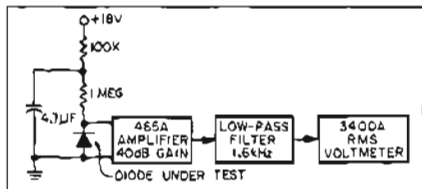

Figure 1. Wide dynamic range of the HP 465A General-Purpose Amplifier can be used for diode noise-measurement tests.

There are numerous applications for such a general-purpose ac amplifier. For example, production selection of diodes for a sampling gate according to their noise when reverse biased is accomplished with the simple test set-up, Figure 1. Measurements are made with an rms voltmeter to get true rms value of diode

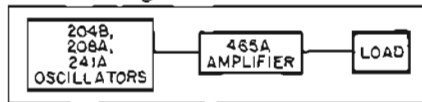

Figure 2. Output of low-power oscillators can be increased.

noise. Overall system noise of this scheme is 10  $\mu$ V. Acceptable diodes have noise voltages less than 20  $\mu$ V. The same test set-up, with appropriate filter and proper shielding, could be used to measure transistor noise to a level as low as 2  $\mu$ V.

This solid-state amplifier is ideal for increasing the power output of transistorized oscillators or amplifiers. Output power of HP oscillators can be increased 14 times into a 600  $\Omega$  load with the amplifier, or by a factor of 180 into a 50  $\Omega$  load, Figure 2. The amplifier may also be used as an impedance converter.

Low output impedance of the 465A

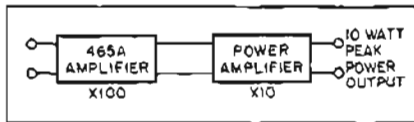

Figure 3. Cascading the HP 467A Power Amplifier with the HP 465A Amplifier results in a stable 60 dB amplifier with 10 M $\Omega$  input impedance and 10 W peak-power output.

Amplifier is advantageous for driving several loads simultaneously, or for driving long cables. The amplifier has been used as a distribution amplifier to supply a precision 100 kHz time base simultaneously to several counters.

When the 465A Amplifier is cascaded with the HP Model 467A Power Amplifier, Figure 3, the combination achieves 10 W peak-power output, an overall stable gain of 60 dB, a 1 MHz frequency response, and the low-noise, high-impedance input of the amplifier.

The HP 467A Power Amplifier has an average ac power capability of 5 W over a frequency range from dc to beyond 1 MHz; and peak power of 10 W output. It has an output impedance that is virtually zero (<0.005  $\Omega$  in series with 1  $\mu$ H); and it is able to drive practically any load impedance within its 40 V and 1 A peak-to-peak ratings.

The 467A also serves as a power supply with a variable control that can provide maximum-negative to maximum-positive volts. The output voltage polarity may thus be changed without switching or lead changing, a useful feature in semi-conductor diode testing, where both reverse and forward bias are required.

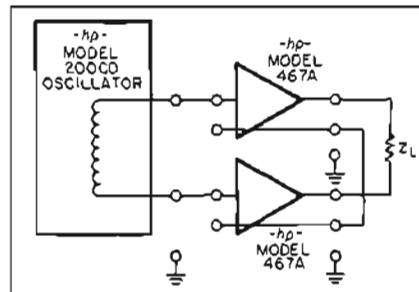

Figure 4. Use of two power amplifiers in push-pull configuration doubles available output voltage.

Fast step-response and 500 mA current output enables the 467A to drive magnetic cores or tape recorder heads directly. It may also be used to power incandescent lamps, or, with the aid of a step-up transformer, neon lamps to provide excitation for photo-diodes or photoconductors. Since full power is available up to 1 MHz, the new amplifier can also function

as a radio-frequency transmitter or as a driver for ultrasonic transducers.

If signals >40 V peak-to-peak are needed, two power amplifiers, driven from a differential source such as the HP Model 2000C Oscillator, may be connected in push-pull (Figure 4). This combination will develop 80 V peak-to-peak at 1 ampere.

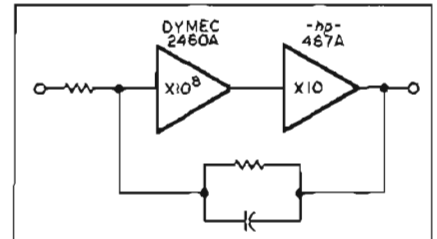

Fig. 5. Use of cascaded high-gain operational amplifier and power amplifier achieves operational power amplifier of high stability.

Such an amplifier may also be considered a programmable power supply.  $\pm 2$  V across the input terminals (which draw  $\pm 40 \mu$ A) is sufficient to yield full output. Because of the device's inherently wide bandwidth, transient recovery time for a  $1/2$  A current change is less than 50  $\mu$ s.

An operational amplifier of exceptional characteristics can be formed by combining the 467A power amplifier in an operational loop with the Dymec Model 2460A dc Operational Amplifier (Figure 5). With this combination, the power capabilities of the Model 467A are combined with the low drift and high gain of the Dymec 2460A to make an operational amplifier of exceptional characteristics. Add a dc motor to the above combination and it forms a complete servo system.

### Precision ac amplifier

Recently introduced, the HP 463A is a precision, all solid-state amplifier delivering 100 V rms at 5 W. Augmenting these features is the ultra-low distortion specification and three fixed-gain ranges (10, 100 and 1000) with a continuously adjustable gain capability from 0 to 1000.

The 463A is valuable not only in precision measurements and calibration schemes, but as a general-purpose amplifier. It is ideal to amplify the output of the most stable solid-state oscillators, or to isolate thermocouple transfer measurements. It is entirely suitable as a preamplifier for precision ac voltmeters, whether digital (HP 3440A/3445A) or other (e.g., 741B Differential Voltmeter).

Sensitivities of digital ac or dc volt-

meters can be extended while maintaining useful accuracy.

Combining the HP 463A with the HP 3445A or 3446A AC-to-DC Converter in the 3440A Digital Voltmeter increases the sensitivity of either plug-in from 10 V full scale to as low as 10 mV full scale over a frequency range of 50 Hz to 100 kHz. Because the HP 463A is a direct-coupled amplifier, it can also be used to increase the dc sensitivity of most digital voltmeters.

### High-frequency ac amplifiers

The HP Models 461A and 462A Amplifiers use five cascaded stages to obtain wide bandwidth plus input and output emitter-followers to match 50  $\Omega$  coaxial lines. The 461A frequency response ex-

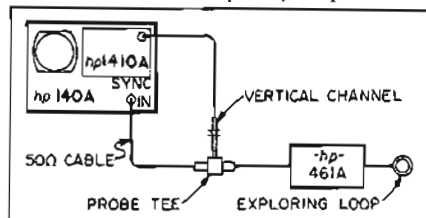

Figure 6. Block diagram shows use of amplifier with search coil and oscilloscope to probe for RF radiation sources.

tends to 150 MHz. The 462A is rolled off along a Gaussian curve to preserve the waveshapes of complex waveforms.

Sources of radio frequency interference generated by high-frequency or fast-pulse circuits can be located and identified by combining the HP Model 140A/1410A/1425A Sampling Oscilloscope with a 461A/462A Amplifier. An exploring loop of two or three turns of wire attached to the amplifier input cable serves as a convenient probe. The amplifier provides sufficient gain to drive the sync input of the sampling scope while feeding one of the scope input channels through a probe tee on the amplifier output cable, as shown in Figure 6.

Measurements of the noise figure of individual low-level circuits still in the breadboard stage are possible with the 461A as a preamplifier for the HP Models 340B and 342A Noise Figure Meters (the noise figure meters were designed to work at the output of complete IF strips that have 40 dB or more gain).

The 50  $\Omega$  impedance of the 461A/462A Amplifiers is well-matched for use with the HP 355 Series attenuators when incremental levels of stable gain are desired along with broadband performances.

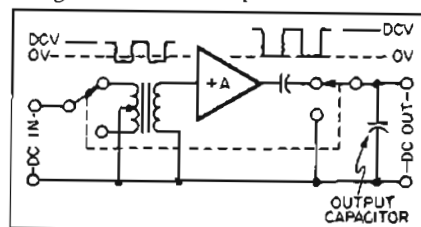

Figure 7. Modulated amplifier.

### DC amplifiers

A widely-used technique for circumventing the drift problems of direct-coupled amplifiers is to convert the dc to an equivalent ac (modulation). The ac is amplified in a gain-stable ac amplifier and reconverted to dc (demodulation). During amplification, the signal is represented by the difference between the maximum and minimum excursions of the ac waveform and is not affected by drift in the absolute voltage levels within the amplifier.

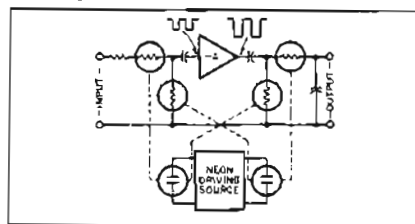

Figure 8. Amplifier with photoconductive modulator.

One method to convert the dc to ac is to switch the amplifier input alternately to both sides of a transformer, as shown in Figure 7. This periodically inverts the polarity of the signal applied to the amplifier. The switches illustrated may be mechanical, transistor or photoconductive. Another pair of contacts at the output establishes the ground level for a storage capacitor in series with the output. The output storage capacitor becomes charged to a level corresponding to the amplitude of the output square wave. Synchronous detection preserves the polarity of the input voltage and recovers both positive and negative voltages with the correct polarity.

DC amplifiers just described offer drift-free amplification of low-level signals in the microvolt region. Another modulation technique uses two photoconductors—one in series with, and one parallel to the amplifier input, shown in Figure 8.

Photoconductors' resistance is proportional to their illumination. By illuminating the photoconductors alternately, the amplifier input is connected to the signal and to ground. Photoconductors perform well as modulators at microvolt levels. They can be isolated from the driving signal and designed with very low offset voltages.

### Wideband dc amplifiers

Use of a modulator in a dc amplifier limits its frequency response. A common modulation frequency is 400 Hz for bandwidths approaching 100 Hz.

Another technique to obtain dc-stable, wideband response is to use a modulator-amplifier to correct for dc drift in a wideband, direct-coupled amplifier, as in the DY-2460A. The amplified signal is reduced in a divider network by the same amount it was amplified and compared with the original input signal at the

summing point. The difference, caused by drift, is amplified through a modulated amplifier and applied to the direct-coupled amplifier to cancel the drift. (This is sometimes called a "chopper-stabilized" amplifier.)

### Differential amplifiers

Differential data amplifiers have two identical input channels that function in push-pull fashion. The output generally is single-ended and represents the amplified difference between the two input channels. This arrangement cancels hum or other interference picked up on the signal leads which appear in phase to the amplifier inputs (referred to as common-mode signals). Examples are the HP Models 2470A and 8875A (pages 403-405).

Since a differential amplifier is sensitive only to the difference between the two input signals, the transducer or other signal source need not be grounded. Therefore, differential amplifiers allow a bridge-type transducer to be used with a grounded power supply.

The differential amplifier configuration

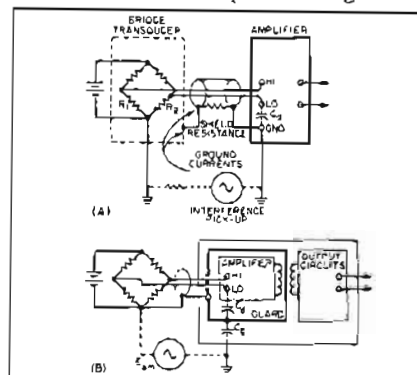

Figure 9. Guard reduces capacitance between signal leads and ground.

also allows injection of a fixed dc voltage into either channel to permit establishment of a new voltage-reference level at the output (zero suppression).

When the input is floating, cable shielding may be connected to chassis ground rather than to signal ground. However, both ac and dc potentials can exist between two widely-separated earth grounds, and common-mode currents may circulate. The signal leads and the internal capacitances are shown lumped as  $C_a$  in Figure 9. Consequently, a ground loop may inject interference into the signal path. A guard shield (Figure 9) providing an electrostatic shield around the input circuitry breaks the stray capacitance into two series capacitances,  $C_a$  and  $C_b$ . A much higher impedance is then presented to the flow of common-mode signals. This type is termed a floated and guarded amplifier.

DC amplifiers using choppers are able to couple the signal information out of the guard shield by means of transformers. No dc connection between the output



and input grounds is necessary; and no ground loops are formed between the input circuits and equipment connected to the output.

Amplifiers designed for use with guarded digital voltmeters or other guarded equipment (Models 2411A and 860-4300) continue the guard shield through the output.

**Selecting an amplifier**

Stability, noise and input-output impedances, as well as cost, are basic considerations. If an amplifier is to be used for general-purpose applications, low distortion and preservation of magnitude relations are essential. When selecting an amplifier for pulse applications, low rise times and low sag are of prime importance. A differential amplifier is indicated for elimination of ground loops formed between input circuits and equipment connected to the output. The differential amplifier also is the most logical choice when interference from other connecting equipment is likely. To preserve guarding features of voltmeters or other connecting equipment, or to suppress common-mode noise, a floated and guarded amplifier is essential.

All the Hewlett-Packard amplifiers described have been designed with the requirements of a maximum number of applications in mind. Each category of amplifier uses a different method to maximize performance over a specific group of applications while minimizing cost. A Hewlett-Packard amplifier is available to meet your specific requirements. Refer to Figure 10 for relative functions and features. The extensive amplifier line of Hewlett-Packard Sanborn Division, comprising a wide variety of general-purpose and specialized types, is described on pages 404, 405 and 406.

**Microwave amplifiers**

There often are applications requiring high-quality microwave signals, such as those obtained from precision signal generators, where the magnitude of signal power needed is greater than that available directly from the signal generator. Amplification of the signal generator output will fill this requirement; at frequencies from 1 to 12.4 GHz this is accomplished by HP microwave amplifiers. Four broadband amplifiers are available, each using a traveling-wave tube that delivers at least one watt output with one milliwatt or less input. Excellent stability is achieved through the use of highly regulated power supplies for all elements of the TWT, including the filament. The amplifiers have provision for amplitude modulation and since the internal modulation amplifier is dc-coupled, remote programming and power leveling are possible. Sensitivity is high for large output power changes from relatively small modulation signals, obviating the need for an external modulation amplifier.

**Figure 10**  
**Hewlett-Packard Amplifiers**

**General-purpose amplifiers**

Frequency response	Input Z	Gain	Noise (max)	Output (max)	Model	See Page
5 Hz-2 MHz ( $\approx 1$ dB)	1 M $\Omega$ / 15 pF	40, 20 dB	250 $\mu$ V referred to input	10 V into 3000 $\Omega$	450A	408
1 kHz-150 MHz ( $\approx 1$ dB)	50 $\Omega$	40, 20 dB	< 40 $\mu$ V at 40 dB	0.5 V rms into 50 $\Omega$	461A	411
100 Hz-50 kHz ( $\approx 0.1$ dB) < 2 dB down at 5 Hz and 1 MHz	10 M $\Omega$ / < 20 pF	40, 20 dB	< 25 $\mu$ V referred to input	< 5 V rms into 50 $\Omega$	465A	409
10 Hz-1 MHz ( $\approx 0.5$ dB)	1 M $\Omega$ / 25 pF	40, 20 dB	75 $\mu$ V rms	1.5 V rms into 1500 $\Omega$	466A (battery operated)	408
dc-1 MHz (< 0.001 dB dc-10 kHz) Precision amplifier, ultra-low distortion	1 M $\Omega$ / < 35 pF	60, 20, 40 dB	50 $\mu$ V-1.5 mV referred to input (depends on range)	100 V rms to 50 mA into 2 k $\Omega$	463A	412

**Power and voltage amplifiers**

Instrument	Frequency response	Gain	Output	Model	See Page
Power amplifier is also $\approx 1$ V to $\approx 20$ V $\frac{1}{2}$ amp power supply, input Z 50 k $\Omega$ /100 pF, noise < 5 mV p-p.	dc-1 MHz ( $\approx 1\%$ )	X1, X2, X5, X10	20 V peak-0.5 A peak	467A	409
Tunable Power Amplifier, source of high-level rf power when used with signal generators.	10-500 MHz	30, 27, 24 dB, depending on frequency	0-15 V into 50 $\Omega$	230A	413
Microwave power amplifiers; TWT devices; amplitude modulation capability with internal 20 dB, 500 kHz modulation amplifier.	1-2 GHz	30 dB	1 W	489A	414
	2-4 GHz	30 dB	1 W	491C	414
	4-8 GHz	30 dB	1 W	493A	414
	7-12.4 GHz	30 dB	1 W	495A	414

**Fast-pulse amplifiers**

Rise time	Input Z	Gain	Noise (max)	Output	Model	See Page
3 ns	200 $\Omega$	20 dB into 200 $\Omega$	< 10 dB	+3.2 V -8 V into 300 $\Omega$	460AR	410
3 ns	200 $\Omega$	15 dB into 200 $\Omega$	< 6 dB	+4 V, -60 V into 200 $\Omega$	460BR	410
< 4 ns	50 $\Omega$	40, 20 dB	40 $\mu$ V at 40 dB	1 V p-p into 50 $\Omega$	462A	411

**Operational amplifiers**

Instrument	Frequency response	Gain	Output	Model	See Page
Operational amplifier, uses one of four plug-ins below to suit it for specific applications: < 4 $\mu$ V p-p noise.	depends on plug-in; gain-bandwidth product approx. 10 <sup>6</sup> Hz	5 x 10 <sup>7</sup> mA at dc (open loop)	10 V,	2460A	407
2460A Plug-ins	Data systems unit	350 Hz-25 kHz	10, 30, 100, 300, 1000; inverting	2461A-M1	407
	Bench-use unit	350 Hz-50 kHz	1, 10, 100, 1000; inverting +11 to 1 Vernier	2461A-M2	407
	Plus-one gain unit	300 kHz	X1, non-inverting	2461A-M4	407
	Patch unit	Brings input, output, summing point to front panel to perform analog operations.		2461A-M3	407

**Data amplifiers**

Instrument	Frequency response	Gain	Noise (max)	Output	Model	See Page
Differential data amplifier (with internal power supply)	dc-50 kHz	10, 30, 100, 300, 1000	5 $\mu$ V rms rti	$\approx 10$ V	2470A	403
Differential data amplifier (with internal power supply)	dc-75 kHz	1-1000	5 $\mu$ V rms rti	$\approx 10$ V	8875A	405
Narrowband differential amplifier	dc-100 Hz	1000	3 $\mu$ V p-p	$\approx 5$ V	860-4300	404

Specialized guarded amplifiers, for use with guarded digital voltmeters, are discussed on pages 227 and 230.



## DATA AMPLIFIER

Solid-state, wideband differential amplifier  
Model 2470A



## AMPLIFIERS

The HP 2470A Amplifier is a flexible wideband differential amplifier exhibiting low drift and noise, achieved without the use of a chopper. The instrument will supply up to 1 watt output to a resistive or reactive load. Exceptionally high reliability and accuracy are achieved by the use of silicon semiconductors.

Applications include amplification of strain gage bridge, thermocouple and other low-impedance sensors. Amplifier provides an output suitable for data acquisition devices, in-

cluding recording galvanometers and oscillographs, analog recorders, servo control systems. Low instrument cost keeps per-channel price to the minimum. The 2470A also applies directly to many general-purpose laboratory uses, both differential and single-ended.

The amplifier with its power supply is packaged in a unique molded dielectric case, so compact that ten instruments fit side-by-side in 5¼" of standard 19" rack space.

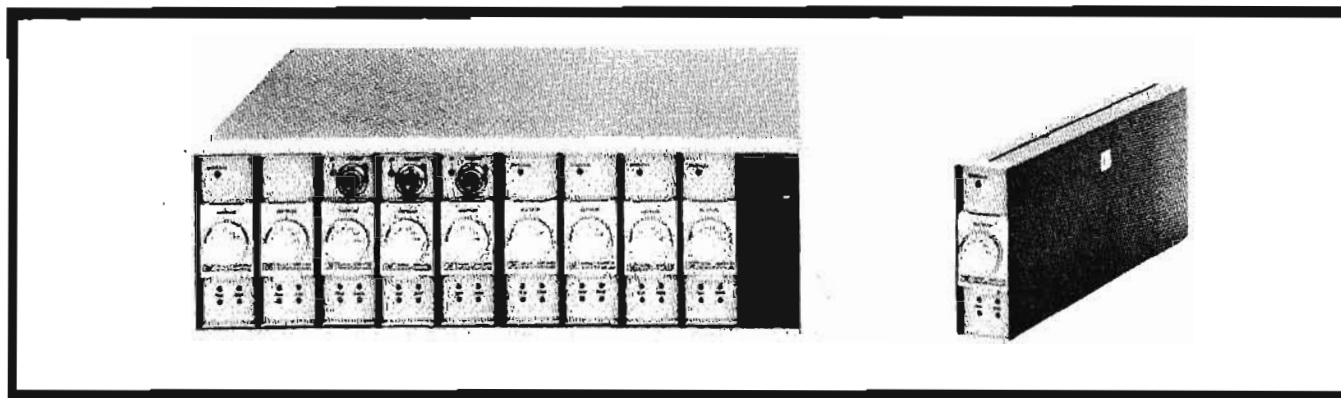

### Specifications

(unless noted, specifications hold after 30 min. warm-up at 25°C ambient, 1 K ohm source resistance, any unbalance)

**DC gain:** fixed steps: X0 (output shorted), X10, X30, X100, X300, X1000; optionally X0, X1, X10, X100, X1000, or other steps between 1 and 1000 available, up to 6 positions.

**Gain accuracy (no load):** at 25°C, ±0.02% initially ±0.005% per month stability; ±0.001% per °C maximum temperature coefficient.

**Vernier adjustment (optional):** ±1% trimpot, ±0.01% resolution; or X1 to X3.5 multiplier with dial calibrated to ±3% accuracy.

**DC linearity:** 0.002% at gain of 1000, 0 to ±10 V output.  
**Input impedance:** 10<sup>6</sup> ohms min., shunted by 0.001 pF max.

**Zero stability (at constant 25°C):** ±5 μV, ±0.5 nA per day referred to input; ±20 μV per day referred to output; ±1 μV/°C, ±0.5 nA per °C referred to input; ±10 μV/°C referred to output.

**Noise:** 0 to 100 Hz: 3 μV p-p referred to input; +30 μV p-p referred to output; to 50 kHz: 5 μV rms, referred to input; +500 μV rms referred to output.

**Common mode rejection:** 120 dB to 60 Hz.

**Maximum input signal:** ±11 V, differential + common mode; up to ±20 V can be handled without damage to instrument.

**Output:** ±10 V, 0 to 100 mA; self-limits at approx. 11 V, 125 mA.

**Output impedance:** 0.1 ohm in series with +10 μH maximum.

**Load capability:** 100 ohms or 0.01 μF for full output; amplifier is stable and undamaged by short circuit or any capacitive load.

**Slewing:** 10<sup>7</sup> V/sec referred to output, or 10<sup>9</sup> V/sec referred to input.

**Bandwidth:** ±1 dB, 0 to 10 kHz, any gain step; ±3 dB 0 to 50 kHz any gain step; other fixed 3 dB bandwidths between 0 to 50 kHz and 0 to 100 Hz optionally available.

**Settling time:** 100 μsec to within 0.01% of final value.

**Overload recovery:** settling time +100 μsec for inputs (signal plus common mode) up to 10 times full scale; less than 1 msec for inputs up to 20 V.

**Overload signal (optional):** output is -23 to -31 V without overload; 0 to -1 V with overload, 5 mA drive capability; also, front-panel indication.

**Operating conditions:** 0 to 55°C ambient temperature range; up to 95% relative humidity at 40°C.

**Power:** 115 or 230 V ±10%, 50 to 400 Hz, approx. 10 W max.

**Dimensions:** 1-9/16" wide, 4 7/8" high, 15" deep (39.7 x 123.9 x 381 mm).

**Weight:** net 4 lbs (1.8 kg); shipping 6 lbs (2.9 kg).

**Accessories available:** mating rear connector with power cord, input/output cables; combining case: contains up to 10 instruments in 5¼" of standard 19" rack space (mating connectors furnished with amplifier); bench stand: holds one amplifier upright and includes input/output connectors, power switch, pilot light, power cord.

**Optional modifications:** 1% gain trim; 3.5 to 1 gain vernier; overload indicator with output signal; special gain steps.

**Price:** HP 2470A Data Amplifier, \$585.

## AMPLIFIERS



## DIFFERENTIAL AMPLIFIER

Wideband amplifier for data acquisition systems  
Model 8875A

### Features

- Bandwidth:** dc to 75 kHz.
- Common mode rejection:** 120 dB, dc to 60 Hz at  $k = 1000$ .
- Common mode voltage tolerance:** 40 V p-p.
- Gain:** 1 to 1000 in seven fixed steps with vernier control for up to 3.3:1 gain increase.
- Gain stability:** .01% for 30 days.
- Non-linearity:** .01% of full scale (zero based).
- Output:**  $\pm 10$  V,  $\pm 100$  mA.
- Floating input:** no dc path to ground needed. 10 amplifiers fit in 5" high x 19" wide (127 x 482 mm) modular cabinet for bench or rack mounting.
- Optional features include dual outputs and bandwidth restriction to 2 Hz.

The 8875A is a differential wideband, dc amplifier for use with modern data acquisition systems employing such devices as digital voltmeters, digital printers, analog digital converters, magnetic data recorders, oscillographs and other readout instrumentation. It is packaged for use as a single-channel amplifier as well as for multi-channel use in 19-inch wide (482 mm) 10-unit banks.

Design characteristics of the Model 8875A make it particularly suitable for amplifying very low level signals such as those derived from thermocouples, dc excited strain gages, dc excited vibration sensors and similar transducers. Specific areas of application include space vehicle checkout, checkout at missile and rocket test stands, wind tunnel testing, ship and aircraft vibration studies and other applications which require the continuous measurement of minute changes of such variables as temperature, humidity, vibration, force, strain, flow, pressure, etc. Other applications include arrangements with either input or output multiplexers.

The Model 8875A is a completely solid-state amplifier. It offers high gain (1-1000) with vernier control for variable settings between fixed steps, high rejection of common mode signals, and extremely accurate amplification of low level signals in the presence of noise. Since no chopper is used, complete freedom is obtained from intermodulation distortion caused by signals having harmonics in the vicinity of the chopper frequency.

Each 8875A Amplifier includes an integral power supply and measures only 4 $\frac{3}{4}$ " high x 1-9/16" wide x 15" deep (121 x 27 x 381 mm). For multiple channel usage, ten 8875A's are accommodated in a 5" x 19" (127 x 482 mm) Hewlett-Packard Combining Case, Model 1069-01A. This modular cabinet contains input and output connections, power cable, on-off switch, cooling, fuse and mating connectors for the ten amplifiers. The modules can be stacked or can be equipped with tilt stands for bench top use. Standard accessories include flanges for rack mounting the entire module.

Plug-in circuit boards, which are used in the construction of the amplifier, make for ease and speed of servicing. When used individually, the completely enclosed amplifier requires no cooling. Built-in cooling in each 10-unit module makes for long life in densely packed, multi-channel installations.

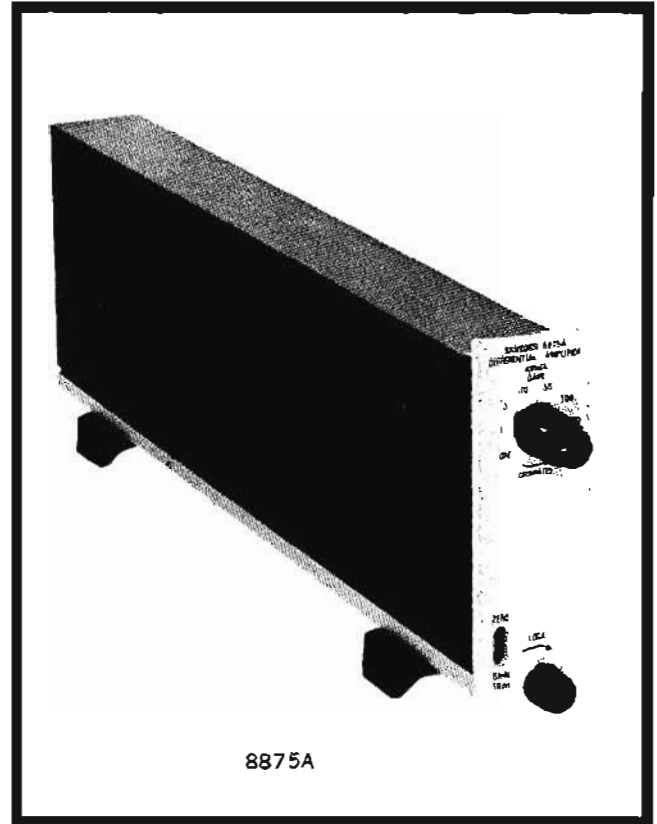

8875A

### Specifications

- Bandwidth:** dc to 75 kHz within 3 dB. Can be changed by addition of a capacitor; 3 dB points down to 2 Hz can be obtained.
- Gain:** range is from 1 to 1000 in seven fixed steps of 1, 3, 10, 30, 100, 300, and 1000, plus an OFF position.
- Gain accuracy:**  $\pm 0.1\%$ .
- Gain stability:**  $\pm 0.01\%$  at constant ambient temperature for 30 days,  $\pm 0.005\%/^{\circ}\text{C}$  (for fixed gain steps only).
- Gain adjustment:** gain control covers a  $\pm 3\%$  range with sufficient resolution for setting any one gain to  $\pm 0.01\%$ . A vernier control can be switched in for setting the gain to any desired value between the standard fixed steps. Stability of this control is approximately 2% over a 0-55 $^{\circ}\text{C}$  temperature range. This control increases the gain. When it is in its extreme position (gain change at maximum) the bandwidth drops to 30 kHz (3 dB point).
- Input circuit:** balanced differential; may be used single-ended. Will accept floating signal sources without requirement for return path to ground.
- Differential Input Impedance:** 20 M $\Omega$ ,  $< 0.001 \mu\text{F}$  shunt.
- Common mode rejection:** at least 120 dB from dc to 60 Hz for up to 500 ohms source impedance in either side of input circuit at gain of 1000; 66 dB min. at gain of 1.

**Guarded common mode input impedance:** 2000 MΩ, < 2pF shunt.

**Common mode tolerance:** ±20 volts.

**Input overload tolerance:** ±30 volts differential; ±70 volts common mode will not damage the amplifier.

**Output circuit:** ±10 volts across 100 ohms. (100 mA) and 0.2 ohms max. output impedance at dc. Short circuit proof. Current limited to approximately 150 mA. Will not oscillate with any value of capacity load. Magnitude of capacity load is governed only by output capability of amplifier.

**Drift:** ±3 μV referred to input, ±0.2 mV referred to output at constant ambient temperature for 30 days; ±1 μV/°C referred to input, ±0.2 mV/°C referred to output.

**Noise:** measured with respect to input with 1 kΩ signal source impedance at gain of 1000. Noise measurements with respect to input are:

Bandwidth	Noise
dc - 10 Hz	1 microvolt peak to peak
dc - 100 Hz	3 microvolts peak to peak
dc - 1 kHz	6 microvolts peak to peak
dc - 10 kHz	3 microvolts rms
dc - 50 kHz	4 microvolts rms
dc - 250 kHz	5 microvolts rms

**Non-linearity:** less than 0.01% of full scale value, 10 volts (zero based).

**Current feed to source:** 10<sup>-9</sup> A max. at constant ambient temperature, ±10<sup>-9</sup> A/°C.

**Settling time:** 100 μsec to 99.9% of final value for a step input.

**Overload recovery time:** recovers to within 10 μV referred to input plus 10 mV referred to input in 10 ms for a differential overload signal of ±10 V at gains of 300 to 1000, and 1 ms at gains of 1 to 100. For a 10 times full scale overload of any duration: 2 ms for gains of 300 to 1000 and 100 μsec for gains of 1-100.

**OUTPUT CAPABILITY VS. FREQUENCY**  
(LOAD 100 OHMS OR GREATER)

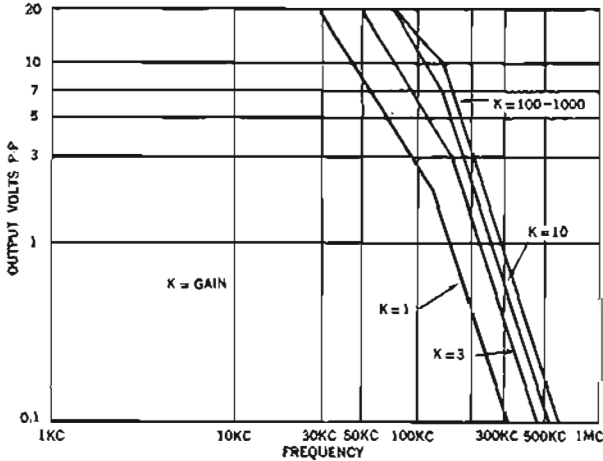

**Performance as a function of line voltage:** for line variations of 115 V ±10%, the output zero remains within ±2 mV and the gain remains within ±0.01%.

**Slewing:** output circuit: with resistive load of 100 ohms or greater, 10<sup>6</sup> V/sec for 10 mV shift in dc output. Input circuit: gain of 1, 2.5 x 10<sup>6</sup> V/sec for 10 mV shift in dc output; gain of 3, 0.83 x 10<sup>6</sup> V/sec for 10 mV shift in dc output. For gains greater than 3, output circuit determines slewing rates.

**Input-output isolation:** 2000 MΩ shunted by 2pF.

**Temp. range:** 0°C - 55°C.

**Controls:** Front Panel: Gain, Gain Trim, Gain Vernier with Switch, Zero Trim.

**Internal:** control for setting current feedback to source to < 10<sup>-9</sup> A. Balance control.

**Connections:** signal and power from rear.

**Power:** 115/230 V ±10%, 50-400 Hz, 6 W.

**Dimensions:** 4 3/4" high, 1-9/16" wide, 15" deep (121 x 40 x 381 mm).

**Weight:** 3.5 lbs (1,6 kg).

**Prices:** Model 8875A Differential Amplifier, \$495.

**Option 01:** dual outputs: ±10 V at ±100 mA; ±10 V at ±10 mA; a short on one output will have negligible effect on the other output, add \$75; **Option 02:** bandwidth restriction filter. A front panel rotary switch provides selection of four discrete cut-off frequencies plus a full bandwidth (75 kHz) position. The four frequencies are 2, 200, 2000 and 20,000 Hz. Amplifier bandwidth is approx. 3 dB down at the cutoff frequency with a 12 dB/octave roll-off. (Other frequencies available on special order, add \$75; Options 01 and 02 may be combined in one amplifier. This combination is specified as Option 05.) This configuration will provide the filtering on the LOW power (10 mA) output only. (Filtering on either or both outputs available on special order.) **Option 03:** gain range from 10 to 1000 in seven fixed steps of 10, 20, 50, 100, 200, 500 and 1000, plus an "OFF" position. No additional cost. **Option 04:** Model 14010A Cord Connector Set, \$25; **Option 05:** \$365; **Accessory:** Model 01069-61060 Blank Panel Assembly, \$5.

**NOISE VS. GAIN**

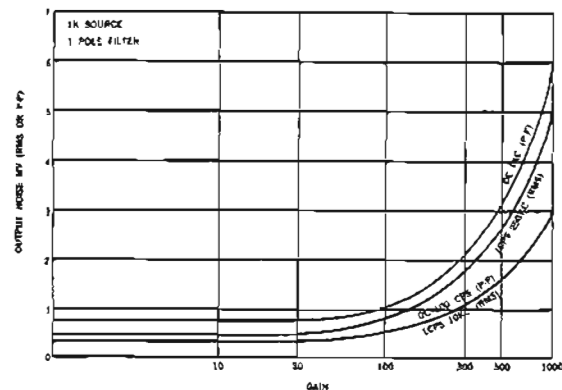

## AMPLIFIERS



## DIFFERENTIAL AMPLIFIERS

Low-level amplification of low-level signals  
Model 860-4300

### 860-4300 Narrow-Band Differential DC Amplifier

Model 860-4300 is designed to amplify low-level signals from thermocouples, strain gages and other resistance bridge transducers. This completely solid-state, low noise amplifier successfully combines a floating input which allows measurement of low-level signals even though complicated by ground loops, high gain and zero stability; and a floating output (isolated from input) which eliminates ground loop problems with terminal equipment. Typical outputs for these data amplifiers include digital voltmeters, tape recorders, oscillographs, oscilloscopes and other read-out devices.

These amplifiers also are offered in convenient 2- and 8-unit modules for rack mounting, and as an individual amplifier in a portable case. Power supplies are included.

### Specifications,\* 860-4300

**Gain:** 1000, 500, 200, 100, 50, 20, 10 and off; accuracy:  $\pm 0.5\%$  at dc; stability:  $\pm 0.05\%$  at dc with constant ambient temperature for 40 hours;  $\pm 0.005\%$  change/ $^{\circ}\text{C}$ ; trim: any gain setting can be trimmed to within  $\pm 0.02\%$ , covers  $\pm 3\%$  range.

**Input:** isolated from ground and from output; impedance: 1 megohm minimum, independent of gain.

**Common mode rejection:** (for 1000 ohms in either input lead) 130 dB at 60 Hz; 160 dB at dc.

**Common mode tolerance:** 220 V rms.

**Bandwidth:** dc to  $\pm 1\%$  at 30 Hz; dc to 3 dB down at 100 Hz.

**Rise time:** 20 ms to 0.1% of final value for a step input.

**Output:** isolated from input and from ground; impedance: 75 ohms.

**Output capability:**  $\pm 5$  volts at 2.5 mA. Amplifier is internally loaded with 2 k in parallel with 25 ufd. Any part, or all, or this load may be removed and connected externally.

**Linearity:**  $\pm 0.05\%$ ; ( $\pm 0.03\%$  for 0 to +5 V or 0 to -5 V).

**Drift:**  $\pm 2 \mu\text{V}$  at constant ambient temperature for 40 hours;  $\pm 0.2 \mu\text{V}/^{\circ}\text{C}$  referred to input,  $\pm 0.1 \text{ mV}$  at constant ambient for 40 hours;  $\pm 0.05 \text{ mV}/^{\circ}\text{C}$  referred to output.

**Zero trim:**  $\pm 50 \text{ mV}$  at output.

**Overload recovery:** 200 msec from  $\pm 10 \text{ V}$  overload; differential input voltages of  $\pm 60 \text{ V}$  peak will not damage input circuitry or chopper. Protection to higher voltages possible.

**Noise:** 3  $\mu\text{V}$  p-p referred to input for gain of 1000 (wideband).

**Ripple:** (peak, due to signal) 0.04% of signal.

### General specifications

**Power:** 115 V  $\pm 10\%$ , 50 to 400 Hz; 860-4300 approx. 5 watts;

\*Specifications are for source impedances of 1000 ohms and ambient temperatures from 15 $^{\circ}\text{C}$  to 45 $^{\circ}\text{C}$ . Rate of ambient temperature variation not to exceed 10 $^{\circ}\text{C}/\text{hour}$ . Amplifier will operate with higher source impedances. Performance degradation will be in gain accuracy, noise specification and temperature coefficient of gain. Amplifier will operate in ambients to 60 $^{\circ}\text{C}$ . In range above 45 $^{\circ}\text{C}$ , temperature coefficient of gain will increase to  $\pm 0.01\%/^{\circ}\text{C}$  when used with source impedance from 0 to 1000 ohms.

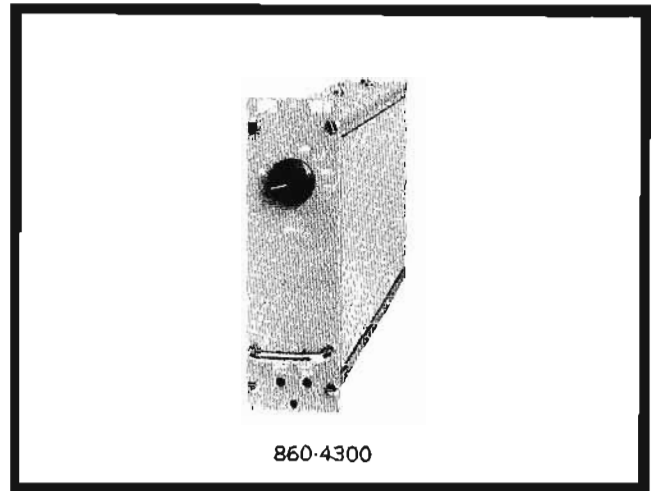

860-4300

**Dimensions:** 7" high, 2" wide, 14.9" deep (178 x 51 x 379 mm); 8800-02A, (8-channel rack mounts and power supplies) 7" high, 19" wide, 20-55/64" deep (178 x 483 x 530 mm); 860-200 (2-channel extended-front module): 3 1/2" high, 19" wide, 19 1/8" deep (89 x 484 x 186 mm); 860-1400 (1-channel portable case): 8 3/4" high, 3 1/4" wide, 21 7/8" long (222 x 83 x 556 mm).

**Weight:** 860-4300: net 5 lbs (2.3 kg), shipping 12 lbs (5.4 kg); 8800-02A (power supplies): net 26 lbs (11.8 kg), shipping, 35 lbs (15.8 kg); 860-200 (2-channel modules): net 10 lbs (4.6 kg), shipping 25 lbs (11.5 kg); 860-1400 (1-channel portable case): net 25 lbs (11.5 kg); shipping 35 lbs (15.9 kg).

**Prices:** Model 860-500A, \$225 (1-channel power supply); Model 860-4300, \$625 (8-channel power supply); Model 860-500A, \$210 (1-channel power supply).

**Accessory prices:** Model 860-1400, \$100 (1-channel portable case); Model 860-200, \$115 (2-channel module, extended front).

### Other versions of 860-4300

Narrower bandwidths, lower output impedance, higher output, lower drift and other added capabilities listed below are readily available in other versions of Model 860-4300. Contact your Hewlett-Packard sales office for complete information.

**Output impedance:**  $< 0.5$  ohms. When used with Model 8800-02A power supply, the low output side of all channels are connected together but not to ground; output connection does not ordinarily introduce objectionable noise; when used with commutators, as in multi-channel data acquisition systems, the output noise introduced will be negligible.

**Output capabilities:**  $\pm 5 \text{ V}$  at  $\pm 5 \text{ mA}$  to  $\pm 10 \text{ V}$  at  $\pm 100 \text{ mA}$ .

**Dual-output provisions:** two 5 mA, or one 5 mA and one 100 mA.

**Frequency response:** plug-in filters with 12 dB/octave roll-off provide cutoff frequencies to 4 Hz (smooths out noisy signals).

**Linearity:**  $\pm 0.05\%$  of 5 V output (terminal).

**Drift:**  $\pm 1 \mu\text{V}$  at constant ambient temperature for 40 hours.

# OPERATIONAL AMPLIFIER

High-gain amplifier with plug-in versatility  
Model 2460A; 2461A Plug-ins



## AMPLIFIERS

### Advantages:

- Photoconductive chopper, all-transistor circuitry for maximum reliability
- Fast settling time, rapid overload recovery for systems applications
- Low zero drift—less than  $1 \mu\text{V}$  per week
- Low noise—less than  $4 \mu\text{V}$  peak-to-peak

The wideband solid-state 2460A Amplifier, moderately priced for exceptional value, achieves extremely high reliability on low-level measurements through a specially designed photo-conductive chopper and all solid-state circuitry. Interchangeable plug-in units contain gain control circuits.

### Specifications, 2460A

(without plug-in)

**Open-loop gain (Inverting):** (minimum values with load impedance  $>1 \text{ k}$ )  $5 \times 10^4$  at dc;  $7 \times 10^3$  at 40 Hz, 1 at 1 MHz.

**Open-loop input impedance:** 10 ohms max., dc to 10 kHz; 50 60 pf max.) 1 M at dc; 150 k at 1 kHz.

**Open-loop output impedance:** 10 ohms max., dc to 10 kHz, 50 ohms max., 10 kHz to 1 MHz.

**Input noise:** (referred to summing point,  $<100 \text{ k}$  to ground)  $4 \mu\text{V}$  p-p max., 0 to 1 Hz;  $10 \mu\text{V rms}$  max., 0 to 1 kHz.

**Zero drift:** (referred to summing point,  $<100 \text{ k}$  to ground, 2-hr. warm-up) constant temperature,  $1 \mu\text{V}/\text{week}$  max.; temperature coefficient,  $0.5 \mu\text{V}/^\circ\text{C}$  max.

**Zero adjustment:** (referred to summing point)  $\pm 5 \mu\text{V}$ .

**DC output capability:** voltage,  $\pm 10 \text{ V}$ ; current,  $\pm 10 \text{ mA}$ , dc to 10 kHz (6 dB/octave decrease, 10 kHz to 1 MHz).

**Overload:** amplifier limiting,  $\pm 11$  to  $\pm 12.5 \text{ V}$  output; recovery, equal to rise time plus 20  $\mu\text{sec}$  (5 mA max. to sum point).

**Output load:** max. capacitive load for stability, 0.1  $\mu\text{F}$  for gain  $>10$ ; 0.01  $\mu\text{F}$  for gain  $<10$ ; short circuit does not damage instrument.

**Power:** 115 or 230 V  $\pm 10\%$ , 50 to 1000 Hz, 4 W approx.

**Dimensions:** 3" high, 5" wide, 17" deep (76 x 130 x 406 mm).

**Weight:** (includes a plug-in): net 6 lbs (2.7 kg); shipping 12 lbs (5.5 kg).

**Accessories available:** 5060-1938 Combining Case, holds 6 amplifiers, \$200; 5060-0792 Filler Panel, covers one panel opening in combining case, \$3 each; 5060-0828 Control Panel Cover, converts combining case to carrying case, \$23; 5060-0808 Adapter Frame, holds 3 amplifiers, \$25.

**Options:** overload indication, front-panel lamp and output signal, order 2460A-M1, \$480.

**Price:** 2460A (less plug-in), \$445.

### 2461A-M1 Data Systems Plug-in

**Gain (Inverting):** fixed settings, 10, 30, 100, 300, 1000 (X0 position shorts output); adjustment,  $\pm 2\%$  on each range (front-panel screwdriver control).

**Input resistance:** 100 k  $\pm 0.2\%$ , 50 pF nominal.

**Output resistance:** 50 milliohms maximum.

**Bandwidth and settling time:** (signal must be within output capability, see 2460A spec).

**DC gain accuracy:** see table; calibrated on X10 range, temp. range 10 to  $50^\circ\text{C}$ .

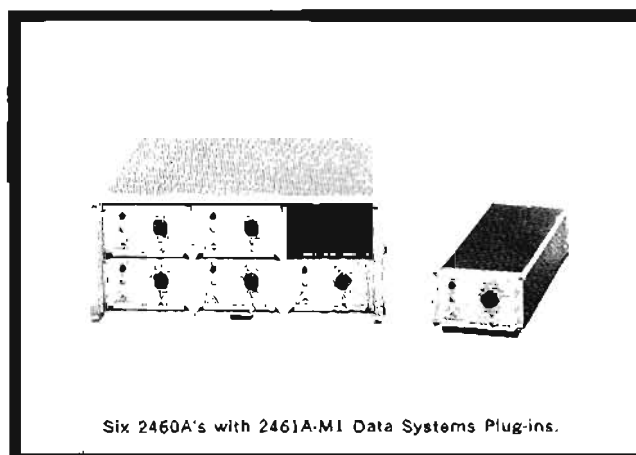

Gain	Min. 3 dB bandwidth	Max. settling time to 0.1 %	Accuracy
	25 kHz	50 $\mu\text{sec}$	—
	15 kHz	75 $\mu\text{sec}$	$\pm 0.5\%$
	5 kHz	250 $\mu\text{sec}$	$\pm 0.5\%$
X300	1.5 kHz	750 $\mu\text{sec}$	$\pm 1\%$
X1000	350 Hz	3.5 msec	$\pm 1\%$

**Price:** 2461A-M1, \$83; combined with amplifier, \$530.

### 2461A-M2 Bench-Use Plug-in

**Gain (Inverting):** fixed settings, 1, 10, 100, 1000 (X0 position shorts output); vernier, extends gain each setting, from X1 to X10.

**Input resistance:** 100 k  $\pm 0.2\%$ , 50 pF nominal

**Output resistance:** 50 milliohms max.

**Bandwidth and settling time:** see table below (signal must be within output capability; see 2460A specs).

**DC gain accuracy:** see table; vernier at 1; temp. range 10 to  $50^\circ\text{C}$ .

Gain	Min. 3 dB bandwidth	Max. settling time to 0.1 %	Accuracy
X1	50 kHz	25 $\mu\text{sec}$	$\pm 0.5\%$
X10	25 kHz	50 $\mu\text{sec}$	$\pm 0.5\%$
X100	5 kHz	250 $\mu\text{sec}$	$\pm 1\%$
X1000	350 Hz	3.5 msec	$\pm 1.5\%$

**Price:** 2461A-M2, \$125; combined with amplifier, \$570.

### 2461A-M3 Patch Unit Plug-in

Patch panel provides connections for up to 3 inputs and 1 feedback path. Inputs, output, circuit ground and chassis ground available at both front panel and rear connector; summing point available at front panel only; overload signal at rear only. Price: 2461A-M3, \$75; combined with amplifier, \$520.

### 2461A-M4 Plus-One Gain Plug-in

**Gain:** X1; non-inverting.

**DC gain accuracy:** (includes linearity, long term stability, 10 to  $50^\circ\text{C}$ )  $\pm 0.005\%$  into 1 k;  $\pm 0.0002\%$  into 100 k.

**Input resistance:**  $10^{10}$  ohms, for relative humidity up to 70% at  $40^\circ\text{C}$ .

**Output resistance:** 50 milliohms maximum.

**Price:** 2461A-M4, \$35; combined with amplifier, \$480.

# AMPLIFIERS



## AMPLIFIERS

Offer 20 or 40 dB gain

Models 450A, 466A

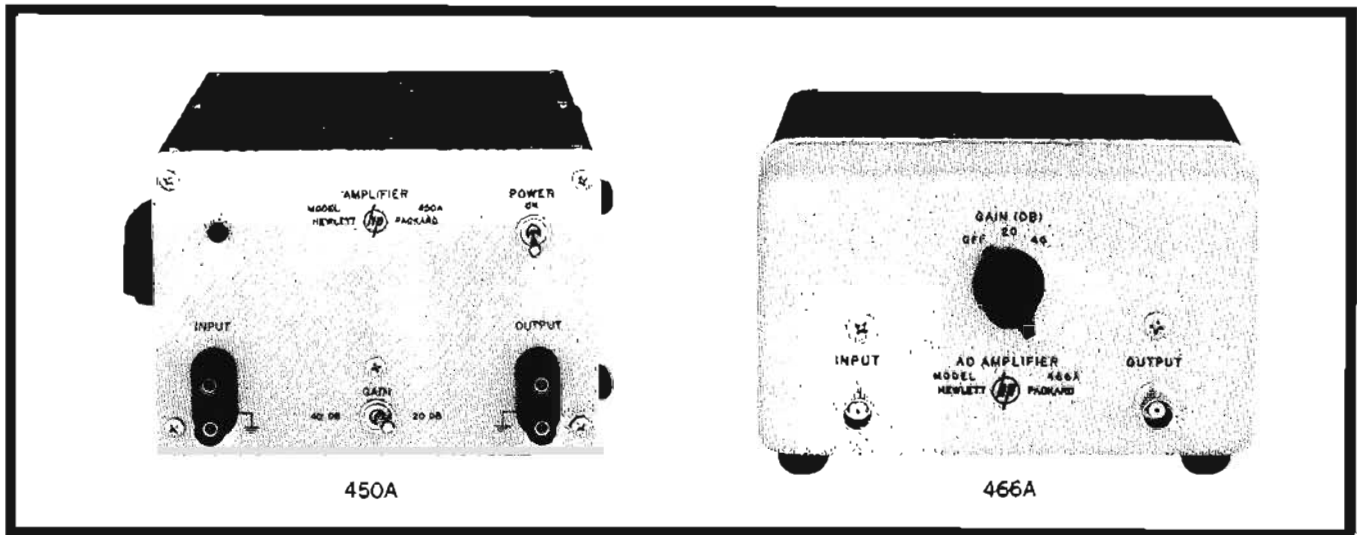

### 450A Stabilized Amplifier

The HP Model 450A is ideal as a general-purpose instrument wherever wide-frequency range and stable gain are essential. The instrument has an extremely stable 20 dB or 40 dB gain over a continuous frequency range of 10 Hz to 1 MHz. Either gain may be selected quickly with a toggle switch on the front panel.

The amplifier is resistance-coupled and does not use peaking or compensating networks. Optimum performance is obtained entirely from a straightforward amplifier design in combination with inverse feedback. Phase shift is negligible and there are no spurious oscillations or resonances.

#### Specifications, 450A

- Gain:** 20 dB (X10) or 40 dB (X100)  $\pm 0.125$  at 1000 Hz.
- Frequency response:** 40 dB gain:  $\pm 0.5$  dB, 10 Hz to 1 MHz;  $\pm 1$  dB, 5 Hz to 2 MHz; 20 dB gain:  $\pm 0.5$  dB, 5 Hz to 1 MHz;  $\pm 1$  dB, 2 Hz to 1.2 MHz.
- Stability:**  $\pm 2\%$ , includes line voltage variation 115 or 230 V  $\pm 10\%$ .
- Impedance:** input, 1 megohm, 15 pF shunt; internal, less than 150 ohms.
- Distortion:** less than 1%, 2 Hz to 100 kHz at maximum output; approximately 2% above 100 kHz.
- Output:** 10 V maximum into 3000-ohm or greater load.
- Noise referred to input:** 40 dB gain, 40  $\mu$ V; 20 dB gain, 250  $\mu$ V.
- Power:** 115 or 230 V  $\pm 10\%$ , 50 to 1000 Hz, 50 watts.
- Dimensions:** cabinet: 8 $\frac{3}{8}$ " wide, 5 $\frac{1}{2}$ " high, 10 $\frac{3}{4}$ " deep (219 x 140 x 273 mm); rack mount: 19" wide, 5 $\frac{1}{4}$ " high, 10 $\frac{3}{8}$ " deep behind panel (483 x 133 x 270 mm).
- Weight:** net 10 lbs (4.5 kg), shipping 15 lbs (6.8 kg) (cabinet); net 11 lbs (5 kg), shipping 23 lbs (10.4 kg) (rack mount).
- Price:** HP 450A, \$200 (cabinet); HP 450AR, \$205 (rack mount).

### 466A AC Amplifier

The HP Model 466A AC Amplifier is ideal wherever low distortion, stability, wide-frequency range, and portability are desirable; and it may be used to increase the sensitivity of voltmeters and oscilloscopes, since its gain is accurate and stable.

Model 466A is normally furnished with a plug-in supply for ac operation. For portable operation or for isolation from power lines, the supply may be quickly removed and replaced with batteries. If you wish, you may specify batteries in lieu of the plug-in supply (Option 01).

#### Specifications, 466A

- Gain:** 20 dB (X10) or 40 dB (X100)  $\pm 0.2$  dB at 1000 Hz.
- Frequency response:**  $\pm 0.5$  dB, 10 Hz to 1 MHz down 3 dB, or less at 5 Hz and 2 MHz.
- Output voltage:** 1.5 V rms across 1500 ohms.
- Output current:** 1 mA rms maximum.
- Noise:** 75  $\mu$ V referred to input, 100,000-ohm source.
- Impedance:** input, 1 megohm, 25 pF shunt; output, approximately 50 ohms in series with 100  $\mu$ F.
- Distortion:** less than 1%, 10 Hz to 100 kHz; less than 5% to 1 MHz.
- Power:** 115 or 230 V  $\pm 10\%$ , 50 to 1000 Hz, approximately 1 watt (supply normally furnished); battery operation optional: radio-type mercury batteries, TR234-316649 or equivalent, 3 required (HP #1420-0006); battery life approximately 150 hours.
- Dimensions:** 6 $\frac{1}{4}$ " wide, 4" high, 6 $\frac{1}{4}$ " deep (159 x 102 x 159 mm).
- Weight:** net 3 lbs (1.4 kg); shipping 4 lbs (1.8 kg).
- Price:** HP 466A, \$165, ac operation.
- HP 466A Option 01:** batteries in lieu of ac supply, \$150.

# SOLID-STATE AMPLIFIERS

Precision general-purpose amplifiers  
Models 465A, 467A



# AMPLIFIERS

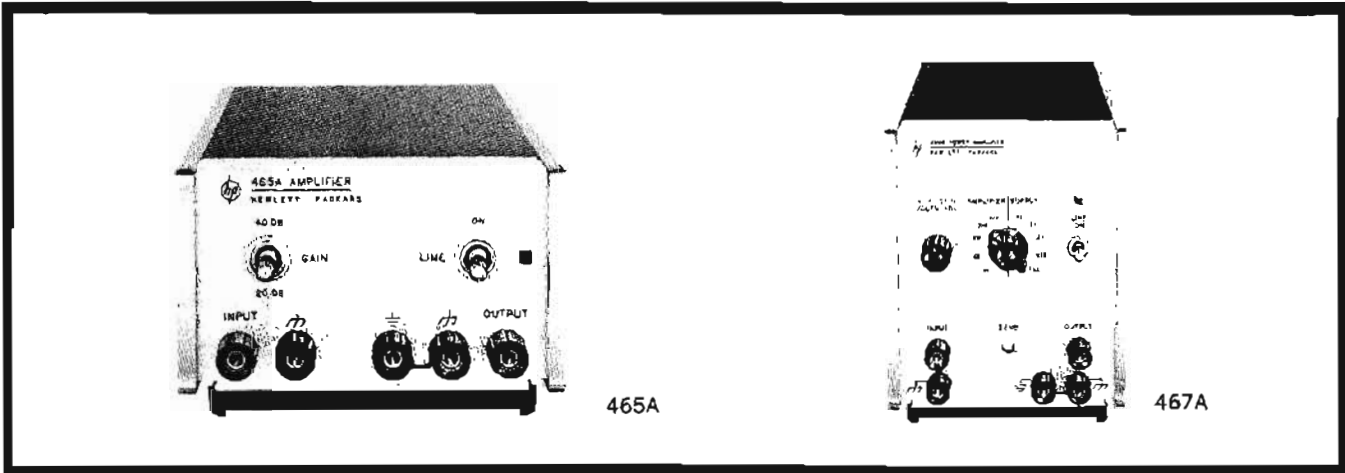

The HP Model 465A is a general-purpose amplifier and an excellent impedance converter (10 megohms to 50 ohms). This amplifier has extremely stable 20 dB or 40 dB gain over a continuous frequency range of 5 Hz to 1 MHz. Either gain may be selected rapidly with a switch on the front panel.

This solid-state amplifier is ideal for increasing the power output of solid-state oscillators or amplifiers. The output stage provides low-output impedance and wide dynamic range. The HP 465A is a three-terminal device isolated from chassis and may be floated up to 500 volts dc above chassis ground.

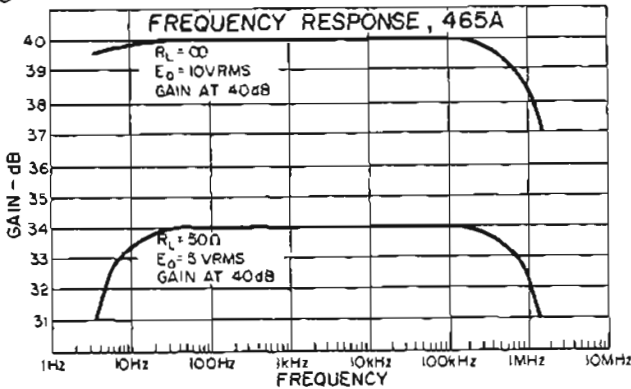

The solid-state HP 467A Power Amplifier/Supply is a 10-watt peak power amplifier and  $\pm 20$  volt dc power supply. The power amplifier has a wide bandwidth and low dc drift, suitable for many applications wherever a power source is required. Unique features are low distortion ( $< 0.01\%$ ), low drift and high-gain accuracy.

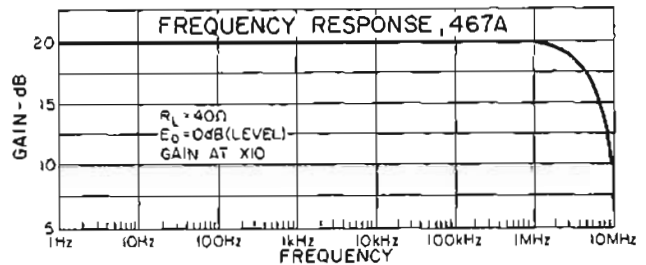

An output greater than  $\pm 20$  volts peak and 0.5 amp peak is available from dc up to 1 MHz. At full output the distortion of the 467A is less than 3% up to 1 MHz. The amplifier is a three-terminal device isolated from chassis and may be floated up to 200 volts dc above chassis ground. A front panel switch converts the amplifier to a power supply that delivers  $\pm 20$  volts dc at currents up to 0.5 amp.

	Specifications, 465A	Specifications, 467A
Voltage gain	20 dB (X10) or 40 dB (X100), open circuit	fixed steps: X1, X2, X5, X10; variable: 0 to 10, resolution better than 0.1% of full output
Gain accuracy	$\pm 0.1$ dB ( $\approx 1\%$ ) at 1000 Hz	$\approx 0.3\%$ , dc to 10 kHz with load of $> 40$ ohms
Frequency response	$\pm 0.1$ dB, 100 Hz to 50 kHz; $< 2$ dB down, 5 Hz to 1 MHz	$\approx 1\%$ , dc to 100 kHz, $\approx 10\%$ , dc to 1 MHz (fixed steps)
Output	$> 10$ V rms open circuit; $> 5$ V rms into 50 ohms ( $1/2$ watt)	$\pm 20$ V peak at 0.5 amp peak
Distortion	$< 0.1\%$ , 10 Hz to 100 kHz; $< 2\%$ , 5 Hz to 10 Hz and 100 kHz to 1 MHz	$< 0.01\%$ at 1 kHz; $< 1\%$ at 100 kHz; $< 3\%$ at 1 MHz
Input impedance	10 megohms shunted by less than 20 pF	50 k ohms shunted by 100 pF
Output impedance	50 ohms	5 milliohms in series with 1 $\mu$ H (front-panel connector only)
Noise	$< 25$ $\mu$ V rms referred to input (with 1 megohm source resistance)	5 mV rms peak-to-peak
DC power supply		voltage range: $> \pm 20$ V, $\approx 10$ V, $\approx 4$ V, $\approx 2$ V, $\approx 1$ V with continuously variable vernier between ranges; resolution: better than 0.1% output; current: $\approx 0.5$ amp; line and load regulation: $< 10$ mV change for $\approx 10\%$ line voltage change and 0 to 0.5 amp load change; current limit: $< 800$ mA; capacitor load: 0.01 $\mu$ F or less does not cause instability; ripple: $< 5$ mV p-p
Temperature range	0 to $+50^\circ$ C	0 to $+50^\circ$ C temperature coefficient: $< \pm 0.05\%/^\circ$ C or 2 mV/ $^\circ$ C, whichever is greater
Power	115 or 230 V, $\approx 10\%$ , 50 to 1000 Hz, 10 W at full load	115 or 230 V, $\approx 10\%$ , 50 to 1000 Hz, 35 W at full load
Dimensions	5 1/2" wide, 3-7/16" high, 1 1/2" deep (130 x 87 x 279 mm) (1/3 module)	5 1/2" wide, 5 1/2" high, 1 1/2" deep (130 x 165 x 279 mm) (1/3 module)
Weight	net 4 lbs (1.8 kg); shipping 6 lbs (2.7 kg)	net 10 lbs (4.5 kg); shipping 14 lbs (7.2 kg)
Price	\$190.	\$375





## WIDEBAND AMPLIFIERS

Wideband, fast-pulse amplifiers

Models 460AR, BR

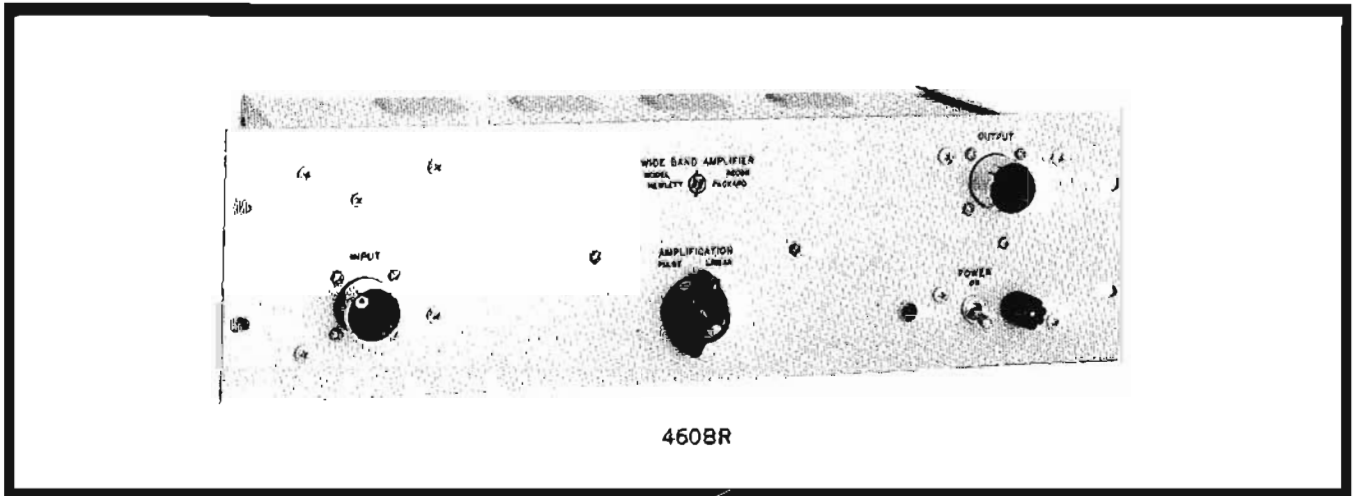

The HP 460 Amplifiers make it possible for you to obtain at moderate cost true amplification of fast pulses at power levels sufficient to operate scalars, counting meters and cathode-ray tubes.

The 460AR Wideband Amplifier is used fundamentally to provide voltage gain (approx. 20 dB). Its companion equipment, HP 460BR, is designed as a terminal amplifier to give maximum voltage or power output. The amplifier's short rise time of 3 ns, combined with zero overshoot, insures distortion-free amplification of pulses faster than 10 ns. The 460BR cascaded with the 460AR provides linear amplification of 16 volts peak output and, with two 460BR's, pulse amplification to 110 volts open circuit.

This unusual combination gives maximum usefulness for fast-pulse nuclear radiation problems, television, vhf, uhf or shf work. It also means the bandwidth of your standard oscilloscope can be increased to over 100 MHz and voltmeter sensitivity multiplied by 10. In cascade or singly, the amplifiers offer further convenience as general-duty, wide-band instruments for all types of laboratory problems.

### Specifications, 460AR

**Frequency response:** high frequency: closely matches Gaussian curve when operating into a 200-ohm resistance load, 3 dB point is 120 MHz; low frequency: off approx. 3 dB at 20 kHz when driven by a 200-ohm generator and operated into a 200-ohm load; off approx. 3 dB at 100 kHz when driven by a 0 source impedance and operated into a 200-ohm load; off approx. 3 dB at 3 kHz when operating into an open circuit (i.e., crt plates); with 410B and 11011A,  $\pm 1$  dB, 200 kHz to 200 MHz.

**Gain:** nominally 20 dB into 200-ohm load; control range, 6 dB.

**Sinusoidal output:** approx. 8 V peak open circuit; approx. 5 V peak into a 200-ohm load (<5% distortion when terminated into 200 ohms).

**Maximum pulse output:** +8 V (+ input), -20 V (- input) unloaded; +3.2 V (+ input), -8 V (- input) loaded.

**Impedance:** 200 ohms input, 300 ohms output.

**Noise figure:** less than 10 dB.

**Delay characteristics:** approximately 14 ns.

**Rise time:** nominally 3 ns (10% to 90%); no appreciable overshoot.

**Power:** 115 or 230 volts  $\pm 10\%$ , 50 to 1000 Hz, 50 watts.

**Dimensions:** 19" wide, 5-7/32" high, 7" deep (483 x 133 x 178 mm).

**Weight:** net 12 lbs (5, 4 kg); shipping 18 lbs (8 kg).

**Price:** HP 460AR, \$275.

### Accessories available

11006A Patch Cord, 200 ohms, 2' long, \$27.50.

11007A Patch Cord, 200 ohms, 6' long, \$31.50.

11008A Panel Jack for 200-ohm cables, low capacitance, \$10.

11009A Cable Plug for 200-ohm systems, \$9.00.

11010A 50-ohm Adapter, Type N to HP 460, 50-ohm termination, \$17.50.

11011A Adapter, bayonet sleeve for connecting HP 410B vtvm to output of 460A amplifiers, \$40.

11012A Connector Sleeve joins two 11009A Cable Plugs, \$10.00.

11013A Adapter for connecting to 5 XP crt, \$11.50.

11015A Adapter, Type N to HP 460, 200-ohm termination, \$17.50.

11016A Adapter, Type N to HP 460, no termination, \$20.00.

11017A Adapter, HP 410B vtvm to HP 460, 200-ohm termination, \$35.

8120-0014 Cable, 200 ohms, specify length; per foot, \$1.50.

### Specifications, 460BR

(Same as 460AR except as follows)

**Gain:** nominally 15 dB into 200-ohm load.

**Sinusoidal output:** approx. 8 V peak, 200-ohm load; 16 V peak, open circuit.

**Maximum pulse output:** +16 V (- input), -110 V (+ input) unloaded; +8 V (- input), -60 V (+ input) loaded; (+8 V input required for -100 V output); linear: +16 V (- input), -16 V (+ input) unloaded; +8 V (- input), -8 V (+ input) loaded.

**Duty cycle:** 5%.

**Impedance:** 200 ohms, input and output.

**Delay characteristics:** approximately 16 ns.

**Noise figure:** less than 6 dB.

**Price:** HP 460BR, \$325.

## SOLID STATE AMPLIFIERS

Wide band, 40 dB solid-state amplifiers

Models 461A, 462A



## AMPLIFIERS

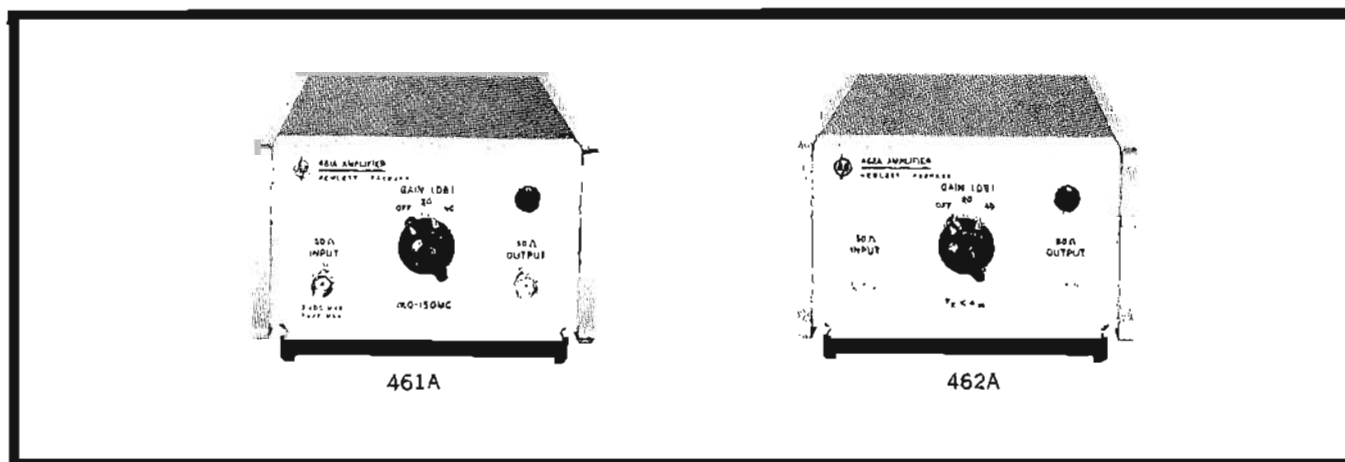

The solid-state HP 461A and 462A Amplifiers are excellent wherever wide-frequency range, low distortion and portability are desired.

The 461A Amplifier is a general-purpose instrument designed to deliver stable gain over a wide-frequency range. Either 20 dB or 40 dB gain may be selected with a front-panel switch. Figure 1 illustrates the typical frequency response of the 461A. Both input and output impedances are matched to 50 ohms. Maximum output is  $\frac{1}{2}$  volt rms.

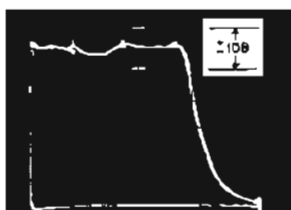

Figure 1. Frequency response curve of HP 461A. Markers shown from left to right are: 50, 100, 150 and 200 MHz. Gain control is set in 20 or 40 dB position.

The ability of the 462A to amplify very fast pulses can be seen in Figure 2. The upper trace (A) shows a 20 ns pulse applied to the input of the 462A Amplifier. The lower trace shows the same pulse amplified at 40 dB, as viewed on the HP 185B Sampling Oscilloscope.



Figure 2. (A) Input Pulse to HP 462A (5 mV peak to peak). (B) Output Pulse of HP 462A (500 mV peak to peak). Gain control is set in 40 dB position. Sweep speed is 5 ns/cm.

This amplifier gives maximum usefulness for fast-pulse applications, television, and vhf work.

### Specifications, 461A

- Frequency range:** 1 kHz to 150 MHz.
- Frequency response:**  $\pm 1$  dB, 1 kHz to 150 MHz, when operating into a 50-ohm resistive load (500 kHz reference).
- Gain at 500 kHz:** 40 dB  $\pm 0.5$  dB; or 20 dB  $\pm 1.0$  dB, selected by front-panel switch (inverting).
- Input impedance:** nominal 50 ohms.
- Maximum input:** 1 volt rms or 2 volts p-p pulse.
- Maximum dc input:**  $\pm 2$  volts.
- Output:** 0.5 volt rms into 50-ohm resistive load.
- Equivalent wideband input noise level:** less than 40  $\mu$ V in 40 dB position.
- Distortion:**  $< 5\%$  at maximum output and rated load.
- Overload recovery:**  $< 1$   $\mu$ s for 10 times overload.

### Specifications, 462A

- Pulse response:** leading edge and trailing edge: rise time, less than 4 nanoseconds; overshoot, less than 5%.
- Pulse overload recovery:** less than 1  $\mu$ s for 10 times overload.
- Pulse duration for 10% droop:** 50  $\mu$ s.
- Equivalent input noise level:** less than 40  $\mu$ V in 40 dB position.
- Input impedance:** nominal 50 ohms.
- Maximum input:** 1 volt rms or 2 volts p-p pulse.
- Maximum dc input:**  $\pm 2$  volts.
- Gain:** 20 or 40 dB selected by front-panel switch (inverting).
- Output:** 1 volt peak-to-peak into 50-ohm resistive load.
- Delay:** nominally 12 to 14 nanoseconds.

### General Specifications

- Dimensions:** 3 $\frac{1}{8}$ " high, 5 $\frac{1}{8}$ " wide, 11" deep (87 x 130 x 279 mm).
- Weight:** net 4 lbs (1.8 kg); shipping 6 lbs (2.7 kg).
- Power:** 115 or 230 volts  $\pm 10\%$ , 50 to 1000 Hz, 5 watts.
- Connectors:** BNC female.
- Accessories available:** 11058A 50- to 200-Ohm Transformer, \$50; 11048B 50-Ohm Feed-thru Termination, \$10; Combining Cases: 1051A, \$110, or 1052A \$120, (each holds six 461A, 462A Amplifiers).
- Price:** HP 461A, \$325; HP 462A, \$325.



## PRECISION AMPLIFIER

Low level measurements; precision application  
Model 463A

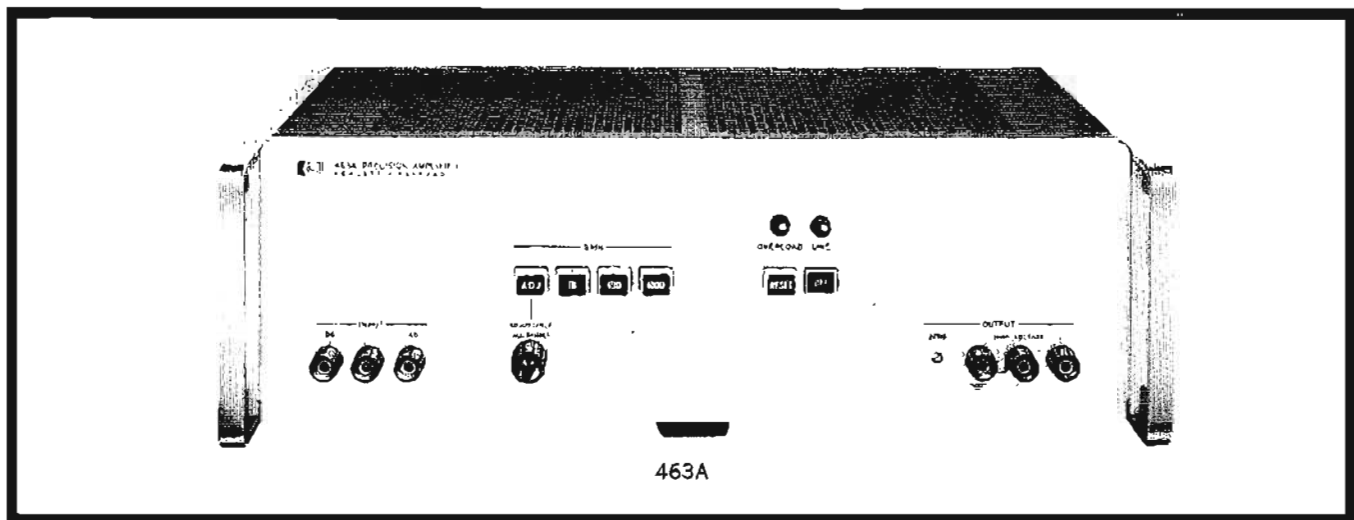

A precision amplifier, the solid-state HP 463A has gain accuracy better than  $\pm 0.001$  dB (0.01%) with long-term stability of 100 ppm/year, distortion below 0.01% and output capability up to 100 volts rms at 5 watts continuous. The 463A has a bandwidth from dc to 1 MHz and low dc drift offering use in many applications such as obtaining a high-voltage, low-frequency generator when used with the HP 3300A; a low-distortion, high-voltage source when used with the HP 203A; for low-level ac measurements when used with the 3440A DVM and 3445A Plug-in or 741B  $\Delta$ VM. The 100 volt output capability makes it practical to measure as much as 110 dB of attenuation. It is ideal to amplify the output of most solid-state oscillators, or to use as an isolator for thermocouple transfer measurements. The 100 volt output, with current up to 50 mA, is sufficient to drive magnetic memory cores. The HP Model 463A Precision Amplifier was designed to meet the most critical requirements for high-accuracy, wide dynamic-range and low-distortion applications.

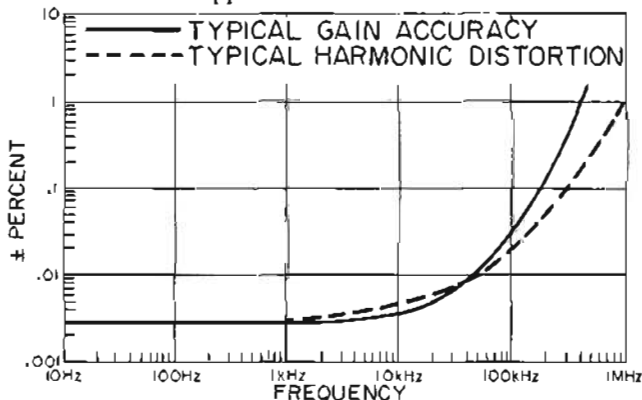

\*Specifications, 463A

## Input:

Fixed gain impedance (Z): 1 megohm  $< 35$  pF.  
Adjustable gain Z: 50 k ohm  $< 200$  pF.  
Coupling: ac or dc.

\*For complete data refer to Technical Data Sheet.

Zero drift:  $\pm 200$   $\mu$ V/ $^{\circ}$ C dc coupled.

$\pm 2$  mV/ $^{\circ}$ C ac coupled.

Noise (rms): X10 range: 1.5 mV.

X100 range: 150  $\mu$ V.

X1000 range: 50  $\mu$ V.

## Gain:

Fixed: X10, X100, X1000.

Adjustable: 0–100% all ranges.

Accuracy: 0.01% on X10 range; 0.1% on X100 range; 0.3% on X1000 range.

## Frequency Response:

DC coupled:

X10 gain: dc to 10 kHz,  $< \pm 0.001$  dB; 10 kHz to 100 kHz,  $< \pm 0.01$  dB; 100 kHz to 1 MHz,  $< \pm 3$  dB.

X100 gain: dc to 10 kHz,  $< \pm 0.01$  dB; 10 kHz to 100 kHz,  $< \pm 0.1$  dB.

X1000 gain: dc to 10 Hz,  $< \pm 0.1$  dB; 10 Hz to 20 kHz,  $< \pm 0.03$  dB; 20 kHz to 100 kHz,  $< \pm 0.3$  dB.

(Ac-coupled is same as above except  $-3$  dB at 0.5 Hz at fixed gain.)

## Output:

Voltage: dc: 110 V, 20 mA; ac: 100 V rms, 50 mA.

Power: 5 watts.

Impedance: X10 range; 0.05 ohms dc to 10 kHz, 0.5 ohms 10 kHz to 100 kHz.

X100 range: 0.2 ohms dc to 10 kHz, 2 ohms 10 kHz to 100 kHz.

X1000 range: 2 ohms dc to 10 kHz, 20 ohms 10 kHz to 100 kHz.

Distortion:

X10 gain:  $< 10$  kHz,  $< \pm 0.01\%$ ;  $< 100$  kHz,  $< 0.1\%$ .

X100 gain:  $< 10$  kHz,  $< \pm 0.03\%$ ;  $< 100$  kHz,  $< 0.1\%$ .

X1000 gain:  $< 10$  kHz,  $< \pm 0.1\%$ ;  $< 100$  kHz,  $< 0.5\%$ .

## General:

Temperature range: 0 to  $+50^{\circ}$ C.

Power: 115 or 230 V,  $\pm 10\%$ , 50 to 1 kHz, approx. 50 watts full load.

Dimensions:  $5\frac{7}{8}$ " high,  $16\frac{3}{4}$ " wide,  $13\frac{1}{4}$ " deep (132,6 x 425,6 x 336,6 mm).

Weight: net 19 lbs (8,6 kg); shipping 23 lbs (10,3 kg).

Price: HP 463A, \$590.

## POWER AMPLIFIER

Provides more than 4.5 watts, 10 to 500 MHz  
Model 230A



## AMPLIFIERS

The HP 230A Signal Generator Power Amplifier is the ideal solution to high rf power requirements, including receiver testing, wattmeter calibration, antenna testing, filter and component testing and attenuation measurements.

The amplifier may be conveniently driven with any conventional signal generator and is designed to reproduce

AM, FM and pulse modulation characteristics of the driving generator with minimum distortion.

The 230A employs three tuned, cascaded stages of grounded-grid amplification fed from a regulated power supply. An rf output voltmeter is also included and the unit is designed for either standard 19" rack or cabinet use.

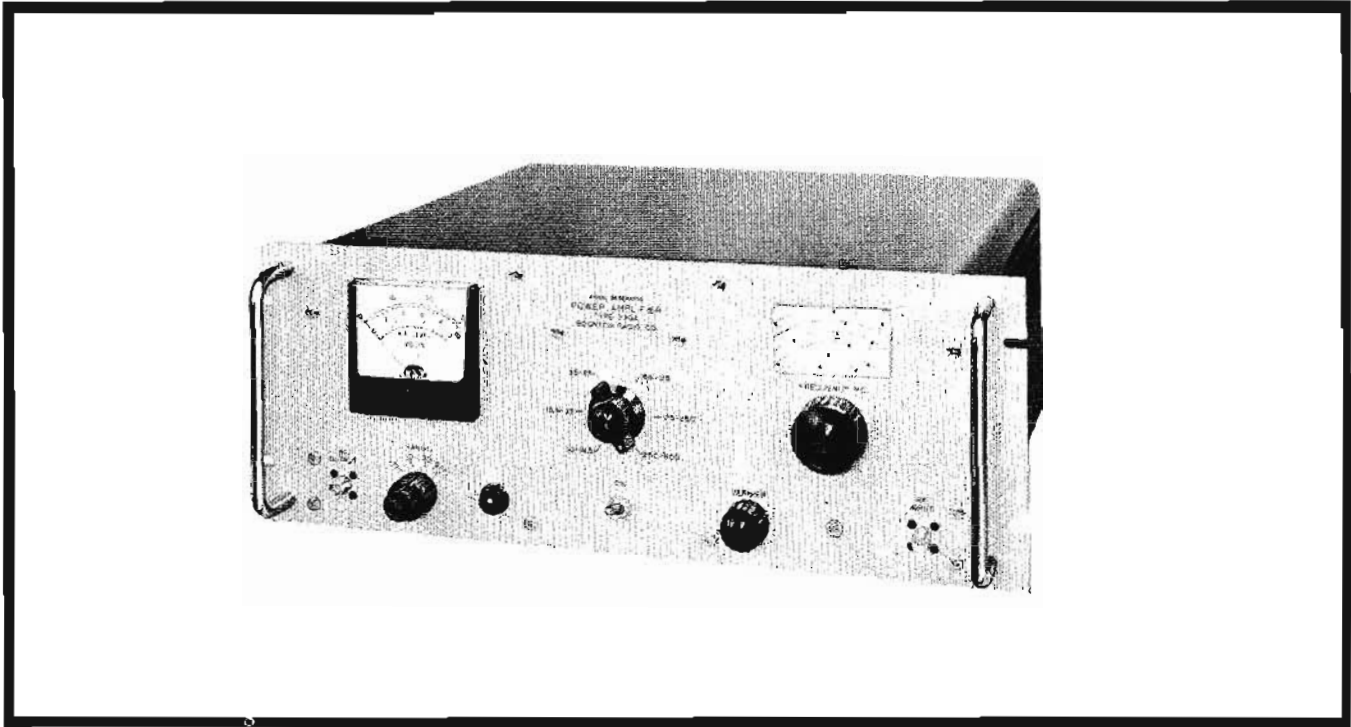

### Specifications

#### Radio frequency characteristics

**RF range:** total range: 10 to 500 MHz; number bands: 6; band ranges: 10 to 18.5 MHz, 18.5 to 35 MHz, 35 to 65 MHz, 65 to 125 MHz, 125 to 250 MHz, 250 to 500 MHz.

**RF calibration:** increments of approximately 10%, accurate to  $\pm 10\%$ .

**RF output:** range: up to 15 volts (across external 50-ohm load); calibration: 0.2 to 3 volts f.s., increments of approx. 5%; 1 to 10 volts f.s., increments of approx. 5%; 2 to 30 volts f.s., increments of approx. 5%; accuracy:  $\pm 1$  dB of f.s. (10 to 250 MHz),  $\pm 1.5$  dB of f.s. (250 to 500 MHz); impedance: 50 ohms; leakage: effective shielding is greater than 40 dB.

**RF bandwidth:**\*  $> 700$  kHz (10 to 150 MHz);  $> 1.4$  MHz (150 to 500 MHz).

**RF input:** level\*\*:  
 $\leq 0.316$  volts, 30 dB gain, (10 to 125 MHz);  
 $\leq 0.446$  volts, 27 dB gain, (125 to 250 MHz);  
 $\leq 0.63$  volts, 24 dB gain, (250 to 500 MHz).

\*Frequency interval between points 3 dB down from max. response.

\*\*For 10 volts output into 50 ohms.

#### Amplitude modulation characteristics

**AM range:** reproduces modulation of driving signal generator 0 to 100%†.

**AM distortion:**  $< 10\%$  added to distortion of driving signal generator†.

#### Frequency modulation characteristics

**FM range:** reproduces modulation of driving signal generator except as limited by the rf bandwidth.

**Incidental AM:** 10% added to modulation of driving signal generator (at 150 kHz deviation).

**FM distortion:** negligible distortion added to distortion of driving signal generator for deviations and modulation frequencies  $< 150$  kHz.

#### Physical characteristics

**Dimensions:** 16 $\frac{3}{4}$ " wide, 7-3/16" high, 18-1/16" deep (425 x 183 x 459 mm).

**Weight:** net 37 lbs (16,7 kg); shipping 45 lbs (20,3 kg).

**Power:** 105 to 125 or 210 to 250 V, 50 to 60 Hz, 150 W.

**Price:** HP 230A, \$1200.

†Up to 5 volt max. carrier output for up to 100% AM.

# AMPLIFIERS



## MICROWAVE AMPLIFIERS

Broadband, high-gain, high-power amplification  
Models 489A, 495A

### Advantages:

- DC-coupled modulation circuitry allows power leveling and remote programming
- PPM focusing means fewer alignment problems

### Uses:

- Antenna efficiency and pattern measurements
- Extends attenuation measuring systems capability by at least 30 dB

Amplification of frequencies from 1 to 12.4 GHz is accomplished in four ranges by the Hewlett-Packard microwave amplifiers. Each delivers at least 1 watt with an input of 1 mW or less, a gain of at least 30 dB.

Amplitude modulation circuitry has been designed for wide bandwidth (down to dc) and with internal amplification, so that small modulation signals cause a large output power change. This unique modulation circuitry also permits power leveling with external elements, plus remote

programming. Spurious phase modulation of  $0.1^\circ$  or less and residual AM at least 45 dB below carrier are assured by regulation of the filament, anode and helix power supplies. TWT cathode current is monitored by a front-panel meter and can be controlled by the Gain adjustment for rated power output, or for reducing tube current to extend tube life when full output power is not required. Helix, collector and anode current can be measured at an easily accessible test point board.

Periodic permanent magnet focusing reduces weight, size and power consumption and at the same time alleviates alignment problems. Protective features incorporated to prevent TWT failure include an overload relay on the helix power supply, a three-minute time delay on the beam supply and a fail-safe circuit that disconnects ac power whenever the regulated filament supply voltage exceeds a predetermined level.

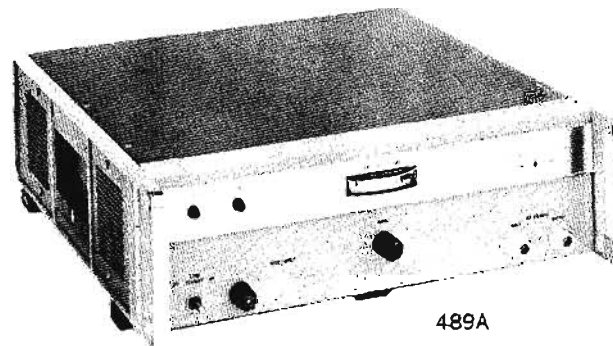

489A

### Specifications

	489A	491C	483A	496A
Frequency range (GHz)	1-2	2-4	4-8	7-12.4
Power output (with 1 mW or less input)	1 W	1 W	1 W	1 W
Gain at rated output	30 dB	30 dB	30 dB	30 dB
Gain variation with freq. at rated output small signal across any 10% of band across full band	≤6 dB	≤6 dB	≤6 dB	≤6 dB
	≤5 dB	≤5 dB	≤5 dB	≤5 dB
	≤10 dB	≤10 dB	≤12 dB	≤10 dB
Gain variation with =10% variation from rated line voltage	≤1 dB	≤1 dB	≤1 dB	≤1 dB
Noise max. noise figure typ. noise power out	30 dB	30 dB	30 dB	30 dB
	-10 dBm	-10 dBm	0 dBm	0 dBm
Price	\$2250	\$2250	\$2600	\$2600

### For all models

Maximum rf input: 100 mW.

Input/output characteristics: impedance, 50Ω; reflection coefficient (cold), ≤0.43 (2.5 swr, 7.3 dB return loss); connectors, type N female.

### Amplitude modulation

Sensitivity: a signal -20 volts peak at the modulation input reduces rf output by more than 20 dB.

Frequency response: dc to 500 kHz (3 dB).

Input impedance: 100 kΩ shunted by approx. 50 pF.

Pulse response: <1 μsec rise and fall times.

Residual AM: at least 45 dB below carrier.

Dimensions: 16 $\frac{3}{4}$ " wide, 5 $\frac{1}{2}$ " high, 18 $\frac{3}{8}$ " deep (426 x 141 x 467 mm); hardware furnished for conversion to rack mount 19" wide, 5-7/32" high, 16 $\frac{3}{8}$ " deep behind panel (483 x 133 x 416 mm).

Weight: net 38 lbs (17.1 kg); shipping 43 lbs (19.4 kg).

Power: 115 or 230 volts ±10%, 50 to 60 Hz, approx. 225 watts.

Accessories available: 11500A Cable Assembly, \$15; 11501A Cable Assembly, \$15.

## GENERAL INFORMATION



## OSCILLOSCOPES

The cathode-ray oscilloscope is an extremely fast x-y plotter which plots an input signal versus another signal or versus time. The "stylus" is a luminous spot which moves over the display area in response to input voltages. In the usual scope application, the x-axis input is an internally generated linear ramp voltage which moves the spot uniformly from left to right across the display screen. The voltage being examined is applied to the y-axis input, moving the spot up or down in accordance with its instantaneous value. The spot then traces a curve which shows how the input voltage varies as a function of time.

When the signal being observed is repetitive at a fast enough rate, the display appears as a steady line. The cathode-ray oscilloscope, thus, is a means of visualizing time-varying voltages. As such, it has become a universal tool in all kinds of electronic investigations. In addition to voltages, a scope can present visual representations of a wide variety of dynamic phenomena by the use of transducers for converting current, strain, acceleration, pressure and other physical quantities into voltages.

### The cathode-ray tube

The cathode-ray tube (crt) is the heart of the cathode-ray oscilloscope, with the rest of the instrument consisting of circuitry for operating the crt. As is commonly known, this tube has an electron gun at one end and a phosphor display screen at the other end. The gun has a thermionic cathode, various accelerating electrodes for directing emitted electrons toward the display screen, and a focusing electrode. The resulting narrow beam of electrons from the gun strikes the phosphor in a small spot with enough energy to cause fluorescence.

On leaving the gun, the electron stream passes between each of two pairs of deflection electrodes. Voltages applied to these electrodes bend the beam, voltages on one pair of electrodes moving the beam up and down and voltages on the other pair moving it from side to side. These movements are independent of each other, so that the spot

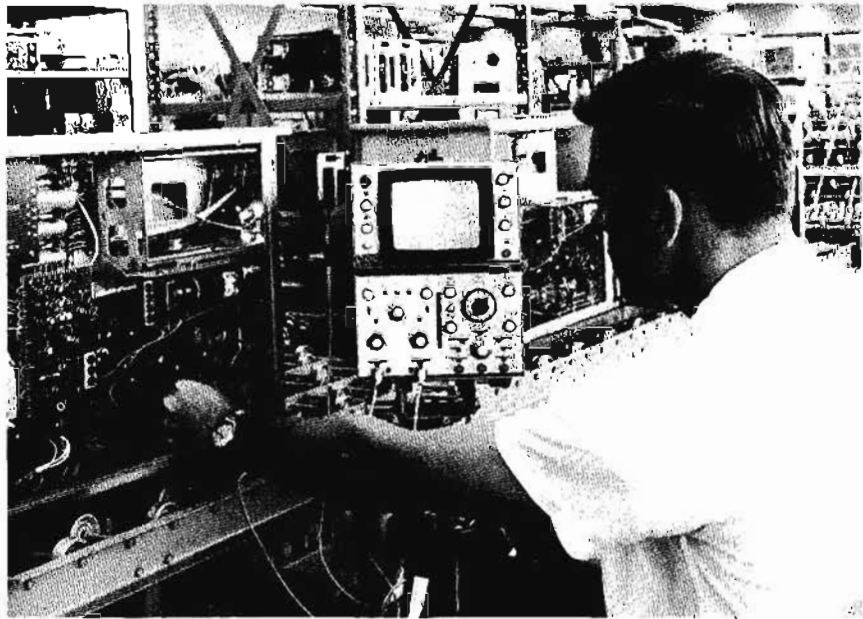

may be positioned anywhere on the phosphor screen by appropriate voltage inputs.

The accuracy with which the viewed waveform corresponds to the deflection voltages depends in large measure on the performance of the cathode-ray tube. Careful design of the electrodes and the precision manufacturing techniques of the Hewlett-Packard cathode-ray tube facility insure that the beam moves linearly with respect to the deflection voltages. Precision CRT's make it possible to measure accurately the input voltage amplitude at any point on the waveform by measurement of the amount of deflection of the fluorescent spot.

The cathode-ray tubes in most low-frequency scopes are mono-accelerator types in which all electron acceleration takes place in the gun section. The electron stream is not subjected to any electrostatic fields after leaving the gun section, insuring straight-line travel to the phosphor screen. Accurate deflection factors result and the bright, clear cathode-ray trace remains sharply focused throughout the large display area.

The Model 132A Dual-Beam Oscilloscope uses a dual electron gun crt together with two pairs of horizontal and vertical deflection plates and amplifiers to achieve two completely independent displays. This allows

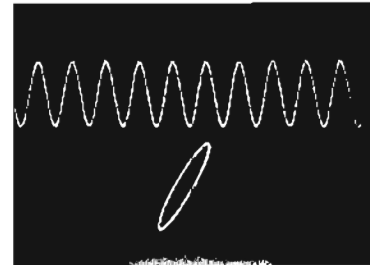
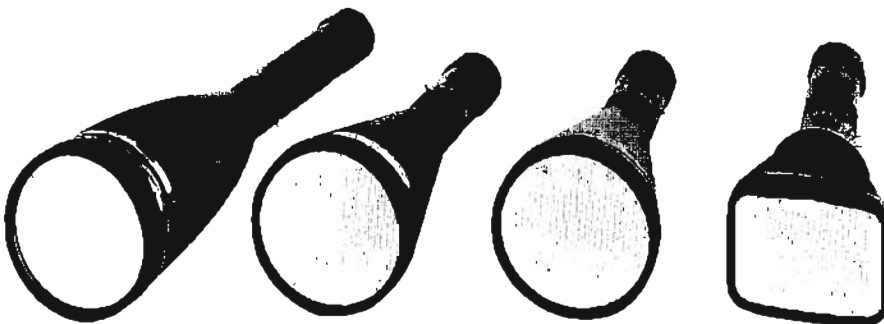

Figure 1. Two completely independent beams allow the Model 132A to make a wide variety of measurements.

dual x-y measurements, simultaneous x-y and y-t plots, and displays with two different sweep speeds. The dual-beam scope is also ideal for transit study of rapidly changing signals, since a single-beam dual-trace scope cannot display two single shots at high sweep speeds.

High-frequency oscilloscopes require a cathode-ray tube (CRT) which produces bright traces even at fastest sweeps with low duty cycle signals. An additional accelerating potential, known as a post-acceleration voltage, is applied between the gun and phosphor screen regions to obtain the bright traces.

New designs in CRT's have increased the size of the display window and reduced the overall length of the tube. In the Model 180A Oscilloscope the rectangular bottle allows an





eight centimeter horizontal deflection. Magnification is obtained, while retaining 3 V/cm vertical drive sensitivity, by using a curved, high-transmission mesh at the exit side of the deflection region. The overall acceleration

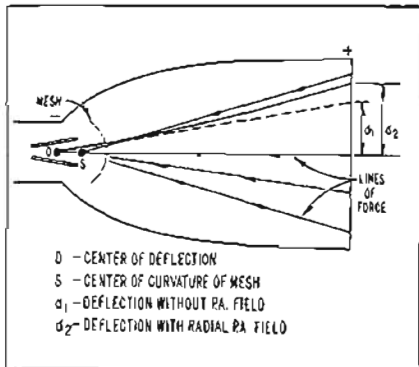

Figure 2. The HP-developed mesh crt makes possible the high performance of the Model 140A and 180A scopes.

potential is 12 kV for brightness. In the Model 140A Oscilloscope this mesh permits a 10 x 10 cm display area with 7.5 kV of accelerating potential.

### Internal graticule

A graticule, usually rectangular, is placed in the display area to allow accurate measurements of the display. All HP CRT's incorporate an internal graticule which is placed in the same plane as the phosphor. The internal graticule avoids errors caused by parallax which otherwise exists when the graticule is external to the tube, separated from the phosphor by the thickness of the glass face-plate.

### Basic oscilloscope circuitry

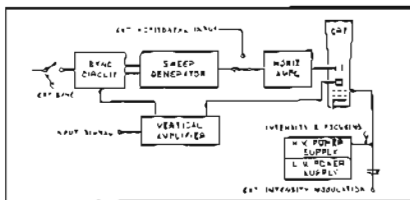

Figure 3. Oscilloscope block diagram.

The primary subsystems of a cathode-ray oscilloscope are the crt, the vertical deflection system, the horizontal deflection system, and the power supplies. The power supplies include focusing and intensity controls for adjusting the crt spot.

The horizontal deflection system supplies drive voltages for moving the electron beam horizontally. Since so many measurements

are concerned with plotting voltage versus time, the horizontal deflection system also includes sawtooth waveform generators for sweeping the beam horizontally at a uniform rate, plus synchronizing circuits for starting the horizontal sweep at a specific instant with respect to the measured waveform.

The horizontal amplifiers of all Hewlett-Packard scopes may be used separately from the sweep generating circuits for deflecting the horizontal beam in response to external waveforms, a useful technique for making x-y plots.

The vertical deflection system consists of an amplifier chain for amplifying low-level input signals sufficiently to drive the crt spot. Attenuators are included, so that a wide range of input signal amplitudes may be accommodated within the vertical dimension of the display area.

### Vertical amplifiers

The amplifiers in Hewlett-Packard oscilloscopes are stable enough to permit voltage measurements with confidence to at least  $\pm 3\%$  accuracy. To verify amplifier accuracy, all scopes have built-in calibrators which supply precisely controlled signals for use as calibrating test signals.

High amplifier gain, with minimum drift and noise, is obtained in HP scopes by careful circuit design. Large amounts of negative feedback, aided by the use of regulated power supplies, achieve gain stability for measurement accuracy.

DC coupling, included on all scopes, preserves the waveform of slowly varying signals and also permits a dc reference line to be established on the display, facilitating precise amplitude measurements. DC coupling is not desirable, though, when a small ac component on a relatively large dc voltage is to be examined. All HP scopes have provision for inserting decoupling capacitors into the signal line when dc coupling is not desired.

Excellent dc stability with virtually no drift is achieved through the use of a DC Stabilizer (as used in the Model 155A Oscilloscope and Model 1406A and 1407A Plug-ins) recently developed by HP. The stabilizer corrects (approximately 3 times per second) for any drift by means of a sampling feedback circuit. The correction is made at the end of a sweep, and therefore, is unnoticed by the operator.

Another recent advancement is the use of field effect transistors as used in the Model 180A Oscilloscope. The Model 180A amplifier circuits were designed to use FET's instead of vacuum tubes or nuvistors. This development permitted the design of a 100% solid state oscilloscope (except for the crt). Field effect transistors also considerably reduce amplifier drift, and virtually eliminate turn-on drift. This allows accurate measurement as soon as the crt warms up.

Differential input, for accepting balanced

signals, is available in many HP scopes. The balanced amplifier design means that balanced input signals can be connected directly to these scopes. When used in the differential mode, the scope displays the voltage difference between the signals on the two input leads, while canceling "in-phase" (common mode) voltages existing on both leads. The Model 1403A Plug-in, for example, has a common mode rejection ratio as high as 106 dB; which allows maximum sensitivity to be used with low level signals such as transducer outputs.

Delay lines in the vertical amplifiers of the 175A, 180A, and 1402A 20 MHz Plug-in for the Model 140A/141A oscilloscopes allow observation of the leading edge of the waveform which triggers the sweep. Sync takeoff occurs ahead of the delay line, allowing the sweep circuit sufficient time to get under way before the leading edge is actually displayed. The strip-line delay line used in the Model 180A is another new feature recently developed by HP. It is small, lightweight, and provides a delay of 160 nsec with a bandwidth of 140 MHz.

A widely used option in scope vertical deflection systems is the provision for two signal channels. Dual-channel operation is obtained most conveniently by electronic switching between signal channels, resulting in alternate displays of the two signals. Switching may occur between sweeps so that the waveform of one channel is displayed during one sweep, and the other waveform is displayed on the next sweep; or switching may occur rapidly (40 kHz to 1 MHz) for displaying samples of both channels during one sweep. This latter method, frequently referred to as "chopped" presentation, is most often used for low-frequency waveforms which otherwise would flicker with alternate-sweep presentation.

Dual-channel presentation enables comparison studies of two signals, such as phase measurements or studies of an amplifier's output signal versus its input. The two inputs of dual-channel scopes have separate pre-amplifiers and attenuators for independent adjustment of the amplitudes of the two signals.

The crt of the Model 132A has two electron guns and two sets of deflection plates. This arrangement allows single-shot observations of events that are too fast for the "chopped" dual-trace method described above. Also, simultaneous x-y and y-t displays or two different sweep speeds are possible without expensive delay generators usually found only in elaborate high-frequency scopes.

### Horizontal amplifiers

The amplifiers for horizontal deflection in HP low-frequency scopes have phase shift characteristics which are matched to the vertical amplifiers up to and beyond 100 kHz. In particular, the Model 130C features vertical and horizontal amplifiers which have



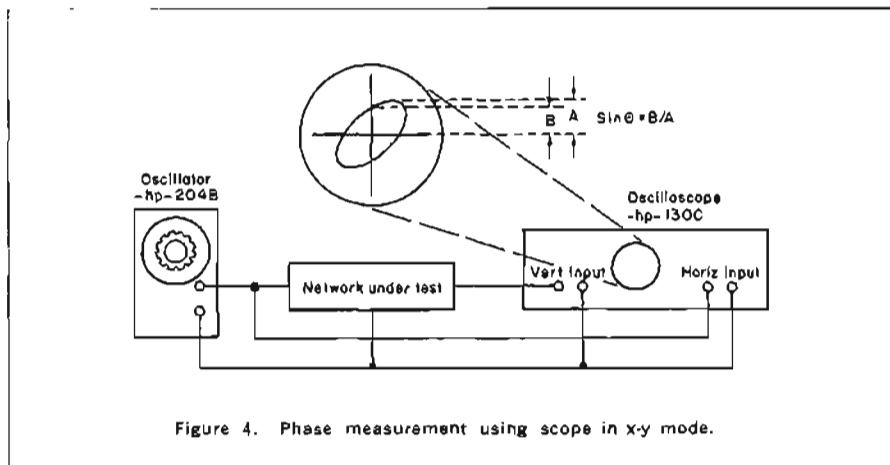

Figure 4. Phase measurement using scope in x-y mode.

identical characteristics with respect to both phase and sensitivity. In the high frequency scopes, such as the Model 140A, matching is done with identical plug-in amplifiers.

Matched amplifier characteristics enhance the precision of phase measurements in the x-y mode. A typical sine wave phase measurement is diagrammed in Figure 4. Here, horizontal and vertical amplifier gains are adjusted for equal deflection. The resulting display pattern is an ellipse whose shape indicates the phase angle between the signals at the scope's input. At one extreme this ellipse becomes a straight line slanting towards the right at  $45^\circ$  ( $0^\circ$  phase shift). At the other extreme, it slants to the left at  $45^\circ$  ( $180^\circ$  phase shift). Other values of phase shift lie between these extremes;  $90^\circ$  (or  $270^\circ$ ) phase shift generates a circle. The phase shift is calculated from measurements of the parameters indicated on the diagram.<sup>1</sup> Useful voltage-current phase relationships also can be studied by using an HP current probe as one of the input signals.

### Time bases

Triggering the sweep is quick and easy with HP scopes through the use of automatic triggering. Present adjustments produce synchronized sweeps with little or no adjustment of the front-panel controls. An automatic baseline, present on many HP scopes facilitates setting up the display in the absence of an input signal. The sweep magnifier feature is valuable for close examination of trace segments which occur too late in time after the start of the trace to be examined with faster sweeps.

The delay generator, available with all HP plug-in scopes, produces a delay time between the input trigger and the sweep start. This capability is used in a variety of ways for the study of complex waveforms. One of the modes is Mixed Sweep, shown in Figure 5.

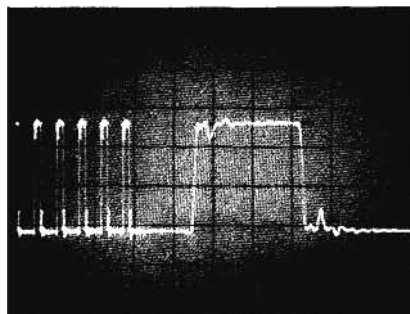

Figure 5. Train of pulses displayed in dual speed Mixed Sweep by an HP delay generator plug-in.

### Plug-in oscilloscopes

Hewlett-Packard plug-in oscilloscopes enable the user to make a very wide variety of measurements with just one oscilloscope, since instrument characteristics can be altered simply by changing the vertical and horizontal plug-ins. Bandwidth, sensitivity, number of channels, and time base all can be tailored to exact needs; other features such as trace recorders may be added at will. All HP plug-in scopes (Models 140A/141A, 175A, 180A) have wide bandwidths for maximum flexibility.

The Models 140A/141A are capable of measuring signals up to 12.4 GHz. The instrument is extremely versatile, since it contains only power supplies, crt, and a calibrator. Everything else is plugged in. With appropriate plug-ins, the 140A/141A can become a dual-channel high-frequency scope, a low-frequency scope with  $10 \mu\text{V}/\text{cm}$  sensitivity, a sampling scope, or even a time domain reflectometer for analyzing broadband systems.

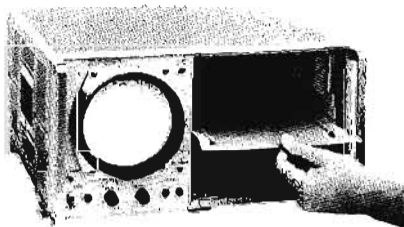

Figure 6. The design of the HP 140A/141A Oscilloscopes allows a double sized dual-axis plug-in to be used when the center shield is removed from the plug-in compartment.

<sup>1</sup>For a direct-reading method of phase shift measurement, the reader is referred to "A Convenient Method for Measuring Phase Shift," HP Application Note No. 29, free on request.

The Model 180A, newest of the HP plug-in scopes, is portable (only 30 pounds including plug-ins) and 100% solid state (except for crt). This instrument uses a new plug-in concept, where the vertical and horizontal units are attached together (mechanically, and electrically) before inserting them into the frame. The  $8 \times 10 \text{ cm}$  crt is 30% bigger than any other high frequency scope, allowing more accurate measurements. This scope also meets high environmental specifications, both electrical and mechanical, over a temperature range of  $-28^\circ\text{C}$  to  $+65^\circ\text{C}$ .

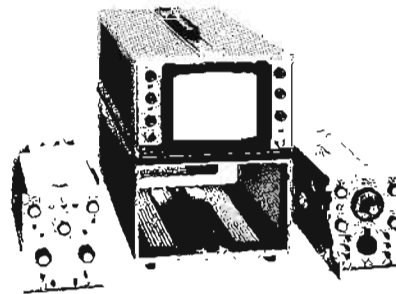

Figure 7. Model 180A features aircraft type frame construction for maximum ruggedness with minimum weight.

The Model 175A is a 50 MHz scope with unusual versatility. It accepts various multi-channel vertical plug-ins, as well as horizontal plug-ins, for recording, and sweep delay.

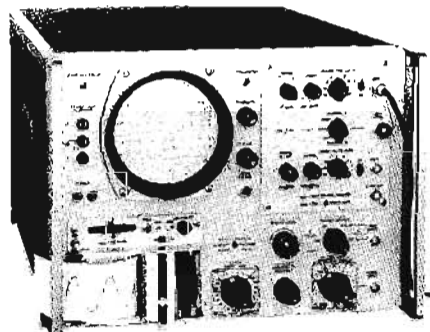

Figure 8. Dual plug-in capability adds unusual versatility to the Model 175A Scope. The Model 1784A plug-in produces strip-chart recordings of displays with pushbutton ease.

### Sampling oscilloscopes

Sampling oscilloscopes, with bandwidths to 12.4 GHz, use a stroboscopic approach to reconstruct the input waveform from samples taken during many recurrences of the waveform, thereby circumventing the bandwidth limitations of conventional CRT's and amplifiers. This technique is illustrated by the waveforms of Figure 9. In reconstructing a waveform, the sampling pulse "turns on" the sampling circuit for an extremely short interval and the waveform voltage at that instant, shown by the dots on the waveform, is measured. The crt spot is positioned vertically to the corresponding voltage amplitude.

The next sample is taken during a subsequent cycle at a slightly later point on the input waveform. The crt spot moves hori-

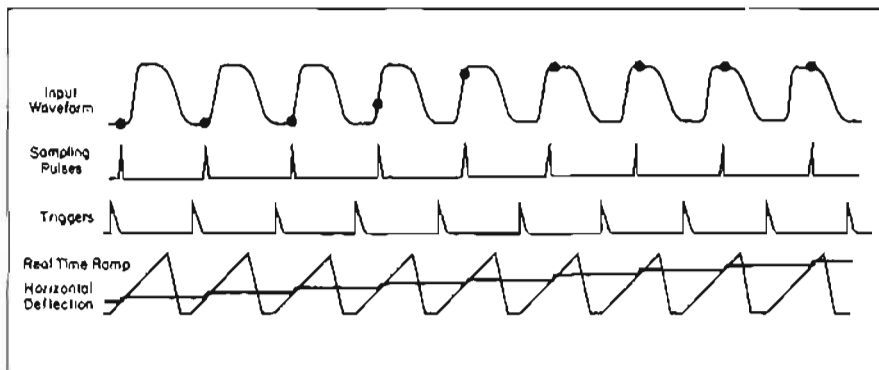
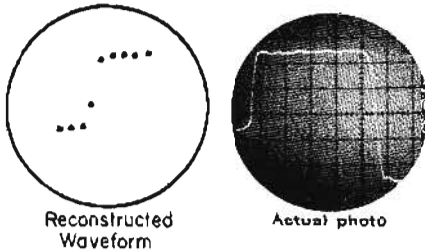

Figure 9. Waveforms, pertinent to operation of sampling oscilloscope. Actual photo has 1000 samples which blend into continuous line.

zontally a short distance and is repositioned vertically to the new voltage. In this way, the scope plots the waveform point by point, as many as 1000 samples being used to reconstruct the waveform.

A bright trace is obtained regardless of sampling rate, sweep speed, or waveform duty cycle, since each crt spot remains "on" during the full interval between samples. Also, small fluctuations on large signals may be examined in detail because of the exceptional dynamic range of the sampling scope. For instance, any part of a 2 V signal may be viewed with 0.4 mV/cm sensitivity by adjusting vertical position.

### Sampling circuit

The unique sampling circuit, developed by HP, minimizes circuit loading with its high input impedance. During a sampling interval, sampling pulses momentarily bias the diodes of the balanced sampling gate in the forward direction, briefly connecting input capacitance to the test point (the balanced bridge minimizes coupling of the sampling pulses back into the test circuit). The capacitance is charged slightly toward the new voltage level. This charge is then amplified to the original value present in the test circuit and fed back to the input. In effect, the circuit detects the "error" signal between the previous and the new samples and nulls out the difference. High sensitivity

and gain stability are thus achieved. All HP wideband sampling scopes feature feed-through inputs for monitoring signals without terminating or otherwise disturbing them. Feed-through inputs also allow for precise Time Domain Reflectometry measurements.

### Dual-trace operation

Separate sampling circuitry and inputs are provided for each channel of the Model 1410A and 1411A Dual-trace Plug-ins. Sampling operations are carried out in both chan-

nels simultaneously. This allows simultaneous display of two input waveforms with no displacement in their phase relationship.

### Circuit measurement considerations

The high-impedance probes supplied as integral parts of the Model 1410A Dual-Trace Amplifier enable circuit probing in the usual sense with minimum circuit disturbance. When working with fast pulse or high-frequency circuits, however, the inductance of any conductor can have an appreciable effect (about 0.025 uH per inch), and stray capacitance can resonate with this inductance. The Model 1410A probes have short, low-inductance probe pins to minimize this effect. Compatible accessories, such as dc blocking capacitors and voltage dividers, are available for extending the usefulness of the probes.

### Other features

The beam finder button, a convenience feature found on HP scopes, simplifies trace centering. Pressing this button reduces the gain of both horizontal and vertical amplifiers while simultaneously brightening and defocusing the trace. In this way, the trace is brought on screen, regardless of the set-

tings of the positioning, intensity and sweep trigger controls.

Reliability through conservative design is built into all HP scopes. They are designed for ease of servicing, with all components readily accessible. Edge-on connectors and plug-in or snap-out circuit boards allow easy removal of entire circuit sections for replacement or repair.

Most HP scopes are packaged in modular cabinets (page 568). These instruments can be stacked on the bench with other HP instruments or quickly converted to rack mounting. A tilting bail raises either end for easier viewing on the bench.

### Selecting an oscilloscope

Choice of an oscilloscope is based largely on considerations of both performance capabilities and versatility. Versatility is greatly enhanced if the scope has plug-in capability, since the scope's performance can be altered by use of the appropriate plug-in. Plug-in capability also enables a scope's performance to be updated as new plug-ins become available. The prospective purchaser should decide, first of all, whether his applications are broad enough to require plug-in versatility.

Bandwidth and deflection factor (sensitivity) of the vertical amplifiers are the primary characteristics which describe an oscilloscope's performance capabilities. Wide bandwidth is obtained at the expense of more complicated circuitry and more expensive cathode-ray tubes. High deflection factor requires more amplifier stages and added refinements for minimizing dc drift and noise.

Hewlett-Packard's general-purpose oscilloscopes make accurate voltage and time measurements on a wide variety of waveforms in the subsonic, audio, ultrasonic and low rf frequency ranges. These scopes are intended for analysis of waveforms in which little importance is attached to frequency components beyond 500 kHz. The dc amplifiers and long sweep rates are suitable for medical and mechanical studies, as well as for low-frequency electrical work. At the same time, fast sweep speeds are provided in these instruments for detailed studies of transient phenomena, vibration effects, audio analysis and other high frequency physical events.

Since these instruments have relatively simple circuitry and construction, they are the most economical type of oscilloscope. In applications such as systems, where the scope performs just one function and the added expense of plug-in flexibility is not needed, the general-purpose oscilloscope provides maximum economy.

In all cases, it is recommended that the customer consult with the local HP field engineer. The field engineers are trained in the use and applications of all HP instruments and can assist in solving the particular applications problem in the most economical way.

## Glossary of oscilloscope terminology

**Accelerating Voltage**—The cathode-to-viewing-screen voltage applied to a cathode ray tube for the purpose of accelerating the electron beam.

**Alternate Mode**—A means of displaying output signals of two or more channels by switching the channels, in sequence, after each sweep.

**Automatic Triggering**—A mode of triggering in which one or more of the triggering circuit controls are preset to conditions suitable for automatically displaying repetitive waveforms. The automatic mode may also provide a recurrent trigger or recurrent sweep in the absence of triggering signals.

**Bandwidth**—A statement of the frequencies defining the upper and lower limits of a frequency spectrum where the amplitude response of an amplifier to a sinusoidal waveform becomes .707 (−3dB) of the amplitude of a reference frequency. When only one number appears, it is taken as the upper limit.

**Chopped Mode**—A time sharing method of displaying output signals of two or more channels with a single cathode ray tube gun, in sequence, at a rate not referenced to the sweep.

**Common Mode Rejection Ratio (CMRR)**—Ratio of the deflection factor for a common-mode signal to the deflection factor for a differential signal.

**Common-Mode Signal**—The instantaneous algebraic average of two signals applied to a balanced circuit, all signals referred to a common reference.

**Common-Mode Signal Maximum**—The largest common-mode signal at which the specified common-mode rejection ratio is valid.

**DC Balance**—An adjustment of circuitry to avoid a change in dc level when changing gain.

**DC Drift (Stability)**—Property of retaining defined electrical characteristics for a prescribed period.

**DC Shift**—An error in transient response with a time constant approaching several seconds.

**Deflection Axis**—The major coordinates passing through the center of the viewing area.

**Deflection Factor (Sensitivity)**—The ratio of the input signal amplitude to the resultant displacement of the indicating spot (e.g., volts/division).

**Delayed Sweep**—A sweep that has been delayed either by a predetermined period or by a period determined by an additional independent variable.

**Differential Amplifier**—An amplifier whose output signal is proportional to the algebraic difference between two input signals.

**Dual-Beam Oscilloscope**—An oscilloscope in which the cathode ray tube produces two separate electron beams that may be individually or jointly controlled.

**Dual Trace**—A mode of operation in which a single beam in a cathode ray tube is shared by two signal channels. See Alternate Mode and Chopped Mode.

**Free-Running Sweep**—A sweep that runs without being triggered and is not synchronized by any applied signal.

**Guarded Input**—Means of connecting an input signal so as to prevent any common mode signal from causing current to flow in the input, thus differences of source impedance do not cause conversion of the common mode signal into a differential signal.

**Input RC Characteristics**—The dc resistance and capacitance to ground present at the input of an oscilloscope.

**Internal Graticule**—A scale for measurement of quantities displayed on the crt whose rulings are a permanent part of the inner surface of the cathode ray tube faceplate.

**Jitter**—An aberration of a repetitive display indicating instability of the signal or of the oscilloscope. May be random or periodic, and is usually associated with the time axis.

**Magnified Sweep**—A sweep whose time per division has been decreased by amplification of the sweep waveform rather than by changing the time constants used to generate it.

**Mixed Sweep**—In a system having both a delaying sweep and a delayed sweep, a means of displaying the delaying sweep to the delaying pickoff and the delayed sweep beyond that point.

**Risetime**—The interval between the instants at which the pulse amplitude first reaches specified lower and upper limits. Unless otherwise stated, these limits shall be 10% and 90% of the pulse's amplitude.

**Single Sweep**—Operating mode for a triggered-sweep oscilloscope in which the sweep must be reset for each operation, thus preventing unwanted multiple displays.

**Sweep**—An independent variable of a display; unless otherwise specified, this variable is a linear function of time, but may be any quantity that varies in a definable manner.

**Sweep Holdoff**—The interval between sweeps during which the sweep and/or trigger circuits are inhibited.

**Time Base**—The sweep generator in an oscilloscope that generates the time function, which is usually linear and expressed in sec/cm.

**Time Base Accuracy**—Accuracy of the time base usually expressed in terms of average rate error as a percent of full scale.

**Trigger**—A pulse used to initiate some function.

**Triggering Level**—The instantaneous level of a triggering signal at which a trigger is to be generated.

**Triggering Slope**—The positive going (+ slope) or negative slope (− slope) portion of a triggering signal from which a trigger is to be derived.

## Cathode ray tube phosphor characteristics

Phosphor	Trace Color		Persistence	Relative Burn Resistance	Relative Brightness
	Under Excitation	After-Glow			
P2	yellowish-green	yellowish-green	medium short	6	6.5
P7	white	yellowish-green	long	3	8
P11	blue	blue	medium short	3	5.4
P31	green	green	medium short	10	10
Description of Persistence			Time to Decay to 10% of Initial Brightness		
medium short			10 microsec to 1 millisecc		
medium			1 millisecc to 100 millisecc		
long			100 millisecc to 1 sec		
Phosphor	Application		Information		
P2	Observing either low- or medium-speed non-recurring phenomena.		After-glow may have useful persistence for over a minute under conditions of adequate excitation and low-ambient illumination.		
P7	Observing either extremely low-speed recurrent phenomena or medium-speed non-recurrent phenomena.		During excitation the trace is white. After excitation the trace is yellowish-green for several minutes.		
P11	For use in all photographic applications.		Trace is high intensity actinic blue.		
P31	Observing either low- or medium-speed non-recurring phenomena.		Highest visual brightness.		



## 450 kHz OSCILLOSCOPE

Easy-to-use, general-purpose 10 mV/cm scope  
Model 120B

The HP Model 120B Oscilloscope is an easy-to-use, general-purpose oscilloscope for both laboratory and industrial applications. It combines accurately calibrated horizontal sweep times and vertical deflection sensitivities with an internal graticule CRT that eliminates parallax error. In addition, the front panel controls are logically grouped by function to simplify operation. The automatic triggering feature synchronizes the sweep circuitry with the displayed

waveform, eliminating time-consuming trigger adjustments. The Hewlett-Packard modular enclosure is equally well suited for bench use or for rack mounting with the hardware provided with each instrument. Moreover, the removable top and bottom covers of the modular enclosure permit access to all components and adjustments within the instrument for easy routine maintenance.

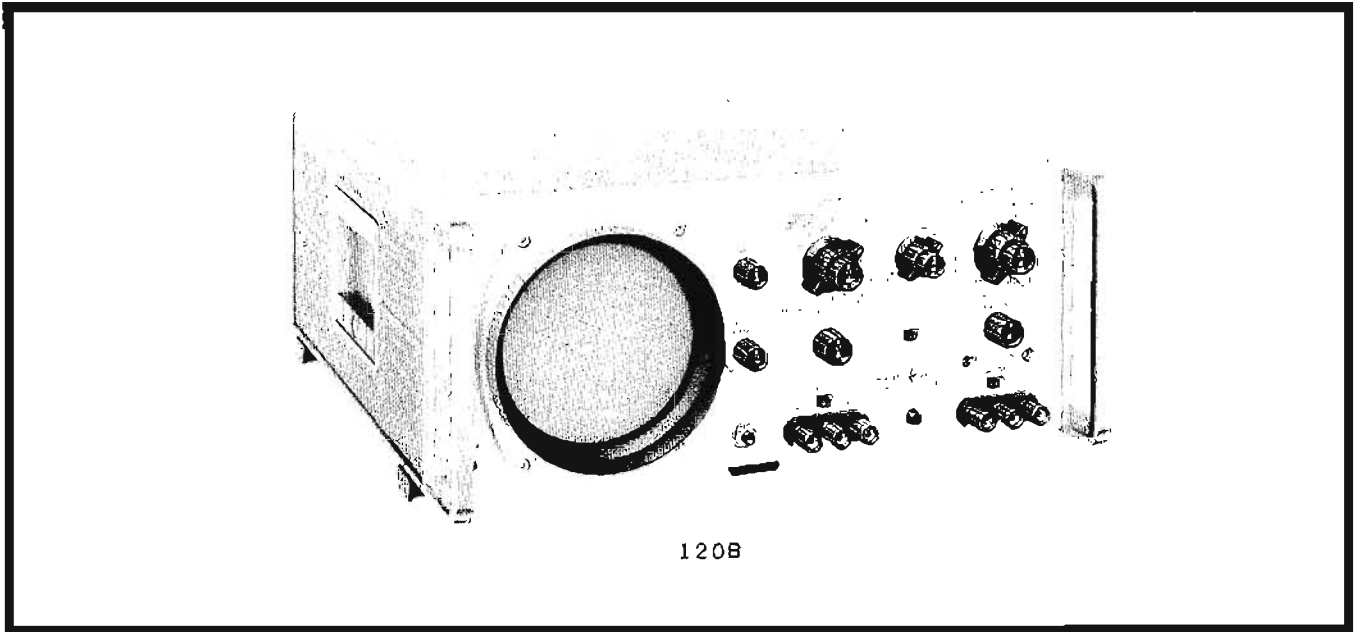

### Specifications

#### Time base

**Range:** 5 $\mu$ sec/cm to 200 msec/cm, 15 ranges in a 1, 2, 5, sequence; accuracy  $\pm 5\%$ ; vernier provides continuous adjustment between steps and extends the 200 msec/cm step to at least 0.5 sec/cm.

**Magnifier:** X5 sweep expansion may be used on all ranges and expands the fastest sweep to 1  $\mu$ sec/cm, expanded sweep accuracy is  $\pm 10\%$ .

**Automatic triggering** (baseline displayed in the absence of an input signal);

**Internal:** 50 Hz to 450 kHz for signals causing 0.5 cm or more vertical deflection; also from line voltage.

**External:** 50 Hz to 450 kHz for signals at least 1.5 volts peak-to-peak.

**Trigger slope:** positive or negative slope of vertical deflection signal; or negative slope of external sync signal.

**Amplitude selection triggering;**

**Internal:** 10 Hz to 450 kHz for signals causing 0.5 cm or more vertical deflection.

**External:** 10 Hz to 450 kHz for signals at least 1.5 volts peak-to-peak.

**Trigger point and slope:** from any point on the vertical waveform presented on CRT, or continuously variable from  $-7$  to  $+7$  volts on the negative slope of external sync signal.

#### Vertical amplifier

**Bandwidth:** dc coupled, dc to 450 kHz; ac coupled, 2 Hz to 450 kHz.

**Deflection factor (sensitivity):** 10 mV/cm to 10 volts/cm in 4 calibrated steps; accuracy  $\pm 3\%$ ; vernier provides continuous adjustment between steps and extends 10 V/cm step to at least 100 V/cm.

**Maximum input:** 500 V peak (dc + ac).

**Internal calibrator:** calibrating signal automatically connected to vertical amplifier for setting amplifier gain, accuracy  $\pm 2\%$ .

**Input RC:** 1 megohm shunted by approximately 50 pF.

**Balanced input:** on 10 mV/cm range; input RC, 2 megohms shunted by approximately 25 pF; common mode rejection at least 40 dB; common mode signal must not exceed  $\pm 3$  volts peak.

**Phase shift:** vertical and horizontal amplifiers have same phase characteristics within  $\pm 2^\circ$  to 100 kHz (with verniers in Cal).

#### Horizontal amplifier

**Bandwidth:** dc coupled, dc to 300 kHz; ac coupled, 2 Hz to 300 kHz.

**Deflection factor (sensitivity):** 0.1 volt/cm to 10 volts/cm in 3 calibrated

steps; accuracy  $\pm 5\%$ ; vernier provides continuous adjustment between steps and extends 10 V/cm step to at least 100 V/cm.

**Input RC:** 1 megohm, nominal, shunted by approximately 100 pF.

#### General

**Cathode ray tube:** mono-accelerator, 2700-volt accelerating potential; aluminized P31 phosphor (other phosphors available, see modifications); etched safety glass face plate reduces glare.

**Graticule:** 10 cm x 10 cm parallax-free internal graticule marked in cm squares; major horizontal and vertical axes have 2 mm sub-divisions.

**Beam finder:** pressing beam finder control brings trace on CRT screen, regardless of settings of horizontal, vertical, or intensity controls.

**Intensity modulation:**  $+20$  volt pulse will blank trace of normal intensity; input terminals on front panel.

**Dimensions:** 16 $\frac{1}{2}$ " wide, 7 $\frac{1}{2}$ " high, 18 $\frac{3}{8}$ " deep overall (426 x 191 x 466 mm); hardware furnished for quick conversion to 7" x 19" (178 x 483 mm) rack mount.

**Weight:** net 29 lbs (13 kg); shipping 35 lbs (15.8 kg).

**Power:** 115 or 230 volts  $\pm 10\%$ ; 50 to 1000 Hz; approximately 95 W.

**Price:** HP Model 120B, \$495.

**Modifications:** CRT phosphors (specify by phosphor number): P31 standard; P2, P7 with amber filter, P11 available, no charge.

**Special order:** chassis slides and adapter kit; fixed slides, order HP Part No. 1490-0714, \$32.50; pivot slides, order HP Part No. 1490-0718, \$40; slide adapter kit for mounting slides on scope, order HP Part No. 1490-0721, \$20.

**Options:** (specify by option number)

05: external graticule CRT with P31 phosphor (P2, P7, P11 available, please specify); in lieu of standard internal graticule, add \$25, includes edge-lighting of external graticule.

06: rear terminals in parallel with front panel terminals, two 3-pin AN connectors for horizontal and vertical signal inputs; BNC for trigger input, add \$30; mating AN connectors supplied.

10: provision for single-sweep operation, as well as conventional triggered sweep, add \$35.

13: plain 3/16" x 7" x 19" front panel for rack mounting only; suitable for installing special handles to match existing equipment in system or console, add \$20

## DUAL-TRACE OSCILLOSCOPE

Economical versatility — 200 kHz 10 mV/cm  
Models 122A, 122AR



## OSCILLOSCOPES

The Model 122A/AR is a dual trace, 200 kHz bandwidth oscilloscope which simplifies observation and measurement of electrical and mechanical equipment performance. It can be used as an ordinary scope with a single trace, or, when a comparison of two quantities is required it can provide two separate traces which in many ways is like having two scopes.

Personnel quickly learn the operation of this instrument and can use it with confidence since it has guaranteed calibration on both its sweep (time base) and voltage amplitude measurements.

Signals may be compared simultaneously and directly due to the twin vertical amplifiers which may be used separately or automatically switched. Input and output signals of amplifiers, filters, and other networks may be viewed simultaneously and transmission or rejection characteristics seen immediately. Since dc coupling is available, very low frequency square-waves may be used for testing, or the scope may be ac coupled to eliminate and unwanted dc signal.

### Specifications

#### Time base

**Range:** 5  $\mu$ sec/cm to 200 msec/cm, 15 ranges in a 1, 2, 5 sequence; accuracy  $\pm 5\%$ ; vernier provides continuous adjustment between steps, and extends the 200 msec/cm step to at least 0.5 sec/cm.

**Magnifier:** X5 sweep expansion may be used on all ranges and expands the fastest sweep to 1  $\mu$ sec/cm; expanded sweep accuracy is  $\pm 10\%$ .

**Automatic triggering (baseline displayed in the absence of an input signal):**

**Internal:** 50 Hz to 250 kHz for signals causing 0.5 cm or more vertical deflection; also from line voltage.

**External:** 50 Hz to 250 kHz for signals at least 2.5 volts peak-to-peak.

**Trigger slope:** positive or negative slope of vertical deflection signals; or negative slope of external sync signals.

**Amplitude selection triggering:**

**Internal:** 10 Hz to 250 kHz for signals causing 0.5 cm or more vertical deflection.

**External:** 10 Hz to 250 kHz for signals at least 2.5 volts peak-to-peak.

**Trigger point and slope:** from any point on the vertical waveform presented on crt; or continuously variable from  $-10$  to  $+10$  volts on negative slope of external sync signal.

#### Vertical amplifiers

**Bandwidth:** dc coupled, dc to 200 kHz, ac coupled, 2 Hz to 200 kHz.

**Deflection factor (sensitivity):** 10 mV/cm to 10 volts/cm in 4 calibrated steps; accuracy  $\pm 3\%$ ; vernier provides continuous adjustment between steps and extends 10 V/cm step to at least 100 V/cm.

**Maximum input:** 500 V peak (dc + ac).

**Internal calibrator:** calibrating signal automatically connected to vertical amplifier for setting amplifier gain; accuracy  $\pm 2\%$ .

**Input RC:** 1 megohm shunted by approximately 50 pF.

**Balanced input:** on 10 mV/cm range; input RC, 2 megohms shunted by approximately 25 pF; common mode rejection at least 40 dB; common mode signal must not exceed  $\pm 3$  volts peak.

**Phase shift:** vertical and horizontal amplifiers have same phase characteristics within  $\pm 2^\circ$  to 100 kHz (with verniers in Cal).

**Isolation:** greater than 80 dB between Channels A and B from dc to 200 kHz.

**Difference input:** both input signals may be switched to one channel to give differential input on all sensitivity ranges; the sensitivity controls may be set separately to allow mixing signals of different levels; common mode rejection is at least 40 dB with both controls in most sensitive range, 30 dB on other ranges.

**Vertical presentation:** control selects, A only, B only, B-A, Alternate, or Chopped.

#### Horizontal amplifier

**Bandwidth:** dc coupled, dc to 200 kHz, ac coupled, 2 Hz to 200 kHz.

**Deflection factor (sensitivity):** 0.1 volt/cm to 10 volts/cm in 3 calibrated steps; accuracy  $\pm 3\%$ ; vernier provides continuous adjustment between steps and extends 10 V/cm step to at least 100 V/cm.

**Input RC:** 1 megohm, nominal, shunted by approximately 100 pF.

#### General

**Cathode ray tube:** mono-accelerator, 3000-volt accelerating potential; aluminized P31 phosphor (other phosphors available, see modifications); etched safety glass face plate reduces glare.

**Graticule:** 10 cm x 10 cm parallax-free internal graticule marked in cm squares; major horizontal and vertical axes have 2 mm sub-divisions.

**CRT plates:** direct connection to crt deflection plates via terminals on rear panel; sensitivity approximately 20 V/cm.

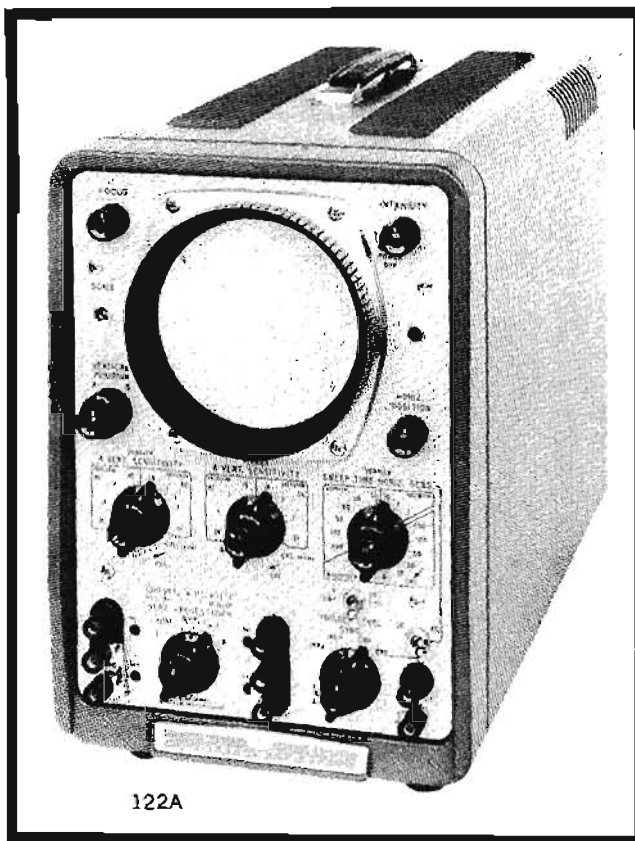

122A

**Intensity modulation:** +20 volt pulse will blank trace of normal intensity; input terminals on rear panel.

**Dimensions:** cabinet: 9 $\frac{3}{4}$ " wide, 15" high, 21 $\frac{1}{4}$ " deep overall (248 x 310 x 540 mm); rack mount: 19" wide, 7" high, 19 $\frac{1}{2}$ " deep behind panel (483 x 178 x 493 mm).

**Weight:** cabinet: net, 35 lbs (15.8 kg); shipping, 45 lbs (20.3 kg); rack mount: net, 34 lbs (11.3 kg); shipping, 49 lbs (22 kg).

**Power:** 115 or 250 volts  $\pm 10\%$ ; 50 to 1000 Hz; approximately 150 W.

**Price:** HP Model 122A (cabinet), \$695; HP Model 122AR (rack mount), \$695, for single sweep operation specify H15 122A or H15-122AR, \$765.

#### Modifications

**CRT phosphors (specify by phosphor number):** P31 standard; P2, P7 with amber filter, P11 available, no charge.

**Options:** (specify by option number)

05 External graticule CRT with P31 phosphor (P2, P7, P11 available, please specify) in lieu of standard internal graticule, add \$25; includes edge-lighting of external graticule.

06 Rear terminals in parallel with front panel terminals; three 3-pin AN connectors for horizontal, vertical, and trigger inputs, add \$40; mating AN connectors supplied.

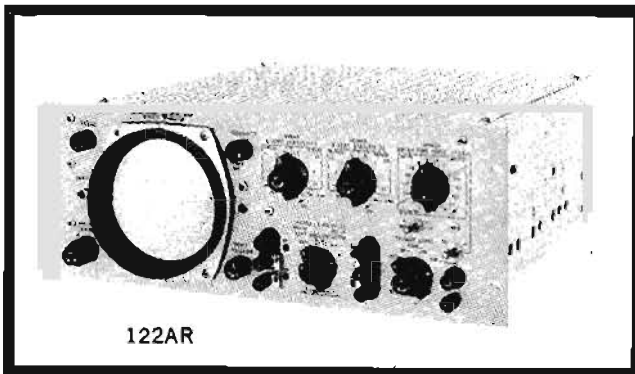

122AR



## 200 $\mu\text{V}/\text{CM}$ OSCILLOSCOPE

Features identical amplifiers for x-y plots  
Model 130C

The HP Model 130C Oscilloscope is a versatile all-purpose instrument for laboratory, production line, industrial process measurements and medical applications. The outputs of rf detectors, strain gauges, transducers and other low-level devices may be viewed directly without preamplification. Calibrated sweeps allow accurate time measurements, and the identical horizontal and vertical amplifiers permit simple and precise measurement of phase.

The Model 130C is easy to operate even by inexperienced personnel. Controls are color coded to front-panel markings and are logically arranged by function. An internal-graticule crt provides a bright, clear, non-glare display without parallax. Automatic triggering minimizes adjustments. Positive pushbutton beam finder immediately locates an off-screen trace.

### Identical amplifiers

Identical horizontal and vertical amplifiers provide a high sensitivity of 200  $\mu\text{V}/\text{cm}$  from dc to 500 kHz and balanced inputs on all ranges. Balanced output signals from low-level transducers, such as those used in industrial and medical fields, can be measured directly without external amplification. The amplifiers also may be used single-ended with ac or dc coupling. Regulated power supplies, high-stability components and extensive feedback insure excellent gain stability and low noise even on the most sensitive ranges. A front-panel switch (Amplifier AC-DC) provides ac coupling between amplifier stages and virtually eliminates all drift—even on the most sensitive range. Phase shift between amplifiers is held to less than  $\pm 1^\circ$  up to 100 kHz for accurate phase measurements.

Probes may be used with both the horizontal and vertical amplifiers, and since the input impedance is constant, the probes will not require recompensation between sensitivity ranges.

### Automatic triggering

Trigger adjustments are minimized with the Model 130C by the automatic triggering feature, which provides a base line in the absence of an input signal. For fast expanded sweep times where the automatic base line would be too dim for observation, a free run mode establishes a bright base line. A trigger level control is located on the front panel so that automatic triggering may be easily locked out if desired, and a preset trigger level established.

### Versatile sweeps

For accurate time measurements, 21 linear direct-reading sweep times from 1  $\mu\text{sec}/\text{cm}$  to 5 sec/cm are available, accurate within  $\pm 3\%$ . A calibrated X2 to X50 magnifier expands the sweep up to 0.2  $\mu\text{sec}/\text{cm}$ , accurate within  $\pm 5\%$ . A vernier control permits continuous adjustment between calibrated ranges and extends the slowest sweep speed to at least 12.5 sec/cm. In addition, a front-panel switch for either normal or single sweep permits observation of single-shot phenomena or random events. Switching to single sweep will disable the sweep circuit after a single sweep so that it can not be retriggered until manually rearmed. A front-panel sweep "armed" light indicates when the sweep is armed and ready to be triggered.

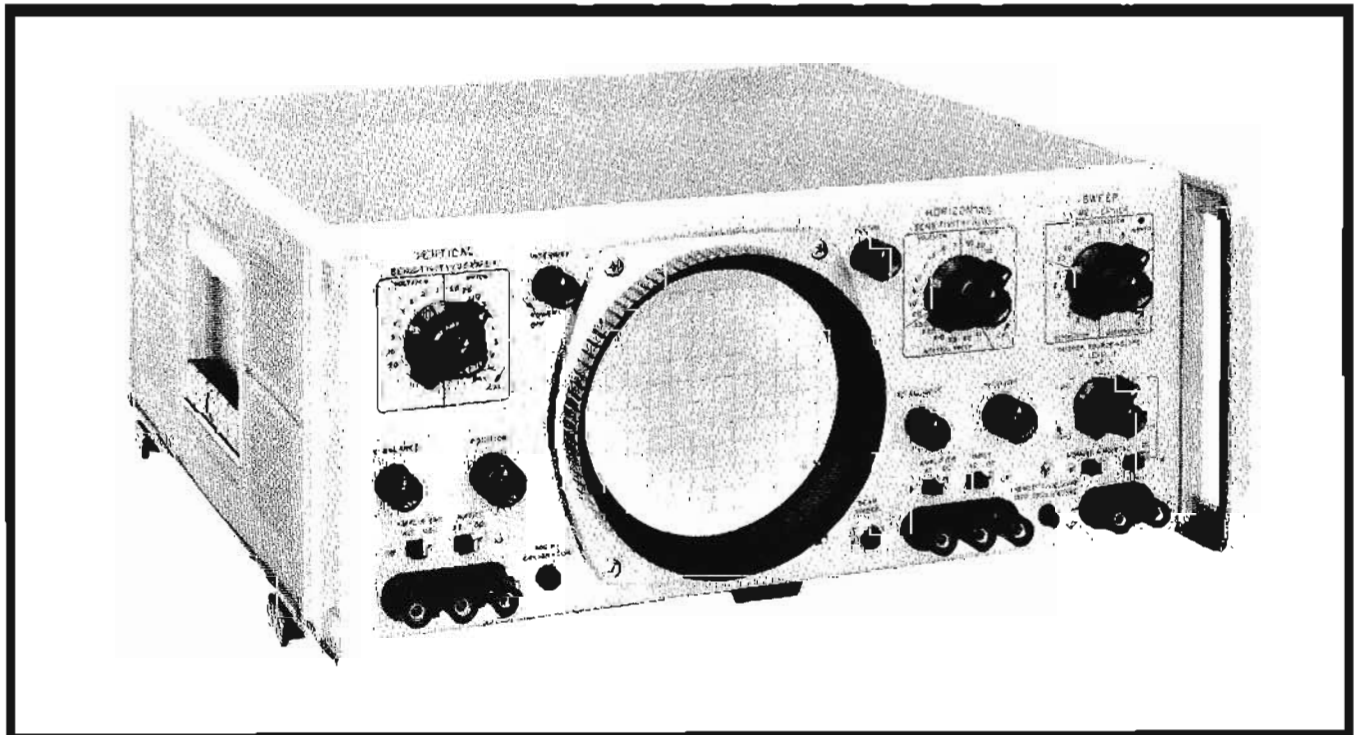



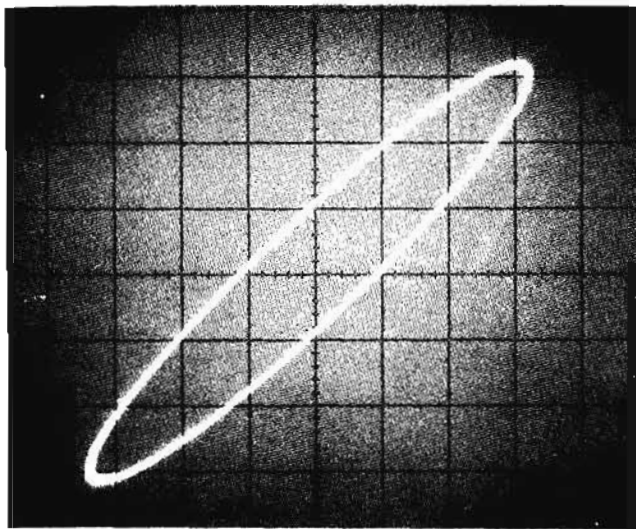

Phase shift measurements are easily made, as a result of the identical horizontal and vertical amplifiers in the Model 130C.

### Specifications

#### Time base

**Range:** 1  $\mu\text{sec}/\text{cm}$  to 5  $\text{sec}/\text{cm}$ , 21 ranges in a 1, 2, 5 sequence; accuracy  $\pm 3\%$ ; vernier provides continuous adjustment between steps and extends the 5  $\text{sec}/\text{cm}$  step to at least 12.5  $\text{sec}/\text{cm}$ .

**Magnifier:** X2, X5, X10, X20, X50; overall sweep accuracy within  $\pm 5\%$  for sweep rates which do not exceed a maximum rate of 0.2  $\mu\text{sec}/\text{cm}$ .

**Automatic triggering (baseline displayed in the absence of an input signal):**

**Internal:** 50 Hz to 500 kHz for signals causing 0.5 cm or more vertical deflection; also from line voltage.

**External:** 50 Hz to 500 kHz for signals at least 0.5 volt peak-to-peak.

**Trigger slope:** positive or negative slope of external sync signal or internal vertical deflection signal.

**Amplitude selection triggering:**

**Internal:** 10 Hz to 500 kHz for signals causing 0.5 cm or more vertical deflection.

**External:** for signals at least 0.5 volt peak-to-peak; dc coupled, dc to 500 kHz; ac coupled, 20 Hz to 500 kHz.

**Trigger point and slope:** from any point on the vertical waveform presented on crt; or continuously variable from  $-10$  to  $+10$  volts on either positive or negative slope of external sync signal.

**Single sweep:** front panel switch permits single sweep operation.

#### Vertical and horizontal amplifiers

**Bandwidth:** dc coupled, dc to 500 kHz; ac coupled (input), 2 Hz to 500 kHz; ac coupled (amplifier), 25 Hz to 500 kHz at 0.2  $\text{mV}/\text{cm}$  deflection factor; lower cut-off frequency ( $f_{co}$ ) is reduced as deflection factor is increased; at 20  $\text{mV}/\text{cm}$ ,  $f_{co}$  is 0.25 Hz; on less sensitive ranges, response extends to dc.

**Deflection factor (sensitivity):** 0.2  $\text{mV}/\text{cm}$  to 20 volts/cm, 16 ranges in a 1, 2, 5 sequence; accuracy  $\pm 3\%$ ; vernier provides continuous adjustment between steps and extends 20  $\text{V}/\text{cm}$  step to at least 50  $\text{V}/\text{cm}$ .

**Maximum input:** 500 V peak (dc + ac).

**Internal calibrator:** calibrating signal (approximately 350 Hz square wave, 5  $\text{mV} \pm 3\%$ ) for setting amplifier gain, is automatically connected to amplifier when sensitivity vernier is set to Cal.

**Input RC:** 1 megohm shunted by approximately 45 pF; constant on all ranges.

**Balanced inputs:** on all sensitivity ranges.

**Common mode rejection (dc to 50 kHz):** at least 40 dB from 0.2  $\text{mV}/\text{cm}$  to 0.1  $\text{V}/\text{cm}$  sensitivities, common mode signal not to exceed 4 volts pk-pk; at least 30 dB from 0.2  $\text{V}/\text{cm}$  to 20  $\text{V}/\text{cm}$  sensitivities, common mode signal not to exceed 4 volts pk-pk on the 0.2  $\text{V}/\text{cm}$  range, 40 volts pk-pk on the 0.5  $\text{V}/\text{cm}$  to 2  $\text{V}/\text{cm}$  ranges, or 400 volts pk-pk on the 5  $\text{V}/\text{cm}$  to 20  $\text{V}/\text{cm}$  ranges.

**Phase shift:** amplifiers have same phase characteristics within  $\pm 1^\circ$  to 100 kHz (with verniers in Cal, and equal input sensitivities).

### General

**Calibrator:** approximately 350 Hz, 500  $\text{mV} \pm 2\%$  provided through jack on front panel.

**Cathode ray tube:** mono-accelerator, 3000-volt accelerating potential; aluminized P31 phosphor (other phosphors available, see modifications); etched safety glass face plate reduces glare.

**Graticule:** 10 cm x 10 cm parallax-free internal graticule marked in cm squares; major horizontal and vertical axes have 2 mm sub-divisions.

**Beam finder:** pressing beam finder control brings trace on crt screen, regardless of setting of horizontal, vertical, or intensity controls.

**Intensity modulation:** +20 volt pulse will blank trace of normal intensity; input terminals on rear panel.

**Dimensions:** 16 $\frac{3}{4}$ " wide, 7 $\frac{1}{2}$ " high, 18 $\frac{3}{8}$ " deep overall (426 x 191 x 466 mm); hardware furnished for quick conversion to 7" x 19" (178 x 483 mm) rack mount.

**Weight:** net, 31 lbs (14 kg); shipping, 38 lbs (17.1 kg).

**Power:** 115 or 230 volts  $\pm 10\%$ ; 50 to 1000 Hz; approximately 90 W.

**Price:** HP Model 130C, \$695.

**Modifications:** crt phosphors (specify by phosphor number); P31 standard; P2, P7 with amber filter, P11 available, no charge.

**Special order:** chassis slides and adapter kit; fixed slides, order HP part No. 1490-0714, \$32.50; pivot slides, order HP part No. 1490-0718, \$40; slide adapter kit for mounting slides on scope, order HP part No. 1490-0721, \$20.

**Options (specify by option number):**

05 external graticule crt with P31 phosphor (P2, P7, P11 available, please specify) in lieu of standard internal graticule, add \$25; includes edge-lighting of external graticule.

06 rear terminals in parallel with front panel terminals; two 3-pin AN connectors for horizontal and vertical signal inputs, BNC for trigger input, add \$40; mating AN connectors supplied.

13 plain 3/16" x 7" x 19" panel for rack mounting only; suitable for installing special handles to match existing equipment in system or console, add \$20.





## DUAL-BEAM OSCILLOSCOPE

Two completely independent beams

Model 132A

The HP Model 132A Dual-Beam Oscilloscope is designed to perform many electronic, scientific, bio-medical and mechanical measurements. Its  $100 \mu\text{V}/\text{cm}$  sensitivity, 500 kHz bandwidth, two completely independent beams, and low microphonics and drift assure ease and accuracy in a wide variety of applications.

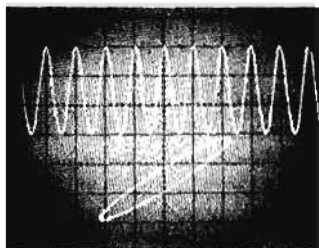

Figure 1. Simultaneous x-y and time plots are possible with Model 132A, since it has two completely independent CRT beams.

Unusual versatility is available with the Model 132A through its many different display capabilities. Functions such as pressure vs. volume, the outputs of vector cardiographs, or phase shift may be shown in x-y form on one channel, while related rate functions are displayed vs. time on the other. Also, slow and fast signals may be viewed simultaneously on different sweep speeds, or the same signal may be studied at two different sweep rates.

The Model 132A is ideal for use in areas of vibration or noise, since the amplifiers have very low microphonics and dc drift. Each input stage has nuvistors tubes contained in a shock-mounted block of aluminum. Besides isolating the nuvistors from vibration, the block also serves to keep the temperature of the tubes identical, thus providing excellent dc stability.

Differential operation is provided on all ranges for the elimination of common mode pickup such as 60-Hz hum. Rejection ratios as high as 20,000 to 1 (86 dB) assure completely clean waveforms even in the presence of high common mode interference.

Waveforms look the same from range to range with the

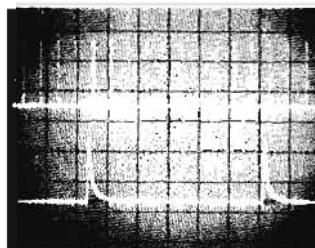
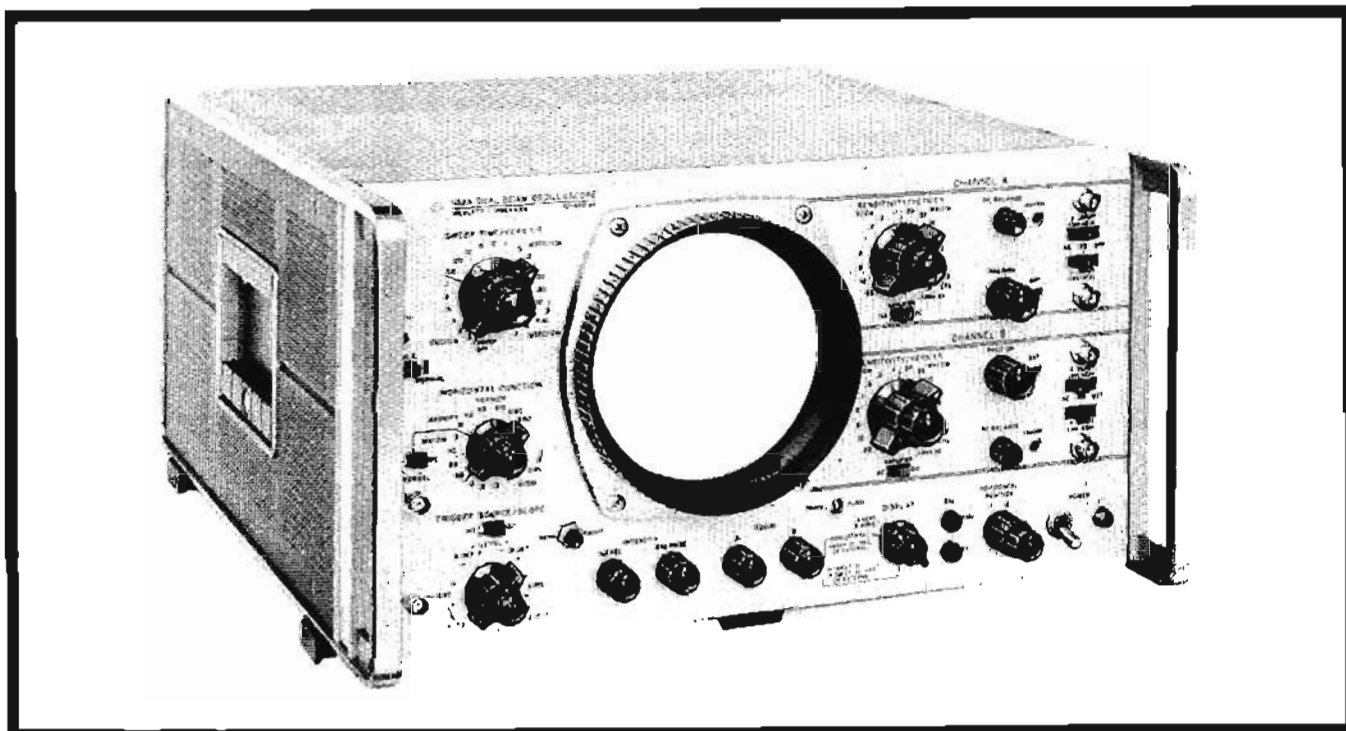

Figure 2. The same signal may be shown at two different sweep speeds with the slower sweep intensified to show location of fast sweep.

Model 132A, since the full 500 kHz bandwidth is retained at sensitivities from  $1 \text{ mV}/\text{cm}$  through  $20 \text{ V}/\text{cm}$ . At the most sensitive range,  $100 \mu\text{V}/\text{cm}$ , bandwidth becomes 150 kHz.

Each vertical amplifier has an output at the rear panel of the Model 132A, allowing the user to monitor displays with an rms voltmeter, or drive a tape recorder.

The 3.5 kV aluminized CRT provides displays that are brighter than those previously available, making the Model 132A an excellent instrument for observing single-shot phenomena. A beam finder facilitates locating an off-screen trace by simply depressing a front-panel control. The internal graticule of the CRT eliminates parallax error, thus increasing measurement accuracy.



## Specifications

### Time base

**Range:** may be selected for both beams, or one beam only with the other driven externally; 1  $\mu\text{sec}/\text{cm}$  to 5  $\text{sec}/\text{cm}$ , 21 ranges in a 1, 2, 5 sequence; vernier provides continuous adjustment between steps, and extends 5  $\text{sec}/\text{cm}$  step to at least 12.5  $\text{sec}/\text{cm}$ .

**Magnifier:** X2, X5, X10, X20, X50; may be selected for both channels together, or Channel B only; vernier provides continuous adjustment between steps; with same vertical input applied to both channels, any portion of the display may be magnified on Channel B and the magnified portion will be intensified on Channel A display.

### Automatic triggering (baseline displayed in the absence of an input signal):

**Internal:** 50 Hz to 500 kHz for signals causing 0.5 cm or more vertical deflection; selected from either channel input, or from line voltage.

**External:** 50 Hz to 500 kHz, for signals at least 0.5 volt peak-to-peak.

**Trigger slope:** positive or negative slope of external sync signal or internal vertical deflection signals.

### Amplitude selection triggering

**Internal:** for signals causing 0.5 volt or more vertical deflection; dc coupled, dc to 500 kHz; ac coupled, 20 Hz to 500 kHz; selected from either channel signal, or from line voltage.

**External:** for signals at least 0.5 volt peak-to-peak; dc coupled, dc to 500 kHz; ac coupled, 20 Hz to 500 kHz.

**Trigger point and slope:** from any point on vertical waveform presented on CRT or continuously variable from  $-10$  to  $+10$  volts on either positive or negative slope of external signal.

**External trigger input RC:** ac coupled, 0.01  $\mu\text{F}$  in series with 1 megohm; dc coupled, 1 megohm.

**Sweep delay time:** a pretrigger of approximately 1  $\mu\text{sec}$  will allow the leading edge of non-recurrent waveform to be visible.

**Single sweep:** front panel switch and pushbutton permit single sweep operation.

### Identical vertical amplifiers

**Deflection factor (sensitivity):** 100  $\mu\text{V}/\text{cm}$  to 20  $\text{V}/\text{cm}$ ; 17 ranges in a 1, 2, 5 sequence; accuracy  $\pm 3\%$ ; verniers provide continuous adjustment between steps, and extend 20  $\text{V}/\text{cm}$  steps to at least 50  $\text{V}/\text{cm}$ .

**Bandwidth:** dc to greater than 500 kHz (10% to 90% rise time less than 0.7  $\mu\text{sec}$ ) on ranges 20  $\text{V}/\text{cm}$  through 1  $\text{mV}/\text{cm}$ , decreasing to greater than 150 kHz at 100  $\mu\text{V}/\text{cm}$ , input may be ac coupled with 2 Hz lower cutoff; amplifier may be ac coupled (to eliminate drift) with 2.5 Hz lower cutoff at 100  $\mu\text{V}/\text{cm}$ , decreasing to 0.1 Hz at 20  $\text{mV}/\text{cm}$ .

**Differential input:** differential input may be selected on all attenuator ranges; the following common mode signals will not overdrive the amplifier:

Deflection factor	Input: DC	Input: AC
0.1 $\text{mV}/\text{cm}$ to 0.2 $\text{V}/\text{cm}$	$\approx 2$ V	4 V peak-to-peak
0.5 $\text{V}/\text{cm}$ to 2.0 $\text{V}/\text{cm}$	$\approx 20$ V	40 V peak-to-peak
5.0 $\text{V}/\text{cm}$ to 20 $\text{V}/\text{cm}$	$\approx 200$ V	400 V peak-to-peak

When a sine wave not exceeding the above limits is simultaneously applied from a low-impedance source to the dc coupled amplifier inputs, the vertical amplifiers have the following rejection ratios:

Deflection factor	60 Hz	1 kHz	50 kHz
0.1 $\text{mV}/\text{cm}$	86	80	74
1 $\text{mV}/\text{cm}$	66	66	66
0.2 $\text{V}/\text{cm}$	40	40	40
0.5 $\text{V}/\text{cm}$ to 20 $\text{V}/\text{cm}$	30	30	30

With input ac coupled, maximum CMR at 60 Hz is 60 dB.

**Inputs:** two BNC connectors for + and - polarities; AC, DC, or Off may be selected for each input; input RC in 1 megohm shunted by 50 pF, constant on all ranges; max. input voltage is  $\pm 500$  V peak (dc + ac).

**Amplifier outputs:** a single-ended, dc-coupled output for each amplifier is provided on the rear panel; voltage output is approx. 2  $\text{V}/\text{cm}$  from a 2 k ohm source impedance; bandwidth is approx. 500 kHz with a non-capacitive load.

### External horizontal amplifier

**Functions:** may be used on both beams simultaneously, or on one beam only while the other is sweeping unmagnified.

**Deflection factor (sensitivity):** 5  $\text{mV}/\text{cm}$  to 2  $\text{V}/\text{cm}$ ; 9 ranges in a 1, 2, 5 sequence; accuracy  $\pm 3\%$ ; vernier provides continuous adjustment between steps and extends 2  $\text{V}/\text{cm}$  step to at least 5  $\text{V}/\text{cm}$ .

**Bandwidth:** dc to greater than 300 kHz (with vernier in Cal); ac coupled, lower limit is 2 Hz.

**Input:** BNC connector; input RC, 1 megohm shunted by 50 pF, constant on all ranges; max. input voltage,  $\pm 500$  volts peak (dc + ac).

### X-Y operation

**Single beam:** x-y curve tracing; one of the vertical amplifiers can be switched to the horizontal deflection plates of the other beam, allowing x-y operation of the two identical amplifiers; the unused beam is positioned off screen; relative phase shift between + inputs is within  $\pm 2^\circ$  for frequencies up to 50 kHz with verniers in Cal and equal input sensitivities.

**Dual-beam:** x-y plots can be made between the external horizontal amplifier and the B vertical amplifier while the other beam is operating normally with the sweep and A vertical amplifier, or, dual plots can be made using the external horizontal amplifier driving both beams; relative phase shift is normally within  $\pm 2^\circ$  for frequencies up to 10 kHz with vernier in Cal and equal input sensitivities.

### General

**Calibrator:** approximately 350 Hz square wave, 0.5 V and 0.5 mV, provided through jacks on front panel; accuracy  $\pm 2\%$ .

**Cathode ray tube:** mono-accelerator, 3500-volt accelerating potential; aluminized P2 phosphor (other phosphors available, see modifications); dual gun and two independent sets of vertical and horizontal deflection plates; etched safety glass face plate reduces glare.

**Graticule:** 10 cm x 10 cm parallax-free internal graticule marked in cm squares; display area for each beam is 8 cm x 10 cm, with 6 cm vertical overlap in center; vertical and horizontal axes for each beam have 2 mm subdivisions.

**Beam finder:** pressing beam finder control brings both traces on CRT screen, regardless of vertical, horizontal, or intensity control settings.

**Intensity modulation:** +20 volt pulse will blank traces of normal intensity; input terminals on rear panel; input time constant is approximately 125  $\mu\text{sec}$  (9400 pF and 13.5 k ohms).

**Dimensions:** 16 $\frac{3}{4}$ " wide, 9" high, 18 $\frac{3}{8}$ " deep overall (426 x 229 x 466 mm); hardware furnished for quick conversion to 19" x 8 $\frac{3}{4}$ " x 16 $\frac{3}{8}$ " behind panel (483 x 222 x 416 mm) rack mount.

**Weight:** net 43 lbs (19.4 kg); shipping 55 lbs (24.8 kg).

**Power:** 115 or 230 volts  $\pm 10\%$ ; 50 to 1000 Hz; approximately 130 W.

**Price:** HP Model 132A, \$1275.

**Modifications:** CRT phosphors (specify by phosphor number); P7, P11, P31 available; no charge.

**Special order:** chassis slides and adapter kit; fixed slides, order HP Part No. 1490-0714, \$32.50; pivot slides, order HP Part No. 1490-0718, \$40; slide adapter kit for mounting slides on scope, order HP Part No. 1490-0721, \$20.

**Options:** (specify by option number)

- 05 External graticule CRT with P2 phosphor (P7, P11, P31 available, please specify) in lieu of standard internal graticule, includes edge-lighting of external graticule, add \$25.
- 06 Rear terminal in parallel with front panel terminals; 3-pin AN connectors for vertical signal inputs; BNC for horizontal and trigger signal inputs, mating AN connectors supplied, add \$45.

# OSCILLOSCOPES



## PLUG-IN OSCILLOSCOPE

One scope to do nearly any measurement task  
Model 140A

The HP Model 140A Oscilloscope, used with the Model 1400-series plug-ins, provides both high-frequency and high-sensitivity capabilities for general oscilloscope applications, as well as a sampling capability. The total number of 1400-series plug-ins now available (seventeen) clearly illustrates the versatility of the Model 140A/1400-series combination. In addition, the design of the Model 140A has allowed for the use of a single, double-sized plug-in to supply information to both axes of deflection. Double-size plug-ins are available for testing broadband systems by means of pulse reflection (Model 1415A) and for use with swept

frequency oscillators (Model 1416A).

The Model 140A is a main-frame which contains the basic essential functional circuitry for both low-and high-frequency applications, as well as those for the sampling technique. It contains a post-accelerator CRT with its associated power supplies and control circuitry, and the dc supplies required to power the Model 1400-series plug-ins. The plug-ins contain all of the circuitry necessary to produce beam deflection, and work directly into the CRT of the Model 140A.

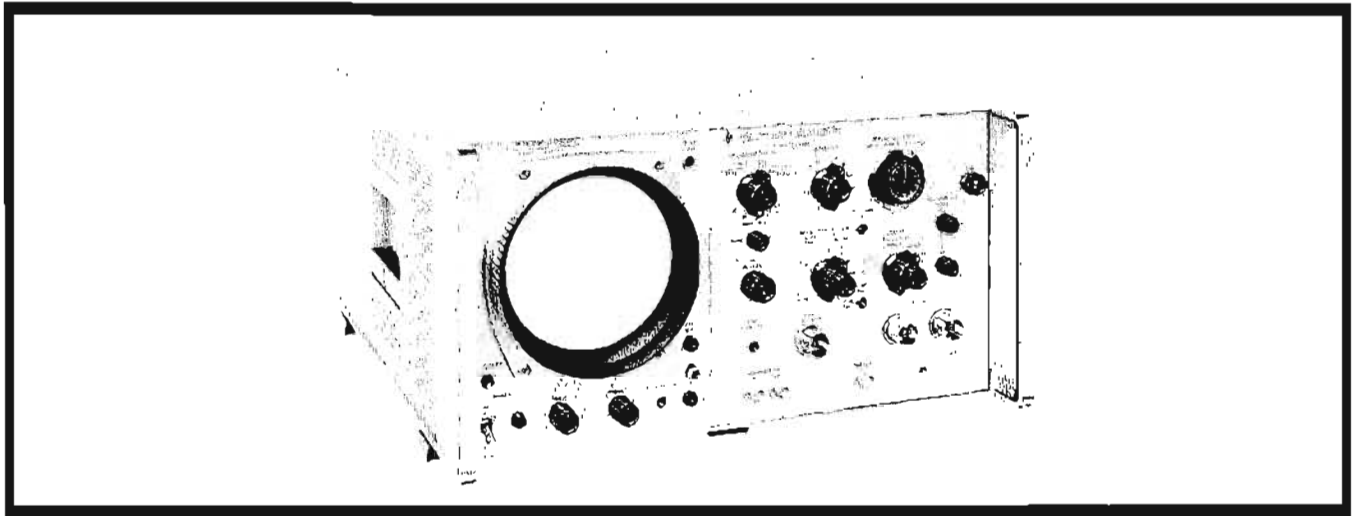

### Specifications

**Plug-ins:** accepts Model 1400-series plug-ins; upper compartment for horizontal axis and lower compartment for vertical axis; center shield may be removed to accommodate a single dual-axis Model 1400-series unit.

**Cathode ray tube:**

**Type:** post-accelerator, 7500-volt accelerating potential; aluminized P31 phosphor, (other phosphors available, see modifications); etched safety glass face plate reduces glare.

**Graticule:** 10 cm x 10 cm parallax-free internal graticule marked in cm squares; major horizontal and vertical axes, and second and tenth horizontal graticule lines have 2 mm subdivisions.

**Intensity modulation:** +20 volt pulse will blank trace of normal intensity; input terminals on rear panel.

**Warranty:** CRT warranted for one year.

**Writing rate:** (using HP Model 197A Camera with f/1.9 lens and Polaroid® 3000 speed film).

P31 Phosphor: 300 cm/ $\mu$ sec.

P11 Phosphor: 430 cm/ $\mu$ sec.

**Calibrator:**

**Type:** line-frequency rectangular signal, approximately 0.5  $\mu$ sec rise time.

**Voltage:** two outputs: 1 volt and 10 volts peak-to-peak,  $\pm 1\%$  from 15°C to 35°C,  $\pm 3\%$  from 0°C to 55°C.

**Beam finder:** pressing beam finder control brings trace on CRT screen regardless of settings of horizontal, vertical or intensity controls.

**Power requirements:** 115 or 230 volts  $\pm 10\%$ , 50 to 60 Hz, normally less than 285 watts (varies with plug-in units used).

**Dimensions:** 16 $\frac{3}{4}$ " wide, 9" high, 18 $\frac{3}{8}$ " deep overall (426 x 229 x 466 mm); hardware furnished for quick conversion to 8 $\frac{3}{4}$ " x 19" rack mount, 16 $\frac{3}{8}$ " deep behind panel (344 x 483 x 416 mm).

**Weight:** without plug-ins, net 37 lbs (16,7 kg); shipping 45 lbs (20 kg).

**Price:** HP Model 140A (without plug-ins), \$595.

**Modifications:** CRT phosphors (specify by phosphor number), P31 standard; P2, P7 with amber filter, P11 available; no charge.

**Special order:** chassis slides and adapter kit; fixed slides, order HP Part No. 1490-0714, \$32.50; pivot slides, order HP Part No. 1490-0718, \$40; slide adapter kit for mounting slides on scope, order HP Part No. 1490-0721, \$20.

**Blank plug-ins:** half size, Model 10477A, \$25; full size, Model 10478A, \$30.

# VARIABLE PERSISTENCE, STORAGE

Three scopes in one  
Model 141A



## OSCILLOSCOPES

The HP Model 141A Oscilloscope provides a versatility never before equaled in a single instrument. Using the Model 1400-Series plug-ins, it provides all of the high-frequency, high-sensitivity, and sampling capabilities of the Model 140A, as well as being a variable persistence scope, and a storage scope.

Persistence of the Model 141A display may be continuously varied from 1/5 second to more than 1 minute, producing controlled-decaying, easy-to-view traces. The persistence can be adjusted to match the sweep time of any signal, regardless of repetition rate or frequency, with no

flicker from "erase flashes". Traces can be made to linger long enough so that the entire signal is on screen, yet fade fast enough so that successive traces do not overlap. There is no wait for a new display to be traced after erase. Automatic integration of repetitive signals can be easily accomplished by adding successive low-level traces until a bright display is built up; then, if desired, the display can be stored. Display trends can be viewed by using long persistence to superimpose or stack successive displays. Refer to the next page for additional applications.

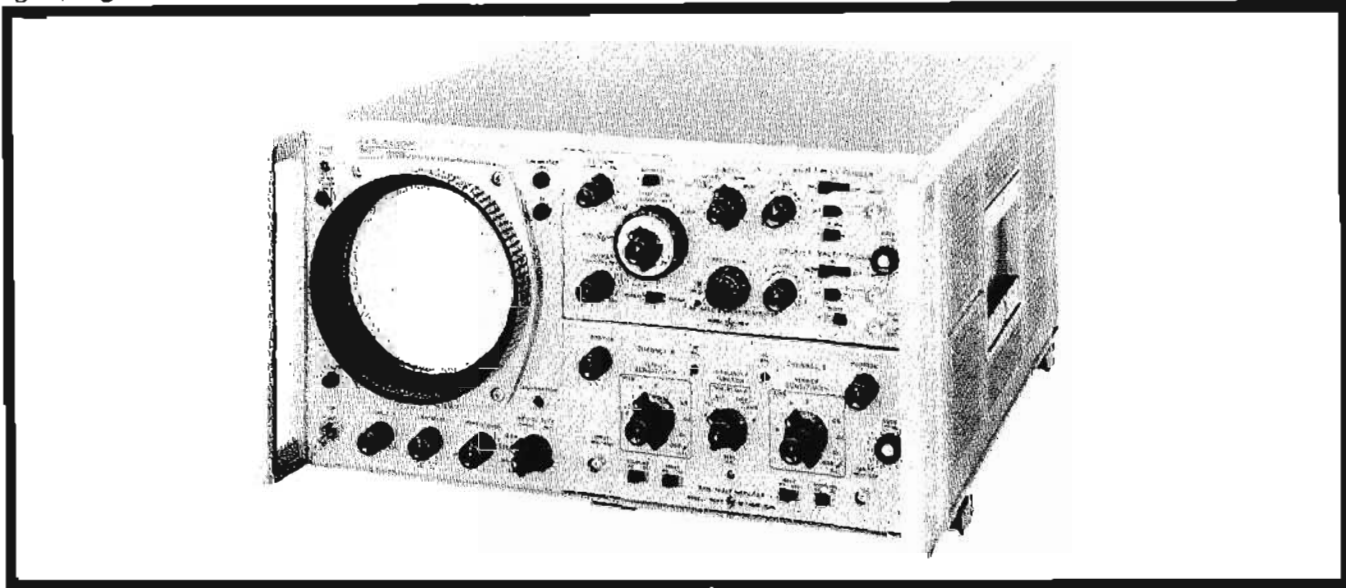

### Specifications

**Plug-ins:** same as Model 140A.

#### Cathode ray tube:

**Type:** post-accelerator storage tube, 7350-volt accelerating potential; aluminized P31 phosphor; etched safety glass face plate reduces glare.

**Graticule:** 10 x 10 divisions (approximately 9.4 x 9.4 cm) parallax-free internal graticule; 5 subdivisions per major division on major horizontal and vertical axes, and on second and tenth horizontal graticule lines.

**Intensity modulation:** +20 volt pulse will blank trace of normal intensity; input terminals on rear panel.

**Warranty:** CRT specifications (persistence, writing rate, brightness, storage time) warranted for one year.

#### Persistence:

**Normal:** natural persistence of P31 phosphor (approximately 0.1 second).

#### Variable:

**Normal writing rate mode:** continuously variable from less than 0.2 second to more than one minute (typically to two or three minutes).

**Max writing rate mode:** typically variable from 0.2 second to 15 seconds.

**Erase:** manual; erasure takes approximately 100 msec; scope ready to record immediately after erasure (see options for remote erase).

**Writing rate (conventional operation):** (using HP Model 197A Camera with f/1.9 lens and Polaroid® 3000 speed film): 100 cm/μsec.

#### Writing rate (Storage):

**Normal mode:** greater than 20 cm/msec.

**Max. mode:** greater than 1 cm/μsec.

#### Storage time:

	NORMAL Writing Rate Mode	MAX. Writing Rate Mode
STORE Mode (dim display)	longer than 1 hour	typically 15 minutes
VIEW Mode (bright display)	longer than 1 minute (typically 2 or 3 minutes)	typically 15 seconds

**Brightness:** greater than 100 foot-lamberts in NORMAL or VIEW; typically 5 foot-lamberts in STORE.

#### Calibrator:

**Beam finder:**

**Power requirements:** } same as Model 140A

#### Dimensions:

**Weight:** net, 40 lbs (18 kg); shipping, 51 lbs (23 kg).

**Price:** HP Model 141A (without plug-ins), \$1275.

**Options:** (specify by option number).

09: Remote erase. BNC input on rear panel; shorting to ground for at least 50 msec erases screen; input draws 20 mA from ground through a 600-ohm impedance to a -12 volt supply. Add \$25.

**Special order:** chassis slides and adapter kit; fixed slides, order HP Part No. 1490-0714, \$32.50; pivot slides, order HP Part No. 1490-0718, \$40; slide adapter kit for mounting slides on scope, order HP Part No. 1490-0721, \$20.

®Polaroid® by Polaroid Corporation.

# OSCILLOSCOPES



## APPLICATIONS: VARIABLE PERSISTENCE & STORAGE

Variable persistence is of special usefulness in presenting slowly swept signals as in mechanical or bio-medical investigations. With continuously variable trace fade-time, slowly swept traces can be kept continuously on display by adjusting persistence to match sweep time. For the first time, persistence values much over a few seconds are available, so traces never before presentable on a scope may now be shown.

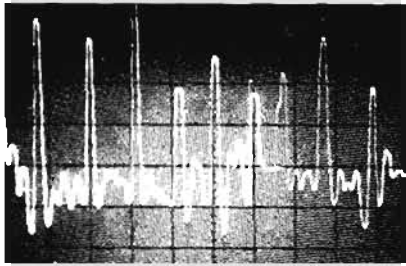

Persistence adjusted so old sweep fades just in time to clear screen for new sweep arriving.

Flicker has been a bothersome effect with slow and medium-slow sweeps; by varying the persistence, one can remove flicker from a presentation at any rate which previously caused this annoyance.

Brightening of low duty-cycle repetitive signals may be accomplished by using long persistence settings. When persistence is several times the sweep period, successive traces add, and a bright presentation can be built up; then, if desired, it may be stored. Meaningless random variations in successive repetitive signals will be de-emphasized by the same process. One-shot departures from the repetitive wave will not add, but the significant trend elements will, and thus emerge brightly.

Superimposition of successive sweeps will display trends in the subject observed, earlier traces being clearly distinguished by their declining brightness. The effect of successive small adjustments on the subject under examination may likewise be conveniently compared.

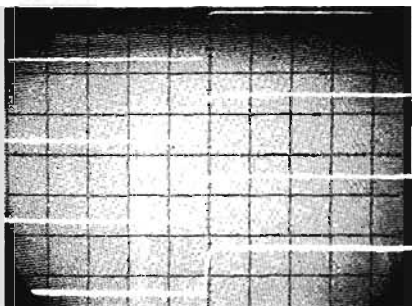

Using long persistence setting, dim portions of repetitive trace are made clearly visible. In this picture the trace was moved downward after each multiple exposure to illustrate growth in visibility.

Detailed resolution of any short sections of long, slow sweeps is greatly aided both by variable persistence and by storage. Achieving highest possible resolution in Time Domain Reflectometry (TDR) measurements calls for precisely this combination of abilities. The Model 1415A plug-in easily measures the characteristics of long lengths of transmission line, using this technique.

The Model 141A will serve all the uses for which previous storage scopes have proved valuable. Its differences from earlier instruments further expand its usefulness. The background is dark when displaying stored traces on the Model 141A, making faint portions of stored traces readily visible. Further, any of the traces which may be built up, using the variable-persistence feature, may also be stored intact; the user is not restricted only to traces which may be produced in the conventional operating mode. The stored trace is displayed without degradation or fuzziness, preserving its original form for later observation.

The unusual ability of the Model 141A to store traces for hours or days, when power is turned off, makes it possible to

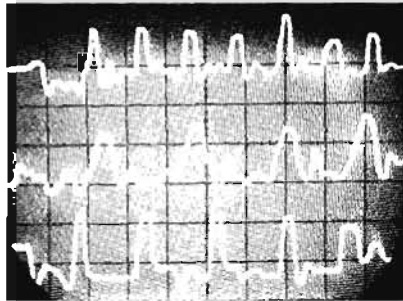

Three traces which occurred at different times were stored, so simultaneous comparison could be made without a camera (photo is a single exposure).

compare observations over very long periods. One practical use would be comparisons from night to morning, when life tests are under way. New traces can be superimposed over those stored while the scope was off. The stored image, in the off condition, has proved remarkably stable and recoverable with substantially no degradation. Instruments have been shipped across-country, the pattern emerging clearly after the process.

One unusual application emerges from the automatic storage which occurs when power to the scope is removed. In much research, and in many industries, safety devices remove power when predetermined limits are exceeded. With the Model 141A continuously displaying some critical parameter, it will, if also

turned off by the automatic safety devices, retain a record of as much as one minute of the phenomena which preceded the power break.

Another unique feature of the Model 141A is its ability to display a gray scale. Most storage scopes display "black and white" only — a lighter trace on a darker background with no intermediate shades of gray. With the Model 141A, four or five separate intensities can normally be distinguished, allowing the plotting and storage of three variables; X, Y, and intensity.

### VARIABLE PERSISTENCE: HOW IT WORKS

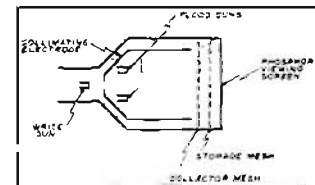

Variable persistence is achieved through the use of a special CRT driven by unique erase circuitry. The CRT is a simple conventional CRT containing a number of special electrodes.

The storage mesh, just behind the phosphor screen, is a conducting mesh covered with a highly resistive coating of magnesium fluoride. The write gun (the same gun that produces a trace in a conventional oscilloscope) etches a positively charged pattern on the storage mesh by knocking electrons loose (secondary emission). Because of the excellent insulating property of the magnesium fluoride, this charged pattern "stays put" and does not spread to adjacent areas.

Now that the trace is stored on the mesh, some means is needed to view it. To do this, flood guns are placed in the CRT which spray low velocity electrons toward the screen. Most of them are picked up by the collector mesh and never get to the phosphor screen. However, in the area near the stored positive charge on the storage mesh, the positive field pulls some of the flood gun electrons through the storage mesh. These continue on and hit the phosphor, producing a visible trace.

To erase the screen, a negative voltage is applied to the storage mesh, washing away the stored positive charge. To obtain variable persistence, the erase voltage is applied in the form of pulses. By varying the width of these pulses, the rate of erase is varied. The persistence knob is simply the width control on the erase pulse generator.

## DUAL TRACE AMPLIFIERS

Bandwidths to 20 MHz  
Models 1401A, 1405A, 1402A



## OSCILLOSCOPES

The Model 1401A has two 450 kHz channels, each with a sensitivity of 1 mV/cm. In the dual-trace modes, the sweep may be triggered internally from Channel A only, allowing stable traces and accurate time measurements.

The Model 1405A provides dual-trace 5 MHz at 10 cm deflection. The two channels may be added algebraically or, by a reversal of the Channel A polarity switch, the differential signal may be observed.

The Model 1402A provides bandwidth capability of 20 MHz with 5 mV/cm sensitivity. It also has a built-in delay line, following the trigger take-off, allowing the leading edge of fast-rise signals to be viewed. Internal syncing from Channel A allows convenient, accurate time measurements.

### Specifications, Model 1401A

**Mode of operation:** (1) Channel A alone, (2) Channel B alone, (3) Channel A and Channel B displayed on alternate sweeps, (4) Channel A and Channel B displayed by switching at approx. 100 kHz, with trace blanking during switching, (5) Channel A minus Channel B.

**Bandwidth:** Input and Amplifier coupling set to dc, dc to 450 kHz (0.8  $\mu$ sec risetime); Input set to dc and Amplifier set to ac, dc to 450 kHz for deflection factors from 50 mV/cm to 10 V/cm; from 1 mV/cm to 20 mV/cm, lower cutoff depends on the deflection factor: approximately 0.5 Hz (to 450 kHz) at 20 mV/cm and 10 Hz (to 450 kHz) at 1 mV/cm; Input set to ac and Amplifier set to dc, 2 Hz to 450 kHz.

**Deflection factor (sensitivity):** each channel; 1 mV/cm to 10 V/cm, 14 ranges in a 1, 2, 5 sequence; accuracy  $\pm 3\%$ ; vernier provides continuous adjustment between steps and extends 10 V/cm step to at least 25 V/cm.

**Phase shift:** when used with another Model 1401A, less than 2° relative phase shift up to 50 kHz with X and Y deflection factors the same, and verniers in Cal.

**Common mode rejection:** both inputs may be switched to one channel to give differential input; cmr at least 40 dB on 1 mV/cm to 0.1 V/cm ranges, signal not to exceed 4 V pk-pk; at least 30 dB on 0.2 V/cm to 10 V/cm ranges, signal not to exceed 40 V pk-pk on 0.2, 0.5, and 1 V/cm ranges or 400 V pk-pk on 2, 5 and 10 V/cm ranges; measured with 1 kHz sine wave.

**Input RC:** 1 megohm shunted by 45 pF.

**Maximum input:** 600 volts peak (dc + ac).

**Internal calibrator:** line frequency square wave, 6 cm pk-pk; displayed when vernier is set to Cal; accuracy  $\pm 3\%$ .

**Display polarity:** + up or - up, selectable for Channel A.

**Weight:** net, 5 lbs (2.3 kg); shipping, 7 lbs (3.2 kg).

**Price:** HP Model 1401A, \$375.

### Specifications, Model 1405A

**Mode of operation:** (1) Channel A alone, (2) Channel B alone, (3) Channel A and Channel B displayed in alternate sweeps, (4) Channel A and Channel B displayed by switching at approx. 100 kHz, with trace blanking during switching, (5) Channel A and Channel B added algebraically, polarity of Channel A may be inverted to obtain differential operation.

**Bandwidth:** dc coupled, dc to 5 MHz (70 nsec risetime); ac coupled, 2 Hz to 5 MHz (the lower limit is extended to approx. 0.2 Hz with an X10 probe).

**Deflection factor (sensitivity):** each channel; 5 mV/cm to 10 V/cm, 11 ranges in a 1, 2, 5 sequence; accuracy  $\pm 3\%$ ; vernier provides continuous adjustment between steps and extends 10 V/cm step to at least 25 V/cm.

**Common mode rejection:** at least 40 dB on 5, 10, and 20 mV/cm ranges, at least 30 dB on 50 mV/cm to 10 V/cm ranges; common mode signal not to exceed 50 cm (e.g., 0.5 volt on 10 mV/cm range) or a frequency of 50 kHz.

**Input RC:** 1 megohm shunted by 43 pF.

**Maximum input:** 600 volts peak (dc + ac).

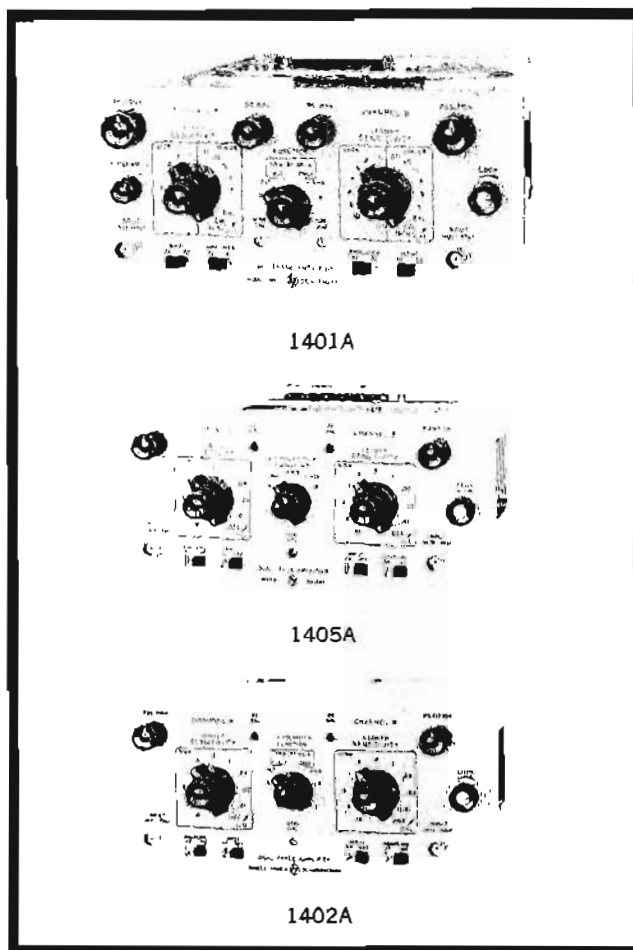

**Weight:** net, 4 lbs (1.8 kg); shipping, 7 lbs (3.2 kg).

**Price:** HP Model 1405A, \$325.

**Special order:** double-size, single-channel, X-Y only version of Model 1405A; order K05-1405A; price, \$325.

### Specifications, Model 1402A

**Mode of operation:** (1) Channel A alone, (2) Channel B alone, (3) Channel A and Channel B displayed on alternate sweeps, (4) Channel A and Channel B displayed by switching at approx. 100 kHz, with trace blanking during switching, (5) Channel A and Channel B added algebraically, polarity of Channel A may be inverted to obtain differential operation.

**Bandwidth:** (6 cm reference signal) dc coupled, dc to 20 MHz; ac coupled, 2 Hz to 20 MHz.

**Risetime:** less than 20 nsec with 6 cm step input.

**Deflection factor (sensitivity):** each channel; 5 mV/cm to 10 V/cm, 11 ranges in a 1, 2, 5 sequence; accuracy  $\pm 3\%$ ; vernier provides continuous adjustment between steps and extends 10 V/cm step to at least 25 V/cm.

**Signal delay:** signal is delayed so that leading edge of fast-rise signals is visible at start of sweep.

**Common mode rejection:** (in B-A mode) at least 40 dB on 5, 10, and 20 mV/cm ranges, at least 30 dB on 50 mV/cm to 10 V/cm ranges; common mode signal not to exceed 150 cm (e.g., 150 volts on 1 V/cm range) or a frequency of 500 kHz.

**Input RC:** 1 megohm shunted by 43 pF.

**Maximum input:** 600 volts peak (dc + ac).

**Weight:** net, 6 lbs (2.7 kg); shipping, 8 lbs (3.6 kg).

**Price:** HP Model 1402A, \$575.





## DIFFERENTIAL AMPLIFIERS

Make accurate measurements of microvolt signals  
Models 1400A, 1403A

The Model 1400A Differential Amplifier has a maximum deflection factor of 100  $\mu\text{V}/\text{cm}$ , and a bandwidth from dc to 400 kHz for measuring the output of strain gauges, transducers, and other low level signals without external preamplification. Even on the most sensitive ranges, drift is low, and accurate dc measurements are possible. Where the dc reference is not important, the amplifier may be ac coupled between stages to eliminate all drift.

The HP Model 1403A Guarded Differential Amplifier combines 10  $\mu\text{V}/\text{cm}$  sensitivity with a guarded input for 106 dB common mode rejection, allowing accurate measurements of low-level differential signals. The guard achieves high CMR by protecting both the differential input amplifier and the two leads to the test point with a floating shield. The shield may be driven either internally by the common mode signal obtained from the amplifier for full 106 dB rejection, or externally from the signal source for high CMR (106 dB) even with unbalanced source impedances.

### Specifications, Model 1400A

#### Bandwidth:

**Upper limit:** 400 (0.9  $\mu\text{sec}$  risetime), 40, or 4 kHz.

**Lower limit:** Input and Amplifier set to dc: dc; Input set to dc and Amplifier set to ac: dc from 20 V/cm to 50 mV/cm, approx 0.1 Hz on 20 mV/cm increasing with deflection factor to approx 20 Hz at 0.1 mV/cm; Input set to ac and Amplifier set to dc: 2 Hz.

**Deflection factor (sensitivity):** 100  $\mu\text{V}/\text{cm}$  to 20 V/cm. 17 ranges in a 1, 2, 5 sequence; accuracy  $\pm 3\%$ ; vernier provides continuous adjustment between steps and extends 20 V/cm step to at least 50 V/cm.

**Phase shift:** when used with another Model 1400A, less than  $2^\circ$  relative phase shift up to 50 kHz with X and Y deflection factors the same, and verniers in Cal.

**Common mode rejection:** differential input may be selected on all ranges; CMR at least 40 dB on 0.1 mV/cm to 0.2 V/cm ranges, signal not to exceed 4 V pk-pk; at least 30 dB on 0.5 V/cm to 20 V/cm ranges, signal not to exceed 40 V pk-pk on 0.5, 1, and 2 V/cm ranges or 400 V pk-pk on 5, 10, and 20 V/cm ranges; measured with 1 kHz sine wave.

**Input RC:** 1 megohm shunted by 45 pF.

**Maximum Input:** 600 volts peak (dc + ac).

**Internal calibrator:** line frequency square wave, 6 cm pk-pk; displayed when vernier is set to Cal; accuracy  $\pm 3\%$ .

**Weight:** net, 4 lbs (1.8 kg); shipping, 7 lbs (3.2 kg).

**Price:** HP Model 1400A, \$250.

### Specifications, Model 1403A

**Input modes:** (1) input A single-ended, (2) input B single-ended and inverted, (3) A-B differential, (4) Off disconnects inputs and grounds input amplifier, (5) CMR and (6) Cal for calibrating the instrument; A and B inputs, guard, and chassis ground are brought out through a special guarded connector; guard is normally driven by internal common mode signal amplifier; with unbalanced source impedances, the guard may be driven externally, preserving high CMR.

**Bandwidth:** 0.1 Hz to 400 kHz (0.9  $\mu\text{sec}$  risetime) (to 200 kHz at 10  $\mu\text{V}/\text{cm}$  and to 300 kHz at 20  $\mu\text{V}/\text{cm}$ ); upper and lower limits may be independently selected; lower: 0.1, 1, 10, and 100 Hz; upper: max (greater than 400 kHz), 100, 10, 1, and 0.1 kHz.

**Deflection factor (sensitivity):** 0.01 mV/cm to 100 mV/cm, 13 ranges in a 1, 2, 5 sequence; accuracy  $\pm 3\%$ ; vernier pro-

vides continuous adjustment between steps and extends 100 mV/cm step to at least 250 mV/cm.

**Phase shift:** when used with another Model 1403A, less than  $2^\circ$  relative phase shift up to 50 kHz with X and Y deflection factors the same, and verniers in Cal.

**Common mode rejection:** differential input may be selected on all ranges; with a balanced input impedance and the Guard Drive in Ext, CMR may be adjusted to the values below for up to 5 V pk-pk, 45 Hz to 3 kHz (for Int. CMR is 6 dB less than shown below).

Deflection factor (mV/cm)	Common mode rejection (dB)
0.01 to 0.2	106
0.5, 1, 2	86
5, 10, 20	66
50, 100	46

Typical CMR with an unbalanced source impedance when using Guard Drive Ext on most sensitive ranges:

Unbalance	60 Hz	120 Hz	1 kHz	10 kHz
100 ohms	100 dB	100 dB	100 dB	90 dB
1 k ohms	100 dB	100 dB	90 dB	70 dB
10 k ohms	80 dB	80 dB	70 dB	50 dB

**Input RC:** 10 megohms shunted by approx 60 pF.

**Maximum input:** 600 volts peak (dc + ac) on A and B inputs, 10 volts on Guard input.

**Noise:** 20  $\mu\text{V}$  pk-pk at 100 kHz, noise is reduced as bandwidth is reduced.

**Internal calibrator:** line frequency square wave, 100 mV pk-pk; displayed when input selector is set to Cal; accuracy  $\pm 3\%$ .

**Weight:** net, 4 lbs (1.8 kg); shipping, 7 lbs (3.2 kg).

**Accessories furnished:** 6-ft double-shielded extension cable, and a 4-terminal binding post adapter.

**Price:** HP Model 1403A, \$475.

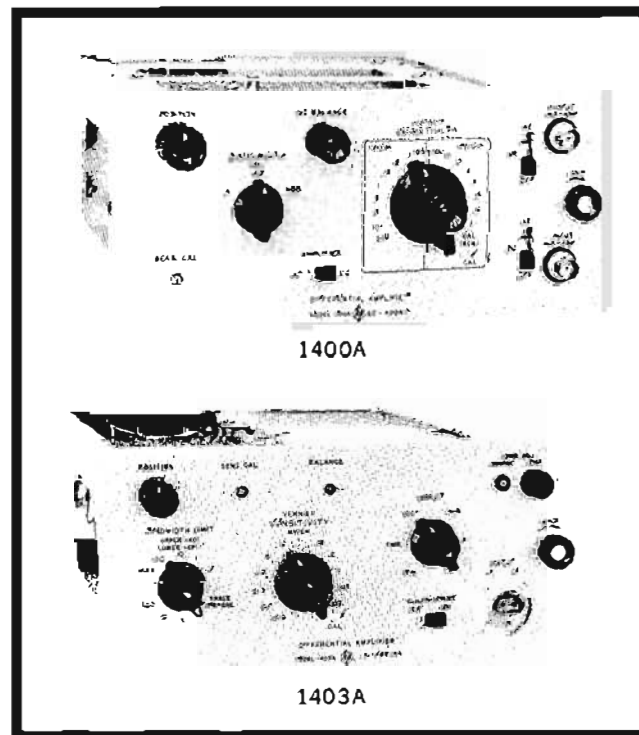



## DIFFERENTIAL AMPLIFIERS

50  $\mu\text{V}/\text{cm}$ , with virtually no drift  
Models 1407A, 1406A



## OSCILLOSCOPES

The Model 1407A Differential Amplifier provides 50  $\mu\text{V}/\text{cm}$  sensitivity with dc stabilized operation. Drift is virtually eliminated with a special dc stabilization circuit. A dc offset control is provided for bucking out dc levels present in the circuit under test that may drive the signal off-screen beyond the range of the position control. Signals of only a few hundred  $\mu\text{V}$  amplitude may be measured in the presence of dc levels up to a few hundred mV, providing maximum resolution and accuracy. Differential input and high common mode rejection eliminate troublesome CMR signals such as 60-Hz hum.

The Model 1406A Differential Amplifier offers a calibrated dc offset capability in addition to 50  $\mu\text{V}/\text{cm}$  sensitivity, dc stabilization, and wide dynamic range. The calibrated offset feature allows the unit to be used as an accurate voltmeter. Readout is to four significant figures, with front panel lights indicating the decimal point. The Model 1406A supplies up to 10 V offset on the 50  $\mu\text{V}/\text{cm}$  range, increasing to 600 V on less sensitive ranges. With these capabilities, the user can measure signal amplitudes to a fraction of a percent. The technique is to position the top of the waveform to mid-screen (with the offset controls) and take a reading. This is then repeated for the bottom of the waveform, with the difference between the two offset readings being the desired amplitude.

### Specifications, Model 1407A

#### Bandwidth:

**Upper limit:** selectable; 5, 25, 100 kHz, and Max (400 kHz for 20 V/cm to 100  $\mu\text{V}/\text{cm}$  ranges, 0.9  $\mu\text{sec}$  risetime; or 300 kHz for 50  $\mu\text{V}/\text{cm}$  range).

**Lower limit:** dc coupled input, dc; ac coupled input, 2 Hz.

**Deflection factor (sensitivity):** 50  $\mu\text{V}/\text{cm}$  to 20 V/cm, 17 ranges in a 1, 2, 5 sequence; accuracy  $\pm 3\%$ ; vernier provides continuous adjustment between steps and extends 20 V/cm step to at least 50 V/cm.

**Amplifier output:** approx. 1 V/cm, dc coupled, single-ended, dc level approx. 0 V, output impedance less than 100 ohms, dynamic range  $\pm 5$  V.

**Drift:** drift correction occurs at 3 Hz for 50 msec/cm speeds and faster, 1.5 Hz on 0.1 sec/cm speeds and slower.

**Long term drift:** less than  $\pm 0.2$  cm or less than  $\pm 20$   $\mu\text{V}/200$  hours, whichever is greater.

**Temperature drift:** less than  $\pm 0.2$  cm or less than  $\pm 50$   $\mu\text{V}$ , whichever is greater, over a temperature range of 0°C to 55°C.

**Range to range shift:** dc stabilization maintains a fixed baseline reference within  $\pm 1$  cm on crt over entire deflection factor range, after a 3-minute warm-up.

**Positioning:** baseline can be positioned continuously or in calibrated steps of 0,  $\pm 5$  cm, and  $\pm 10$  cm; accuracy  $\pm 3\%$ .

**DC offset:** uncalibrated dc offset is provided in both single-ended and differential operation; the max amount of offset obtainable, referenced to the input, varies with deflection factor approx. as follows: 0.2 V at 50  $\mu\text{V}/\text{cm}$ , increasing to 0.5 V at 10 mV/cm, 5 V at 100 mV/cm, 50 V at 1 V/cm, and 600 V at 20 V/cm; offset dc drift is less than  $\pm 20$   $\mu\text{V}/\text{hr}$  at constant ambient temperature, or less than  $\pm 100$   $\mu\text{V}$  for ambient temperature change of 0°C to 55°C.

**Differential input:** may be selected on all ranges; offset capability is maintained in differential operation.

**Common mode rejection:** ( $\pm 5$  V pk-pk input, dc coupled, 50  $\mu\text{V}/\text{cm}$  to 20 mV/cm) dc to 60 Hz, 80 dB; 60 Hz to 10 kHz, 60 dB; max input without overload: 50  $\mu\text{V}/\text{cm}$  to 20 mV/cm,  $\pm 10$  V pk-pk; 50 mV/cm to 2 V/cm,  $\pm 100$  V pk-pk;

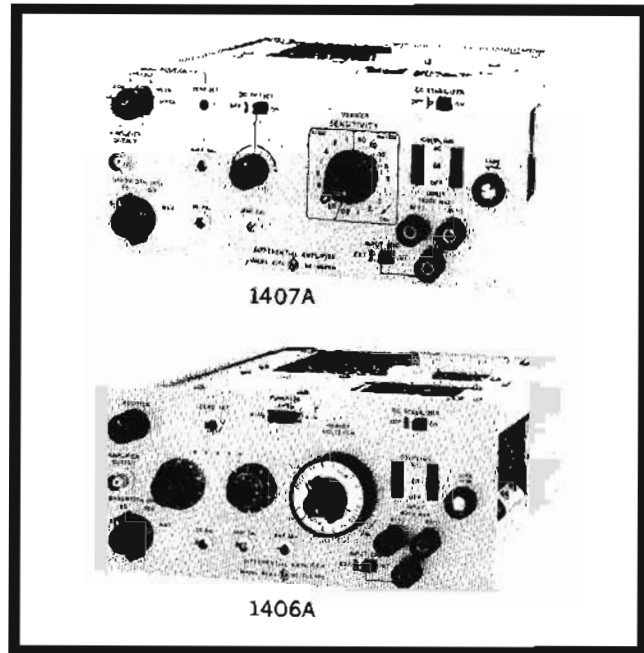

5 V/cm to 20 V/cm,  $\pm 600$  V pk-pk.

**Dynamic range:** dynamic signals of less than  $\pm 50$  cm of deflection can be displayed without distortion.

**Input RC:** 1 megohm shunted by 90 pF.

**Maximum input:** 100 volts peak (dc + ac) for 0.5 mV/cm to 20 mV/cm ranges, 600 volts peak (dc + ac) for 50 mV/cm to 20 V/cm ranges.

**X-Y operation:** two Model 1407A's can be used to provide stabilized X-Y presentations.

**Time base compatibility:** the Model 1407A may be used directly with Models 1422A and 1423A; Model 1420A's below serial 441-01326, and Model 1421A's below serial 545-00651 must be modified for use with the Model 1407A (order kits 01420-69502 for the Model 1420A, \$12.50; or 01421-69501 for the Model 1421A, \$20).

**Weight:** net, 5 lbs (1.8 kg); shipping 7 lbs (3.2 kg).

**Price:** HP Model 1407A, \$625.

### Specifications, Model 1406A

Specifications for the Model 1406A are identical to those of the Model 1407A with the following exceptions.

**Positioning:** baseline can be positioned  $\pm 10$  cm using continuous adjustment control.

**DC offset:** offset is applied to the B (—) input.

**Readout:** 4-digit resolution with lighted decimal indicators.

**Ranges:**  $\pm 0.1$ , 1, 10, 100, 1000 V; up to  $\pm 10$  V offset can be used on all ranges; up to  $\pm 100$  V can be used on 0.5 mV/cm to 20 V/cm, and  $\pm 600$  V on 5 mV/cm to 20 V/cm.

**Accuracy:**  $\pm 0.15\%$  of indicated value plus 0.05% of full scale offset range.

**Differential input:** may be selected on all ranges; single-ended operation is used when employing offset.

**Input RC:** 1 megohm shunted by 100 pF.

**Maximum input:** 600 volts peak (dc + ac), except on 0.05 mV/cm to 20 mV/cm ranges and 0.1, 1, and 10 V offset ranges, where max input is 100 V.

**Price:** HP Model 1406A, \$850.



## TIME BASES

Sweep speeds to 20 nsec/cm  
Models 1422A, 1420A, 1423A

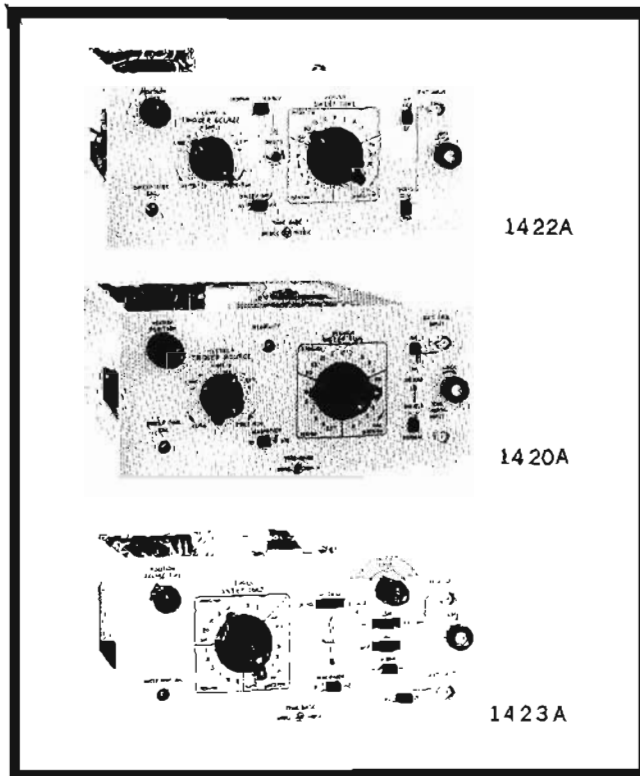

These Time Base plug-ins supply sweep time, trigger, and horizontal input functions for the Model 140A/141A Oscilloscopes, and feature automatic triggering and a single sweep mode.

## Specifications, Model 1422A

**Range:** 1  $\mu\text{sec}/\text{cm}$  to 5 sec/cm, 21 ranges in a 1, 2, 5 sequence; accuracy  $\pm 3\%$ ; vernier provides continuous adjustment between steps and extends the 5 sec/cm step to at least 12.5 sec/cm.

**Magnifier:** X5, overall accuracy  $\pm 5\%$ ; expands 1  $\mu\text{sec}/\text{cm}$  speed to 200 nsec/cm.

**Automatic triggering:** (baseline displayed in the absence of an input signal).

**Internal:** 50 Hz to 500 kHz for signals causing 0.5 cm or more vertical deflection; also from line signal.

**External:** 50 Hz to 500 kHz for signals at least 0.5 V pk-pk.

**Trigger slope:** positive or negative slope of external sync signal or internal vertical deflection signal.

**Amplitude selection triggering:**

**Internal:** dc or 10 Hz to 500 kHz (depending on vertical system) for signals causing 0.5 cm or more vertical deflection.

**External:** for signals at least 0.5 V pk-pk; dc coupled, dc to 500 kHz; ac coupled, 10 Hz to 500 kHz; max. input, 600 V pk (dc + ac).

**Trigger point and slope:** from any point on the vertical waveform presented on crt; or continuously variable from -10 to +10 volts on external sync signal; positive or negative slope.

**Single sweep:** front panel switch permits single sweep operation.

**Horizontal input:**

**Bandwidth:** dc coupled, dc to 400 kHz; ac coupled, 20 Hz to 400 kHz.

**Deflection factor (sensitivity):** vernier permits continuous adjustment from approx. 0.8 V/cm to 2.5 V/cm.

**Input RC:** 1 megohm shunted by approx. 150 pF.

**Weight:** net 5 lbs (2.3 kg); shipping 7 lbs (3.2 kg).

**Price:** HP Model 1422A, \$225.

## Specifications, Model 1420A

**Range:** 0.5  $\mu\text{sec}/\text{cm}$  to 5 sec/cm, 22 ranges in a 1, 2, 5 sequence; accuracy  $\pm 3\%$ ; vernier provides continuous adjustment between steps and extends the 5 sec/cm step to at least 12.5 sec/cm.

**Magnifier:** X10, overall accuracy  $\pm 5\%$ ; expands 0.5  $\mu\text{sec}/\text{cm}$  speed to 50 nsec/cm.

**Automatic triggering:** (baseline displayed in the absence of an input signal).

**Internal:** 40 Hz to 500 kHz for signals causing 0.5 cm or more vertical deflection; also from line signal.

**External:** 40 Hz to 500 kHz for signals at least 0.5 V pk-pk.

**Trigger slope:** positive or negative slope of external sync signal or internal vertical deflection signal.

**Amplitude selection triggering:**

**Internal:** 10 Hz to 10 MHz for signals causing 0.5 cm or more vertical deflection; decreasing sensitivity to 20 MHz.

**External:** for signals at least 0.5 V pk-pk; dc coupled, dc to 10 MHz; ac coupled, 10 Hz to 10 MHz (both decreasing sensitivity to 20 MHz); max. input, 600 V pk (dc + ac).

**Trigger point and slope:** from any point on the vertical waveform presented on crt; or continuously variable from -7 to +7 volts on external sync signal; positive or negative slope.

**Single sweep:** front panel switch permits single sweep operation.

**Horizontal input:**

**Bandwidth:** dc to better than 1.5 MHz (typically).

**Deflection factor (sensitivity):** vernier permits continuous adjustment from approx. 50 mV/cm to 5 V/cm.

**Input RC:** 1 megohm shunted by approx. 50 pF.

**Weight:** net 5 lbs (2.3 kg); shipping 7 lbs (3.2 kg).

**Price:** HP Model 1420A, \$325.

## Specifications, Model 1423A

**Range:** 0.2  $\mu\text{sec}/\text{cm}$  to 5 sec/cm, 23 ranges in a 1, 2, 5 sequence; accuracy  $\pm 3\%$ ; vernier provides continuous adjustment between steps and extends the 5 sec/cm step to at least 12.5 sec/cm.

**Magnifier:** X10, overall accuracy  $\pm 5\%$ ; expands 0.2  $\mu\text{sec}/\text{cm}$  speed to 20 nsec/cm.

**Automatic triggering:** (baseline displayed in the absence of an input signal) same as Normal, except lower limit is 40 Hz for both ac and dc coupling.

**Normal triggering:**

**Internal:** dc coupled: dc (with Models 1406A/1407A) to 15 MHz for signals causing 0.5 cm or more vertical deflection, to 20 MHz for 1 cm signals; ac coupled: 10 Hz to 15 MHz for 0.5 cm signals, to 20 MHz for 1 cm signals; ACF: approx. 2 kHz to 15 MHz for 0.5 cm signals, to 20 MHz for 1 cm signals.

**External:** for signals at least 0.5 V pk-pk; dc coupled, dc to 20 MHz; ac coupled, 10 Hz to 20 MHz; ACF, approx. 2 kHz to 20 MHz; max. input, 600 V pk (dc + ac).

**Line:** triggering from line frequency also selectable.

**Trigger point and slope:** selectable in both normal and automatic; from any point on the vertical waveform presented on crt, or continuously variable from -5 to +5 volts on external sync signal; positive or negative slope.

**Trigger hold-off:** time continuously variable, exceeding one full sweep at 50 msec/cm and faster, prevents multiple triggering on signals that have desired triggering level and slope appearing more than once per cycle.

**Trigger input RC:** dc and ac, approx. 1 megohm shunted by 50 pF; ACF, approx. 120 k ohms shunted by 50 pF.

**Single sweep:** front panel switch permits single sweep operation.

**Horizontal input:**

**Bandwidth:** dc to 500 kHz.

**Deflection factor (sensitivity):** vernier and X10 magnifier permit continuous adjustment from approx. 300 mV/cm to 30 V/cm.

**Input RC:** 1 megohm shunted by approx. 50 pF.

**Weight:** net 5 lbs (2.3 kg); shipping 7 lbs (3.2 kg).

**Price:** HP Model 1423A, \$450.

## TIME BASE, DELAY GENERATOR

Detailed analysis of complex waveforms  
Model 1421A



## OSCILLOSCOPES

The Model 1421A Time Base and Delay Generator provides sweep speeds to 20 nsec/cm with stable triggering to 20 MHz and beyond. Accurately controlled time intervals can also be generated, at the end of which a second sweep in the unit provides the CRT deflection signal. This delayed sweep feature permits detailed examination of any portion of a complex signal or pulse train. The Model 1421A can also trigger the deflection sweep at the end of the delay interval either automatically, internally, or externally. In automatic, the delayed sweep is immediately triggered at the end of the delay interval, permitting accurate measurements of time jitter in the input waveform. In internal and external, the delayed sweep is merely armed at the end of the delay interval and the input signal actually triggers the delayed sweep. Thus the display is free from jitter even though there may be appreciable jitter in the input signal itself, and accurate measurements of rise time or amplitude are possible.

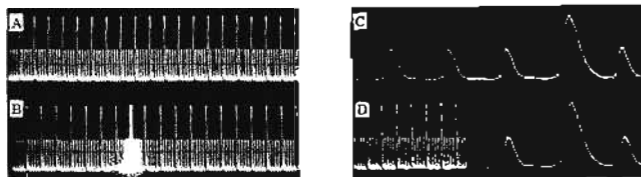
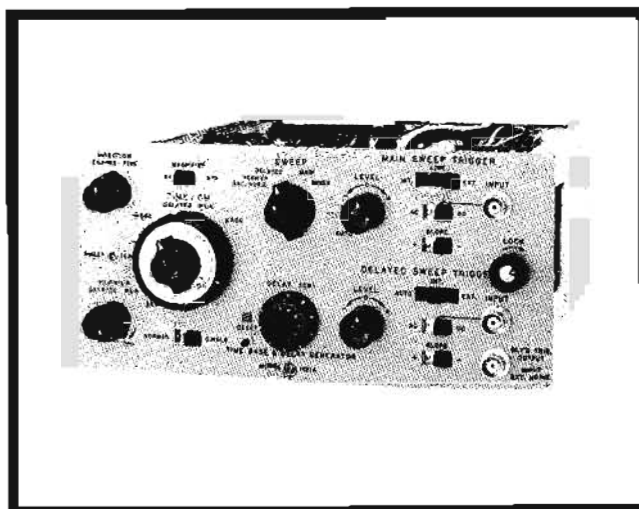

The four basic sweep modes of the Model 1421A are shown above. (A) Normal Sweep; (B) Intensified Sweep, the deflection developed by the delaying sweep and the trace brightened during the time that the delayed sweep is running; (C) Delayed Sweep, the brightened portion of (B) expanded to full screen; and (D) Mixed Sweep, beam deflected initially by delaying sweep and then by the faster delayed sweep.

### Specifications

**Main sweep:** for displaying signals vs time where sweep delay is not required; employs the main time base only.

**Range:** 0.2  $\mu$ sec/cm to 1 sec/cm, 21 ranges in a 1, 2, 5 sequence; accuracy  $\pm 3\%$ ; vernier provides continuous adjustment between steps and extends 1 sec/cm step to at least 2.5 sec/cm.

**Triggering:** (when used with Model 1402A).

#### Amplitude selection

**Internal:** approx 10 Hz to 15 MHz for signals causing 0.5 cm or more vertical deflection, to 20 MHz for 1 cm signals; also from line signal.

**External:** for signals at least 0.5 V pk-pk; dc coupled, dc to 20 MHz; ac coupled, approx. 5 Hz to 20 MHz.

**Trigger point and slope:** controls allow selection of level and positive or negative slope; trigger level of external sync signal is continuously variable from  $-5$  to  $+5$  volts.

**Automatic:** baseline displayed in the absence of an input signal; internally down to 40 Hz on signals causing 1 cm or more vertical deflection, also on line signal; externally down to 40 Hz on signals at least 1 V pk-pk; trigger slope, positive or negative.

**Trace intensification:** used for setting up Delayed or Mixed Sweep modes by increasing brightness of portion of Main Sweep which will be expanded to full screen in Delayed Sweep, or magnified portion of display in Mixed Sweep; rotating Delayed Sweep time switch out of Off position activates intensified mode.

**Delayed sweep:** delayed time base sweeps after a time delay set by Main Sweep and Delay Controls.

**Range:** 0.2  $\mu$ sec/cm to 50 msec/cm, 17 ranges in a 1, 2, 5 sequence; accuracy  $\pm 3\%$ ; vernier provides continuous adjustment between steps and extends 50 msec/cm step to at least 125 msec/cm.

**Delay (before start of delayed sweep)**

**Time:** continuously variable from 0.5  $\mu$ sec to 10 sec.

**Accuracy:**  $\pm 1\%$ ; linearity,  $\pm 0.2\%$ ; time jitter less than 0.005% of max. delay of each range (1 part in 20,000).

**Trigger output:** (at end of delay time) approx. +4 V with less than 150 nsec risetime, from 1 k ohms output impedance.

**Triggering:** (applies to intensified Main, Delayed, and Mixed Sweep modes).

**Automatic:** delayed sweep starts precisely at end of delay period.

**Internal:** delayed sweep triggered by vertical waveform presented on CRT after end of delay period; approx. 10 Hz to 15 MHz for signals causing 0.5 cm or more vertical deflection, or to 20 MHz for 1 cm signals.

**External:** delayed sweep triggered by external signal after end of delay period; for signals at least 0.5 V pk-pk; dc coupled, dc to 20 MHz; ac coupled, approx. 5 Hz to 20 MHz.

**Trigger point and slope:** (internal and external) Same as Main Sweep.

**Mixed sweep:** dual sweep-speed display in which main sweep drives first portion of display, and delayed sweep completes the display at sweep speeds up to 100 times faster; change-over point determined approx. by delay setting.

**Triggering:** same as for Delayed Sweep.

**Magnifier:** X10, any display; overall accuracy  $\pm 5\%$ ; expands 0.2  $\mu$ sec/cm speed to 20 nsec/cm.

**Single sweep:** any display can be operated in single sweep.

**Horizontal input**

**Bandwidth:** dc to typically better than 500 kHz.

**Deflection factor (sensitivity):** vernier and X10 magnifier permit continuous adjustment from approx. 0.3 V/cm to 30 V/cm.

**Input RC:** 1 megohm shunted by less than 20 pF.

**Weight:** net, 5 lbs (2,3 kg); shipping, 7 lbs (3,2 kg).

**Price:** HP Model 1421A, \$625.



## SAMPLING VERTICAL AMPLIFIER

Bandwidths to 12.4 GHz at 1 mV/cm  
Model 1411A

The HP Model 1411A Sampling Vertical Amplifier is a basic vertical plug-in for the Model 140A/141A Oscilloscopes that accepts a series of wide band samplers (see opposite page). All three samplers have 1 mV/cm deflection factor (sensitivity). Feed-through inputs are also featured, for monitoring signals without terminating them and for precise Time Domain Reflectometry measurements. The remote samplers, connected to the oscilloscope by a five-foot cable, can be placed right at the signal source, eliminating line losses.

Risetime is set with a control on the Model 1411A front panel, thereby allowing convenient adjustment of risetime and bandwidth to the ultimate when needed (at the sacrifice of increased noise). Measurement capability of the Model 1411A is enhanced by the front panel recorder outputs, and an X-Y mode for wideband phase measurements.

### Specifications

(When used with Models 1430A, 1431A, 1432A)

**Mode of operation:** (1) Channel A alone, (2) Channel B alone, (3) Channel A and Channel B, dual trace, (4) Channel A plus Channel B, added algebraically, (5) Channel A vs Channel B, X-Y operation.

**Polarity:** any mode, either Channel, negative or positive up.

**Deflection factor (sensitivity):** 1 mV/cm to 200 mV/cm, 8 ranges in a 1, 2, 5 sequence; accuracy  $\pm 3\%$ ; vernier provides continuous adjustment between steps and extends 1 mV/cm step to at least 0.4 mV/cm.

**Isolation between channels:** greater than 40 dB over bandwidth of sampler.

**Recorder outputs:** front panel connectors provide 0.1 V/cm from a 500-ohm source; gain adjustable from approx 0.05 V/cm to 0.2 V/cm; dc level adjustable from approx -1.5 V to +0.5 V.

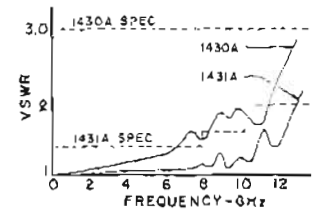
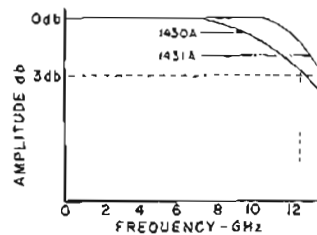
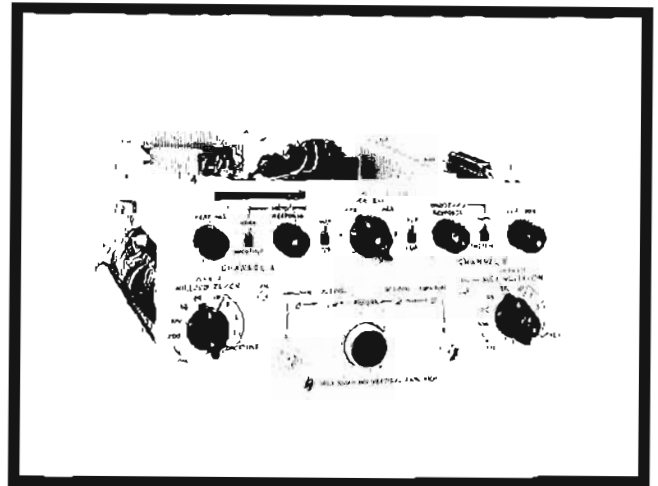

Typical bandwidth (left) and VSWR curves for Models 1430A and 1431A.

Weight: net, 10 lbs (4,5 kg); shipping, 15 lbs (6,8 kg).  
Price: HP Model 1411A, \$700.

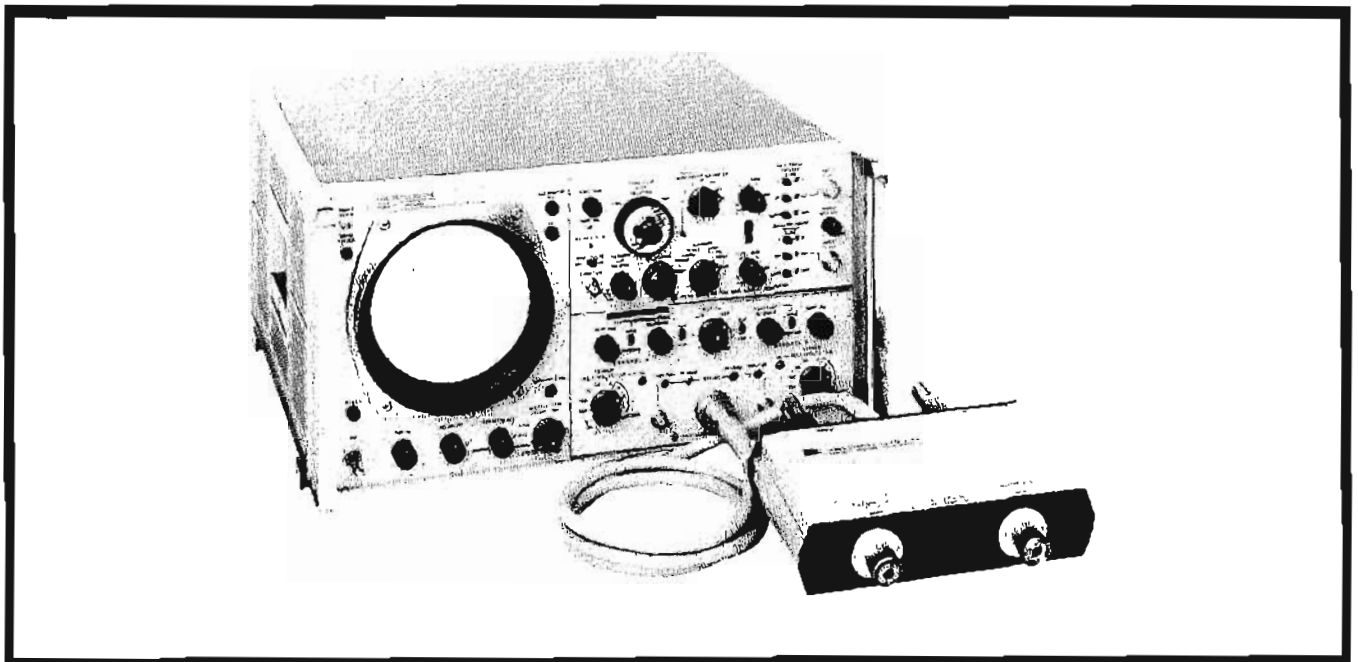

## SAMPLERS

Remote operation, feed-thru inputs  
Models 1430A, 1431A, 1432A



## OSCILLOSCOPES

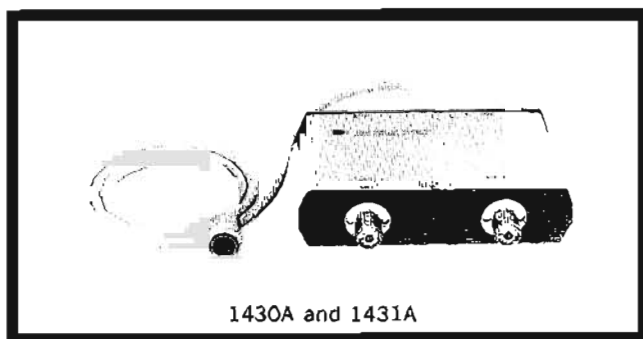

1430A and 1431A

The Model 1430A provides 28 psec risetime with minimum overshoot for accurate measurements on fast-rise signals. Used with the Model 1105A/1106A 20 psec Pulse Generator, its response and feed-through inputs make it ideal for TDR measurements down to a few millimeters resolution.

The Model 1431A allows viewing of sine wave signals from dc to beyond 12.4 GHz at 1 mV/cm sensitivity. It differs slightly from the Model 1430A, having a very flat bandwidth and low VSWR at the sacrifice of increased overshoot. Phase shift measurements can be made to within a few degrees at 5 GHz, as well as accurate VSWR measurements.

The Model 1432A is a lower-priced version of the Models 1430A and 1431A. Its 90 psec risetime, dc to 4 GHz bandwidth, 1 mV/cm sensitivity, and feed-through inputs permit many accurate measurements involving fast pulses, sine waves, and TDR.

### Specifications, Model 1430A (when used with Model 1411A)

**Rise time:** approx. 28 psec (less than 35 psec observed with Model 1105A/1106A Pulse Generator and Model 909A 50-ohm Load).

**Bandwidth:** dc to approx. 12.4 GHz.

**VSWR:** less than 3:1 at 12.4 GHz.

**Overshoot:** less than  $\pm 5\%$ .

**Noise:** (3X rms, or observed signal excluding 10% of random dots) less than 8 mV, 10 mV/cm to 200 mV/cm; noise decreased on automatically smoothed ranges 5, 2, and 1 mV/cm; smoothed position of smoothing switch reduces noise and jitter approx. 4:1; vernier provides continuous adjustment between normal and smoothed modes.

**Dynamic range:**  $\pm 1$  volt.

**Low frequency distortion:** less than  $\pm 3\%$ .

**Maximum input:**  $\pm 3$  volts.

#### Input characteristics

**Mechanical:** precision 7 mm (Amphenol APC-7) connectors on input and output.

**Electrical:** 50-ohm feed-through, dc coupled; reflection from sampler is approx. 10%, using a 40 psec TDR system; pulses emitted from sampler input are approx. 10 mV in amplitude and 5 nsec in duration.

**Time difference between channels:** less than 5 psec.

**Connecting cable length:** 5-ft (for longer cable, see special order below).

**Weight:** net 4 lbs (1.8 kg); shipping 9 lbs (4.1 kg).

**Accessories provided:** two Amphenol APC-7 to female Type N adapters (HP Model 10224A), and two 50-ohm loads (HP Model 909A).

**Price:** HP Model 1430A, \$3000.

**Special order:** 10-ft connecting cable (5-ft is standard), order C01-1430A, add \$35.

### Specifications, Model 1431A (when used with Model 1411A)

**Rise time:** approx. 28 psec.

**Bandwidth:** dc to greater than 12.4 GHz (less than 3 dB down from a 10 cm reference).

**VSWR:** dc to 8 GHz, 1.4:1; 8 to 10 GHz, 1.6:1; 10 to 12.4 GHz, 2.0:1.

**Noise:** less than 7 mV, 10 mV/cm to 200 mV/cm (otherwise same as Model 1430A).

**Dynamic range:**  $\pm 1$  volt.

**Low frequency distortion:** less than  $\pm 3\%$ .

**Maximum input:**  $\pm 3$  volts.

#### Input characteristics

**Mechanical:** precision 7 mm (Amphenol APC-7) connectors on input and output.

**Electrical:** 50-ohm feed-through, dc coupled; reflection from sampler is approx. 5%, using a 40 psec TDR system; pulses emitted from sampler input are approx. 10 mV in amplitude and 5 nsec in duration.

**Phase shift between channels:** less than  $10^\circ$  at 5 GHz, typically less than  $2^\circ$  at 1 GHz.

**Connecting cable length:** 5-ft (for longer cable, see special order below).

**Weight:** net 4 lbs (1.8 kg); shipping 9 lbs (4.1 kg).

**Accessories provided:** two Amphenol APC-7 to female Type N adapters (HP Model 10224A), and two 50-ohm loads (HP Model 909A).

**Price:** HP Model 1431A, \$3000.

**Special order:** 10-ft connecting cable (5-ft is standard), order C01-1431A, add \$35.

### Specifications, Model 1432A (when used with Model 1411A)

**Rise time:** less than 90 psec.

**Bandwidth:** dc to 4 GHz.

**Overshoot:** less than  $\pm 5\%$ .

**Noise:** less than 3 mV, 10 mV/cm to 200 mV/cm (otherwise same as Model 1430A).

**Dynamic range:**  $\pm 1$  volt.

**Low frequency distortion:** less than  $\pm 3\%$ .

**Maximum input:**  $\pm 5$  volts.

#### Input characteristics

**Mechanical:** GR Type 874 connectors on input and output.

**Electrical:** 50-ohm feed-through, dc coupled; reflection from sampler is approx. 15%, using a 90 psec TDR system; pulses emitted from sampler input are approx. 50 mV in amplitude and 10 nsec in duration.

**Time difference between channels:** less than 25 psec.

**Connecting cable length:** 5-ft (for longer cable, see special order below).

**Weight:** net 4 lbs (1.8 kg); shipping 9 lbs (4.1 kg).

**Accessories provided:** two GR Type 874-W50 50-ohm loads.

**Price:** HP Model 1432A, \$1000.

**Special order:** 10-ft connecting cable (5-ft is standard), order C01-1432A, add \$35.

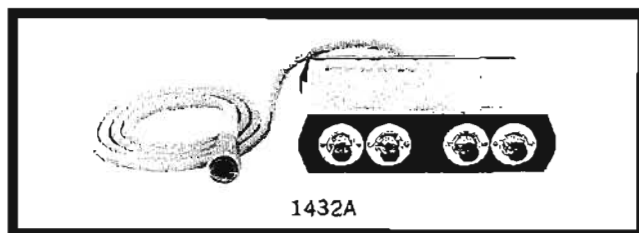

1432A

# OSCILLOSCOPES



## SAMPLING VERTICAL AMPLIFIER

High Z probes; 50  $\Omega$  input; internal triggering  
Model 1410A

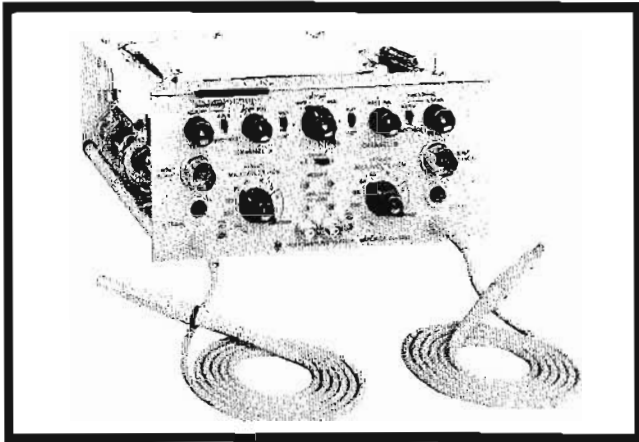

The HP Model 1410A Sampling Vertical Amplifier has the capability of 1 GHz bandwidth at 1 mV/cm sensitivity. The high-impedance probes allow convenient circuit measurements, and the 50-ohm inputs permit direct monitoring of coaxial lines. Both input modes retain the full 1 GHz bandwidth.

Internal delay lines provide convenient triggering when using the 50-ohm inputs. Triggering is selectable from either Channel A or Channel B.

The ability to select the optimum compromise among risetime, overshoot, and noise is available with the front-panel risetime control. The smoothing controls help to further reduce unwanted noise. Also on the front panel, are recorder outputs for driving X-Y or strip-chart recorders.

### Specifications

**Mode of operation:** (1) Channel A alone, (2) Channel B alone, (3) Channel A and Channel B, dual trace, (4) Channel A plus Channel B, added algebraically, (5) Channel A vs Channel B, X-Y operation.

**Polarity:** any mode, either channel, negative or positive up.

**Bandwidth:** dc to 1 GHz.

**Risetime:** less than 350 psec.

**Overshoot:** less than 5%.

**Deflection factor (sensitivity):** 1 mV/cm to 200 mV/cm, 8 ranges in a 1, 2, 5 sequence; accuracy  $\pm 3\%$ ; vernier provides continuous adjustment between steps and extends 1 mV/cm step to at least 0.4 mV/cm.

**Isolation between channels:** greater than 40 dB to 1 GHz.

**Input impedance:**

**Probes:** 100 k ohms shunted by 2 pF, nominal.

**GR type 874 inputs:** 50 ohms  $\pm 2\%$  with 60 nsec internal delay lines for viewing leading edge of fast rise signals; reflection from input connector is approx. 10% using a 150 psec TDR system.

**Noise:** (3X rms, or observed signal excluding 10% of random dots, measured with probe terminated in 50 ohms) less than 1 mV, 5 mV/cm to 200 mV/cm; noise decreased on automatically smoothed ranges 2 and 1 mV/cm; smoothed position of smoothing switch reduces noise and jitter approx. 4:1; vernier provides continuous adjustment between normal and smoothed modes.

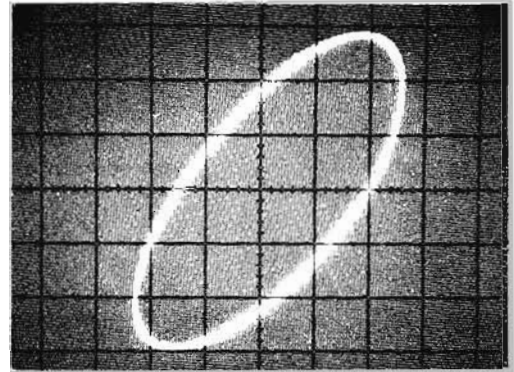

The A vs B mode of the Model 1410A permits X-Y measurements to 1 GHz and above.

**Dynamic range:**  $\pm 2$  volts.

**Drift:** less than 3 mV/hr (after warm-up).

**Maximum input:** probes,  $\pm 50$  volts; 50-ohm inputs,  $\pm 5$  volts.

**Triggering:** internal or external when using 50-ohm inputs; internal triggering selectable from Channels A or B; external triggering necessary when using probes.

**Time difference between channels:** (for probes or 50-ohm inputs) less than 100 psec.

**Recorder outputs:** front panel connectors provide 0.1 V/cm from a 500-ohm source; gain adjustable from approx. 0.05 V/cm to 0.2 V/cm; dc level adjustable from approx.  $-1.5$  V to  $+0.5$  V.

**Accessories provided:**

HP Model	Quantity	Description
10214A	2	10:1 divider
10216A	2	isolator
10218A	2	BNC adapter
10219A	1	GR adapter
10220A	2	Microdot adapter
10221A	1	50-ohm T-connector
10213-62102	6	Ground clip
5020-0457	6	Probe tip
5020-0503	1	Probe adjustment tool
-	1	Accessory box

**Weight:** net, 10 lbs (4,5 kg); shipping, 15 lbs (6,8 kg).

**Price:** HP Model 1410A, \$1600.

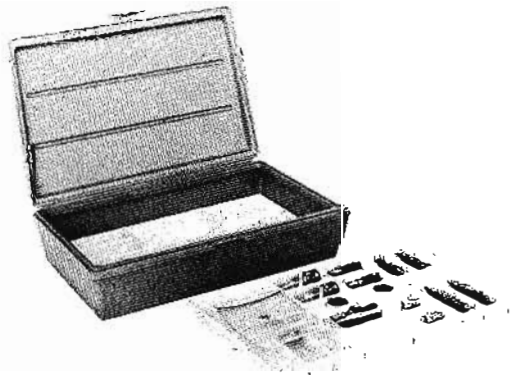

Accessory kit supplied with the Model 1410A



## SAMPLING ACCESSORIES

Probe accessories for the Model 1410 plug-in



## OSCILLOSCOPES

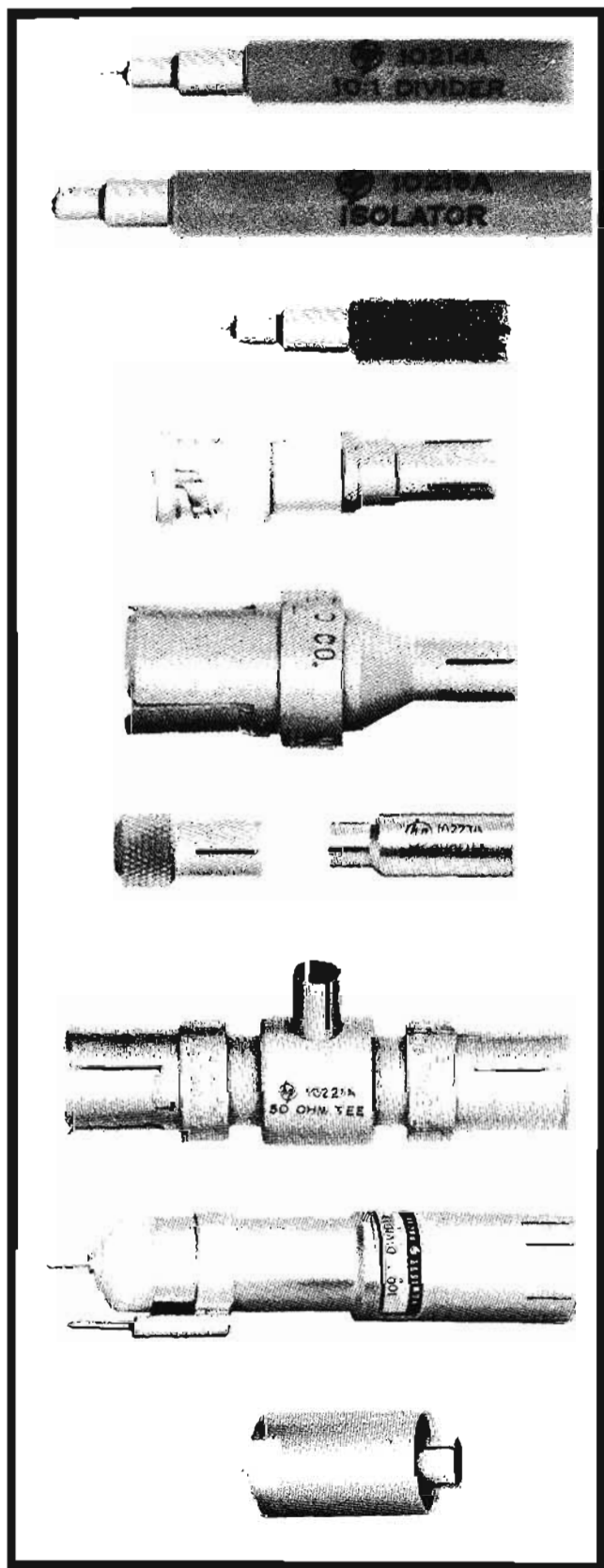

### Model 1410A accessories (separately available) Model 10214A 10:1 divider

Permits accurate measurement of signals as large as 20 volts peak-to-peak and increases the impedance of the Model 1410A probe to 1 megohm shunted by 2.5 pF. The divider fits on the end of the probe so that the probe's small dimensions are preserved. Price, \$30.

### Model 10216A isolator

The isolator increases convenience and accuracy when probing with the Model 1410A by reducing baseline shift and transient response changes caused by changes in the circuit source impedance. The isolator increases the rise time of the Model 1410A to approximately 0.6 nsec, adds no more than 3 pF to the probe input capacity, and retains the high input resistance. Price, \$25.

### Model 10217A blocking capacitor

This blocking capacitor (0.001  $\mu$ F) permits measurements of signals that are  $\pm 50$  volts from ground (to  $\pm 200$  V when used with Model 10214A 10:1 Divider). The blocking capacitor contributes only 1% sag to a 1  $\mu$ sec pulse when used with the Model 1410A probe alone, and 0.1% sag when used with the 10:1 divider. No more than 2.5 pF shunt capacitance is added to the input by the blocking capacitor. Price, \$20.

### Model 10218A BNC adapter

Converts Model 1410A probe tip into a male BNC connector. Price, \$6.

### Model 10219A GR adapter

Converts Model 1410A probe tip into a GR Type 874 connector. Price, \$11.

### Model 10220A microdot screw-on adapter and Model 10223A microdot slide-on adapter

These adapters allow easy connection of the coaxial connectors, and also provide a solid ground reference. Price: HP Model 10220A, \$3.50; HP Model 10223A, \$2.

### Model 10221A 50-ohm T connector

Permits monitoring of signals in 50-ohm transmission lines with the Model 1410A without terminating the line or disturbing the signal. Mismatch is low; the reflection from a step input in a 350-psec rise time system is a 500-psec wide inverted pulse that is no greater than 20% of the input step height. The Model 10221A has two GR Type 874 fittings and will accept a 50-ohm termination when it is desirable to terminate the signal. Price, \$40.

### Available accessories not supplied with Model 1410A Model 10203A 100:1 divider

This 100:1 divider may be used to reduce signal levels as high as 200 V to the  $\pm 2$  dynamic range of the Model 1410A. The Model 10203A offers less than 1 pF shunt capacity and 10 megohms shunt resistance to the circuit under test. (The Model K01-10203A Divider Adapter must be used to adapt the Model 10203A to the Model 1410A probe.) Price, \$40.

### Model K01-10203A divider adapter

Adapts the Model 10203A 100:1 Divider to the Model 1410A probe. Price, \$20.





## SAMPLING TIME BASE

Direct Readout of all Sweeps

Model 1424A

The Model 1424A is an easy-to-use sampling time base plug-in for the 140A/141A Oscilloscopes, and is used with either the Model 1410A or 1411A sampling vertical amplifier plug-ins. The Model 1424A features calibrated sweep speeds as fast as 10 psec/cm, low jitter, triggering to 5 GHz, and direct readout sweep speeds, even when in the expanded mode of operation. An intensified marker identifies the point on the sweep around which the expansion takes place, and a front panel switch allows the operator to quickly switch back and forth between expanded and normal sweep modes, making trace set-up simple and fast. Highly accurate time interval measurements are made possible by the calibrated marker position control.

The single scan feature helps provide clearer photos and stored displays of signals which are changing and/or drifting. The external scan input feature makes the Model 1424A adaptable to various automatic systems, and allows it to be used with a strip chart recorder rather than a more expensive X-Y recorder.

### Specifications

**Range:** 10 psec/cm to 500  $\mu$ sec/cm, 24 ranges in a 1, 2, 5 sequence; 1 nsec/cm to 500  $\mu$ sec/cm sweeps may be expanded up to 100 times and read out directly; 10 psec/cm to 500 psec/cm sweeps are obtained by expansion, and also read out directly; accuracy  $\pm 3\%$ , except for slight non-linearity at start of normal (unexpanded) sweep, and  $\pm 5\%$  on 200  $\mu$ sec/cm and 500  $\mu$ sec/cm; vernier provides continuous adjustment between steps and extends 10 psec/cm step to at least 4 psec/cm.

**Marker position:** intensified marker indicates point about which sweep is expanded; 10-turn calibrated control.

**Minimum delay:** less than 55 nsec.

**Triggering:** (less than 1 GHz)

**Internal:** (with Model 1410A)

**Automatic:** baseline displayed in the absence of an input signal.

**Pulses:** at least 75 mV amplitude required of fast rise pulses 2 nsec or wider for jitter less than 20 psec.

**Sine waves:** signals from 60 Hz to 500 MHz require 25 mV amplitude for jitter less than 10% of input signal period (usable to 1 GHz with increased jitter).

**Level select:**

**Pulses:** at least 50 mV amplitude required of fast rise pulses 2 nsec or wider for jitter less than 20 psec.

**Sine waves:** signals from dc to 300 MHz require 25 mV amplitude (increasing to 200 mV at 1 GHz) for jitter less than 1% of input signal period + 10 psec.

**External**

**Automatic:** baseline displayed in the absence of an input signal.

**Pulses:** at least 100 mV amplitude required of fast rise pulses 2 nsec or wider for jitter less than 20 psec.

**Sine waves:** signals from 60 Hz to 500 MHz require 50 mV amplitude for jitter less than 10% of input signal period (usable to 1 GHz with increased jitter).

**Level select:**

**Pulses:** at least 50 mV amplitude required of fast rise pulses 2 nsec or wider for jitter less than 20 nsec.

**Sine waves:** signals from dc to 1 GHz require 50 mV for jitter less than 1% of input signal period + 10 psec; jitter is less than 50 psec for signals of 10 mV amplitude at 1 GHz.

**Slope:** positive or negative.

**Sensitivity:** jitter specifications given above are for sensitive mode; normal mode reduces sensitivity by approx. 10:1.

**Dynamic range:** (external) 100 mV in sensitive; 1.0 V in normal.

**External trigger input:** 50-ohms, ac or dc coupled; signal output less than 10 mV in sensitive, and less than 5 mV in normal.

**Maximum input:** sensitive, 5 V rms or peak transient; normal, 5 V rms (50 V pk transient); internal, 5 V rms or peak transient.

**Jitter:** less than 10 psec on 1 nsec/cm range and less than 20 psec (or 0.005% of unexpanded sweep, whichever is larger) at 2 nsec/cm and slower, with large amplitude signals having risetimes of 1 nsec or faster.

**Triggering:** (greater than 1 GHz) jitter less than 20 psec for 25 mV input, 500 MHz to 5 GHz.

**Scanning**

**Internal:** X axis driven from internal source; scan density continuously variable.

**Manual:** X axis driven by manual scan control.

**Record:** X axis driven by internal slow ramp; approx. 60 seconds for one scan.

**External:** 0 to +15 V required for scan; input impedance, 10K ohms.

**Single scan:** one scan per actuation; scan density continuously variable.

**Sync pulse output**

**Amplitude:** greater than 1.5 V into 50 ohms.

**Rise time:** approx. 1 nsec.

**Overshoot:** less than 5%.

**Width:** approx. 1  $\mu$ sec.

**Relative jitter:** less than 10 psec.

**Repetition rate:** one pulse per sample.

**Weight:** net 5 lbs (2,3 kg); shipping 9 lbs (4,1 kg).

**Price:** HP Model 1424A, \$1200.

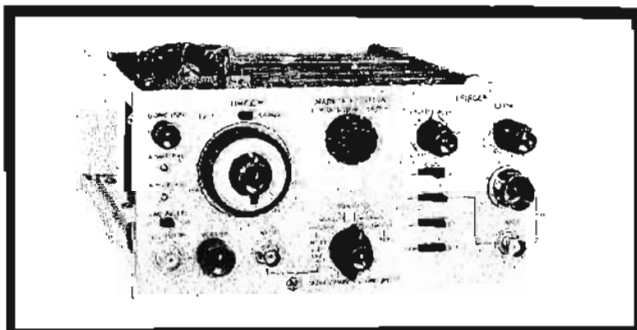

# SAMPLING TIME BASE AND DELAY GENERATOR

Clear displays of long, complex waveforms  
Model 1425A



## OSCILLOSCOPES

The Model 1425A Sampling Time Base and Delay Generator provides calibrated sweep speeds to 10 psec/cm, and sweep delays to 5 msec. The Model 1425A has provision for generating accurately controlled time intervals at the end of which a second sweep provides the time base displayed on the CRT. This delayed sweep feature permits any portion of a complex signal or pulse train to be examined on sweep speeds as fast as 10 psec/cm. In addition, the Model 1425A has two identical trigger circuits which permit the delayed sweep to be triggered at the end of the delay interval, either automatically, internally or externally. In the automatic trigger mode the delayed sweep is immediately triggered at the end of the delay interval, permitting accurate measurements of any rate jitter associated with the input signal. In the level select trigger mode the delayed sweep is armed at the end of the delay interval thereby permitting the input signal to trigger the delayed sweep. Thus, any rate jitter associated with the input signal is effectively eliminated from the display.

Additional magnification of the delayed sweep up to 100 times is provided by a magnifier control. Thus, for example, it is possible to display a pulse train of 100 events and select the 97th event to which the delayed sweep can be synchronized. The 97th event can then be displayed on a time scale thousands of times faster than the former display time. The advantages of the sweep delay technique become apparent when compared to the conventional sweep magnification employed in sampling scopes which allow magnification of only 100 to one and do nothing to eliminate rate jitter.

Automatic triggering facilitates getting a trace on screen by providing a baseline in the absence of an input signal, and triggering without adjustment on most input signals. An intensified marker helps set up magnified traces by identifying the expansion point. A pushbutton return to X1 magnification makes operation even easier by providing a quick look at the unmagnified trace. Simplified front panel controls, including easy-to-use slide switches, also help to simplify operation.

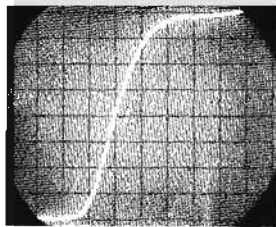
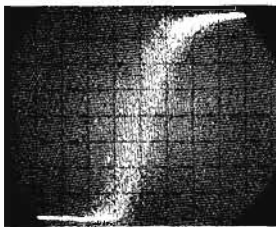

Jitter on delayed pulse in left photo eliminated at right by triggering the delayed sweep. Sweep speed, 1 ns/cm; delay, 5  $\mu$ sec.

### Specifications

#### Main sweep:

**Range:** 1 nsec/cm to 10  $\mu$ sec/cm, 13 ranges in a 1, 2, 5 sequence; accuracy  $\pm 3\%$ , except for slight non-linearity at start of unexpanded sweep; vernier provides continuous adjustment between steps and extends maximum magnified speed to at least 4 psec/cm.

**Magnifier:** X1 to X100 in 7 calibrated steps; increases 1 nsec/cm sweep step to 10 psec/cm; pushbutton returns magnifier to X1.

**Marker position:** intensified marker indicates point about which sweep is expanded; 10-turn control.

**Minimum delay:** Main Sweep, less than 55 nsec; Main Delayed Sweep, less than 105 nsec.

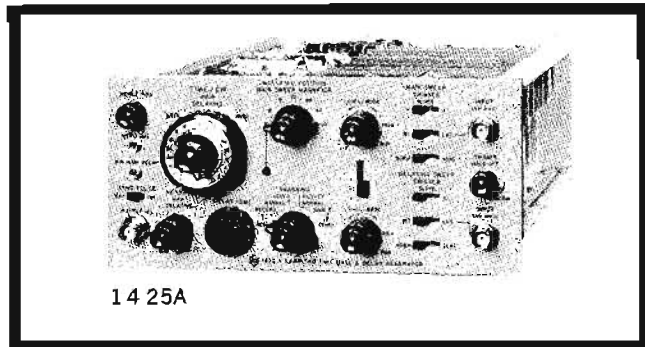

14 25A

#### Triggering: (for both Main and Delaying Sweep)

##### Internal:

**Automatic:** baseline displayed in the absence of an input signal.

**Pulses:** at least 75 mV amplitude required of pulses 2 nsec or wider for jitter less than 30 psec.

**Sine waves:** signals from 200 Hz to 500 MHz require 50 mV amplitude for jitter less than 10% of input signal period (usable to 1 GHz with increased jitter).

##### Level select:

**Pulses:** at least 100 mV amplitude required of fast rise pulses 2 nsec or wider for jitter less than 20 psec.

**Sine waves:** signals from 200 Hz to 300 MHz require 50 mV amplitude (increasing to 400 mV at 1 GHz) for jitter less than 1% of input signal period + 10 psec.

**External:** same as Model 1424A, except low end of sine wave triggering range is 200 Hz.

**Slope:** positive or negative.

**Sensitivity:** jitter specifications given above are for sensitive mode; normal mode reduces sensitivity by approx 10:1.

**Dynamic range:** (external) 100 mV in sensitive; 1.0 V in normal.

**External trigger input:** 50-ohms, ac coupled (2.2  $\mu$ F); signal output, less than 10 mV in sensitive, and less than 5 mV in normal.

**Maximum input:** sensitive, 5 V rms or peak transient; normal 5 V rms (50 V pk transient); internal, 5 V rms or peak transient.

**Jitter:** less than 10 psec on 1 nsec/cm range and less than 20 psec (or 0.005% of unexpanded sweep, whichever is larger) at 2 nsec/cm and slower, with large amplitude signals having rise-times of 1 nsec or faster.

#### Delaying sweep:

**Range:** 10 nsec/cm to 500  $\mu$ sec/cm, 15 ranges in a 1, 2, 5 sequence; accuracy  $\pm 3\%$ , except for slight nonlinearity at start of sweep, and  $\pm 5\%$  on 200  $\mu$ sec/cm and 500  $\mu$ sec/cm; vernier provides continuous adjustment between steps and increases 10 nsec/cm step to at least 4 nsec/cm.

**Delay time:** continuously variable from 50 nsec to 5 msec.

**Accuracy:**  $\pm 3\%$ ; linearity 0.5%; jitter time is less than 1 part in 20,000 or 20 psec, whichever is greater.

**Sweep functions:** main, delaying, and main delayed.

**Scanning:** same as Model 1424A, except no external scan input.

**Sync pulse output:** same as Model 1424A; pulse always synchronized to main sweep trigger circuit; pulse delay and rate are variable.

**Weight:** net, 7 lbs (3.2 kg); shipping, 11 lbs (5 kg).

**Price:** HP Model 1425A, \$1600.

## OSCILLOSCOPES



## SAMPLING ACCESSORIES

Accessory kit, sync probe, and trigger countdowns  
Models 1102B, 10200B, 1103A, 1104A/1106A

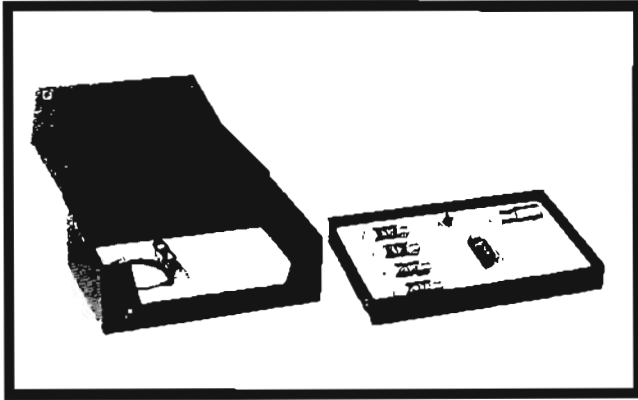

**Model 1102B Accessory Kit**

The Model 1102B Accessory Kit permits convenient circuit probing and reduces circuit loading with oscilloscopes that have 50-ohm input impedances. Thus it allows probing with the Model 1410A where the 50-ohm inputs are used in order to get internal triggering. The kit is also ideal for the Model 1432A where a high input impedance is needed to prevent loading of the test circuit.

Model 10201A to D Resistive Divider Probes. Since the dividers are series resistors, they should always be terminated with 50 ohms to provide the correct voltage division. They should not be attached directly to the Model 1410A probe, which has an input resistance of 100 k ohms. Kit contains one each of the following:

Model	Input Resistance (ohms)*	Division Ratio	Division Ratio with 10205A Sync Take-off	Max Input (vrms)†	μs for 1% Sag with 10209A
10201A	250	5:1	10:1	10	0.25
10201B	500	10:1	20:1	15	0.5
10201C	2500	50:1	100:1	35	2.5
10201D	5000	100:1	200:1	50	5.0

**Model 10200B Sync Probe**



The Model 10200B, for use with Model 1424A and 1425A Sampling Time Bases, increases trigger input impedance to more than 750 ohms, ac coupled. It reduces sensitivity by about 4:1 at 10 MHz and higher, and by about 20:1 at low frequencies. Price, \$50.

**Model 1103A Trigger Countdown**

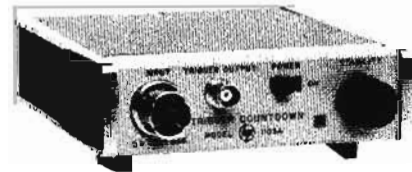

Permits stable triggering, 500 MHz to 10 GHz by dividing down input trigger frequency to about 30 MHz. 15 mV rms input produces less than 30 psec jitter at 5 GHz. Sensitivity decreases above 5 GHz to about 250 mV at 10 GHz. Price, \$325.

**Model 1104A/1106A  
18 GHz Trigger Countdown**



The Model 1104A/1106A counts down signals from 1 GHz to 18 GHz, resulting in an output of about 200 mV at 125 MHz. The unit consists of two parts: the Model 1104A Countdown Supply and the Model 1106A Tunnel Diode Mount.

### Input

**Frequency range:** 1 GHz to 18 GHz.

**Sensitivity:** signals 100 mV or larger, and up to 12.4 GHz produce less than 20 psec of jitter (200 mV required to 18 GHz).

**Maximum safe input:** ±25 mA.

**Input impedance (Model 1106A):** 50-ohm Amphenol APC-7 input connector. Reflection from input connector is less than 10%, using a 40 psec TDR system.

**Signal appearing at input connector:** less than 250 mV step whose top is flat within 2% for 1 nsec.

### Output

**Center frequency:** approximately 125 MHz.

**Amplitude:** typically 200 mV.

### Weight

**Model 1104A:** net 2 lbs (0.9 kg); shipping 4 lbs (1.8 kg).

**Model 1106A:** net 1 lb (0.5 kg); shipping 3 lbs (1.4 kg).

**Price:** HP Model 1104A, \$200; HP Model 1106A, \$550.

# SWEPT FREQUENCY INDICATOR

Speed and simplify swept frequency measurements  
Model 1416A



## OSCILLOSCOPES

The Model 1416A Swept Frequency Indicator transforms the Model 140A/141A into an X-Y oscilloscope which speeds and simplifies microwave swept-frequency measurements. Insertion loss vs. frequency measurements on attenuators, filters, ferrite isolators, and return loss measurements on all types of loads can be made with ease and accuracy.

The Model 1416A incorporates a number of features which provide convenience and accuracy not available with the usually used conventional X-Y scope. Readouts directly in dB are provided by the Model 1416A's logarithmic amplifier. The Attenuation-dB control allows a calibrated dB offset to be applied to an offscreen trace, allowing it to be centered on screen and for high resolution readings. A linear mode of operation is also provided. A chopper stabilized input amplifier minimizes drift, and a front-panel adjustable bandwidth switch allows the operator to select a bandwidth just wide enough to present the signal with a minimum amount of noise. An internal dB calibrator, accurate to 3%, allows a quick check of amplifier accuracy. Also provided on the front panel are outputs for driving an X-Y recorder. Thus, you can now achieve speed, convenience, and accuracy with all types of swept-frequency measurements by using the Model 140A-141A/1416A combination and appropriate auxiliary equipment. Sweep oscillators and associated instruments are available for testing both coaxial and waveguide microwave components from 1 to 40 GHz. Such items as adapters, impedance transformers, tuners, loads, filters, detectors, couplers, and attenuators can be measured or adjusted. Swept-frequency techniques are also useful for over-all system analysis.

Swept-frequency techniques are not only helpful design aids, but can be used as maintenance tools as well. They provide fast routine maintenance checks on laboratory instruments. Hours, and sometimes days, of tedious precise measurements can often be completed within minutes.

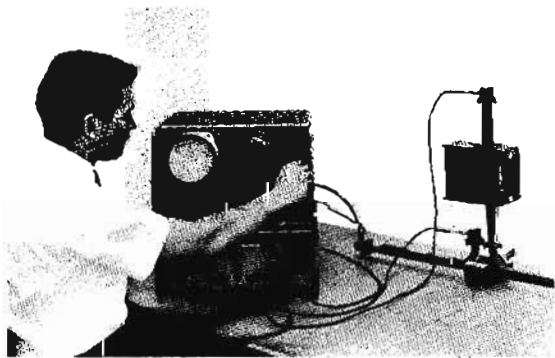

### Specifications

**Mode of operation:** linear or logarithmic.

#### Bandwidth

**Linear:** variable from approximately 1 kHz to 30 kHz in four steps.

**Logarithmic:** varies with input level.

#### Deflection factor (sensitivity)

**Linear:** 50  $\mu\text{V}/\text{cm}$  to 10  $\text{mV}/\text{cm}$ , 8 ranges in a 1, 2, 5 sequence, accuracy  $\pm 3\%$ .

**Logarithmic:** 0.5 dB/cm to 10 dB/cm (referred to rf input into crystal detector) in 5 ranges; accuracy (after 30-min. warmup),  $\pm 0.02$  dB/dB (0 to -25 dB) and  $\pm 0.03$  dB/dB (-25 to -30 dB).

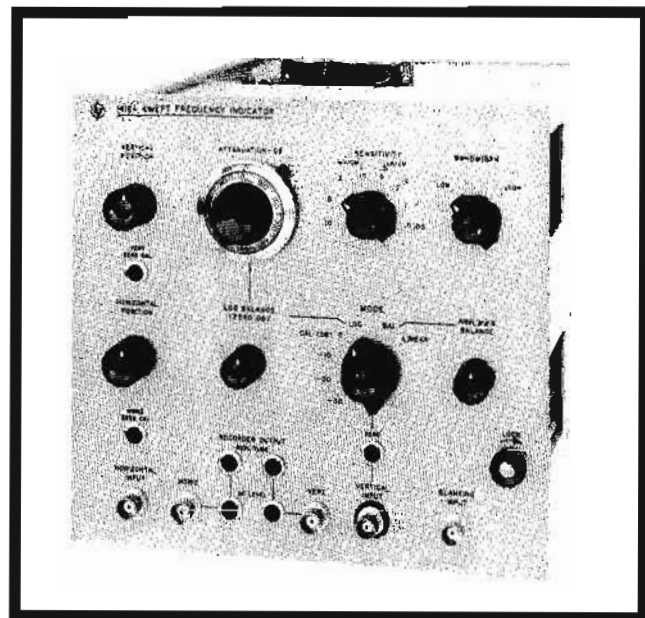

**Noise:** typical observed values on CRT:

Mode	Noise at low bandwidth	Noise at high bandwidth
Linear	40 $\mu\text{V}$ pk-pk	200 $\mu\text{V}$ pk-pk
Logarithmic:		
input signal level		
0 dB	0.05 dB	0.1 dB
-10 dB	0.05 dB	0.2 dB
-20 dB	0.3 dB	0.4 dB
-25 dB	1 dB	1 dB
-30 dB	4 dB	4 dB

**Maximum measured noise at RECORDER OUTPUT:** (measured with a True RMS Voltmeter, and recorder output deflection factor set to 200  $\text{mV}/\text{cm}$ ).

**Linear:** less than 120  $\text{mV}$ ; Model 1416A deflection factor set to 0.05  $\text{mV}/\text{cm}$  and input shorted.

**Logarithmic:** less than 50  $\text{mV}/\text{cm}$ ; Model 1416A deflection factor set to 5 dB/cm and input signal of -50  $\mu\text{V}$  (-30 dB).

**Internal calibrator:** four positions: 0, 10, 20, and 30 dB below approximately 50  $\text{mV}$ ; accuracy  $\pm 0.01$  dB/dB.

**Sweep and blanking:** supplied by Model 690-Series Sweep Oscillator.

#### Recorder outputs

**Vertical:** gain adjustable from 0 to approximately 200  $\text{mV}/\text{cm}$ ; dc level adjustable over approximately  $\pm 1.5$  volts.

**Horizontal:** gain adjustable from 0 to approximately 100  $\text{mV}/\text{cm}$ ; dc level adjustable over approximately  $\pm 1$  volt.

#### Inputs

**Vertical:** input impedance, 75 k ohms; dynamic range: logarithmic, -50  $\mu\text{V}$  to -100  $\text{mV}$ ; linear 0 to -100  $\text{mV}$ ; BNC connector receives output from Models 423A or 424A Crystal Detectors, or Models 786D or 787D Directional Detectors (all Option 02).

**Horizontal:** ramp required: amplitude between 7.5 and 20 volts; some part of ramp must be at 0 volts.

**Blanking:** 0 to -5 V gate (supplied by Model 690-Series Sweep Oscillator; early models require slight modification).

**Power:** supplied by oscilloscope.

**Weight:** net 7 lbs (3.2 kg); shipping 14 lbs (6.3 kg).

**Price:** HP Model 1416A, \$675.



## TIME DOMAIN REFLECTOMETER

### Fast Testing of Cables, Connectors, Striplines

Model 1415A

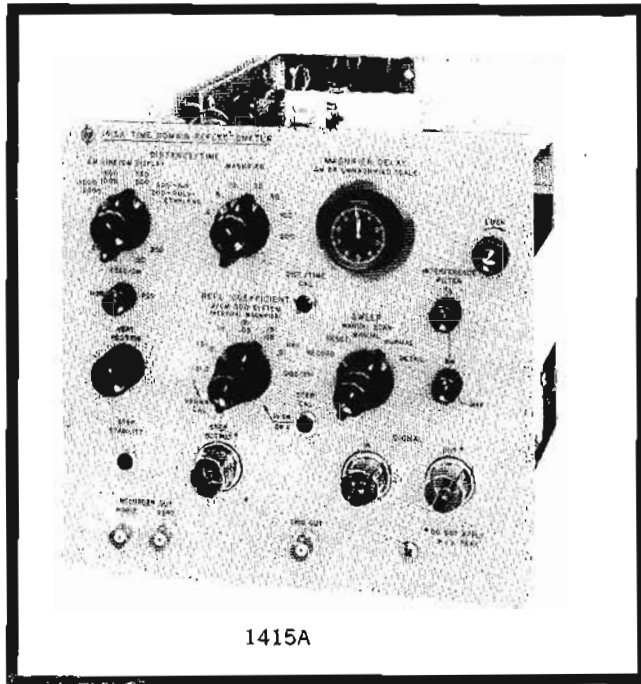

The Model 1415A Time Domain Reflectometer/140A or 141A Oscilloscope represent a completely integrated broadband system for testing cables, transmission lines, striplines, connectors, and many other types of broadband devices. The Model 1415A itself consists of a fast-rise pulse generator, a single-channel sampler, and a time base generator. The method of evaluation is essentially a "closed loop radar"; a voltage step from the pulse generator is fed into the test system and the reflections observed. Reflections occur each time the step encounters an impedance mismatch (i.e., discontinuity) as it travels through the system, and these reflections are added to the incident wave and displayed on the CRT. The time required for the reflection to return to the sampler locates the discontinuity; the shape and magnitude of the reflected wave indicate its nature (i.e., resistive, inductive, or capacitive) and the value of the effective R, L, or C causing the mismatch.

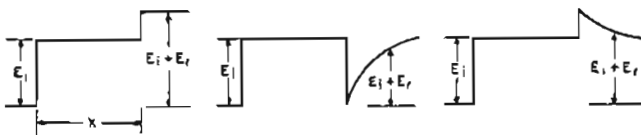

The three displays above represent resistive, capacitive, and inductive discontinuities, respectively. Each discontinuity is located a distance X from the sampling gate, and that distance can be measured directly on the CRT display. From the displays and relationships governing propagation on a transmission line, both qualitative and quantitative information about the system under test is immediately available.

Since discontinuities separated in distance on the line generate reflections separated in time at the monitoring point (input to the Model 1415A), each individual discontinuity is resolved. (The limit on the resolution of two discontinuities depends on the rise time of the pulse generator-oscilloscope system. With Model 1415A, the system rise time is less than 150 psec, allowing a resolution between discontinuities of less than 1 inch.)

The Model 1415A, therefore, measures cable impedances without interference from the mismatch generated at connectors. It also makes it possible to tune antennas for optimum impedance matching, to adjust broadband attenuators for uniform response, and to perform many other measurements with greater resolution and faster than with traditional microwave methods.

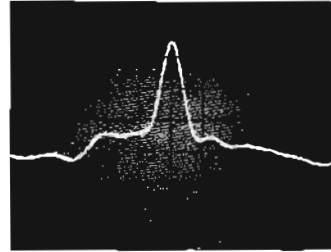

Figure 1. Magnified display of a BNC connector joining two 50-ohm cables. The horizontal axis is set at 2 cm/cm. Multiplying the 3.5 cm deflection by the reflection coefficient sensitivity of 0.01/cm, one can determine the connector has a  $\rho$  of 0.035.

The most conventional method that has been employed to evaluate the quality of a transmission system involves measuring the standing-wave ratio (swr) by feeding a sine wave signal into the line and observing the maximum and minimum amplitudes of the standing waves on the line. A low swr for the overall system is usually desirable. When the system includes several discontinuities, however, the swr measurement does not isolate them; nor does the measurement indicate what must be done to make improvements. It also fails to demonstrate whether or not one discontinuity is generating a reflection of the proper phase and magnitude to cancel the reflection from a second discontinuity, thereby giving a false measure of the actual quality of the system. Pulse reflection testing avoids these inherent disadvantages of the swr technique, since each discontinuity is isolated for analysis. In addition, the measuring system is completely self-contained when using the Model 140A or 141A/1415A, eliminating the cumbersome slotted line-swr meter-signal generator system for broadband transmission.

Features incorporated in the Model 1415A include a "detailed scan" switch which increases the number of samples/cm by a factor of ten. In addition, the Model 1415A includes a trigger output for synchronizing external equipment and a recorder output with manual scan to preserve the trace on a dc x-y recorder. A more extensive description of the applications and measurement techniques of the HP Model 1415A is contained in Application Notes 62, 67, and 75, available on request.



Figure 2. TDR display of a section of unknown cable spliced into a length of 50-ohm cable. Noting the distance setting of 40 cm/cm, and reflection coefficient sensitivity of 0.2/cm, one can determine the unknown cable is 120 cm long and has a  $Z_0$  of 44 ohms. Impedance changes as small as 0.1 ohm are readily resolved when magnified.

## Specifications

### System (in reflectometer configuration)

**Rise time:** less than 150 psec.

**Overshoot:** 5% or less overshoot and ringing (down to 0.5% in 2 nsec).

**Internal reflections:** less than 10% (does not limit resolution).

**Reflectometer sensitivity:** reflection coefficients as small as 0.001 can be observed.

**Rep rate:** 150 kHz nominal.

### Signal channel

**Rise time:** approx. 110 psec.

**Reflection coefficient:** 0.5/cm to 0.005/cm in 1, 2, 5 sequence.

**Input:** 50 ohms, feed-through type.

**Noise and internal pickup, peak:** 0.1% of step (terminated in 50 ohms).

**Dynamic range:**  $\pm 0.5$  volt.

**External signal level:** up to 1 V pk-pk may be safely applied to the SIGNAL OUT connector.

**Attenuator accuracy:**  $\pm 3\%$ .

### Step generator

**Amplitude:** approx. 0.25 V into 50 ohms (0.5 V into open circuit).

**Rise time:** approx. 50 psec.

**Output impedance:** 50 ohms  $\pm 1$  ohm.

**Droop:** less than 1%.

### Distance time scale

**Distance scale (cm line/cm display) accuracy:** 5%.

**Polyethylene line ( $\epsilon = 2.25$ ):** 200 cm/cm to 2000 cm/cm.

**Air line ( $\epsilon = 1$ ):** 300 cm/cm to 3000 cm/cm.

**Time scale:** 20 to 200 nsec/cm,  $\pm 5\%$  accuracy.

**Magnification:** X1 to X200 in 1, 2, 5 sequence.

Accuracy of the basic sweep is maintained at all magnifier settings with the exception of time represented by the first 0.1 cm of the top of the step.

**Delay control:** 0 to 10 cm of unmagnified sweep, calibrated.

**Jitter:** less than 20 psec.

**Power:** supplied by oscilloscope.

**Weight:** net 7 lbs (3.2 kg); shipping 11 lbs (5 kg).

### Accessories furnished

Quantity	Description	HP Part No.
2	GR elbow	1250-0239
1	GR to Type N adapter	1250-0240
1	Type N to BNC adapter	1250-0067

**Price:** HP Model 1415A, \$1050.

**Options:** (specify by option number)

14: Long-line TDR, for polyethylene cables up to 1000 meters (0.62 mile) long; P7 phosphor recommended for Model 140A, no extra charge; specifications same as for standard Model 1415A except as follows:

**System rise time:** less than 200 psec.

**Repetition rate:** 30 kHz, nominal.

**Noise and internal pick-up:** less than 0.25% of step.

**Droop:** less than 2%.

**Time scale:** 20 nsec/cm to 1  $\mu$ sec/cm.

**Air line:** 300 cm/cm to 150 m/cm.

**Polyethylene:** 200 cm/cm to 100 m/cm.

**Price:** HP Model 1415A Option 14, \$1150.

## Time domain reflectometer accessories

### Risetime converters

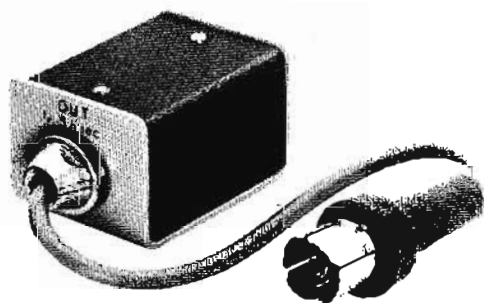

The Model 10452A through 10456A Risetime Converters slow down the step from the Model 1415A in order to eliminate reflections caused by frequencies beyond the bandwidth of interest.

### Specifications

**Rise times:** (10-90% points as measured in 150 psec rise-time system) 10452A, 0.5 nsec; 10453A, 1 nsec; 10454A, 2 nsec; 10455A, 5 nsec; 10456A, 10 nsec.

**Rise time accuracy:** better than  $\pm 5\%$ .

**Overshoot:** less than  $\pm 3\%$ .

**Output impedance (dc):** 50 ohms (accuracy determined by output impedance of generator).

**Output mismatch:** less than  $\pm 5\%$  reflection to output rise time.

**Allowable input voltage:** up to 50 volts, open circuit (from a 50-ohm source).

**Connectors:** GR Type 874.

**Price:** HP Models 10452A through 10456A, \$75 each.

### Calibrated susceptance

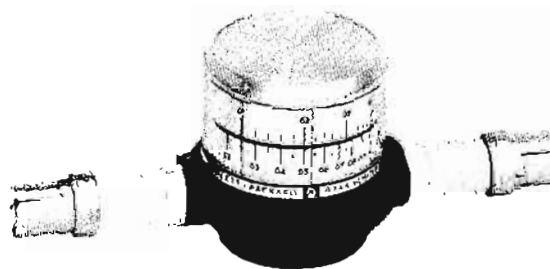

The Model 874A Calibrated Susceptance is a TDR comparison standard for making simple, rapid, and direct-reading evaluations of reactive discontinuities.

### Specifications

**Characteristic impedance:** 50 ohms  $\pm 0.1$  ohm.

**Capacitance range:** 0 to 1 pF.

**Inductance range:** 0 to 2 nH.

**Accuracy:** capacitance:  $\pm 0.005$  pF or  $\pm 5\%$ , whichever is greater, from 0 to 0.5 pF; inductance:  $\pm 0.013$  nH or  $\pm 5\%$ , whichever is greater, from 0 to 1.3 nH.

**Line length:** 17.4 cm.

**Connectors:** GR type 874.

**Price:** HP Model 874A (GR 874 connectors), \$275; 874B (APC-7 connectors), \$325.

## 75-ohm adapters

The 75-ohm adapters convert the Model 1415A 50-ohm GR output connector to 75-ohm systems. CRT overlays for taking direct impedance readings are included.

**Model 10457A:** converts 50-ohm GR connector to 75-ohm Type N; price, \$35.

**Model 10458A:** converts 50-ohm GR connector to 75-ohm Type F (CATV); price, \$25.



10457A



10458A





## PROGRAMMABLE OSCILLOSCOPE

Production line speed; laboratory performance

Model 155A

### Features:

- 5 mV/cm, 25 MHz, 8 cm of vertical display
- Fully programmable
- Pushbutton convenience
- No dc drift
- Calibrated positioning
- Speed up production testing
- Simplify test procedures
- Reduce test time per unit
- Minimize operator errors
- Reduce personnel training time

The HP Model 155A Pushbutton Programmable Oscilloscope embodies all of the advanced features of a high-sensitivity, high-frequency (5 mV/cm, 25 MHz) instrument as well as pushbutton programmability for all of the major scope control functions.

### No dc drift

The unique dc stabilizer in the Model 155A eliminates the troublesome dc drift and shift normally encountered in conventional dc-coupled amplifiers. This feature ensures that the baseline will stay in place indefinitely, thus eliminating errors caused by baseline shift with changes in sensitivity settings, and allows reference levels to be maintained. The trace can be recalled to the same position at any time, which is a time-saving feature when repetitive production units require identical measurements from test to test.

### Calibrated positioning

Due to the elimination of dc drift, calibrated vertical positioning is made possible with a high degree of stability and accuracy. Zero reference can be accurately positioned and maintained over a full 50 cm dynamic range. This assures that even off-screen reference levels can be positioned with confidence. Small signals riding on relatively large dc levels can be easily and precisely observed, maintaining dc coupling throughout the measurement. Pulse characteristic measurements are convenient and accurate. With calibrated offset, dc voltage measurements, normally requiring a voltmeter, can be quickly made with the added convenience of ripple and transient display. The trace can be positioned manually or by programming to  $\pm 5$  cm around the center screen position in 1 cm increments and to  $\pm 25$  cm in 5 cm steps. An illuminated scale indicates the offset selected for accurate reference. A vernier on the front panel allows continuous adjustment between steps.

### Versatile sweeps

Eighteen calibrated sweep settings from 100 nsec/cm to 50 msec/cm can be pushbutton selected. The front panel "X5" magnifier extends the sweep to 20 nsec/cm. Also provided is a manual " $\div 10$ " control which provides slow sweep times to 0.5 sec/cm.

### Pushbutton convenience

Measurements are easier and faster with pushbutton selection of sensitivity and sweep. Ranges can be selected directly without switching through several positions and the selected range pushbutton is illuminated for a positive indication.

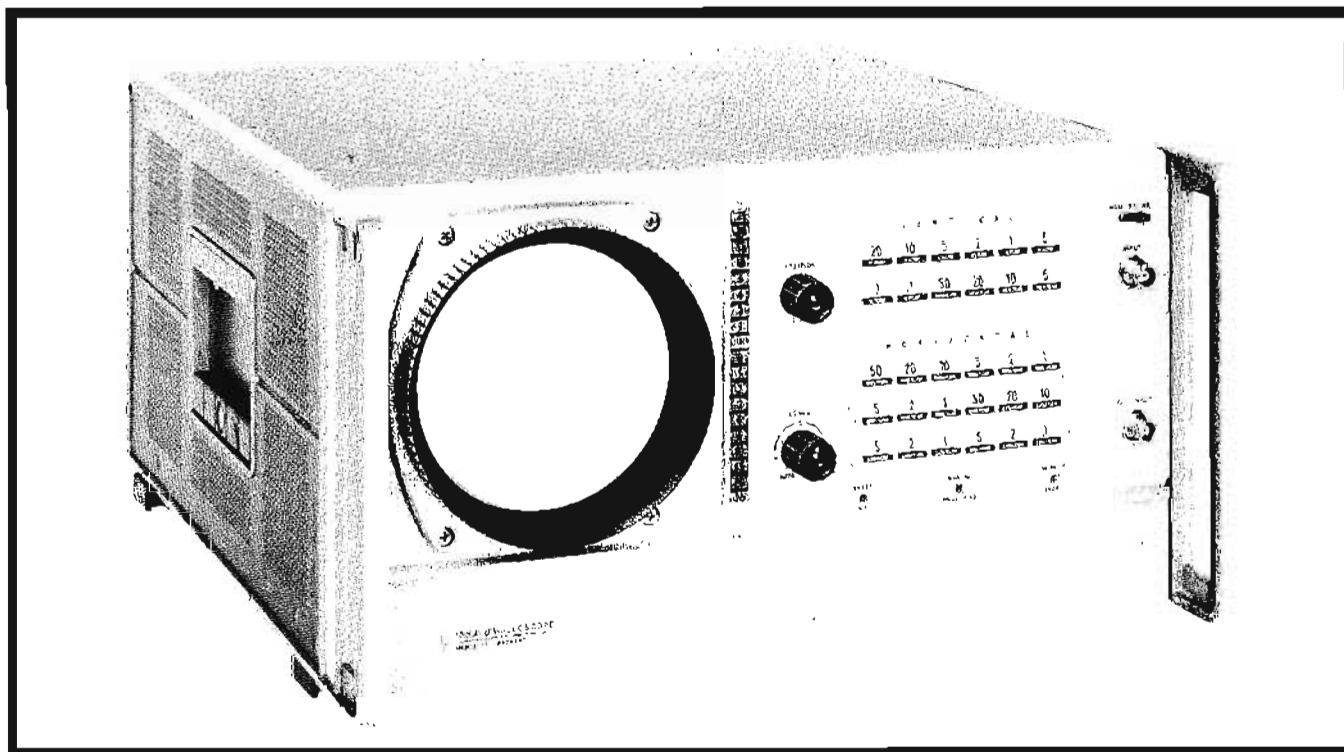



All controls on the Model 155A are readily accessible and logically arranged for convenient operation. The frequently used position, trigger, sensitivity, and sweep controls are located on the front panel. All other necessary controls are available behind the front panel access door. Indicator lights display sensitivity calibration, trigger mode, and sweep magnifier settings.

The rear panel provides an additional vertical signal input connector, intensity modulation terminals and connectors for remote programming, signal output, sweep output, and stabilizer timing output.

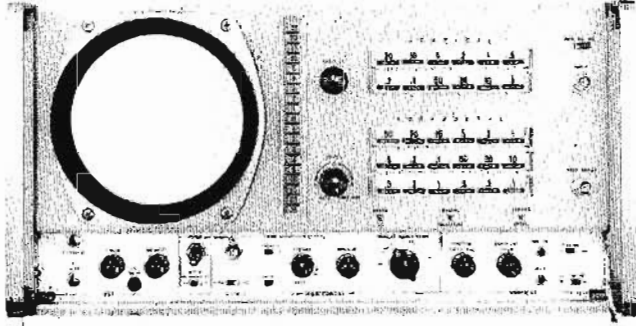

## Programmability

All major functions of the oscilloscope can be programmed with the HP Model 1550A Programmer, or by other external contact-closure-to-ground programmers. These functions include: vertical position, vertical sensitivity, vertical input coupling, sweep times, trigger source, and trigger slope. All programmable functions can be manually overridden individually at any time. The Model 155A Oscilloscope may be ordered without programming circuitry as Option 01. Should programmability be desired at a later date, plug-in circuit boards and required cabling are available to provide this capability.

## Bright, 8 x 10 cm display

The Model 155A utilizes a 7.5 kv post accelerator aluminumized CRT. The CRT provides a full 8 x 10 cm display for easy, error-free observation. The high accelerating potential, combined with aluminumizing produces a sharp bright display for convenient observation even at considerable distances. For added accuracy, the CRT incorporates an internal graticule for parallax-free viewing.

## Modular cabinet

The Model 155A is enclosed in a versatile modular cabinet design which permits quick conversion from bench to rack mounting and convenient accessibility to all components.

## Specifications

### Time base

**Range:** 0.1  $\mu$ sec/cm to 50 msec/cm, 18 ranges in a 1, 2, 5 sequence; accuracy  $\pm 3\%$ , typically  $\pm 1\%$ ; vernier provides continuous adjustment between steps and extends 50 msec/cm step to at least 0.125 sec/cm.

**Magnifier:** X5 sweep expansion may be used on all ranges, and expands the fastest sweep to 20 nsec/cm; accuracy  $\pm 5\%$ , typically  $\pm 3\%$ .

**Slow sweeps:** slows all decade steps of 10, 20, 50 msec/cm speeds to 0.1, 0.2, 0.5 sec/cm respectively; accuracy  $\pm 5\%$ , typically  $\pm 3\%$ .

**Automatic triggering:** (baseline displayed in the absence of an input signal.)

**Internal:** 40 Hz to greater than 25 MHz for signals causing 0.5 cm or more vertical deflection on 50 mV/cm to 20 V/cm steps, and for signals causing 2.0 cm or more vertical deflection on 5 mV/cm to 20 mV/cm steps; also from line voltage.

**External:** 40 Hz to greater than 25 MHz for signals from 0.5 to 10 volts peak-to-peak; input RC, 100 k ohms shunted by approximately 20 pF.

**Trigger slope:** positive or negative slope of external sync signal or internal vertical deflection signal.

### Amplitude selection triggering:

**Internal:** same as automatic internal, except lower cutoff frequency extends to 10 Hz.

**External:** same as automatic external, except lower cutoff frequency extends to 10 Hz.

**Trigger point and slope:** from any point on the vertical waveform presented on crt or continuously variable from  $-5$  to  $+5$  volts on either positive or negative slope of external sync signal.

**Single sweep:** front panel switch and pushbutton-indicator permit single sweep operation.

**Sweep output:** approximately 30 V sawtooth ( $-2$  to

$+28$  V); minimum load RC, 20 k ohms shunted by 150 pF.

### Vertical amplifier

**Bandwidth:** (8 cm reference signal at 1 MHz from a 25-ohm source) dc coupled, dc to greater than 25 MHz at 3 dB down; ac coupled, 2 Hz to greater than 25 MHz at 3 dB down.

**Deflection factor (sensitivity):** 5 mV/cm to 20 V/cm, 12 ranges in a 1, 2, 5 sequence; accuracy  $\pm 2\%$ ; vernier provides continuous adjustment between steps and extends 20 V/cm step to at least 50 V/cm.

**Maximum input:** 400 V peak (dc + ac).

**Input RC:** 1 megohm shunted by approximately 50 pF, constant on all ranges.

**Rise time:** (with a 25-ohm source having a rise time less than 3 nsec) less than 15 nsec at 8 cm reference signal; less than 20 nsec at 25 cm reference signal.

**Position:** baseline may be offset  $\pm 25$  cm from center screen in 1 cm steps from 0 to 5 cm, and 5 cm steps from 5 to 25 cm; accuracy of steps is  $\pm 2\%$  when amplifier gain is calibrated; vernier provides  $\pm 2$  cm adjustment about setting of step offset.

**DC stability:** zero setting dc stabilization maintains a zero offset baseline within  $\pm 0.1$  cm of center screen over entire deflection factor range (after approximately 3-minute warmup); zero setting occurs approximately 3 times per second.

**Signal delay:** signal is delayed so that leading edge of fast rise signals is visible at start of sweep.

**Rear input:** rear panel BNC connector is selected by front panel switch; input RC, 1 megohm shunted by approximately 80 pF; bandwidth, greater than 20 MHz; rise time, less than 18 nsec at 8 cm reference signal.

**Rear output:** rear panel BNC connector provides low-impedance, dc-coupled vertical signal output for an on-screen display; signal is dc stabilized and contains

5 msec switching transients at approximately 3 Hz, with stabilizer operating; with output terminated into 50 ohms: dc level is approximately  $-1.7$  V at center screen; output amplitude is approximately 170 mV/cm; dynamic range is greater than crt graticule display; bandwidth is approximately 25 MHz.

**Stabilizer timing output:** 6-volt pulse ( $-6$  V to 0 V) 5 msec wide, occurs during stabilization; minimum load resistance is 20 k ohms.

#### Remote programming

Programming is accomplished by contact closures to an isolated common line; control lines are at  $-12$  volts and closure current is approximately 20 mA; programmable functions are as follows:

##### Vertical:

**Deflection factor (sensitivity):** 5 mV/cm to 20 V/cm, 12 ranges in a 1, 2, 5 sequence; seven control lines, two used per range.

**Input coupling:** ac or dc; one control line.

**Vertical positioning:**  $\pm 1$  to 5,  $\pm 10$ ,  $\pm 15$ ,  $\pm 20$ ,  $\pm 25$  cm and zero; 12 control lines, two used per range.

##### Time base:

**Range:** 0.1  $\mu$ sec/cm to 50 msec/cm, 18 ranges in a 1, 2, 5 sequence; nine control lines, two used per range.

**Trigger source:** internal, external, or line frequency; three control lines.

**Trigger slope:** positive or negative; two control lines.

**Program inputs:** control lines available at rear panel connector with power for Programmer (Model 1550A) operation.

**Manual operation:** when oscilloscope is remotely programmed, manual function selection is accomplished by selecting the desired range; programming is restored by selecting a new program or resetting the previous program.

### Versatile Programming with the Model 1550A

The HP Model 155A Programmable Oscilloscope and Model 1550A Programmer combination is especially useful in all testing applications where repetitive measurements must be made. Electronic components and circuit assemblies, as well as end items, can be rapidly tested with a programmed Model 155A. Production test procedures are greatly simplified and testing time can be significantly reduced since the oscilloscope is preset and the operator need only push one program button and immediately observe the desired waveform. Repeated adjustments of sensitivity, sweep, etc. are eliminated. Because the procedure is so simple, operator errors and training time are minimized. Because testing can be done faster, fewer test stations and test technicians are required. Not only is the cost per test reduced, but also, oscilloscope control switch maintenance and downtime are significantly decreased. Because of driftless operation and calibrated positioning, the Model 155A can be used as an accurate dc voltmeter, thereby offering the possibility of reducing capital equipment expenditures. DC measurement accuracy is typically within  $\pm 2\%$  of reading and always within  $\pm 4\%$ . The illuminated position, sensitivity and sweep indicators provide quick, easy-to-read verification of the oscilloscope operating modes. To provide testing flexibility, all controls can be operated manually, even when the oscilloscope is programmed. Programmed functions are automatically overridden. Programming is re-established by simply pressing the desired program button.

The speed of complex, automatic checkout systems is no longer limited by the time required to adjust an oscilloscope. Because the Model 155A will not normally have to be adjusted during the test, the operator simply presses one button to obtain

#### General

**Callibrator:** line frequency square wave, 1 volt peak-to-peak, provided through jack on front panel; accuracy is  $\pm 1\%$  ( $+15$  to  $+35^\circ\text{C}$ ), and  $\pm 3\%$  (0 to  $55^\circ\text{C}$ ); rise time, 0.5  $\mu$ sec or less.

**Cathode ray tube:** post-accelerator, 7500-volt accelerating potential; aluminized P2 phosphor (other phosphors available, see modifications); etched safety glass face plate reduces glare.

**Graticule:** 8 cm x 10 cm parallax-free internal graticule marked in cm squares; major horizontal and vertical axes have 2 mm subdivisions.

**Intensity modulation:** approximately +20 volt pulse will blank trace of normal intensity; input terminals on rear panel; dc coupled; input resistance approximately 22 k ohms; rise time less than 60 nsec.

**Dimensions:** 16 $\frac{3}{4}$ " wide, 9" high, 18 $\frac{3}{8}$ " deep overall (426 x 229 x 466 mm); hardware furnished for quick conversion to 8 $\frac{3}{4}$ " x 19" (222 x 483 mm) rack mount.

**Weight:** net, 45 lbs (20 kg); shipping, 55 lbs (24.8 kg).

**Power:** 115 or 230 volts  $\pm 10\%$ , 50 to 60 Hz; approximately 200 W.

**Price:** HP Model 155A, \$2450.

**Modifications:** CRT phosphors (specify by phosphor number); P2 standard; P7, P11, P31 available, no charge.

**Special order:** chassis slides and adapter kit; fixed slides, order HP part No. 1490-0714, \$32.50; pivot slides, order HP part No. 1490-0719, \$37.50; slide adapter kit for mounting slides on scope, order HP part No. 1490-0721, \$20.

**Options:** (specify by option number)

01. Without programming capability, \$2150.

09. With horizontal input in place of sweep output; deflection factor, 200 mV/cm to 2 V/cm; bandwidth, approximately 500 kHz; add \$150.

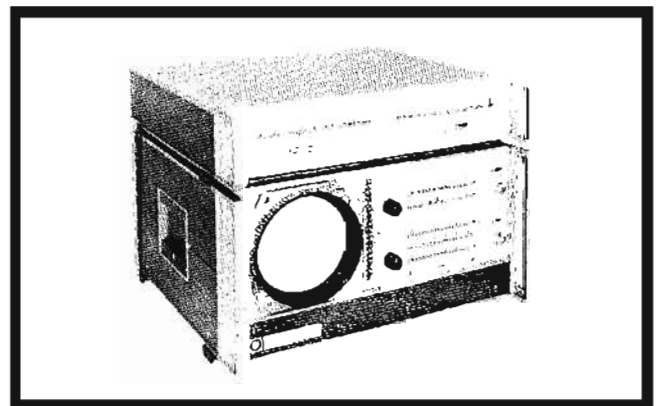

the required test waveform. Bright trace display with no parallax and illuminated function controls permit oscilloscope readings at considerable distances, thereby allowing the system operator to remain at his control console, monitoring the progress of the entire test.

A wide variety of programmers, such as punched or magnetic tape, cards, etc., can also be used to directly program the oscilloscope. If conventional programmers are used alone to directly control the scope, nine contact closures are required to fully activate a program. The Model 1550A, however, uses only one contact closure to select a complete program. The reduction in contact closures is accomplished by the use of a diode programming board.

# OSCILLOSCOPE PROGRAMMER

One pushbutton selects an entire program  
Model 1550A



## OSCILLOSCOPES

### Features

- Programs selectable in any sequence
- Fast, easy program set-up
- Single contact closure selects complete program
- May be cascaded to obtain an unlimited number of programs

The HP Model 1550A Programmer provides a convenient means of presetting test programs for routine repetitive measurements. Insertion of diodes in the program board accomplishes a closure to ground when the selected program relay is activated. A complete series of programs can be set up in minutes by inserting the convenient, easy-to-use diode programming pins into the program board, using the instructions printed directly on the program board.

The Model 1550A Programmer has been specifically designed for use with the Model 155A Oscilloscope and provides a convenient method for presetting the desired test programs. Each Model 1550A Programmer permits selection of up to eighteen programs. Should a greater number be required, the programmers can be cascaded to provide an unlimited number of programs. Illuminated program selection pushbuttons indicate the program in progress.

The Model 1550A Programmer is not limited to use with the Model 155A. By supplying the correct voltages to the Model

1550A, it may be used to program things other than the Model 155A, such as programmable oscillators, power supplies, etc. The versatility of the Model 1550A makes it an ideal instrument for systems use.

The Model 1550A can be used alone to program the oscilloscope or, alternately, can be used as a buffer in a more complex test system. When the Model 1550A is used as a buffer, the main system programmer need supply only one closure to ground to select a complete program.

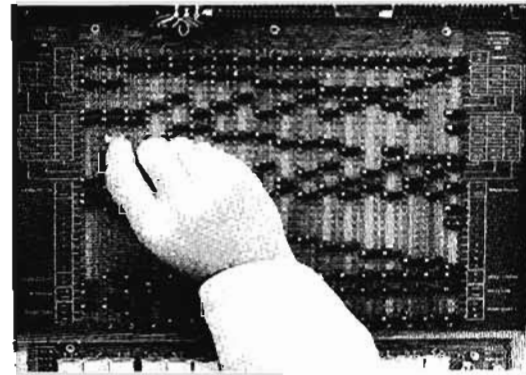

### Specifications

Programmer provides the means for programming vertical sensitivity, vertical positioning, vertical input coupling, sweep time, trigger source, and trigger slope in the Model 155A Programmable Oscilloscope, plus an auxiliary single line function.

**Program storage:** up to 18 different programs may be stored; an additional output connector for the control lines is provided on the rear panel to permit the cascading of programmers if additional program storage is desired.

**Program selection:** a front panel switch permits selection of three operating modes: manual, remote, and off.

**Manual programming:** preset programs are selected in any order by illuminated pushbuttons on the Programmer front panel.

**Remote programming:** programs may be selected externally by making a single contact closure to ground; program control lines are available at a connector on the rear panel; externally selected programs are identified by the illuminated readout on the front panel; external switching must provide break-before-make contact closures; external contacts must switch a maximum of 300 mA.

**Off:** the programmer can be disabled when manual-only operation of the oscilloscope is desired regardless of Programmer switching.

**Programming pins:** programs are preselected by inserting diode pins in a 15" x 10" program board; extra diode pins are included for one auxiliary function per program.

**Power requirements:** power required by the Model 1550A is supplied by the Model 155A Oscilloscope.

**Dimensions:** 16 $\frac{3}{4}$ " wide, 3-15/32" high, 18 $\frac{3}{8}$ " deep overall (426 x 88 x 467 mm); hardware furnished for quick conversion to 3 $\frac{3}{8}$ " x 19" (86 x 483 mm) rack mount.

**Weight:** net 6 lbs (2.7 kg); shipping 12 lbs (5.4 kg).

**Accessories furnished:** Model 10129A Interconnecting Cable to Model 155A Oscilloscope, 3 ft. long; mating connector for remote programming connector.

**Price:** HP Model 1550A, \$600.

**Accessories available:** Model 10130A Interconnecting Cable to Model 155A Oscilloscope, 10 ft. long, \$80; special length interconnecting cables are available upon request.

**Special order:** chassis slides and adapter kit; fixed slides, order HP part No. 1490-0714, \$32.50; pivot slides, order HP part No. 1490-0719, \$37.50; slide adapter kit for mounting slides on scope, order HP part No. 1490-0722, \$15.

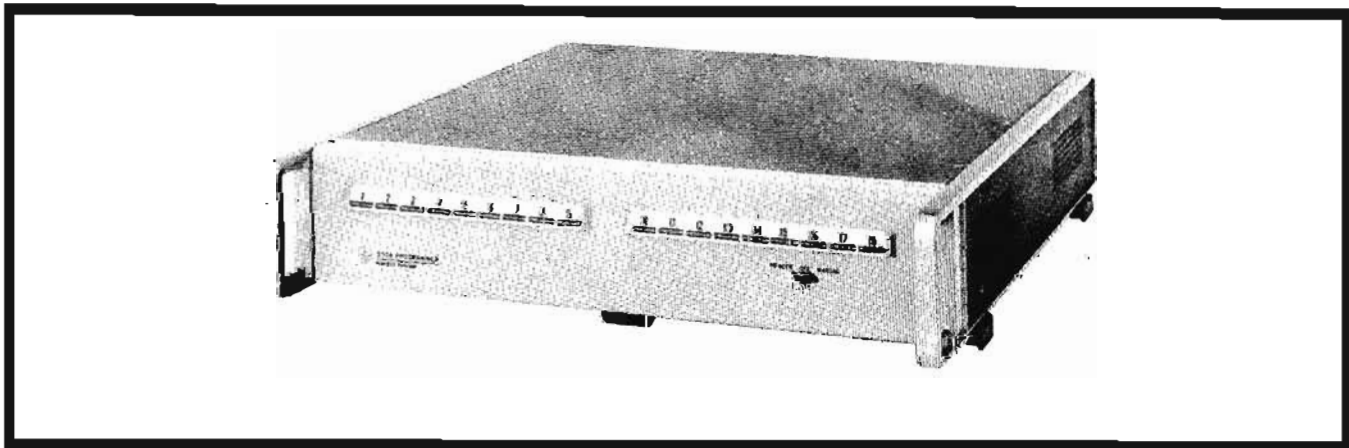



## 50 MHz OSCILLOSCOPE

High-performance scope with versatile plug-ins  
Model 175A

### Features

The HP Model 175A Oscilloscope is an accurate general-purpose test instrument that provides at least 50 MHz of bandwidth for a wide variety of measurements. It has both horizontal and vertical plug-in capability, allowing the user to choose the exact features he desires. Circuitry has been simplified, making it easier to adjust and maintain. In addition, extra features such as the improved triggering, variable hold-off triggering, logically arranged controls and convenient beam finder make the oscilloscope easier to use.

### Horizontal and Vertical Plug-ins

The Model 175A accepts not only a wide line of vertical plug-ins, but also a series of horizontal time axis plug-ins which greatly extend its versatility. Such features as sweep delay, 0.5% time measurements, x-y recorder driving, or pushbutton recordings may be added when needed, allowing one instrument to be used for several widely differing measurements. Four vertical and four horizontal plug-ins are available. In different combinations they adapt the Model 175A to almost any test application.

### Specifications

#### Time base

**Range:** 0.1  $\mu$ sec/cm to 5 sec/cm, 24 ranges in a 1, 2, 5 sequence; accuracy  $\pm 3\%$ ; vernier provides continuous adjustment between steps and extends the 5 sec/cm step to at least 12.5 sec/cm.

**Magnifier:** X1 and X10; overall sweep accuracy within  $\pm 5\%$  in X10.

**Triggering:** internal, ac coupled; power line: external, ac or dc coupled.

#### Triggering sensitivity

**Internal:** approximately 2 mm vertical deflection at 1 MHz, 2 cm at 50 MHz.

**External:** approximately 0.25 V peak to peak at 1 MHz, 0.5 V peak to peak at 50 MHz.

**Triggering point:** controls allow selection of slope and level; external level adjustable from  $-5$  V to  $+5$  V.

#### Horizontal amplifier

**Bandwidth:** dc coupled, dc to 500 kHz; ac coupled, approximately 2 Hz to 500 kHz.

**Deflection factor (sensitivity):** 0.1 V/cm and 1 V/cm; accuracy  $\pm 5\%$ ; vernier provides continuous adjustment between steps and extends 1 V/cm step to at least 10 V/cm.

**Input RC:** 1 megohm shunted by approximately 30 pF.

#### Vertical amplifier

**Rise time:** less than 7 nsec.

#### General

**Calibrator:** 1 kHz square wave, approximately 3  $\mu$ sec rise time; 1 V and 10 V peak to peak; accuracy  $\pm 1\%$  at  $15^\circ\text{C}$  to  $35^\circ\text{C}$ .

**Cathode ray tube:** post accelerator, 12 kV accelerating potential; P31 aluminized phosphor (others available, see modifications); etched safety glass face plate reduces glare.

**Graticule:** 6 x 10 cm parallax-free internal graticule marked in cm squares; major horizontal and vertical axes have 2 mm subdivisions.

**Beam finder:** pressing beam finder control brings trace on crt screen, regardless of setting of horizontal and vertical position controls or intensity controls.

**Intensity modulation:**  $+20$  V pulse will blank trace of normal intensity; BNC connector on rear panel.

**Dimensions:** 16 $\frac{3}{4}$ " wide, 12 $\frac{1}{2}$ " high, 24 $\frac{3}{8}$ " deep overall (425 x 311 x 593 mm); hardware furnished for quick conversion to 12 $\frac{1}{2}$ " x 19" rack mount, 22" deep behind panel (311 x 483 x 559 mm).

**Weight:** net, 64 lbs (29 kg); shipping, 88 lbs (39.5 kg).

**Power:** 115 or 230 volts  $\pm 10\%$ , 50 to 60 Hz, approximately 425 watts (depends on plug-ins).

**Accessories furnished:** two 10:1 voltage divider probes; detachable power cord.

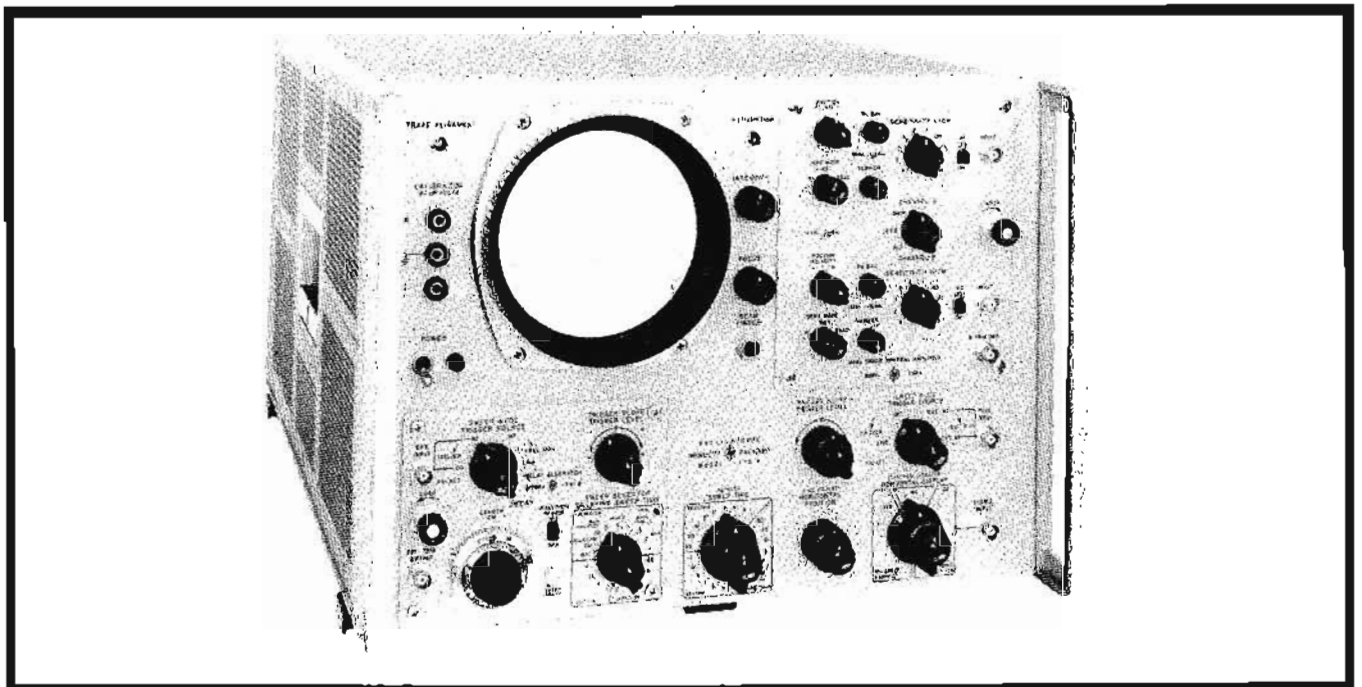

## VERTICAL AMPLIFIERS

Dual channel; high gain differential  
Models 1750B, 1752A



## OSCILLOSCOPES

### Specifications, Model 175A (continued)

**Price:** HP Model 175A, \$1325 (without plug-ins, 2 required).

**Modifications:** CRT phosphors (specify by phosphor number); P31 standard, P2, P7 with amber filter, P11 available, no charge.

**Special order:**

Chassis slides and adapter kit; fixed slides, order HP Part no. 1490-0714, \$32.50; pivot slides, order HP part no. 1490-0720, \$37.50; slide adapter kit for mounting slides on scope, order HP part no. 1490-0721, \$20.

50 to 440 Hz frequency, 115 V or 230 V  $\pm 10\%$  line power, order H12-175A; price \$1375; line filter and modification to meet RFI spec MIL-I-16910A; order H20-175A; price \$1400.

**Options:** (specify by option number).

05. external graticule CRT with P31 phosphor (P2, P7, P11 available, please specify) in lieu of standard internal graticule, add \$25; includes edge-lighting of external graticule.

08. gate and sawtooth outputs, add \$25.

### Model 1750B Dual Trace Vertical Amplifier

Dual 50 MHz channels with simplified triggering at low cost. The 1750B Dual Trace Amplifier permits the user of the 175A Oscilloscope to compare directly two electrical signals with ease and accuracy. Its two independent vertical amplifiers, each with a bandwidth of more than 50 MHz and a maximum sensitivity of 50 mV/cm, can be used either independently or together in five different modes of operation to provide a wide variety of measurements.

For convenience in dual-channel measurements, the Channel B signal can be connected to the Model 175A external trigger input through the use of a trigger amplifier. This feature avoids resorting to an external triggering arrangement for either mode of dual trace presentation.

### Specifications, Model 1750B

**Modes of operation**

**Single channel:** channel A or B.

**Dual channel:** channels A and B displayed on alternate sweeps; channels A and B displayed by switching at 200 kHz rate, trace blanked during switching.

**A + B:** channels A and B added algebraically (single display).

**Vertical amplifier (each channel)**

**Bandwidth:** dc to at least 50 MHz; ac coupled, approximately 2 Hz to 50 MHz.

**Deflection factor (sensitivity):** 0.05 V/cm to 20 V/cm, 9

ranges in a 1, 2, 5 sequence; accuracy  $\pm 3\%$ ; vernier provides continuous adjustment between steps and extends 20 V/cm step to at least 50 V/cm.

**Maximum input:** 600 V dc (ac-coupled input).

**Input RC:** 1 megohm shunted by 23 pF.

**Rise time:** less than 7 nsec.

**Polarity presentation:** + or - up, selectable.

**Differential input:** bandwidth and sensitivity unchanged; common mode rejection at least 30 dB at 0.05 V/cm.

**B trigger output:** B channel signal, amplified, 5 Hz and 2.5 MHz bandwidth, available on front panel.

**General**

**Weight:** net 4 lbs (1,8 kg); shipping 8 lbs (3,6 kg).

**Accessories furnished:** one Model 10121A coaxial cable.

**Price:** HP Model 1750B, \$325.

### Model 1752A High-gain Vertical Amplifier

5 mV/cm sensitivity with differential input. The Model 1752A High-Gain Vertical Amplifier enhances the versatility of the Model 175A Oscilloscope by increasing its sensitivity to 5 mV/cm. The rise time of the Model 175A/1752A combination is less than 20 nsec; this improves to approximately 16 nsec on the less sensitive ranges.

Differential input with at least 40 dB common mode rejection is included for the ranges 5 mV/cm through 50 mV/cm. Isolation between the two input points is at least 80 dB. Substantial feedback in the transistor amplifier stage provides unusually high stability characteristics for a high gain amplifier.

### Specifications, Model 1752A

**Vertical amplifier:**

**Bandwidth:** dc coupled, 50 mV/cm and above, dc to 22 MHz; 20 mV/cm to 5 mV/cm, dc to 18 MHz; ac coupled same as dc coupled except down 3 dB at 2 Hz.

**Deflection factor (sensitivity):** 5 mV/cm to 20 V/cm, 12 ranges in a 1, 2, 5 sequence; accuracy  $\pm 3\%$ ; vernier provides continuous adjustment between steps and extends 20 V/cm step to at least 50 V/cm.

**Input connection:** separate BNC connectors, selectable ac or dc coupling for each; at least 80 dB isolation between inputs; differential input on 5 mV/cm ranges with common mode rejection of at least 40 dB; maximum common mode signal 4 V peak to peak.

**Maximum input:** 600 V dc (ac-coupled input).

**Input RC:** 1 megohm shunted by 35 pF.

**General**

**Weight:** net 4 lbs (1,8 kg); shipping 8 lbs (3,6 kg).

**Price:** HP Model 1752A, \$225.

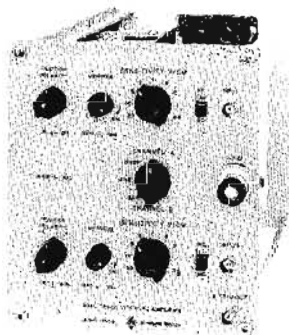

1750 B

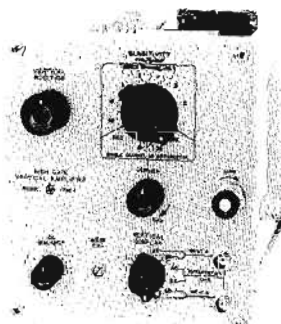

1752A

# OSCILLOSCOPES



## 4 & 2 CHANNEL AMPLIFIERS

4 or 2 trace display,  $\geq 40$  MHz bandwidth

Models 1754A, 1755A

### Model 1754A Four channel amplifier

The Model 1754A provides four 40 MHz channels for logic circuit testing. Trace identifiers and selectable triggering from any channel add to convenience of operation.

#### Specifications, Model 1754A

##### Modes of operation

**Single channel:** any channel (A, B, C, or D) separately:

**Multi-channel:** any combination of channels (2, 3, or 4 displays) on alternate sweeps, or chopped at 1 MHz rate, trace blanked during switching.

##### Vertical amplifier (each channel)

**Bandwidth:** dc-coupled, dc to 40 MHz; ac-coupled 2 Hz to 40 MHz.

**Deflection factor (sensitivity):** 0.05 V/cm to 20 V/cm, 9 ranges in a 1, 2, 5 sequence; accuracy  $\pm 3\%$ ; vernier provides con-

tinuous adjustment between steps and extends 20 V/cm step to at least 50 V/cm.

**Input connection:** separate BNC connectors, selectable ac or dc coupling for each.

**Maximum input:** 600 V dc (ac-coupled input).

**Input RC:** 1 megohm shunted by 22 pF.

**Rise time:** less than 9 nsec.

**Polarity presentation:** + or - up, selectable.

**Trigger output:** single output connector selectable for A, B, C, or D channel input signal, amplifier bandwidth 10 Hz to 8 MHz in alternate mode.

##### General

**Weight:** net, 5 lbs (2.3 kg); shipping, 9 lbs (4.1 kg).

**Accessories furnished:** one Model 10121A Coaxial Cable.

**Price:** HP Model 1754A, \$595.

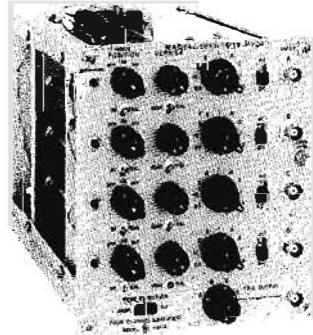

1754A

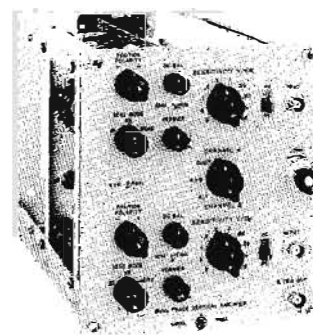

1755A

### Model 1755A Dual trace amplifier

The Model 1755A Dual Trace Amplifier is a versatile two-channel plug-in for measuring both low-level and high-frequency signals. Dual trace displays of transistor circuitry waveforms only a few millivolts in amplitude can easily be observed at frequencies up to 20 MHz with 1 mV/cm sensitivity, or with 10 mV/cm sensitivity at 50 MHz. 500  $\mu$ V/cm sensitivity at 20 MHz can be obtained by applying the same signal to both channels and using the A + B mode, where the Model 1755A combines the signal algebraically.

Time differences between two signals in dual trace displays can easily be measured by use of the trigger amplifier feature. Since the Model 175A is triggered by Channel B alone when the trigger amplifier is connected to the Model 175A external sync input, the time relationship between alternate dual trace sweeps is preserved. Also, syncing on the signal itself rather than on the switching signal in the chopped mode is assured.

#### Specifications, Model 1755A

##### Modes of operation

**Single channel:** channel A or B.

**Dual channel:** channels A and B displayed on alternate sweeps; channels A and B displayed by switching at 200 kHz rate, blanked during switching.

**A + B:** channels A and B added algebraically (single display).

##### Vertical amplifier (each channel)

##### Bandwidth and rise time:

Sensitivity/v	Bandwidth
10 mV/cm to 5 V/cm (sens mode X1)	dc to 50 MHz (8.5 nsec)
5 mV/cm (sens mode X1)	dc to 40 MHz (9 nsec)
1 mV/cm (sens mode X5)	dc to 20 MHz (17 nsec)

**Bandwidth, lower limit:** ac coupled, X1 and X5, 2 Hz; X5 ac, 4 Hz.

##### Deflection factor (sensitivity):

**X1 mode:** 0.005 V/cm to 5 V/cm, 10 ranges in a 1, 2, 5 sequence; accuracy  $\pm 3\%$ ; vernier provides continuous adjustment between steps and extends 5 V/cm step to at least 12.5 V/cm.

**X5 mode:** increases maximum sensitivity to 1 mV/cm; accuracy  $\pm 5\%$ .

**X5 ac mode:** provides internal ac coupling to eliminate drift; sensitivity and accuracy same as X5 mode.

**Maximum input:** 600 V dc (ac-coupled input).

**Input RC:** 1 megohm shunted by 22 pF

**Polarity presentation:** + or - up, selectable.

**Differential input:** common mode rejection at least 20:1, dc to 50 kHz with verniers in Cal; common mode rejection may be increased to greater than 100:1 by adjusting verniers; maximum common mode signal 10 cm display on all sensitivity ranges.

**B trigger output:** B channel signal amplified, 5 Hz to 5 MHz bandwidth; available on front panel.

##### General

**Weight:** net, 5 lbs (2.3 kg); shipping, 9 lbs (4.1 kg).

**Accessories furnished:** one Model 10121A Coaxial Cable.

**Price:** HP Model 1755A, \$575.



## AUXILIARY & SWEEP DELAY

Versatile sweep selection with variable delay  
Models 1780A, 1781B



## OSCILLOSCOPES

### Model 1780A auxiliary plug-in

The Model 1780A Auxiliary Unit allows the Model 175A Oscilloscope to perform all the functions of a standard instrument at minimum cost. Using this plug-in, the full range of the oscilloscope's internal sweeps are available for repetitive sweep operation, and in addition single sweep operation, with either internal arming or arming by an external signal.

### Specifications, Model 1780A

**Sweep occurrence:** normal or single.  
**Sweep arming:** internal or by external pulse, 1 to 200  $\mu$ sec, +15 to 25 V peak.  
**Input connector:** BNC.  
**Weight:** net, 2 lbs (0,9 kg); shipping, 5 lbs (2,3 kg).  
**Price:** HP Model 1780A, \$25.

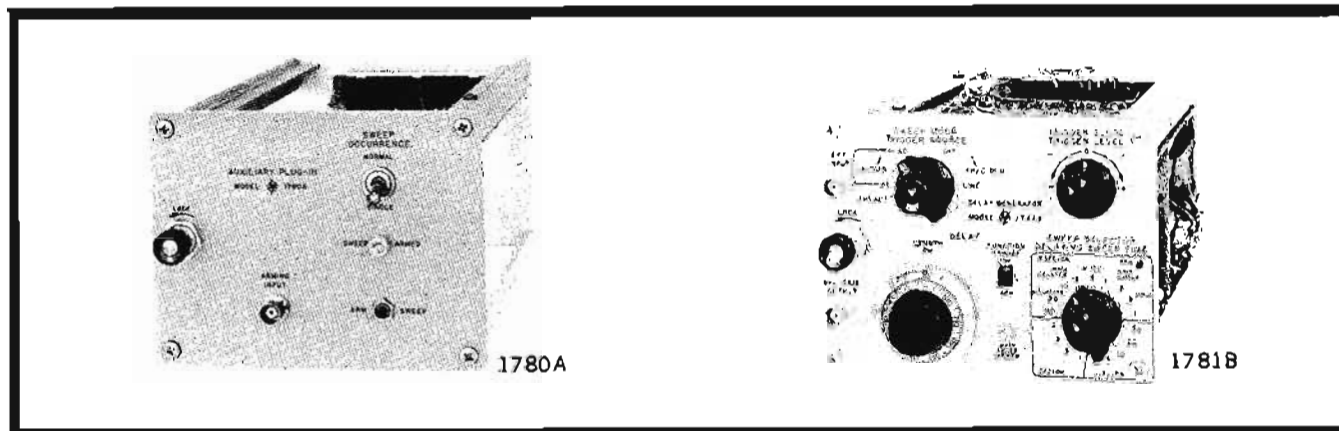

### Model 1781B sweep delay generator

The Model 1781B extends the use of the Model 175A Oscilloscope to exact time delay measurement between reference signal and the point of interest on a complex signal or train of pulses; pulse-to-pulse interval measurement on a pulse train; time-jitter measurement; and, with MIXED SWEEP, simultaneous slow and fast-sweep signal display.

#### Sweep and delay functions

**Main sweep:** this function "locks out" the Model 1781B Delay Generator, allowing the Model 175A to perform as a normal oscilloscope.

**Delaying sweep:** provides fast setup by intensity modulating those pulses to be displayed in Main Delayed Sweep position.

**Main delayed sweep:** two modes of operation are provided.

(1) The start of the scope trace is delayed from the reference signal by an amount determined by the settings of the front-panel delay controls; thus, time jitter between the reference signal and the observed signal can be magnified using a fast main sweep. (2) The Model 175A sweep generator may be armed, but not triggered, at the end of the selected delay interval. The next signal (the signal under observation) triggers the Model 175A sweep. The resulting trace is steady and free from jitter even when jitter is present in the signal being observed. Thus accurate measurements of pulse-to-pulse spacing may be made easily.

**Mixed sweep:** in this function the display is presented using two separate sweep speeds, the slower speed determined by the sweep in the Model 1781B plug-in and the faster speed by the sweep generator in the Model 175A Oscilloscope. The point in time at which the sweep converts from slow sweep to fast sweep is determined by the delay settings on the Model 1781B. In this function it is possible to view simultaneously the character of a pulse train and also "peel off" and expand individual pulses for minute inspection at the end of the train.

**Main single sweep:** a switch on the Model 1781B allows single sweep operation of the Model 175A sweep generator for

displaying transient and other single-shot phenomena. The sweep may be armed either manually with a push button or electrically. A sweep armed light indicates when the sweep is ready to be triggered.

### Specifications, Model 1781B

#### Delay:

**Time:** 0.5  $\mu$ sec to 10 sec delay; delay time is product of delay sweep setting in sec/cm and delay length settings in cm.

**Sweep:** 2  $\mu$ sec/cm to 1 sec/cm; 18 ranges in a 1, 2, 5 sequence.

**Length:** 0 to 10 cm (the physical location, in cm from the beginning of the trace, to the point where the main sweep is triggered).

**Accuracy:**  $\pm 1\%$ , 2  $\mu$ sec to 0.1 sec/cm ranges;  $\pm 3\%$ , 0.2, 0.5, 1 sec ranges;  $\pm 0.2\%$  linearity.

**Function:** trigger main sweep; arm main sweep.

**Jitter:**  $\pm 0.002\%$  maximum delay on each range (1 part in 50,000).

#### Triggering:

**Internal:** ac coupled (2 mm or more vertical display); power line.

**External:** ac or dc coupled (0.5 V peak-to-peak minimum).

**Point:** level and slope selectable; external sync level adjustable  $-5$  to  $+5$  volts.

#### Sweep selection

**Main:** main sweep only.

**Delaying:** brightened segment of trace indicates time relationship between delaying sweep display and main sweep display.

**Main delayed:** main sweep delayed as indicated.

**Mixed:** main and delayed sweeps.

**Single:** single sweep of main.

#### Trigger output:

**Delayed trigger:** approximately +10 volts.

#### General:

**Weight:** net, 4 lbs (2,1 kg); shipping, 7 lbs (3,2 kg).

**Price:** HP Model 1781B, \$325.



# OSCILLOSCOPES



## DISPLAY RECORDER PLUG-INS

Drive for external X-Y & internal strip chart  
Models 1782A, 1784A

### Model 1782A display scanner

Record or digitize CRT displays — used with an x-y recorder, the Model 1782A Display Scanner permits permanent recordings of the waveform displayed on the scope CRT. These high-resolution recordings are not limited by the width or height of the CRT display, but may be as large as the physical size and sensitivity of the recorder will allow.

#### Specifications, 1782A

**Vertical output:** approximately 200 mV/cm; gain and dc level are independently adjustable.  
**Horizontal output:** output level, adjustable to zero volts; output amplitude, adjustable from 0 to  $\pm 15$  volts.  
**Bandwidth:** at least 30 MHz when installed with a 40 MHz vertical plug-in amplifier.  
**Scanning:** manual, internal (with pen speed either stabilized or linear) or external, requires 0 to 15 V for full scan, maximum external scan rate, 1 kHz.  
**Scanning time:** internal, linear: approximately 1.5 minutes; internal, with pen speed stabilized: approximately 20 seconds when displaying time base only.  
**Oscilloscope sweep speed:** from fastest sweep to: 5 msec/cm; signal repetition rate greater than 20 Hz.  
**Remote pen lift:** lifts pen when switching from Record to Arm Recorder.  
**Weight:** net, 4 lbs (1,8 kg); shipping, 6 lbs (2,7 kg).  
**Price:** HP Model 1782A, \$425.

### Model 1784A strip chart recorder

The unique Model 1784A Recorder Plug-in provides an easy, inexpensive way to permanently record displays on the Model 175A Oscilloscope. Simply push a button, and the displayed repetitive waveform is recorded on a strip chart, complete with graticule markings.

Multiple traces can easily be recorded by rewinding the paper as many times as desired. By using the thumb wheel, the starting point of the traces can be made to coincide, thereby preserving time correlation.

#### Specifications, 1784A

**Amplitude recording accuracy:** duplicates CRT display within 3%  $\pm 1$  mm, excluding bandwidth limitation. Bandwidth is dc to greater than 30 MHz when used with a vertical plug-in having 40 MHz or greater bandwidth.  
**Writing rate:** waveforms with slopes of at least 50:1 can be recorded with a continuous line.  
**Line width:** approximately 0.25 mm at normal line intensity.  
**Time recording accuracy:** thumbwheel may be adjusted to provide time correlation between CRT and recording within  $\pm 1$  mm. Linearity of recording within 3%.  
**Repetition rate:** signal rep rates of 60 Hz or greater and sweep speeds of 1 ms/cm and faster are required. (Usable below these limits, but with progressively greater distortion in the form of small steps on the plot.)  
**Recording cycle time:** approximately 30 seconds.  
**Recording paper:** HP Recording Permapaper®; actual recording size 5 x 8½ cm divided into 6 x 10 major divisions, corresponding to the Model 175A graticule markings; one 75-foot roll provides approx. 125 recordings; for single rolls, order HP Part No. 9281-0083; price, \$2.  
 For pack of six rolls, order HP Part No. 9281-0099; price, \$10.  
 For single roll of blue grid paper suitable for photographing, order HP Part No. 9281-0380; price, \$3.  
 For single rolls of translucent paper suitable for making Ozalid reproductions, order HP Part No. 9281-0304; price, \$4.50.  
**Weight:** net, 9 lbs (4,1 kg); shipping, 16 lbs (7,2 kg).  
**Accessories furnished:** six rolls of HP Recording Permapaper.  
**Price:** HP Model 1784A, \$875.



### Model 175A service accessories

#### Vertical Test Adapter

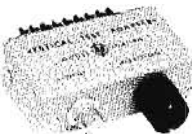

The Model 10404A Vertical Test Adapter provides a convenient means of applying a known voltage to the main vertical amplifier of the Model 175A for setting the gain; price, \$15.

#### Vertical Response Tester



The Model 10405A Vertical Response Tester provides a fast step function for use in establishing and adjusting the "step" response of the main vertical amplifier in the Model 175A. This plug-in generates a positive or negative 2 V adjustable pulse with a rise time less than 1 nsec, 250 pulse rep rate; price, \$125.

#### Plug-in Extenders



The Model 10400B, 30-inch extension cable for Model 175A vertical plug-ins; price, \$25. The Model 10402A, 24-inch extension cable for Model 175A time axis plug-ins; price, \$35.

#### Alignment Attenuator

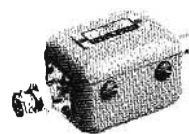

The Model 10403A Alignment Attenuator may be used to check and adjust the input capacity of the Vertical Amplifiers. It is factory set for approx 22 pF input impedance (Models 1754A and 1755A); adjustable for other vertical amplifiers, price, \$35.

## ACCESSORIES—PROBES

Versatile Line of Probes For All Applications



## OSCILLOSCOPES

### Current probe and amplifier

With the HP Model 1110A and Model 1111A Current Probe and Amplifier you can observe fast-rise, ac current waveforms on any wideband oscilloscope. The Model 1110A Probe may be used by itself, giving a sensitivity of 1 mV/mA. The Model 1111A Amplifier increases the 1110A Probe's sensitivity and extends low frequency response. When used with a 50 mV/cm sensitivity oscilloscope, the Model 1111A's attenuator indicates directly in milliamperes per centimeter on the CRT, thus eliminating cumbersome conversion factors.

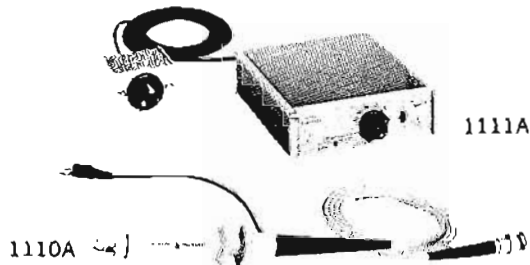

### Specifications, Model 1110A

**Sensitivity:** 1 mV/mA.

**Accuracy:**  $\pm 3\%$ .

**Bandwidth:** lower limit: 1700 Hz (850 Hz with Model 10100B 100-ohm termination); upper limit: inversely proportional to capacitance of load: 4 pF load, 45 MHz, 7 nsec rise time (e.g., Model 140A/1410A/1424A Sampling Oscilloscope); 30 pF load: 35 MHz, 9 nsec rise time (e.g., Model 180A/1801A/1820A Oscilloscope).

**Maximum dc current:** 0.5 ampere.

**Maximum ac current:** 15 amperes pk-pk above 4 kHz; decreasing below 4 kHz at the rate of 3.8 amps/kHz (30 amps pk-pk max. with Model 10100B 100-ohm termination).

**Insertion impedance:** approximately 0.01 ohm, shunted by 1  $\mu$ H; capacitance to ground is less than 3 pF.

**Accessory available:** Model 10100B 100-ohm feed-through termination; decreases sensitivity to 0.5 mV/mA, lower cut-off to 850 Hz; increases maximum ac current to 30 amps pk-pk above 4 kHz; price, \$17.

### Model 1110A with Model 1111A

**Sensitivity:** 1 mA/cm to 50 mA/cm in X1, and 100 mA/cm to 5 amps/cm in X100 (1, 2, 5 sequence) when used with an oscilloscope at 50 mV/cm sensitivity.

**Accuracy:**  $\pm 3\%$  on 50 mA/cm sensitivity and below;  $\pm 4\%$  on 100 mA/cm sensitivity and above, (when Models 1110A and 1111A are calibrated together).

**Bandwidth:** 50 Hz to 20 MHz (18 nsec rise time).

**Noise:** less than 100  $\mu$ A pk-pk, referred to input.

**Maximum ac current:** 50 amps pk-pk above 700 Hz decreasing below 700 Hz at the rate of 1.4 amps/20 Hz.

**Output impedance:** 50 ohms.

### General

**Dimensions:** amplifier: 1½" high, 5½" wide, 6" deep (38 x 130 x 150 mm); probe: aperture, 5/32" (4 mm) diameter; 5 ft. cable (1520 mm).

**Weight:** Model 1110A: net ½ lb (0.23 kg); shipping 1 lb (0.45 kg); Model 1111A: net 2 lbs (0.9 kg); shipping 3 lbs (1.4 kg).

**Power:** 115 or 230 volts  $\pm 10\%$ , 50 to 1000 Hz, approximately 1.5 watts.

**Price:** HP Model 1110A, \$100; HP Model 1111A, \$160.

### Voltage divider probes



10001A

HP Probe	Atton.	Bandwidth (0.5 dB)/MHz	Resist-ance (meg-ohms)	Capaci-tance	Div. accu-racy	Peak input volts	Approx. overall length ft. (cm)	Approx. rise time
10001A or C*	10:1	dc to 30	10	10 pF	2%	600	5 (152)	5 nsec
10001B or D*	10:1	dc to 30	10	20 pF	2%	600	10 (305)	5 nsec
10002A or C*	50:1	dc to 30	9	2.5 pF	3%	1000	5 (152)	5 nsec
10002B or D*	50:1	dc to 30	9	5 pF	3%	1000	10 (305)	5 nsec
10003A or B*	10:1	dc to 40	10	10 pF	2%	600	4 (122)	3 nsec

\*These probes have black identification boots; the others have red boots.

The high impedance input of these probes reduces loading of oscilloscopes on the circuit under test, and the probes provide attenuation for large signals. The probes may be quickly and accurately compensated for optimum step response; price, \$30 each.

### Voltage divider probe tips



10010C

10035A

The Model 10035A Probe Kit and the Model 10010C BNC Tip provide maximum versatility when used with the voltage divider probe. The kit contains a pincer jaw, banana tip, pin tip, hook tip and spring tip; price: Probe Kit, \$5; BNC Tip, \$10.

### Straight-through voltage probe



10025A

The HP Model 10025A is a thin, flexible probe with small, pushbutton pincer jaws which provides a straight-through connection to voltmeters, ohmmeters and oscilloscopes. Maximum input voltage is 600 volts peak, and the shunt capacity is approximately 150 picofarads. The cable is terminated in a shielded dual banana plug; price, \$9.

**OSCILLOSCOPES**



**50 MHz OSCILLOSCOPE**  
 8 x 10 cm display, solid-state, 30 pounds  
 Models 180A, 180AR

**Big picture display, plug-in versatility**  
**Field, laboratory, production applications**



## Bench and rack mount models, plug-in versatility

### Rectangular 8 x 10 cm CRT

Accurate measurements are easier to read... easier to make on the new HP Model 180A *Big-Picture* Oscilloscope. New Hewlett-Packard design breakthrough offers a compact 17-in. long CRT with display area 30% to 100% greater than any other high-frequency scope! You get sharp, crisp traces for resolution of waveform details. The black internal graticule, calibrated in centimeters, and bright trace make measurements easier to read, more accurate. Parallax error is eliminated. The 12 kV accelerating potential produces bright, easy-to-see traces, even at 5 nsec/cm sweeps. Flood guns in the CRT allow variable background illumination for optimum contrast of graticule and trace for excellent photographic recording.

### Solid-state circuitry

Mainframe and plug-ins of the HP Model 180A are all solid-state. Mainframe is the first with power supplies specifically designed for solid-state circuitry — gives you full perfor-

mance benefits from solid-state devices in all present and future plug-ins.

The dual channel 50 MHz at 5 mV/cm vertical amplifiers have low-drift FET input stages for accurate dc measurement — plus quick 15-second warm-up. Vertical plug-ins drive the CRT vertical deflection plates directly, requiring only 3 V/cm. This allows even greater extended bandwidth capabilities in future plug-ins.

### Time base flexibility

Time base plug-ins offer new easy-to-use delayed sweep for examining complex waveforms in detail. Tunnel diode triggering circuits lock-in waveforms to beyond 90 MHz. Exclusive Hewlett-Packard mixed sweep feature combines display of first portion of trace at normal sweep speeds, and simultaneously expands trailing portion of trace at faster delayed sweep speed to allow magnified examination.

New horizontal amplifier has wide bandwidth with X10 magnification to provide linear 5 nsec/cm sweeps, giving you greater resolution of high frequency signals and fast pulses.

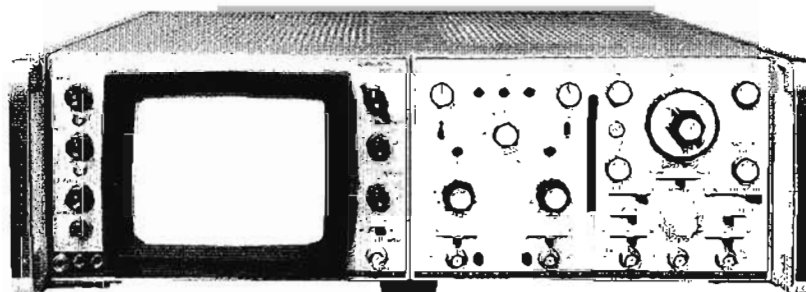

5 1/4-inch Rack Model 180AR for Console Use

## Specifications

### Horizontal amplifier:

#### External input:

**Bandwidth:** dc coupled, dc to 5 MHz; ac coupled, 5 Hz to 5 MHz.

**Deflection factor (sensitivity):** 1 V/cm, X1; 0.2 V/cm, X5; 0.1 V/cm, X10; vernier provides continuous adjustment between ranges; dynamic range  $\pm 5$  V.

**Maximum input:** 600 V dc (ac-coupled input).

**Input RC:** 1 megohm shunted by approximately 30 pF.

**Sweep magnifier:** X1, X5, X10; magnified sweep accuracy  $\pm 5\%$ .

### Calibrator:

**Type:** approx 1 kHz square wave, 3  $\mu$ sec rise time.

**Voltage:** 2 outputs, 250 mV and 10 V p-p.  $\pm 1\%$ .

### General:

**Cathode ray tube:** post-accelerator, 12 kV accelerating potential; aluminized P31 phosphor (other phosphors available; see modifications) with etched safety glass face plate to reduce glare.

**Writing rate:** (using HP Model 197A Camera with f/1.9 lens and Polaroid® 3000 speed film) P31 phosphor approx 700 cm/ $\mu$ sec.

**Graticule:** 8 x 10 cm parallax-free internal graticule marked in cm squares, 2 mm subdivisions on major axes; front panel recessed Trace Align aligns trace with graticule; internal Y-align aligns Y-trace with X-trace; Scale control illuminates CRT phosphor for viewing with hood or taking photographs.

**Beam finder:** pressing beam finder control brings trace on

CRT screen regardless of setting of horizontal, vertical or intensity controls.

**Intensity modulation:** approx +2 V, dc to 15 MHz, will blank trace of normal intensity; input R, 5.1 k ohms; input connector on rear panel.

**Active components:** all solid-state (except CRT).

**Environmental:** Model 180A scope with plug-ins operates within specs over the following ranges: temperature,  $-28$  to  $65^\circ\text{C}$ ; humidity, to 95% relative humidity to  $40^\circ\text{C}$ ; altitude, to 15,000 ft.; vibration, vibrated in three planes for 15 min each with 0.010" excursion from 10 to 55 Hz.

**Power:** 115 or 230 V,  $\pm 10\%$ , 50 to 1000 Hz, 95 watts at normal line, convection cooled.

**Dimensions:** cabinet: 8" wide, 11" high, 22 1/2" deep overall (204 x 280 x 572 cm); rack mount: 19" wide, 5 1/4" high, 19 1/2" deep behind front panel, 21 1/2" deep overall.

**Weight:** (without plug-ins) Model 180A: net 22 lbs (9,9 kg); shipping, 30 lbs (13,5 kg); Model 180AR (rack): net, 25 lbs (11,3 kg); shipping, 33 lbs (14,9 kg).

**Outputs:** four emitter follower outputs for main and delayed gates, main and delayed sweeps; maximum current available,  $\pm 3$  mA; outputs will drive impedances down to 1k $\Omega$  without distortion.

**Accessories furnished:** two Model 1000-4A 10:1 voltage divider probes, mesh contrast filter, detachable power cord, rack mounting hardware (rack only).

**Price:** (without plug-ins) HP Model 180A, \$825; HP Model 180AR (rack), \$900.

**Modifications:** CRT phosphor (specify by phosphor number): P31 standard; P2, P7, P11 available, no extra charge.

**OSCILLOSCOPES**
**50 MHz OSCILLOSCOPE** *continued*  
 8 x 10 cm display, solid-state, 30 pounds  
 Models 180A, 180AR
**Features:**

- Aircraft-type frame construction for maximum ruggedness with minimum weight
- Withstands shock and vibration — built for portable use
- Scope with plug-ins weighs only 30 pounds
- Easy to get at circuits, snap-off covers
- Conveniently-grouped controls are easier to see, easier to operate
- Operates with confidence at  $-28^{\circ}\text{C}$  to  $+65^{\circ}\text{C}$ ; 95% relative humidity to  $40^{\circ}\text{C}$ ; 15,000 feet
- Feet on bottom and back sides for bench (horizontal) or floor (vertical) use
- 8" x 10" cabinet, and  $5\frac{1}{4}$ " x 19" rack models
- 95 watts dissipation, convection cooling, no fan

**Unique plug-ins lock together for optimum performance**

Vertical (left) and time base (right) plug-ins are locked together and installed in the Model 180A/AR as a single

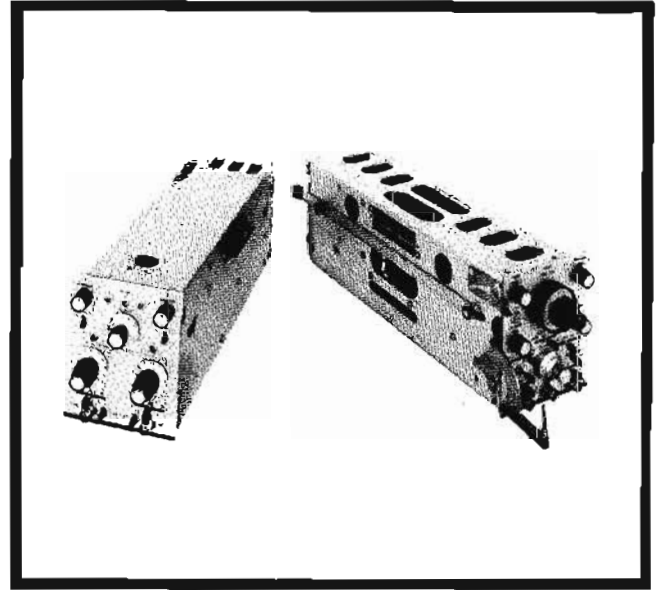

unit. A lever type lock used to secure the plug-ins in the main frame also serves as a handle for removing and carrying the plug-ins. Mating the plug-ins together and using a single main-frame jack reduces lead length and improves overall performance.

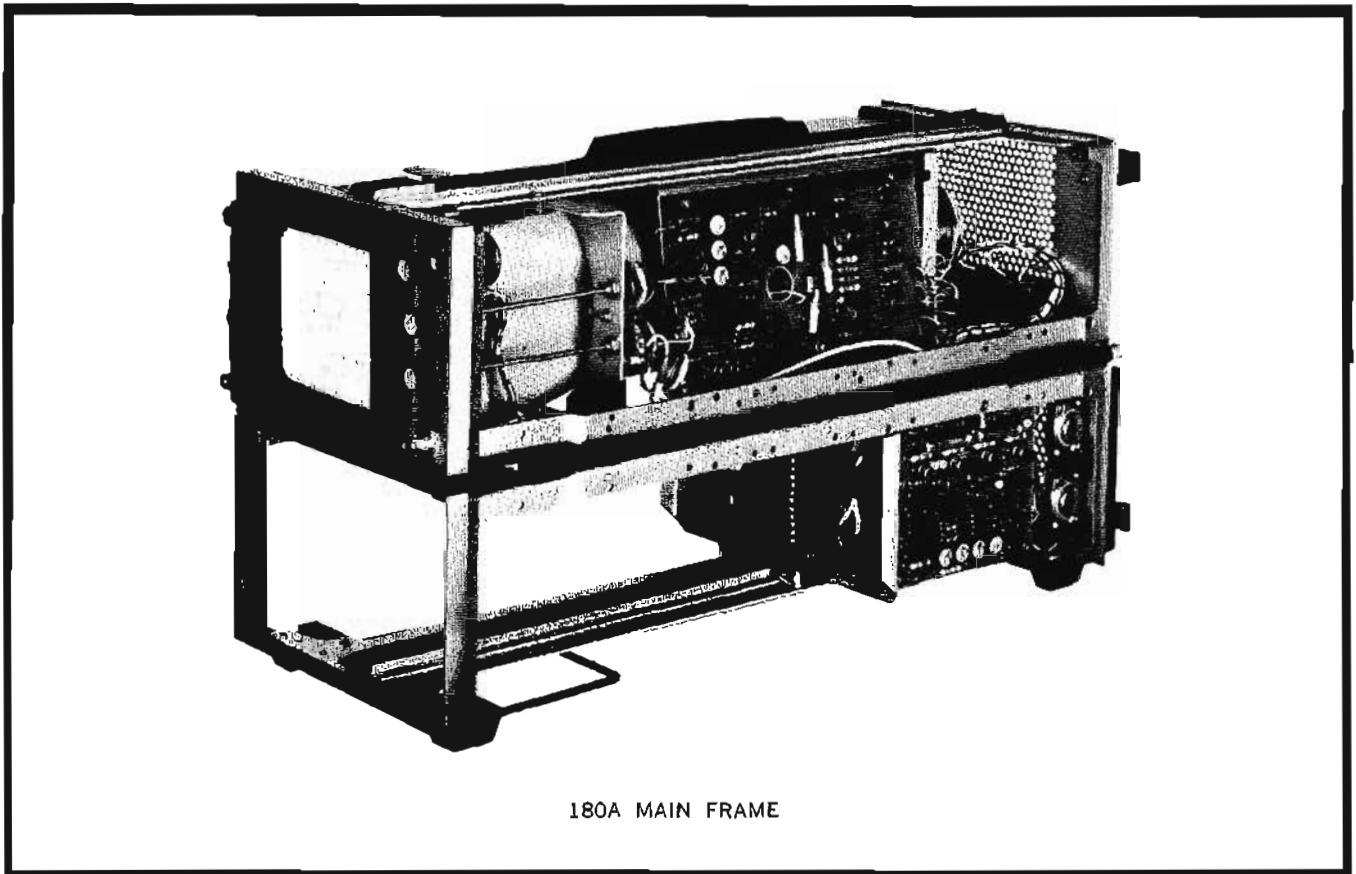

180A MAIN FRAME

## TIME BASE PLUG-INS

Triggering to 90 MHz, variable holdoff  
Models 1820A, 1821A



## OSCILLOSCOPES

### Time base plug-ins

The Model 1820A Time Base provides sweep speeds from 2 sec/cm to 50 nsec/cm, 5 nsec/cm when using Model 180A/AR X10 horizontal amplifier magnifier. Positive triggering is assured to 90 MHz and a front panel trigger holdoff control locks in complex waveforms. Automatic triggering provides a bright baseline in the absence of an input signal, and syncs on the input waveform when a vertical input signal is applied.

Model 1821A Time Base and Delay Generator provides sweeps from 1 sec/cm to 100 nsec/cm, 10 nsec/cm when using Model 180A/AR magnifier. It also features easy-to-use delayed sweeps. Exclusive Hewlett-Packard mixed sweep combines display of first portion of trace at normal sweep speeds, and simultaneously expands trailing portion of trace at faster delayed sweep speeds to allow magnified examination. Functional groupings of all controls simplifies operation. The internally generated delay trigger is available for external syncing.

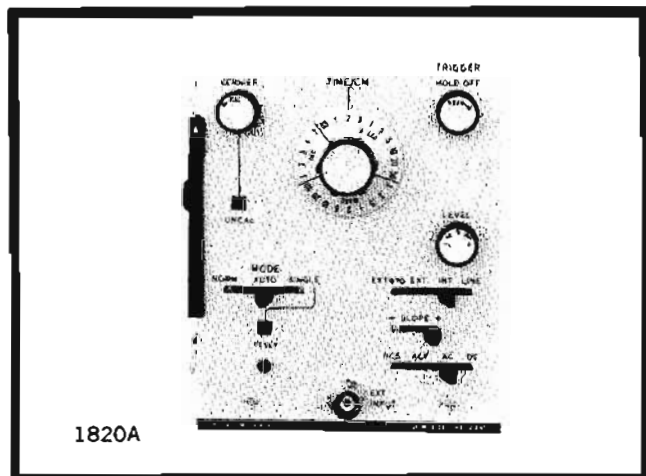

### Specifications, Model 1820A

**Time base:** 24 ranges, 0.05  $\mu$ sec/cm to 2 sec/cm in a 1, 2, 5 sequence; accuracy,  $\pm 3\%$ ; vernier provides continuous adjustment between steps and extends slowest step to at least 5 sec/cm; horizontal magnifier expands fastest step to 5 nsec/cm.

#### Triggering:

**Internal:** see vertical amplifier plug-in.

**External:** dc to 50 MHz from signals 0.5 V pk-pk or more increasing to 1 V at 90 MHz.

**Automatic:** bright base line displayed in absence of input signal; internal, from 40 Hz, see vertical amplifier specification; external from 40 Hz on signals 0.5 V pk-pk or more to greater than 50 MHz, increasing to 1 V at 90 MHz.

**Trigger point and slope:** controls allow selection of level and positive or negative slope; trigger level on external sync signal adjustable over range of  $\pm 5$  V,  $\pm 50$  V in  $\div 10$  position.

**Coupling:** ac, dc, acf, acs; ac attenuates signals below approx. 20 Hz; acf attenuates signals below approx. 15 kHz; acs attenuates signals above approx. 30 kHz.

**Single sweep:** front panel switch provides single sweep operation.

**Variable holdoff:** permits variation of time between sweeps to allow triggering on asymmetrical pulse trains.

**Weight:** net, 2 $\frac{3}{4}$  lbs (1,3 kg); shipping, 5 $\frac{1}{4}$  lbs (2,4 kg).

**Price:** HP Model 1820A, \$475.

### Specifications, Model 1821A

#### Main time base:

**Range:** 22 ranges, 0.1  $\mu$ sec/cm to 1 sec/cm in 1, 2, 5 sequence; accuracy,  $\pm 3\%$ ; vernier provides continuous adjustment between steps and extends slowest step to at least 2.5 sec/cm; horizontal magnifier expands fastest step to 10 nsec/cm.

#### Triggering:

**Internal:** see vertical amplifier plug-in.

**External:** dc to 50 MHz from signals 0.5 V pk-pk or more increasing to 1 V at 90 MHz.

**Automatic:** bright base line displayed in absence of an input signal; internal, from 40 Hz, see vertical amplifier specification; external, from 40 Hz on signals 0.5 V pk-pk or more to greater than 50 MHz increasing to 1 V at 90 MHz; and from line voltage.

**Trigger point and slope:** controls allow selection of level and positive and negative slope; trigger level on external sync signal adjustable over range of  $\pm 5$  volts,  $\pm 50$  V in  $\div 10$  position.

**Coupling:** ac, dc, acf, acs; ac attenuates signals below approx. 20 Hz; acf attenuates signals below approx. 15 kHz; acs attenuates signals above approx. 30 kHz.

**Trace intensification:** used for setting up delayed or mixed time base; increases in brightness that part of main time base to be expanded full screen in delayed time base; rotating delayed time base switch from Off position activates intensified mode.

**Delayed time base:** delayed time base sweeps after a time delay set by main time base and delay controls.

**Range:** 18 ranges, 0.1  $\mu$ sec/cm to 50 msec/cm in 1, 2, 5 sequence; accuracy,  $\pm 3\%$ ; vernier provides continuous adjustment between steps and extends slowest step to at least 125 msec/cm.

**Triggering:** applied to intensified Main, Delayed, and Mixed Time Base Modes.

**Automatic:** delayed time base starts at end of delayed period.

**Internal, external, slope, level, and coupling:** same as main time base triggering.

#### Delay (before start of delayed time base):

**Time:** continuously variable from 0.1  $\mu$ sec to 10 sec.

**Accuracy:**  $\pm 1\%$ ; linearity,  $\pm 0.2\%$ ; time jitter is less than 0.005% of maximum delay of each step (1 part of 20,000).

**Trigger output:** (at end of delay time) approximately 1.5 V with less than 50 nsec rise time from 1K ohm impedance.

**Mixed time base:** dual time base display in which main time base drives first portion of display and delayed sweep completes display at speeds up to 1000 times faster.

**Single sweep:** any display may be operated in single sweep.

**Weight:** net, 3 $\frac{3}{4}$  lbs (1,7 kg); shipping, 6 $\frac{1}{4}$  lbs (2,8 kg).

**Price:** HP Model 1821A, \$800.

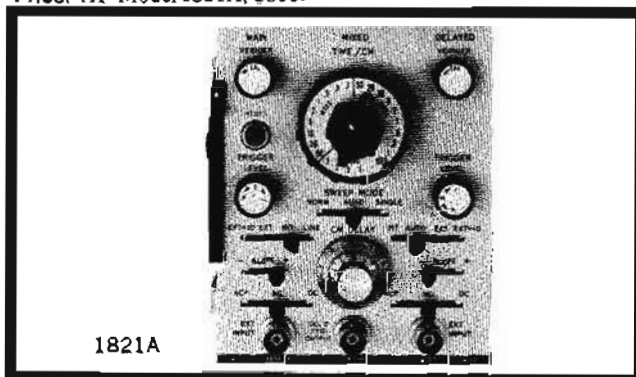



## 5 mV/cm AMPLIFIER; ACCESSORIES

50 MHz solid-state vertical amplifier

Model 1801A, 180A; accessories

### Model 1801A Vertical plug-in

This dual channel 50 MHz at 5 mV/cm vertical amplifier has low-drift FET input stages for accurate dc measurement ... plus quick, 15-second warm-up. Vertical attenuation, which sets vertical deflection factor, is ahead of the amplifier. This prevents trace jump as you change ranges; bandwidth is maintained on all ranges even when verniers are used. Internal triggering on the B channel signal assures time correlation for CHOP and ALT operation.

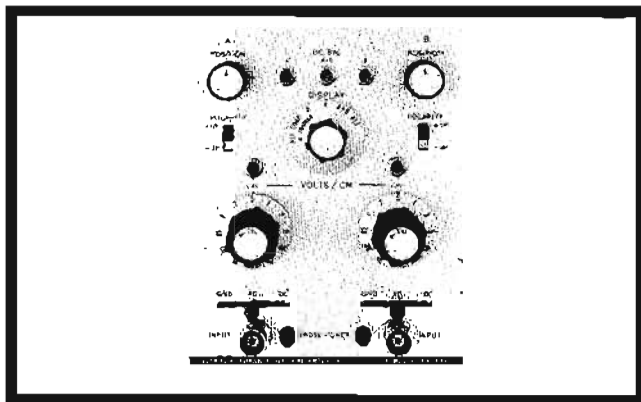

### Specifications

**Modes of operation:** Channel A alone; Channel B alone; Channels A and B displayed on alternate time bases; Channels A and B displayed by switching at approximately a 400 kHz rate, with blanking during switching; Channel A plus Channel B (algebraic addition).

**Each channel:**

**Bandwidth:** (direct or with probes 3 dB down from 8 cm

50 kHz reference signal) dc coupled, dc to 50 MHz; ac coupled, 2 Hz to 50 MHz.

**Rise time:** (direct or with probes) less than 7 nsec with 8 cm input step.

**Deflection factor (sensitivity):** 0.005 V/cm to 20 V/cm; 12 ranges in a 1, 2, 5 sequence; accuracy  $\pm 3\%$ ; vernier extends minimum sensitivity to 50 V/cm; a sensitivity calibration adjustment for each channel is provided on the front panel.

**Input RC:** 1 megohm shunted by approximately 25 pF.

**Maximum input:** 600 V peak ac coupled; dc coupled, 150 V at 5 mV/cm increasing to 350 V at 20 V/cm.

**Polarity presentation:** + or - up, selectable.

**A + B Input:**

**Amplifier:** bandwidth and deflection factor remain unchanged; either Channel A or B may be inverted to give A-B operation.

**Differential input (A-B):** common mode rejection at least 40 dB at 5 mV/cm, 20 dB on other ranges for frequencies up to 1 MHz; common mode signal should not exceed an amplitude equivalent to 50 cm.

**Triggering:**

**Mode:** Channel A or Channel B alone, or Channel A plus Channel B, on the signal displayed; Channel A and Channel B displayed by switching at approx a 400

**Frequency:** provides sufficient signal to the time base for triggering over the range of dc to 50 MHz with 0.5 cm pk-pk signal or more displayed on the CRT in all modes except CHOP; 100 kHz in CHOP.

**General:**

**Weight:** net, 4 lbs (1,8 kg); shipping, 6½ lbs (3 kg).

**Price:** HP Model 1801A, \$650.

### Model 1801A accessories

#### Model 1118A testmobile

The HP Model 1118A Testmobile for the Cabinet Model 180A provides adjustable height from 32 to 42 inches, 360° rotation, and instrument tilt from +45° to -45°. The Model 1118A with its large 3-inch locking wheels adds to the "go anywhere" feature of the Model 180A; price, \$95.

#### Model 10166A panel cover

The HP Model 10166A Panel Cover, made of fiberglass material, provides protection to the front panel controls of the Model 180A; price, \$25.

#### Model 10167A carrying cover

The HP Model 10167A Carrying Cover, made of flexible vinyl material, fits over the Cabinet Model 180A. The top of the cover is slotted for access to the carrying handle; price \$20.

#### Camera accessories

The HP Model 197A Camera fits the rectangular bezel of the Model 180A directly. See page 461 for accessories which adapt the HP Model 196A/B and the Tektronics C12 and C27 Oscilloscope Cameras to the Model 180A.





## TESTMOBILES

Store, transport test equipment conveniently  
Models 1116A, 1119A, 1117B



## OSCILLOSCOPES

Hewlett-Packard Testmobiles provide easy, convenient portability of test equipment to multiple test locations. These testmobiles can also be equipped to provide extra storage space for equipment and accessories which will increase test-bench working area.

### Model 1116A Testmobile

The Model 1116A is the basic, inexpensive testmobile. Its instrument rack can be tilted from horizontal to 30° above horizontal in four steps. The standard-equipment open wire basket can be used to hold bulky accessory equipment. This testmobile can also be folded for easy transportation to the test site or for more convenient storage.

**Dimensions:** 40" high, 20" wide, 24" deep (1016 x 508 x 610 mm).

**Weight:** net, 34 lbs (15,3 kg); shipping, 42 lbs (18,9 kg).

**Price:** Model 1116A Testmobile, \$85.

### Model 1119A Testmobile

The Model 1119A Testmobile, for standard Hewlett-Packard modular instruments, has a unique trunnion mounting that allows the instrument to be rotated a full 360°. The dented tilt positions are located at 10° intervals. Instruments larger than ten inches from pivot point to corner can be tilted  $\pm 40^\circ$  from the horizon.

When working with non-modular equipment, a Model 10479A Tilt Tray can be mounted on the testmobile.

For more storage space, the Model 10480A cabinet can be quickly mounted in place of the lateral brace. This cabinet has adequate space for plug-ins and small instruments. The cabinet also is equipped with a 1 $\frac{5}{8}$ " drawer for cables and accessories.

**Dimensions:** 38" high, 19 $\frac{1}{4}$ " wide, 23 $\frac{1}{2}$ " deep (965 x 489 x 597 mm).

**Weight:** net, 42 lbs (19,1 kg); shipping, 50 lbs (22,5 kg).

**Price:** Model 1119A Testmobile, \$110.

### Model 10480A Storage Cabinet

**Dimensions:** 11 $\frac{1}{4}$ " high, 18 $\frac{1}{4}$ " wide, 15" deep (286 x 464 x 381 mm).

**Weight:** net, 19 $\frac{1}{2}$  lbs (8,9 kg); shipping, 22 $\frac{1}{2}$  lbs (10 kg).

**Price:** Model 10480A Storage Cabinet, \$35.

### Model 10479A Tilt Tray

For use with instruments other than standard Hewlett-Packard modular size.

**Dimensions:** 17 $\frac{1}{4}$ " wide, 23" deep.

**Weight:** net, 12 lbs (5,5 kg); shipping, 15 lbs (6,8 kg).

**Price:** Model 1117B Testmobile (without drawers), \$185.

### Model 1117B Testmobile

The Model 1117B Testmobile can be equipped as a complete, portable test center. The top instrument tray can be tilted from 15° below to 30° above the horizontal in 7 $\frac{1}{2}$ ° steps. The front or rear frame can accommodate standard 19 inch RETMA rack panels so that any necessary equipment can be carried with the testmobile. In addition, HP Combining Cases or Rack Adapter Frames may be mounted on the testmobile to accommodate any sub-modular components.

Central power distribution to the instruments is provided by four standard NEMA plugs on the back panel.

Two storage drawers are also separately available—a three inch drawer for small accessories; and an eight inch drawer for bulky items such as plug-ins. Both drawers can be removed or repositioned at the option of the user.

**Dimensions:** 39" high, 20" wide, 24" deep (991 x 508 x 610 mm).

**Weight:** net, 85 lbs (38,3 kg); shipping, 117 lbs (52,7 kg).

**Price:** Model 1117B Testmobile (without drawers), \$185.

### Model 10475A 3-inch Drawer

**Weight:** net, 9 lbs (4,1 kg); shipping, 13 lbs (5,9 kg).

**Price:** Model 10475A, \$30.

### Model 10476A 8-inch Drawer

**Weight:** net, 11 lbs (5 kg); shipping, 25 lbs (11,3 kg).

**Price:** Model 10476A, \$35.

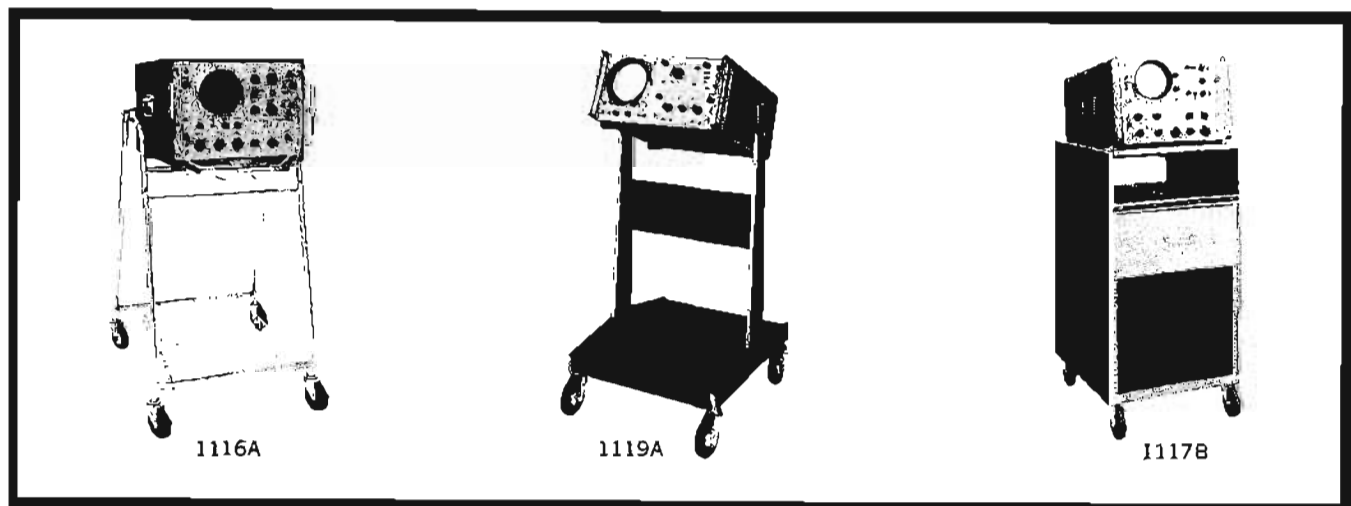



## OSCILLOSCOPE CAMERA

Permanent records of oscilloscope traces  
Model 197A

The Model 197A Oscilloscope Camera provides an accurate, convenient way of recording oscilloscope displays. It is a precision instrument, meant for long, hard use.

The Model 197A employs a new electronic shutter which provides accurate exposure times from 1/30 to 4 sec. The shutter may be tripped electrically from a remote source, and a sync output provides a contact closure when the shutter is opened, allowing synchronizing of other equipment with the camera. Circuitry is all solid-state.

The new  $f/1.9$  lens, designed for Hewlett-Packard by Wollensak, is mounted in a direct line with the film and transmits a maximum amount of light for photography of dim traces.

An ultra-violet light is included in the Model 197A for illuminating the internal graticule used on HP oscilloscopes. The "black" light, adjustable in intensity to suit conditions, excites the phosphor on the tube face and causes it to photograph an intermediate gray. The gray background clearly distinguishes the thin black graticule lines by contrast. Trace intensity is not degraded by this induced fluorescence, and the resulting photographs are actually easier to read, since the black graticule lines also contrast clearly with the trace, and their exact crossings can be accurately located. This black light has the additional advantage of presensitizing the film at the same time that the photograph is taken. The uniform glow of the CRT face lowers the apparent threshold sensitivity of the film, enabling it to record dimmer traces and making possible clear, sharp photographs of both repetitive and single sweep phenomena (see Figure 1). In addition to continuously adjustable ultraviolet intensity, the Model 197A also provides a "flash" feature which automatically turns the UV on and off. The "flash" permits recording of slow single-shot events and complete graticule information in a single exposure. In other cameras a double exposure is usually required.

All Model 197A controls are located outside the camera. Shutter speed, f-stop, and UV light brightness are color coded to provide an optimum starting point for the inexperienced photographer. The lightweight Model 197A is

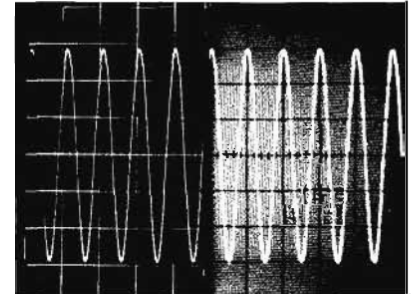

Figure 1. "Half-and-half" photo made with special cathode ray tube compares photographic qualities of conventional external graticule (left) and UV-lighted internal graticule.

quickly and easily mounted on any oscilloscope, and swings away from the CRT face when not needed. The face-fitting, flexible hood has a low viewing angle for accurate alignment of the trace with an external graticule. The hood may be removed and replaced with a flat panel, allowing a series of cameras to be mounted on stacked oscilloscopes with heights as low as 7 inches.

The Model 197A back may be rotated from the normal horizontal position to a vertical position, allowing two smaller pictures to be taken on one photograph. The back also can be moved through 11 detented positions for multiple exposures (see Figure 2) or it can be removed and replaced with a 4 x 5 inch Graflok® back. The entire film area of the back may be utilized through the use of the Model 197A's easily adjustable continuous reduction ratio feature. The camera may then be quickly refocused with a simple knob adjustment, using the furnished split image focusing plate stored in the camera.



197A

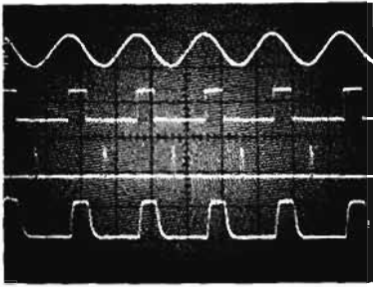

Figure 2. Multiple exposure photographs are easily made with the Model 197A Camera.

### Specifications

**Reduction ratio:** continuously adjustable from 1:1 to 1:0.7; reference scale provided on focus plate.

**Lens:** 75 mm,  $f/1.9$  high transmission lens, manufactured exclusively for HP by Wollensak; aperture ranges  $f/1.9$  to  $f/16$ ; optional 88 mm  $f/1.4$  OscilloRaptar lens available.

**Shutter:** electronically operated and timed shutter, with all solid-state circuitry; shutter speeds are 1/30, 1/15, 1/8, 1/4, 1/2, 1, 2, 4 sec, Time and Bulb; shutter has a sync contact closure output for triggering external equipment, and input jack for remote operation.

**Camera back:** Polaroid® Land Camera using pack film Type 107 supplied; Graflok® back available (see Options); backs

may be interchanged without refocusing and may be rotated in 90-degree increments.

**Mounting:** quick lift on-off mounting with positive lock; swing away to left.

**Viewing:** low-angle, direct viewing flexible face mask; hood may be removed and replaced with panel to allow stacking on 7-inch high oscilloscopes (see Accessories Available).

**Multiple exposure:** back moves vertically through 11 detented positions at  $\frac{1}{2}$  cm per detent at 1:0.9 object-to-image ratio.

**Focus:** adjustable focusing with lock; split image focusing plate provided.

**Dimensions:** 14" long,  $10\frac{1}{2}$ " high,  $7\frac{3}{8}$ " wide (356 x 267 x 194 mm) with hood; 12" long,  $6\frac{1}{2}$ " high,  $7\frac{3}{8}$ " wide (305 x 165 x 194 mm) without hood.

**Weight:** net 10 lbs (4.5 kg); shipping 19 lbs (8.6 kg).

**Power:** 115 V  $\pm 10\%$ , 50 to 1000 Hz, 6 watts.

**Accessories furnished:** combination split image focusing plate and reduction ratio scale.

**Price:** HP Model 197A, \$475.

**Option 01:** without ultraviolet light, deduct \$50.

**Option 02:**  $f/1.4$  lens, add \$270.

**Option 03:** Graflok back in place of Polaroid back; no charge.

**Option 12:** modified for 230 V operation; no charge.

"Polaroid"® by Polaroid Corp.  
"Graflok"® by Graflex, Inc.

### Camera accessories available

#### Camera Backs



The Model 197A is supplied with a Polaroid® Pack Film back as standard or a 4 x 5 Graflok® back as Option 03. These backs can also be ordered separately. Polaroid back Model 10353A, \$85; Graflok back Model 10352A, \$85.

#### Oscilloscope Bezel Adapters

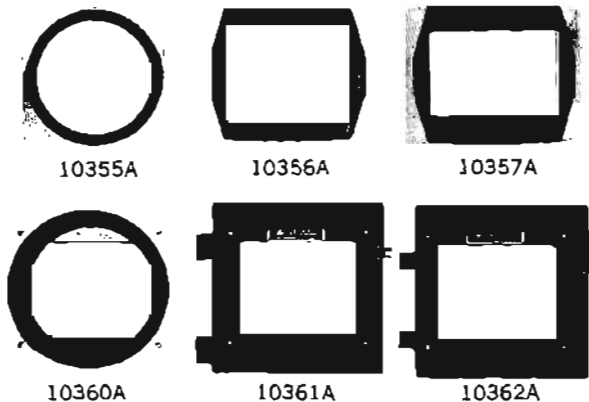

The Model 197A fits all HP oscilloscopes and can easily be fitted to other types by means of bezel adapters. Model 10355A adapts to Tektronix and Fairchild 5-inch round bezels, \$15. Model 10356A adapts to Tektronix 560 Series rectangular bezels, \$15. Model 10357A adapts to Tektronix 640 Series rectangular bezels, \$15. The Model 10360A adapts the Model 196A/B camera to the HP rectangular bezel, \$15. The Model 10361A adapts the Tektronix C12 camera to the HP rectangular bezel, \$15. The Model 10362A adapts the Tektronix C27 camera to the HP rectangular bezel, \$15.

#### Carrying Case

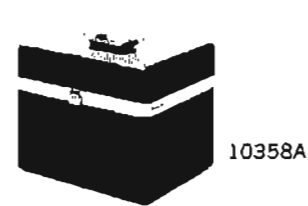

The Model 10358A carrying case is a sturdy fiber-glass and aluminum construction with foam padding to provide maximum protection for the Model 197A in transit or storage, \$65.

#### Other accessories

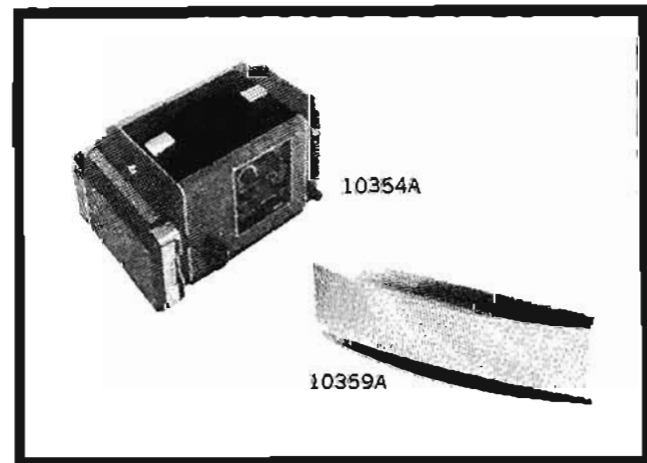

Model 10354A Viewing Hood Replacement Plate is used in place of the Model 197A viewing hood and permits camera mounting on stacked oscilloscopes with heights as low as 7 inches, \$7.

The Model 10359A Viewing Lens is a ground plastic lens which fits inside the viewing hood for easy trace viewing by those with farsighted vision, \$25.

# OSCILLOSCOPES



## CAMERA; ACCESSORIES

Convenient recording of oscilloscope traces  
Models 196A, 196B; Accessories

### Model 196A/B Cameras

Advantages of the Model 196A/B include sharp definition and high resolution  $f/1.9$  lens; easy-to-use Polaroid Land Film-Pack Back; prefocused for convenient operation; no image inversion; quick-release clamp for easy mounting; distortion is imperceptible; internal UV light with Model 196B.

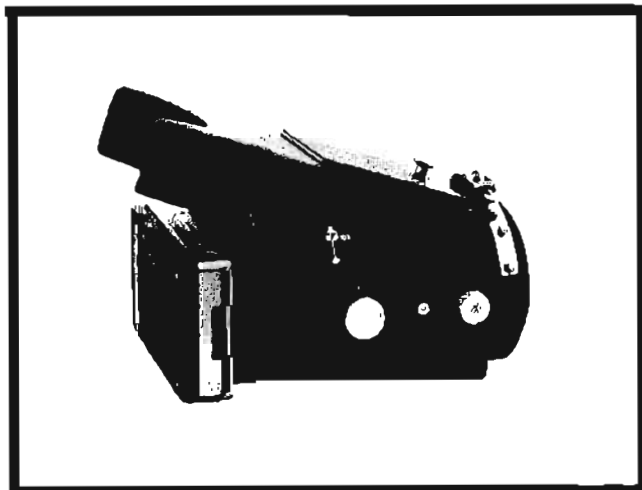

### Specifications, Model 196A/B

**Object-to-image-ratio:** 1-to-0.9; 1-to-1 optional.  
**Lens:** 75 mm,  $f/1.9$  high-resolution lens.  
**Focus:** factory-set for optimum resolution of both trace and graticule.  
**Lens opening:**  $f/1.9$  to  $f/16$ .  
**Shutter:** speed and  $f$ -stop settings are completely visible and adjustable from access port; shutter speeds are 1/50, 1/25, 1/10, 1/5, 1/2, 1 sec., Time, Bulb (solenoid operation on special order).  
**Print size:**  $3\frac{1}{4}'' \times 4\frac{1}{4}''$  (83 x 108 mm).  
**Image size:**  $2\frac{7}{8}'' \times 3\text{-}13/16''$  (73 x 96 mm).  
**Film:** Polaroid® Land Film Pack, Type 107, 3000 speed.  
**Dimensions:** 10" wide,  $13\frac{1}{2}''$  long,  $10\frac{1}{4}''$  high, (254 x 343 x 262 mm).  
**Weight:** net, 9 lbs (4.1 kg); shipping, 18 lbs (8.1 kg); 32 lbs (14.9 kg) with carrying case.  
**Power:** Model 196B, 115 V  $\pm 10\%$ , 60 Hz, 10 W.  
**Accessories available:** Model 10351A Carrying Case, \$40; Model 10355A Tektronix Adapter, \$15.  
**Price:** HP Model 196B, \$445; HP Model 196A (identical with Model 196B, but without black light source), \$395.  
**Special order:** 1:1 object-to-image-ratio, add \$25; and order C01-196A for Model 196A, C06-196B for Model 196B; solenoid-operated shutter for remote operation (actuated by external contact closure), 115 V ac external power required, add \$125 and order H05-196A for Model 196A, H05-196B for Model 196B; solenoid operation same as above, except 28 V dc external power required, add \$65 and order H01-196A for Model 196A, H06-196B for Model 196B.  
**Conversion kits:** 196A-95C, converts "A" to "B"; price, \$50; 196A-95D, same as above but with Option 12; price, \$65.  
**Option 12:** Model 196B for 115 or 230 V  $\pm 10\%$ , 50 to 60 Hz operation, add \$15.

®by Polaroid Corporation

### Oscilloscope accessories



10110A



10111A

The Model 10110A Adapter (BNC male to dual-banana-post) quickly converts standard BNC input terminals on oscilloscopes to dual banana posts; price, \$5.

The Model 10111A Adapter (shielded banana-post to female-BNC) converts banana post inputs on oscilloscopes to shielded BNC inputs for low-level signal work; price, \$7.



10175A



10175B

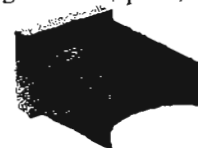

10176A

The Model 10175A polarized hood increases contrast and reduces glare for viewing dim traces under all ambient light conditions; price, \$10.

The Model 10175B hood with removable vinyl face mask is ideal for viewing fast transients; price, \$15.

The Model 10176A flexible viewing hood is designed for use on the HP rectangular bezels; price, \$7.



HP Model	Length	Description	Price
10120A	3' (91 cm)	male BNC-to-male BNC	\$10
10121A	8" (203 mm)	male BNC-to-male BNC	\$10
10122A	3' (91 mm)	male BNC-to-male Type N	\$10
10123A	6' (183 cm)	male BNC-to-male BNC	\$11
10124A	9' (274 cm)	male BNC-to-male BNC	\$12
10126A	18' (549 cm)	male BNC-to-male BNC	\$13
10127A	1' (305 mm)	GR-to-male BNC	\$13
10128A	1' (305 mm)	GR-to-female BNC	\$13

**PRODUCT CATEGORY INDEX**



**DC POWER SUPPLIES**

**Bench Supplies\***

Page

LAB Series laboratory supplies	output	0-7.5 V 0-3 A	0-20 V, 0-0.6 A 0-40 V, 0-0.3 A	0-20 V, 0-0.6 A 0-40 V, 0-0.3 A	0-20 V, 0-1.5 A	0-20 V, 0-1.5 A 0-40 V, 0-0.75 A	0-30 V, 0-1 A 0-60 V, 0-0.5 A	0-40 V, 0-0.75 A	0-160 V, 0-0.2 A	0-320 V, 0-0.1 A		470, 471
	model	6203B	6204B	(dual) 6205B	6201B	6203B	6206B	6202B	6207B	6209B		
MPB-3, MPB-5 Series, medium power	output	0-7.5 V 0-5 A	0-10 V, 0-10 A	0-20 V, 0-3 A	0-20 V, 0-5 A	0-20 V, 0-10 A	0-40 V, 0-1.5 A	0-40 V, 0-3 A	0-60 V, 0-1 A	0-60 V, 0-3 A	0-100 V, 0-750 mA	474, 475
	model	6281A	6282A	6284A	6285A	6286A	6289A	6290A	6291A	6294A	6296A 6299A	
MPM Series medium power modular	output	0-24 V, 0-3 A	0-75 V, 0-1.5 A 0-50 V, 0-75 A	0-50 V 0-1.5 A								473
	model	6224B	6220B	6226B								
STB Series high stability laboratory supplies	output	0-20 V, 0-1 A	0-40 V, 0-0.5 A	0-100 V, 0-200 mA	0-3000 V, 0-6 mA	0-10 V, 0-2 A						476, 477
	model	6101A, 6111A	6102A, 6112A	6106A, 6116A	6110A	6113A						
HVB Series high voltage	output	0-1600 V 0-5 mA	0-3000 V 0-6 mA									472
	model	6515A	6516A									
CCB Series constant current	output	0-50 V 0-750 mA	0-100 V 0-300 mA	0-300 V 0-100 mA								478, 479
	model	6177A	6181A	6186A								
Medium voltage multiple output	output	0-500 V, 0-0.1 A and 12.6/6.3 V ac		0-500 V, 0-0.2 A; -300 V, 0.05 A; 0 to -150 V, .006 A; 12.6/6.3 V ac								491
	model	711A		712B								

**Rack Supplies**

DPR Series dual power	output	0-7.5 V, 0-5 A	0-20 V, 0-3 A	0-40 V, 0-1.5 A	0-60 V, 0-1 A	0-100 V 0-750 mA						474, 475
	model	6251A	6253A	6255A	6257A	6258A						
LVR Series low voltage	output	0-10 V, 0-100 A	0-18 V, 0-10 A	0-18 V, 0-20 A	0-36 V, 0-3 A	0-36 V, 0-5 A	0-36 V, 0-10 A	0-40 V, 0-30 A	0-40 V, 0-50 A	0-60 V, 0-3 A	0-60 V, 0-15 A	482, 483
	model	6260A	6263A	6264A	6265A	6266A	6267A	6268A	6269A	6271A	6274A	
MVR Series medium voltage	output	0-320 V 0-600 mA	0-320 V 0-1.5 A									484
	model	890A	895A									
HVR Series high voltage	output	0-1000 V 0-700 mA	0-7000 V 0-100 mA	0-1000 V 0-50 mA								484
	model	6521A	6522A	6525A								
SCR-IP Series	output	0-20 V, 0-15 A	0-20 V, 0-45 A	0-36 V, 0-10 A	0-60 V, 0-5 A	0-60 V, 0-15 A	0-120 V, 0-2.5 A	0-600 V, 0-1.5 A				485
	model	6427B	6428B	6433B	6436B	6439B	6443B	6448B				
SCR-3 Series	output	0-15 V, 0-200 A	0-36 V, 0-100 A	0-54 V, 0-50 A								486
	model	6453A	6456B	6459A								
SCR-10 Series	output	0-4 V, 0-2000 A	0-8 V, 0-1000 A	0-16 V, 0-600 A 0-18 V, 0-500 A	0-36 V, 0-300 A	0-64 V, 0-150 A	0-110 V, 0-100 A	0-220 V, 0-50 A	0-300 V, 0-35 A	0-440 V, 0-25 A 0-500 V, 0-20 A 0-600 V, 0-15 A		487
	model	6463A	6464A	6466A	6469A	6472A	6475A	6477A	6479A	6483B		

**Special Products**

ICS Series low voltage, rack, for integrated circuits	output	4-5.5 V, 0-8 A	0-7.5 V, 0-15 A	0-7.5 V, 0-30 A	0-7.5 V, 0-60 A	0-7.5 V, 0-120 A						480, 481
	model	6384A	6385A	6386A	6387A	6388A						
MOD Series modular plug-in power supplies	output	0-18 V, 0-300 mA	0-18 V, 0-1 A	0-18 V, 0-2.5 A	0-36 V, 0-150 mA	0-36 V, 0-500 mA	0-36 V, 0-1.5 A	0-160 V, 0-400 mA	0-320 V, 0-200 mA			488, 489
	model	6343A	6344A	6346A	6347A	6348A	6349A	6354A	6357A			
SLOT Series fixed output modules	output	6 V, 0-3.5 A	12 V, 0-1 A	12 V, 0-2.2 A	—	24 V, 0-1 A	28 V, 0-1.5 A					490
	model	60065A	60123A	60125A	—	60244A	60285A					
Strain gage supply	output	0-25 V, 0-0.2 A										491
	model	801C										
Klystron power supplies	output	0 to -900 V, -250 to -400 V, 6.3 V ac				0 to -800 V, -250 to -800 V, 6.3 V dc						492
	model	715A				716B						
PS/A Series dc power supply and amplifier	output	power supply	-20 V to +20 V, 0-0.5 A				-50 V to +50 V, 0-1 A					493
	amplifier	40 V p-p, 0-0.5 A				100 V p-p, 0-1 A						
	model	6823A				6824A						

\*These supplies can also be rack mounted. Refer to pages indicated for details.



The following is a step-by-step procedure which, when used with the Condensed Listing on the following pages and the Definitions on pages 468 and 469 will be helpful in choosing the right power supply.

### (1) Determine dc output voltage rating

A dc voltage requirement is often expressed as a nominal rating, but power supplies are rated in terms of maximum output under worst operating conditions. For example, if the dc voltage required is nominally 32 volts, adjustable  $\pm 10\%$ , a 36 volt supply (not 32 volts) should be obtained, provided operation is actually desired at 110% of nominal (35.2 volts). This can be important if "marginal checking" of a system or a load circuit is to be accomplished by varying the dc power supply feeding it.

### (2) Determine dc output current rating

The output current rating of a power supply must be selected on the basis of the peak current requirement, not the average current requirement; this results from the fact that the current limiting protection circuitry internal to the supply is extremely fast in order to protect the series power transistors. The current limit circuit is normally adjustable to between 105 and 110% of the nominal current rating of the power supply. If inverse current loading is involved, the power supply must have a current rating equal to or greater than the sum of peak current delivered and peak current absorbed.

### (3) Consult condensed listing

Enter the Condensed Listing at the voltage rating found from (1). Supplies above this point are eliminated from consideration because of insufficient output voltage. Many supplies below this point are also eliminated because of a current rating too small compared with (2). If the desired output voltage-current combination does not appear in the Condensed Listing, consider series and parallel combinations of power supplies: Hewlett-Packard's Auto-Series and Auto-Parallel feature permits one knob control and equal voltage and current sharing.

### (4) Constant voltage and/or constant current output

Most applications require constant voltage power supplies. However, some load devices require a constant current source of dc power. Still other applications (e.g. battery charging and electrolytic capacitor forming) call for supplies which have automatic crossover between constant voltage and constant current operation.

If the requirement involves constant current performance, then the Condensed Listing should be used to determine which supplies remaining from (3) are capable of

constant current operation. Remember that all Remote Programming constant voltage supplies can also be converted to constant current use with one external resistor.

### (5) Specifications for load regulation, line regulation, ripple and transient response

Generally speaking, a Hewlett-Packard power supply employs one of two basic circuit techniques — (1) a transistor regulator, or (2) an SCR regulator. (In the case of high power output rating, the transistor regulator is preceded by an SCR preregulator.) All low output power supplies use circuit technique (1), since this results in both lower cost and better performance. Either circuit technique (1) or (2) may be utilized in a supply of moderate output power capability. Power supplies of very high output power employ circuit technique (2).

These two circuit techniques result in distinctly different performance characteristics — particularly with regard to regulation, ripple and transient response.

Specification	Transistor Regulated	Specification	SCR Regulated
Load Regulation	0.001% to 0.05%	Load Regulation	0.1% to 1%
Line Regulation	0.001% to 0.05%	Line Regulation	0.1% to 1%
Ripple and Noise	50 $\mu$ v to 1 mv	Ripple and Noise	0.1% to 1%
Transient Response	Less than 50 $\mu$ sec.	Transient Response	Less than 50-200 msec.

### (6) Is remote programming required?

If it is desired to control the output of the power supply remotely using switched or variable values of resistance, or if the supply is to be controlled by means of a voltage input, then look on the Condensed Listing for those power supplies with a check under "Remote Programming."

### (7) Physical configuration

Power supplies are available in three basic packages — rack mounting (standard 19" RETMA), bench, and modular. For high output ratings, rack mounting is the only practical configuration. All supplies which are not normally rack mounting are easily adapted to rack applications using standard hardware available from Hewlett-Packard. Reference to the appropriate catalog pages will indicate the nature and cost of this rack mounting adapting hardware.

### (8) Miscellaneous requirements

Depending on the particular application, check also for remote error sensing, permissible values of input line voltage and frequency, front and/or rear output terminals, meters, etc. Many of these miscellaneous requirements can be checked directly on the Condensed Listing. In other cases it will be necessary to refer to the more de-

tailed information on the catalog pages referenced by the Condensed Listing.

A spec sheet can be obtained from any Hewlett-Packard sales office.

### Power supply series designations

Series designations identify groupings of Hewlett-Packard power supplies that have similar circuit techniques and operating characteristics.

The model numbers assigned to each Series can be determined from the Product Category Index on page 465.

Note that each multiple letter Series designation (1) suggests the general type of power supply in a given category and (2) indicates (in the third letter) the nature of the power supply case and its "normal" mode of installation. A final "B" indicates Bench supplies and a final "R" applies to units which are Rack mounted. Absence of a "B" or an "R" as the final letter means that the supplies have not been designed primarily for either Bench or Rack use, or that the series includes both full rack width and half rack width instruments.

Notice that these designations are not part of the model number. They do not appear on the instrument and should not be used when ordering.

SERIES	Description
CCB	Constant-Current, Bench
DPR	Dual Power Rack
HVB	High Voltage Bench
HVR	High Voltage Rack
IGS	Low Voltage for Integrated Circuits
LAB	Laboratory Bench
LVR	Low Voltage Rack
MOD	Plug-In Modular
MPB-3	3 1/2" High Medium Power Bench
MPB-6	5 1/2" High Medium Power Bench
MPM	Medium Power Modular
MVR	Medium Voltage Rack
PS/A	Power Supply/Amplifier
SCR-1P	Primary SCR Regulated, Output Ratings — 300 and 900 Watts
SCR-3	SCR Regulated, Output Ratings up to 3 KW
SCR-10	SCR Regulated, Output Ratings up to 10 KW
SLOT	Fixed Output Modules
STB	High Stability Bench Supplies

Further information on power supplies can be found in Application Note 90, Power Supply Handbook, available from your local Hewlett-Packard Sales Office.

## CONDENSED LISTING



## DC POWER SUPPLIES

Output volts	Output amps	Model	Series	Catalog page	Load regulation (mV)	Line regulation (mV)	RMS ripple & noise (mV)	Input line voltage (Vac)	Input line frequency	Remote programming	Bench or Rack*	CV/CC**	Price
0-4	0-2000	6463A	SCR-10	487	50 mV combined		280	3 $\phi$ 208/220/460 $\pm$ 10%	57-63	$\checkmark$	R	$\checkmark$	\$3500
4-5.5	0-8	6384A	ICS	480-481	1 mV	1 mV	1 mV	105-125 or 210-250	48-63		B		220
6 $\pm$ 10%	0-3.5	60065A	SLOT	490	0.05%	0.05%	1 mV	105-125	48-440		R		See pg 490
0-7.5	0-3	6203B	LAB	470-471	5 mV	3 mV	0.2	105-125 or 210-250	50-400	$\checkmark$	B	$\checkmark$	169
0-7.5 Dual	0-5	6251A	DPR	474-475	5 mV	2 mV + 0.01%	0.2	105-125 or 210-250	50-400	$\checkmark$	R	$\checkmark$	445
0-7.5	0-5	6281A	MPB-3	474-475	5 mV	2 mV + 0.01%	0.2	105-125 or 210-250	50-400	$\checkmark$	B	$\checkmark$	210
0-7.5	0-15	6385A	ICS	480-481	1 mV	1 mV	1 mV	115/208/230	48-63	$\checkmark$	R	$\checkmark$	450
0-7.5	0-30	6386A	ICS	480-481	1 mV	1 mV	1 mV	115/208/230	48-63	$\checkmark$	R	$\checkmark$	700
0-7.5	0-60	6387A	ICS	480-481	1 mV	1 mV	1 mV	115/208/230	48-63	$\checkmark$	R	$\checkmark$	825
0-7.5	0-120	6388A	ICS	480-481	1 mV	1 mV	1 mV	208/230	48-63	$\checkmark$	R	$\checkmark$	1050
0-8	0-1000	6464A	SCR-10	487	25 mV combined		80	3 $\phi$ 208/230/460 $\pm$ 10%	57-63	$\checkmark$	R	$\checkmark$	3300
0-10	0-2	6113A	STB	476-477	0.001% + 1.1 mV	0.001%	0.04	105-125 or 210-250	48-63	$\checkmark$	B		375
0-10	0-10	6282A	MPB-5	474-475	1 mV + 0.01%	1 mV + 0.01%	0.5	105-125	50-60	$\checkmark$	B	$\checkmark$	350
0-10	0-100	6260A	LVR	482-483	200 $\mu$ V + 0.01%	200 $\mu$ V + 0.01%	1.0	230 $\pm$ 10%	48-63	$\checkmark$	R	$\checkmark$	775
12 $\pm$ 10%	0-1	60123A	SLOT	490	0.05%	0.05%	1 mV	105-125	48-440		R		See pg 490
12 $\pm$ 10%	0-2.2	60125A	SLOT	490	0.05%	0.05%	1 mV	105-125	48-440		R		See pg 490
0-15	0-200	6453A	SCR-3	486	10 mV + 0.2% combined		150	3 $\phi$ 208/230/460 $\pm$ 10%	57-63	$\checkmark$	R	$\checkmark$	1375
0-16 or 0-18	0-600 or 0-500	6486A	SCR-10	487	10 mV + 0.2% combined		160 or 180	3 $\phi$ 208/230/460 $\pm$ 10%	57-63	$\checkmark$	R	$\checkmark$	2600
0-18	0-0.3	6343A	MOD	488-489	3 mV or 0.03%	3 mV or 0.03%	1.0	105-125 or 210-250	48-440	$\checkmark$	R		120
0-18	0-1	6344A	MOD	488-489	3 mV or 0.03%	3 mV or 0.03%	1.0	105-125 or 210-250	48-63	$\checkmark$	R		165
0-18	0-2.5	6345A	MOD	488-489	3 mV or 0.03%	3 mV or 0.03%	1.0	105-125 or 210-250	48-63	$\checkmark$	R		225
0-18	0-10	6263A	LVR	482-483	200 $\mu$ V + 0.01%	200 $\mu$ V + 0.01%	0.5	100-130 or 200-260	48-63	$\checkmark$	R	$\checkmark$	435
0-18	0-20	6264A	LVR	482-483	200 $\mu$ V + 0.01%	200 $\mu$ V + 0.01%	0.5	100-130 or 200-260	48-63	$\checkmark$	R	$\checkmark$	525
-20 to +20	0-0.5	6823A	PS/A	493	5 mV + 0.02%	5 mV + 0.02%	2	105-125 or 210-250	50-440	$\checkmark$	B	$\checkmark$	194
0-20	0-0.6	6204B	LAB	470-471	4 mV + 0.01%	4 mV + 0.01%	0.2	105-125 or 210-250	50-400	$\checkmark$	B		144
0-20 and 0-40	0-0.6 and 0-0.3	6205B	LAB	470-471	4 mV + 0.01%	4 mV + 0.01%	0.2	105-125 or 210-250	50-440	$\checkmark$	B	$\checkmark$	235
0-20	0-1	6101A	STB	476-477	600 $\mu$ V + 0.001%	0.001%	0.04	105-125 or 210-250	48-63	$\checkmark$	B		265
0-20	0-1	6111A	STB	476-477	600 $\mu$ V + 0.001%	0.001%	0.04	105-125 or 210-250	48-63	$\checkmark$	B		375
-	-	-	-	-	-	-	-	-	-	-	-	-	-
0-20	0-1.5	6200B	LAB	470-471	4 mV + 0.01%	4 mV + 0.01%	0.2	105-125 or 210-250	50-400	$\checkmark$	B	$\checkmark$	189
0-20	0-1.5	6201B	LAB	470-471	4 mV + 0.01%	4 mV + 0.01%	0.2	105-125 or 210-250	50-400	$\checkmark$	B	$\checkmark$	169
0-20 Dual	0-3	6253A	DPR	474-475	4 mV + 0.01%	2 mV + 0.01%	0.2	105-125 or 210-250	50-400	$\checkmark$	R	$\checkmark$	445
0-20	0-3	6284A	MPB-3	474-475	4 mV + 0.01%	2 mV + 0.01%	0.2	105-125 or 210-250	50-400	$\checkmark$	B	$\checkmark$	210
0-20	0-5	6285A	MPB-5	474-475	1 mV + 0.01%	1 mV + 0.01%	0.5	105-125	50-60	$\checkmark$	B	$\checkmark$	350
0-20	0-10	6286A	MPB-5	474-475	1 mV + 0.01%	1 mV + 0.01%	0.5	105-125	50-60	$\checkmark$	B	$\checkmark$	395
0-20	0-15	6427B	SCR-1P	485	20 mV	10 mV	40	105-125	57-63	$\checkmark$	R	$\checkmark$	380

\*\*"B" indicates bench type and "R" indicates full rack width type supplies. All bench supplies (except Models 721A, 711A, 712B and 715A) can be rack mounted using accessory rack mounting hardware.

\*\*Automatic crossover between constant voltage (cv) and constant current (cc) operation.

additional listings on next page



## DC POWER SUPPLIES



## CONDENSED LISTING

Output volts	Output amps	Model	Series	Catalog page	Load regulation (mV)	Line regulation (mV)	RMS ripple & noise (mV)	Input line voltage (Vac)	Input line frequency	Remote programming	Bench or Rack*	CY/CC**	Price
0-20	0-45	6428B	SCR-1P	485	40 mV	20 mV	40	105-125	57-63	✓	R	✓	\$ 550
24 ± 10%	0-1	60244A	SLOT	490	0.05%	0.05%	1 mV	105-125	48-440		R		See pg 490
0-24	0-3	6224B	MPM	473	.01% + 4 mV	.01% + 2 mV	0.5	105-125 or 210-250	50-60	✓	B	✓	325
0-25	0-0.2	801C	—	491	2 mV	2 mV	0.1	105-125	55-65		R		149
0-25	0-1.5	6220B	MPM	473	.01% + 2 mV	.01% + 2 mV	0.5	105-125 or 210-250	50-400	✓	B	✓	250
28 ± 10%	0-1.5	60285A	SLOT	490	0.05%	0.05%	1 mV	105-125	48-400		R		See pg 490
0-30	0-0.15	721A	—	473	30 mV	± 15 mV	0.15	115/230 ± 10%	50-60		B		145
0-30	0-1	6206B	LAB	470-471	4 mV + 0.01%	4 mV + 0.01%	0.2	105-125 or 210-250	50-400	✓	B		169
0-36	0-0.15	6346A	MOD	488-489	3 mV or 0.02%	3 mV or 0.02%	1.0	105-125 or 210-250	48-440	✓	R		120
0-36	0-0.5	6347A	MOD	488-489	3 mV or 0.02%	3 mV or 0.02%	1.0	105-125 or 210-250	48-63	✓	R		165
0-36	0-1.5	6348A	MOD	488-489	3 mV or 0.02%	3 mV or 0.02%	1.0	105-125 or 210-250	48-63	✓	R		225
0-36	0-3	6265A	LVR	482-483	200 μV + 0.01%	200 μV + 0.01%	0.5	100-130 or 200-260	48-63	✓	R	✓	350
0-36	0-5	6266A	LVR	482-483	200 μV + 0.01%	200 μV + 0.01%	0.5	100-130 or 200-260	48-63	✓	R	✓	435
0-36	0-10	6433B	SCR-1P	485	36 mV	18 mV	36	105-125	57-63	✓	R	✓	370
0-36	0-10	6267A	LVR	482-483	200 μV + 0.01%	200 μV + 0.01%	0.5	100-130 or 200-260	48-63	✓	R	✓	525
0-36	0-25	520A	—	485	0.5% combined		360	105-125	57-63	✓	R	✓	575
0-36	0-100	6456B	SCR-3	486	10 mV + 0.2% combined		160	3* 208/230/460 ± 10%	57-63	✓	R	✓	1275
0-36	0-300	6469A	SCR-10	487	10 mV + 0.2% combined		180	3* 208/230/460 ± 10%	57-63	✓	R	✓	2300
0-40	0-0.3	6204B	LAB	470-471	4 mV + 0.01%	4 mV + 0.01%	0.2	105-125 or 210-250	50-400	✓	B		144
0-40 and 0-20	0-0.3 and 0-0.6	6205B	LAB	470-471	4 mV + 0.01%	4 mV + 0.01%	0.2	105-125 or 210-250	50-440	✓	B	✓	235
0-40	0-0.5	6102A	STB	476-477	350 μV + 0.001%	0.001%	0.04	105-125 or 210-250	48-63	✓	B		265
0-40	0-0.5	6112A	STB	476-477	350 μV + 0.001%	0.001%	0.04	105-125 or 210-250	48-63	✓	B		375
0-40	0-0.75	6200B	LAB	470-471	4 mV + 0.01%	4 mV + 0.01%	0.2	105-125 or 210-250	50-400	✓	B	✓	189
0-40	0-0.75	6202B	LAB	470-471	4 mV + 0.01%	4 mV + 0.01%	0.2	105-125 or 210-250	50-400	✓	B	✓	169
0-40	Dual 0-1.5	6255A	DPR	474-475	2 mV + 0.01%	2 mV + 0.01%	0.2	105-125 or 210-250	50-400	✓	R	✓	445
0-40	0-1.5	6289A	MPB-3	474-475	2 mV + 0.01%	2 mV + 0.01%	0.2	105-125 or 210-250	50-400	✓	B	✓	210
0-40	0-3	6290A	MPB-5	474-475	1 mV + 0.01%	1 mV + 0.01%	0.5	105-125	50-60	✓	B	✓	350
0-40	0-5	6291A	MPB-5	474-475	1 mV + 0.01%	1 mV + 0.01%	0.5	105-125	50-60	✓	B	✓	395
0-40	0-30	6268A	LVR	482-483	200 μV + 0.01%	200 μV + 0.01%	1	230 ± 10%	48-63	✓	R	✓	695
0-40	0-50	6269A	LVR	482-483	200 μV + 0.01%	200 μV + 0.01%	0.5	230 ± 10%	48-63	✓	R	✓	875
-50 to +50	0-1	6824A	PS/A	493	5 mV + 0.02%	5 mV + 0.02%	10	105-125 or 210-250	50-60	✓	B	✓	350
0-50	0-0.75	6177A	CCB	478-479	0.0015%	0.001%	0.075 mA	105-125 or 210-250	48-63	✓	B		425
0-50	0-0.75	6220B	MPM	473	4 mV + .01%	4 mV + .01%	0.5	105-125 or 210-250	50-400	✓	B	✓	259
0-50	0-1.5	6226B	MPM	473	2 mV + .01%	2 mV + .01%	0.5	105-125 or 210-250	50-60	✓	B	✓	325
0-60	0-0.5	6206B	LAB	470-471	4 mV + 0.01%	4 mV + 0.01%	0.2	105-125 or 210-250	50-400	✓	B		169
0-60	Dual 0-1	6257A	DPR	474-475	2 mV + 0.01%	2 mV + 0.01%	0.2	105-125 or 210-250	50-400	✓	R	✓	445

## CONDENSED LISTING



## DC POWER SUPPLIES

Output volts	Output amps	Model	Series	Catalog page	Load regulation (mV)	Line regulation (mV)	RMS ripple & noise (mV)	Input line voltage (V <sub>ac</sub> )	Input line frequency	Remote programming	Bench or Rack*	CV/CC**	Price
0-60	0-1	6294A	MPB-3	474-475	2 mV + 0.01%	2 mV + 0.01%	0.2	105-125 or 210-250	50-400	✓	B	✓	\$210
0-60	0-3	6296A	MPB-5	474-475	1 mV + 0.01%	1 mV + 0.01%	0.5	105-125	50-60	✓	B	✓	395
0-60	0-3	6271A	LVR	482-483	200 $\mu$ V + 0.01%	200 $\mu$ V + 0.01%	0.5	100-130 or 200-260	48-63	✓	R	✓	435
0-60	0-5	6438B	SCR-1P	485	60 mV	30 mV	120	105-125	57-63	✓	R	✓	360
0-60	0-15	6439B	SCR-1P	485	120 mV	60 mV	60	105-125	57-63	✓	R	✓	550
0-60	0-15	6274A	LVR	482-483	0.2 mV + 0.01%	0.2 mV + 0.01%	0.5	100-130	48-63	✓	R	✓	695
0-64	0-50	6459A	SCR-3	486	10 mV + 0.2% combined		160	3 $\phi$ 208/230/460 $\pm$ 10%	57-63	✓	R	✓	1275
0-64	0-150	6472A	SCR-10	487	100 mV + 0.2% combined		160	3 $\phi$ 208/230/460 $\pm$ 10%	57-63	✓	R	✓	2600
0-100	0-0.2	6106A	STB	476-477	200 $\mu$ V + 0.001%	0.001%	0.04	105-125 or 210-250	48-63	✓	B		265
0-100	0-0.2	6116A	STB	476-477	200 $\mu$ V + 0.001%	0.001%	0.04	105-125 or 210-250	48-63	✓	B		375
0-100	0-0.3	6181A	CCB	478-479	0.0015%	0.001%	0.03 mA	105-125 or 210-250	48-63	✓	B		425
0-100	0-0.75	6299A	MPB-3	474-475	2 mV + 0.01%	2 mV + 0.01%	0.2	105-125 or 210-250	50-400	✓	B	✓	225
0-100 Dual	0-0.75	6258A	DPR	474-475	2 mV + 0.01%	2 mV + 0.01%	0.2	105-125 or 210-250	50-400	✓	R	✓	445
0-110	0-100	6475A	SCR-10	487	100 mV + 0.2% combined		220	3 $\phi$ 208/230/460 $\pm$ 10%	57-63	✓	R	✓	2600
0-120	0-2.5	6443B	SCR-1P	485	120 mV	60 mV	240	105-125	57-63	✓	R	✓	360
0-160	0-0.2	6207B	LAB	470-471	2 mV + 0.02%	2 mV + 0.02%	0.5	105-125 or 210-250	48-63	✓	B	✓	194
0-160	0-0.4	6354A	MOD	488-489	2 mV + 0.005%	1 mV + 0.005%	1.0	105-125 or 210-250	48-63	✓	R	✓	259
0-220	0-50	6477A	SCR-10	487	100 mV + 0.2% combined		330	3 $\phi$ 208/230/460 $\pm$ 10%	57-63	✓	R	✓	2600
0-300	0-0.1	6186A	CCB	478-479	0.0015%	0.001%	0.01 mA	105-125 or 210-250	48-63	✓	B		425
0-300	0-35	6479A	SCR-10	487	100 mV + 0.2% combined		300	3 $\phi$ 208/230/460 $\pm$ 10%	57-63	✓	R	✓	2600
0-320	0-0.1	6209B	LAB	470-471	2 mV + 0.02%	2 mV + 0.02%	1.0	105-125 or 210-250	48-63	✓	B	✓	194
0-320	0-0.2	6357A	MOD	488-489	2 mV + 0.005%	1 mV + 0.005%	1.0	105-125 or 210-250	48-63	✓	R	✓	259
0-320	0-0.6	890A	MVR	484	10 mV or 0.007%	10 mV or 0.007%	1.0	105-125	57-63	✓	R		445
0-320	0-1.5	895A	MVR	484	10 mV or 0.007%	10 mV or 0.007%	1.0	105-125	57-63	✓	R		625
-250 to -400 0 to -900	.03-.05 0-10 $\mu$ A	715A†	-	492	1% 1%	1% 1%	7 10	115/230 $\pm$ 10%	50-60		B		365
0-500	0-0.1	711A†	-	491	1000 or 0.5%	1000 or 0.5%	1	115/230 $\pm$ 10%	50-1000		B		275
0 to +500 -300 0 to -150	0-0.2 0-0.05 0-0.005	712B†	-	491	50 50 -	$\pm$ 100 $\pm$ 100 $\pm$ 100	0.5 0.5 0.5	115 $\pm$ 10%	50-60		B		490
0-440 or 0-500 or 0-600	0-25 or 0-20 or 0-15	6483B	SCR-10	487	100 mV + 0.2% combined		500	3 $\phi$ 208/230/460 $\pm$ 10%	57-63	✓	R	✓	2600
1-600	0-1.5	6448B	SCR-1P	485	600 mV	600 mV	600 mV	105-125	57-63	✓	R	✓	550
-250 to -800 0 to -800 6.3 V (ADJ)	0-2.0	716B†	-	492	0.05% - -	0.05% 0.05% 1%	1 0.5 2	115/230 $\pm$ 10%	50-60		B		875
0-1000	0-0.2	6521A	HVR	484	20 mV or 0.005%	20 mV or 0.005%	1.0	105-125	50-70		R		750
0-1600	0-0.005	6515A	HVB	472	16 mV or 0.01%	16 mV or 0.01%	2.0	105-125	60		B		235
0-2000	0-0.1	6522A	HVR	484	20 mV or 0.002%	20 mV or 0.005%	1.0	105-125	50-70		R		750
0-3000	0-0.006	6110A	STB	476-477	100 $\mu$ V + 0.001%	0.001%	0.4	105-125	57-63		B		495
0-3000	0-0.006	6516A	HVB	472	16 mV or 0.01%	16 mV or 0.01%	4	105-125 or 210-250	57-63		B		295
0-4000	0-0.05	6525A	HVR	484	20 mV or 0.001%	20 mV or 0.005%	1.0	105-125	50-70		R		750

All Supplies: 50°C maximum ambient temperature rating. Floating output (ground either side), continuously variable output, low output impedance at all frequencies, 3-wire input, computer-quality electrolytics, 1 year warranty. No turn-on, turn-off overshoot; short-circuit-proof, all semiconductor except as noted by†.

Transistor Supplies: Glass-epoxy printed circuit board construction, fully automatic overload protection — short-circuit-proof.



Refer to "Power Supply Handbook," Application Note 90 for further information on definitions, theory, operation, and applications. AN-90 is available free of charge from your local Hewlett-Packard Field Sales Office.

**Ambient temperature.** The room temperature, or effective temperature of the environment in which the power supply is operating.

**Auto-parallel or automatic parallel operation.** A master-slave parallel connection of the outputs of two or more Hewlett-Packard supplies used for obtaining a current output greater than that obtainable from one supply. Auto-Parallel operation is characterized by one-knob control, equal current sharing, and no internal wiring changes. Normally only supplies having the same model number may be connected in Auto-Parallel; in certain cases, however, supplies of the same Series are capable of mixed Auto-Parallel operation.

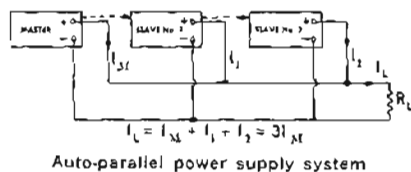

**Auto-series or automatic series operation.** A master-slave series connection of the outputs of two or more Hewlett-Packard power supplies used for obtaining a voltage greater than that obtainable from one supply. Auto-Series operation, which is permissible up to 300 volts off ground, is characterized by one-knob control, equal or proportional voltage sharing, and no internal wiring changes. Supplies of mixed model numbers may be connected in Auto-Series without restriction, provided that each slave is listed as being capable of Auto-Series operation.

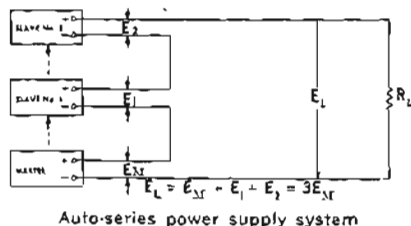

**Auto-tracking or automatic tracking operation.** A master-slave connection of two or more Hewlett-Packard power supplies each of which has one of its out-

put terminals in common with one of the output terminals of all of the other power supplies, such a connection pattern being characterized by one-knob control, proportional output voltage from all supplies, and no internal wiring changes. Useful where simultaneous turn-up, turn-down or proportional control of all power supplies in a system is required.

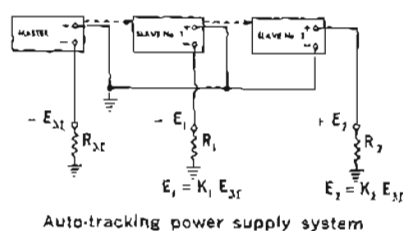

**Constant current power supply.** A regulated power supply which acts to keep its output current constant in spite of changes in load, line, or temperature. Thus, for a change in load resistance, the output current remains constant to a first approximation, while the output voltage changes by whatever amount necessary to accomplish this.

**Constant voltage power supply.** A regulated power supply which acts to keep its output voltage constant in spite of changes in load, line, or temperature. Thus, for a change in load resistance, the output voltage of this type of supply remains constant to a first approximation, while the output current changes by whatever amount necessary to accomplish this, the most common type of regulated dc power supply.

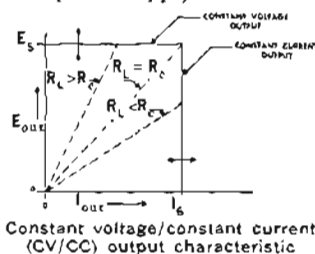

**Constant voltage/constant current (CV/CC) with automatic crossover.** A power supply which acts as a constant voltage source for comparatively large values of load resistance and as a constant current source for comparatively small values of load resistance. The automatic crossover or transition between these two modes of operation occurs at a "critical" or "crossover" value of load resistance  $R_C = E_S / I_S$  where  $E_S$  is the front panel voltage control setting and  $I_S$  is the front panel

current control setting.

**Constant voltage/current limiting (CV/CL) with automatic crossover.** The same as CV/CC operation except for a slightly poorer regulation characteristic for low values of load resistance, i.e., in the "constant current" region of operation.

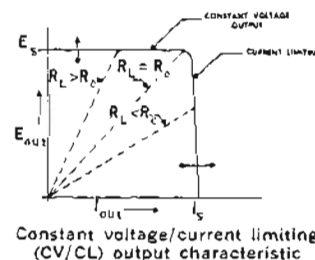

**"Crowbar" voltage protector.** A separate circuit which monitors the output of a power supply and instantaneously throws a short circuit (or "crowbar") across the output terminals of the power supply whenever a preset voltage limit is exceeded. An SCR is usually used as the "crowbar" device.

**Drift.** A term loosely used to describe the slow variations in the output of a regulated power supply due to STABILITY and/or TEMPERATURE COEFFICIENT.

**Line regulation of a constant current power supply.** The change in the static value of the dc output current resulting from a change in ac input voltage from low line (usually 105 volts) to high line (usually 125 volts) or from high line to low line.

**Line regulation of a constant voltage power supply.** The change in the static value of dc output voltage resulting from a change in ac input voltage from low line (usually 105 volts) to high line (usually 125 volts) or from high line to low line.

**Load regulation of a constant current power supply.** The change in the static value of dc output current resulting from a change in load resistance from short circuit to a value which gives maximum rated output voltage.

**Load regulation of a constant voltage power supply.** The change in the static value of dc output voltage resulting from a change in load resistance from open circuit to a value which yields maximum rated output current.

## DEFINITIONS AND OPTIONS



## DC POWER SUPPLIES

**Output impedance of a power supply.** At any given frequency of load change,  $\Delta E_{out}/\Delta I_{out}$ . Strictly speaking the definition applies only for a sinusoidal load disturbance, unless, of course, the measurement is made at zero frequency (dc). The output impedance of an ideal constant voltage power supply would be zero at all frequencies, while the output impedance for an ideal constant-current power supply would be infinite at all frequencies.

**Recovery time.** See Transient Recovery Time.

**Remote error sensing or Remote sensing.** A feature found on most HP power supplies, which, by means of two extra wires between the supply and the load, permits the power supply to achieve its optimum regulation at the load terminals rather than at the power supply output terminals, thus compensating for the IR drop present in the current carrying leads connecting the load to its power supply. The current through the sensing leads is so small that in spite of the resistance of these leads, their voltage drop is negligible.

**Remote programming.** A feature of most HP power supplies which makes possible control of the regulated output by means of a remotely varied resistance. This feature also permits control of the output of a power supply by means of a voltage input rather than by means of a control resistance.

**Ripple.** The residual ac component which is superimposed on the dc component of the output of a regulated power supply. Ripple is usually specified in terms of its RMS value.

**Stability.** Obviously a misnomer, this term refers to the instability in power supply output which occurs in the presence of constant load, constant line and constant ambient temperature for a stated period of time (usually 8 hours) following warm-up. This small output variation, which is related in part to the internal temperature rise of the power supply, is the zero frequency component of noise which must be present in any dc amplifier or regulator, even though all input, output, environmental, and control parameters are held constant.

**Temperature coefficient.** For a power supply operated at constant load and under conditions of constant input ac line voltage, the change in output voltage (for a constant voltage supply) or output current (for a constant current supply) for each degree change in the ambient temperature.

**Transient recovery time.** Sometimes referred to as *recovery time*, *transient response time*, or *response time* — loosely speaking the time required for the output voltage of a power supply to come back to within a level approximating the normal dc output following a sudden change in load current. More exactly, Transient Recovery Time is the time "X" required for output voltage recovery to within "Y" millivolts of the nominal output voltage following a "Z" amp step change in load current — where:

"Y" is specified separately for each model but is generally of the same order as the load regulation specification, the nominal output voltage is defined as the dc level half way between the static output voltage before and after the imposed load change, and "Z" is the specified load current change, normally equal to the full load current rating of the supply.

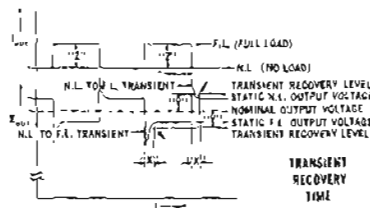

### Options

Options are mechanical and/or electrical modifications to standard instruments performed at the factory. Below is a list of all the options available on HP DC Power Supplies. To determine which options are available for a particular supply, refer to the appropriate product (pages 470-493).

#### No. Description

- 01 208  $\pm 10\%$  V ac Input, 57-63 Hz. Input is factory wired for 208 V ac.
- 02 230  $\pm 10\%$  V ac Input, 57-63 Hz. Input is factory wired for 230 V ac.
- 03 460  $\pm 10\%$  V ac Input, 57-63 Hz. Input is factory wired for 460 V ac.
- 04 Cabinet Style with Casters. Dimensions change to 17" W x 29 $\frac{3}{4}$ " H x 22 $\frac{1}{2}$ " D (43,2 x 75,6 x 57,2 cm).
- 05 50 Hz AC Input Regulation Realignment. Standard instrument will operate satisfactorily at both 60 and 50 Hz without adjustment. However, Option 05 factory realignment results in more efficient operation at 50 Hz, and is recommended for all applications which involve continuous operation from a 50 Hz ac input.

- 06 Overvoltage "Crowbar" Protector. Protects delicate loads against power supply failure or operator error. Compact, inexpensive, can be factory installed (only) at rear of power supply. Virtual short circuit (SCR crowbar) is placed across load within 10 microseconds after overvoltage margin is exceeded.

Overvoltage Margin: 1 to 4 volts, screwdriver adjust.

Power Requirement: 15 MA continuous drain from power supply being protected.

Size: Add 5 inches to depth of power supply.

Weight: Add 2 lbs. to net weight, 4 lbs. to shipping weight.

- 07 Ten-Turn Output Voltage Control. Replaces concentric coarse and fine voltage control.
- 08 Ten-Turn Output Current Control. Replaces concentric coarse and fine current control.
- 09 Ten-Turn Output Voltage And Current Controls. Same as Options 07 and 08 on same instrument.
- 10 Chassis Slides: Enables convenient access to power supply interior for maintenance. Chassis slides are attached to supply at the factory.
- 13 Three Digit Graduated Decadial Voltage Control: Includes 10-turn control replacing coarse and fine voltage control.
- 14 Three Digit Graduated Decadial Current Control: Includes 10-turn control replacing coarse and fine current control.
- 15 No 5 V and .075 A Meter Ranges: Model 6205B is available without the lower meter ranges, resulting in a \$40 price reduction from the standard model.
- 26 Rewire for 115 V Single-Phase AC Input: Supply as normally shipped is wired for 230 V ac input, and must be internally reconnected for 115 V ac operation.
- 27 Rewire for 208 V Single-Phase AC Input: Supply as normally shipped is wired for 230 V ac input, and must be internally reconnected for 208 V ac operation.
- 28 Rewire for 230 V Single-Phase AC Input: Supply as normally shipped is wired for 115 ac input, and must be internally reconnected for 230 V ac operation.

# DC POWER SUPPLIES



## LAB SERIES

Laboratory bench dc power supplies

Models 6200B-6209B

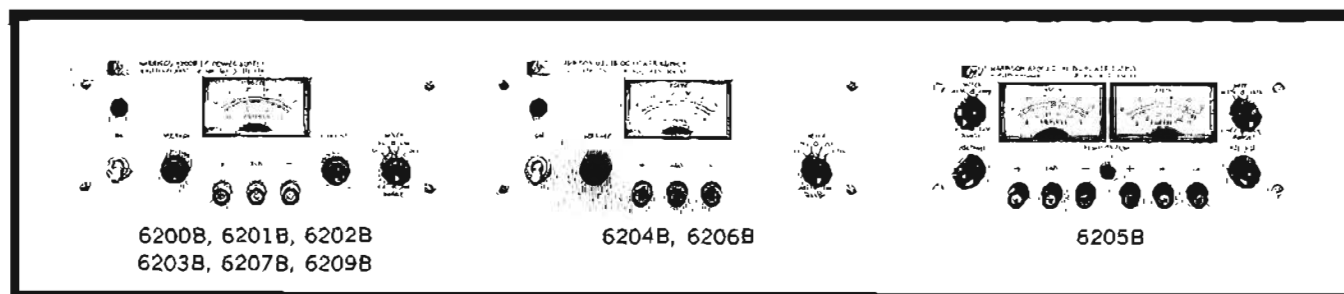

LAB Series supplies, already regarded as the industry standard for comparison because of their reliability, versatility, and performance specifications, have now been updated. The glass epoxy printed wiring board now mounts all circuit components via plated-through holes; a new package design achieves greater rack-mounting rigidity and ease in assembly. New production techniques result in improved reliability and lowered costs permitting Hewlett-Packard to manufacture these instruments at a competitive price.

All "B" version LAB Series supplies employ all-silicon circuitry. In addition, on models 6200B, 6201B, 6202B, and 6203B, special circuitry has been included to increase the down-programming speed, thus making it commensurate with the up-programming capability.

To further increase bench utility, multiple range meters have been included as standard on all models. Switching the meter range switch to the "wrong" position will result in no damage to the meter or degradation of power supply performance.

Model	6200B†		6201B†		6202B†		6203B	
CONSTANT VOLTAGE/CONSTANT CURRENT								
Output	DC Voltage	0-20 V	DUAL RANGE	0-40 V	0-20 V	0-40 V	0-7.5 V	
	DC Current	0-1.5 A		0-0.75 A	0-1.5 A	0-0.75 A	0-3 A	
Input	105-125/210-250 V ac, 50-400 Hz, 0.9 A, 70 W		105-125/210-250 V ac, 50-400 Hz, 0.8 A, 66 W		105-125/210-250 V ac, 50-400 Hz, 0.8 A, 66 W		105-125/210-250 V ac, 50-400 Hz, 0.9 A, 70 W	
Load regulation	Constant Voltage	0.01% plus 4 mV		0.01% plus 4 mV		0.01% plus 4 mV		5 mV
	Constant Current	0.03% plus 250 $\mu$ A		0.03% plus 250 $\mu$ A		0.03% plus 250 $\mu$ A		0.03% plus 250 $\mu$ A
Line regulation	Constant Voltage	0.01% plus 4 mV		0.01% plus 4 mV		0.01% plus 4 mV		3 mV
	Constant Current	0.01% plus 250 $\mu$ A		0.01% plus 250 $\mu$ A		0.01% plus 250 $\mu$ A		0.01% plus 250 $\mu$ A
Ripple and noise	Constant Voltage	200 $\mu$ V rms		200 $\mu$ V rms		200 $\mu$ V rms		200 $\mu$ V rms
	Constant Current	500 $\mu$ A rms		500 $\mu$ A rms		500 $\mu$ A rms		500 $\mu$ A rms
Remote programming	Constant Voltage*	200 ohms per volt		200 ohms per volt		200 ohms per volt		200 ohms per volt
	Constant Current†	500 ohms per amp	1000 ohms per amp	1000 ohms per amp		1000 ohms per amp		500 ohms per amp
Overload protection	Constant voltage/constant current circuit provides complete protection for the power supply for any overload condition. In addition, continuously adjustable current limiting in constant voltage operation and continuously adjustable voltage limiting in constant current operation provides optimum protection for the load device.							
Controls	Off-On Switch, Pilot Light, Concentric Coarse and Fine Voltage Control, Concentric Coarse and Fine Current Control, Concentric Meter Range and Output Range Switch.		Off-On Switch, Pilot Light, Concentric Coarse and Fine Voltage Control, Concentric Coarse and Fine Current Control, Meter Range Switch.		Off-On Switch, Pilot Light, Concentric Coarse and Fine Voltage Control, Concentric Coarse and Fine Current Control, Meter Range Switch.		Off-On Switch, Pilot Light, Concentric Coarse and Fine Voltage Control, Concentric Coarse and Fine Current Control, Meter Range Switch.	
Meter ranges	0-5 V, 0-50 V, 0-1.8 A, 0-1.8 A		0-2.4 V, 0-24 V, 0-1.8 A, 0-1.8 A		0-5 V, 0-50 V, 0-0.9 A, 0-9 A		0-9 V, 0-9 V, 0-4 A, 0-4 A	
Weight (Net/Shipping)	14/19 lbs. (6.34/8.60 kg)		14/19 lbs. (6.34/8.60 kg)		14/19 lbs. (6.34/8.60 kg)		14/19 lbs. (6.34/8.60 kg)	
Price	\$189		\$169		\$169		\$169	
Options Refer to page 469 for descriptions	06-\$95 07-\$25	08-\$25 09-\$45	13-\$60 14-\$60	28-\$10		07-\$25 08-\$25 09-\$45	13-\$60 14-\$60 28-\$10	

\*Voltage programming coefficient accuracy 100mv plus 2% of output voltage setting. † Similar Models are manufactured in Western Europe.

## LAB SERIES

### Laboratory bench dc power supplies

Models 6200B-6209B



## DC POWER SUPPLIES

### Advantages

- All-silicon design
- Multiple range meter
- Remote programming and sensing
- High-speed programming
- Auto-series, auto-parallel, auto-tracking
- Overvoltage protection "crowbar" option
- Short circuit proof
- Front and rear output terminals
- Floating output
- RFI conformance to MIL-I-6181D

### LAB Specifications

**Transient Recovery Time** — Less than 50  $\mu$ sec for output recovery to within 10 mV following a full load current change in output.

**Internal Impedance** — Less than 0.02 ohm from DC to 1 kc. Less than 0.5 ohm from 1 kc to 100 kc. Less than 3.0 ohms from 100 kc to 1 mc.

**Cooling** — Convection cooling is employed. No moving parts.

**Power Cord** — 3-wire, 5-foot power cord.

**Size** — 3½" (8.9 cm) H x 12⅝" (32 cm) D x 8½" (21.6 cm) W  
—Half rack width.

**Finish** — Light gray panel with dark gray case.

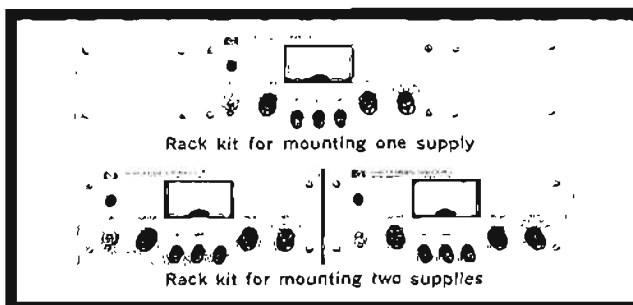

### Accessories:

Part Number	Description	Price
C05	8" black handle attached to side of 3½" H supply	\$15.00
14513A	Rack Kit for mounting one 3½" H supply	\$20.00
14523A	Rack Kit for mounting two 3½" H supplies	\$19.00

**High-Speed Programming** — Models 6200B, 6201B, 6202B, 6203B: 30v/ms when programming in either direction between 1v and maximum rated output; less than 2 ms between 0 and 1v.

**Maximum Ambient Operating Temperature** —  $\pm 50^{\circ}\text{C}$ .

6204B†			6206B			6206B			6207B		6209B	
CONSTANT VOLTAGE/CURRENT LIMITING									CV/CC			
0-20 V	DUAL RANGE	0-40 V	0-20 V	TWO DUAL RANGE OUTPUTS	0-40 V	0-30 V	DUAL RANGE	0-60 V	0-160 V	0-320 V		
0-0.6 A		0-0.3 A	0-0.6 A		0-0.3 A	0-1 A		0-0.5 A	0-0.2 A	0-0.1 A		
105-125/210-250 V ac, 50-400 Hz, 0.4 A, 24 W			105-125/210-250 V ac, 50-400 Hz, 0.5 A, 50 W			105-125/210-250 V ac, 50-400 Hz, 1.0 A, 66 W			105-125/210-250 V ac, 48-63 Hz, 1.0 A, 60 W		105-125/210-250 V ac, 48-63 Hz, 1.0 A, 60 W	
0.01% plus 4 mV			0.01% plus 4 mV			0.01% plus 4 mV			0.02% plus 2 mV		0.02% plus 2 mV	
-----			-----			-----			200 $\mu$ A		200 $\mu$ A	
0.01% plus 4 mV			0.01% plus 4 mV			0.01% plus 4 mV			0.02% plus 2 mV		0.02% plus 2 mV	
-----			-----			-----			200 $\mu$ A		200 $\mu$ A	
200 $\mu$ V rms			200 $\mu$ V rms			200 $\mu$ V rms			500 $\mu$ V rms		1 mV rms	
-----			-----			-----			200 $\mu$ A rms		200 $\mu$ A rms	
200 ohms per volt			200 ohms per volt			300 ohms per volt			300 ohms per volt		300 ohms per volt	
-----			-----			-----			75 K ohms per amp		150 K ohms per amp	
Fixed current limit provides complete protection for any overload condition. This limit is set at approximately 700 mA for the 20 volt range and 350 mA for the 40 volt range.			Fixed current limit provides complete protection for any overload condition. This limit is set at approximately 700 mA for the 20 volt range and 350 mA for the 40 volt range.			Fixed current limit provides complete protection for any overload condition. This limit is set for approximately 1.2 A for the 30 volt range and 600 mA for the 60 volt range.			Same as 6200B			
Off-On Switch, Pilot Light, Concentric Coarse and Fine Voltage Control, Concentric Meter Range and Output Range Switch.			Combined Pilot Light and On-Off Button, Two Concentric Coarse and Fine Voltage Controls, Two Concentric Meter Range and Output Range Switches.			Off-On Switch, Pilot Light, Concentric Coarse and Fine Voltage Control, Concentric Meter Range and Output Range Switch.			Off-On Switch, Pilot Light, 10-turn Voltage Control, Concentric Coarse and Fine Current Control, Meter Range Switch.		Off-On Switch, Pilot Light, 10-turn Voltage Control, Concentric Coarse and Fine Current Control, Meter Range Switch.	
0-5 V, 0-50 V, 0-0.075 A, 0-0.75 A			0-5 V, 0-50 V, 0-0.075A, 0-0.75A			0-7 V, 0-70 V, 0-0.12 A, 0-1.2 A			0-20 V, 0-200 V, 0-24 mA, 0-240 mA		0-40 V, 0-400 V, 0-12 mA, 0-120 mA	
10/13 lbs. (4.53/5.89 kg)			10/13 lbs. (4.53/5.89 kg)			12/17 lbs. (5.43/7.70 kg)			13/18 lbs. (5.89/8.15 kg)		13/18 lbs. (5.89/8.15 kg)	
\$144			\$235			\$169			\$194		\$194	
06—\$95 13—\$60 07—\$25 28—\$10			06—\$190 13—\$140 07—\$50 28—\$10 15—Deduct \$40			06—\$95 13—\$60 07—\$25 28—\$10			05—\$10—No charge if ordered with option 28. 06—\$95 08—\$25		13—\$35 28—\$10 14—\$60	

†Current programming coefficient accuracy 6% of current rating plus 10% of output current setting.

# DC POWER SUPPLIES



## HVB SERIES

High voltage bench supplies  
Models 6515A, 6516A

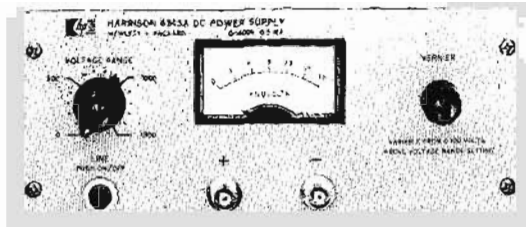

6515A

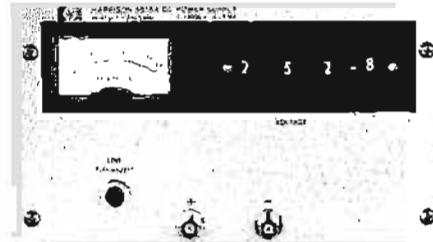

6516A

### Advantages

- All-silicon semiconductor circuitry—no tubes
- Short-circuit-proof—current limit circuit
- Low output impedance at all frequencies
- 100  $\mu$ sec load transient recovery
- No overshoot for turn-on, turn-off, or power removal
- Floating output—can be used as positive or negative source
- Adjustable to zero volts for curve plotting and gradual turn-on of delicate loads

### Accessories

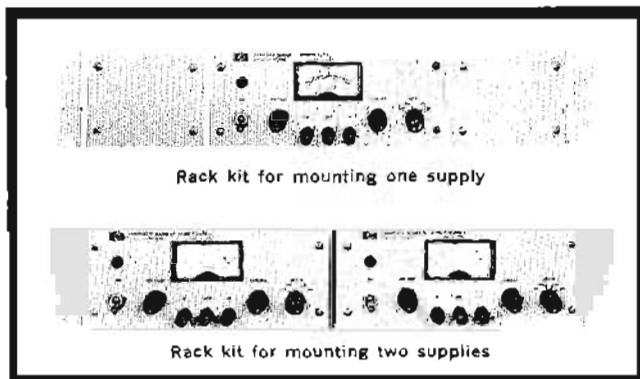

Rack kit for mounting one supply

Rack kit for mounting two supplies

### Specifications

- Output:** 6515A—0-1600 V dc, 0.5 milliamps. 6516A—0-3000 V dc, 0.6 milliamps.
- Input:** 6515A—105-125 V ac, single phase,  $60 \pm 0.3$  Hz (cps), 162 mA, 19 watts max. 6516A—105-125 V ac, single phase, 57-63 Hz, 1.0 amp, 40 watts max.
- Load regulation:** Less than 0.01% or 16 millivolts (whichever is greater).
- Line regulation:** Less than 0.01% or 16 millivolts (whichever is greater).
- Ripple and noise:** Less than 2 mV rms. Less than 5 mV peak-to-peak.
- Temperature coefficient:** Less than 0.02% plus 2 millivolts/ $^{\circ}$ C.
- Stability:** The total drift for 8 hours (after 30 minutes warmup) at a constant ambient is less than 0.05% plus 5 millivolts.
- Temperature rating:** Operating: 0 to  $50^{\circ}$ C. Storage:  $-20$  to  $+85^{\circ}$ C.
- Output impedance:**  
Less than 32 ohms from dc to 30 Hz (cps).  
Less than 8 ohms from 30 Hz to 100 kHz.  
Less than 2 ohms from 100 kHz to 1 MHz.
- Controls:** 6515A—Sixteen position rotary switch adjusts the output voltage in 100-volt steps; a 10-turn vernier permits continuous adjustment with a 100 mV resolution over any 100-volt span. 6516A—Four-digit front panel voltage programmer with 1-volt resolution.
- Meters:** A 0-1800 Volt voltmeter is included on the front panel of the 6515A. The 6516A has a 0-3500 Volt voltmeter.
- Size:** 6515A— $8\frac{1}{2}$ " (21.6 cm) W x  $3\frac{1}{2}$ " (8.9 cm) H x  $11\text{-}13\frac{1}{16}$ " (3 cm) D. 6516A— $8\frac{1}{2}$ " (21.6 cm) W x  $5\frac{1}{4}$ " (12.8 cm) H x 14" (35.6 cm) D.
- Weight:** 6515A—12 pounds (5.44 kg) net, 15 pounds (6.8 kg) shipping.  
6516A—17 pounds (7.71 kg) net, 20 pounds (9.07 kg) shipping.
- Finish:** Light gray front panel with dark gray case.
- Power cord:** A 3-wire 5-foot (1.52 m) power cord is provided with each unit.
- Price:** 6515A—\$235.00, 6516A—\$295.00.

### Options:

05. 50 Hz ac input: Supply as normally shipped is wired for 60 Hz operation; Option 05 includes internal rewiring and re-testing. Available on Model 6516A only. Add: \$50.
13. Calibrated Decadal. This calibrated 10-turn potentiometer replaces the front panel 10-turn vernier to provide resetability within 0.1%. Add \$35.00. Available in Model 6515A only.
28. Rewire for 230 V, single phase ac input. Unit as normally shipped is wired for 115 V ac input and must be internally reconnected. Available on Model 6516A only. Add \$50.

PART NO.	DESCRIPTION	PRICE
C05	8" black handle attached to side of $3\frac{1}{2}$ " H supply. Standard on $5\frac{1}{4}$ " H supplies	\$15.00
14513A	Rack kit for mounting one $3\frac{1}{2}$ " H supply	\$20.00
14515A	Rack kit for mounting one $5\frac{1}{4}$ " H supply	\$23.00
14523A	Rack kit for mounting two $3\frac{1}{2}$ " H supplies	\$10.00
14525A	Rack kit for mounting two $5\frac{1}{4}$ " H supplies	\$12.00



# MPM SERIES & MODEL 721A

Medium power modular dc supplies  
Models 6220B-6226B and 721A



## DC POWER SUPPLIES

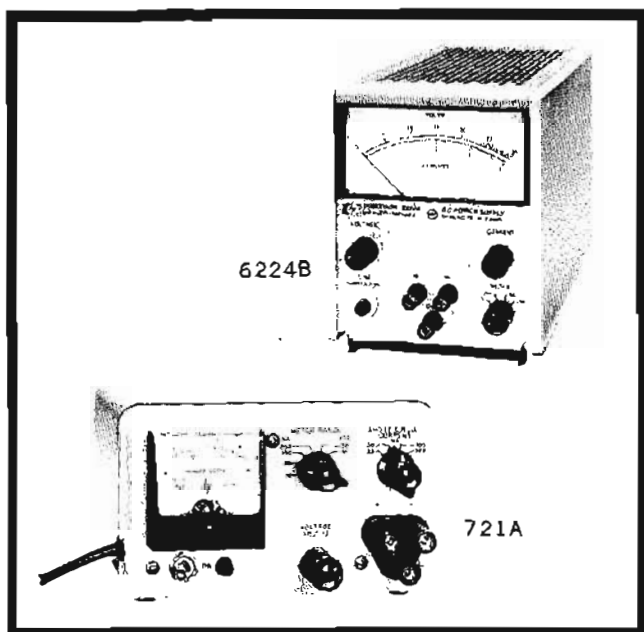

The MPM Series consists of compact Constant Voltage/Constant Current dc power supplies suitable for either bench or rack operation. They are packaged in one-third rack width modules for use in the modular enclosure system, described on pages 568 and 569. MPM supplies are designed to satisfy the need for a general purpose and reliable source of power for engineers experimenting with transistor circuit design.

Models 6224B and 6226B possess all of the advantages of the preceding "A" versions of these models plus the following improvements:

- Increased output voltage.
- Ten-turn voltage and current controls for better output settable.
- Multiple range meter for increased bench utility.
- Special circuitry for faster programming.
- All silicon semiconductors for greater reliability.

In addition a dual range supply, Model 6220B has been added to the series. This supply can be used as a 0-25 volt source at 0-1.5 amps or a 0-50 volt source at 0-0.75 amps.

Model 721A is designed to produce regulated dc voltages for transistor investigation. An outstanding feature of this supply is a circuit which limits the output current to a nominal value determined by a front-panel switch. In case of accidental overloads, this feature can prevent costly damage to transistors under test.

### Specifications

Model		6220B	6224B	6226B	721A
Output	DC voltage	0-25 V Dual range	0-50 V	0-24 V	0-50 V
	DC current	0-1.5 A	0-0.75 A	0-3 A	0-0.15 A
Input: 105-125/210-250 V ac		50-400 Hz		50-60 Hz 1.8 A, 164 W	50-60 Hz 1.8 A, 164 W
Load regulation: the constant voltage load regulation is given for a load current change equal to the current rating of the supply. The constant current load regulation is given for a load voltage change equal to the voltage rating of the supply.	CV	0.01% plus 2 mV	0.01% plus 4 mV	0.01% plus 2 mV	0.3% or 30 mV
	CC	0.03% plus 250 $\mu$ A	0.01% plus 250 $\mu$ A	0.01% plus 250 $\mu$ A	—
Line regulation: for a change in line voltage from 105 to 125 (or 125 to 105) at any output voltage and current within rating.	CV	0.01% plus 2 mV	0.01% plus 2 mV	0.01% plus 2 mV	0.3% plus 15 mV
	CC	0.01% plus 250 $\mu$ A	0.01% plus 250 $\mu$ A	0.01% plus 250 $\mu$ A	—
Ripple and noise: at any line voltage and under any load condition within rating.	CV	500 $\mu$ V rms/1 mV p-p (dc to 20 MHz)			150 $\mu$ V rms
	CC	500 $\mu$ A rms/1 mA p-p (dc to 20 MHz)			—
Temperature coefficient: output change per degree centigrade change in ambient following 30 minutes warm-up.	CV	0.02% plus 1 mV	0.02% plus 500 $\mu$ V	0.02% plus 500 $\mu$ V	—
	CC	0.02% plus 1 mA	0.02% plus 0.5 mA	0.02% plus 1.5 mA	0.02% plus 0.8 mA
Stability: under constant ambient conditions, total drift for 8 hours following 30 minutes warm-up.	CV	0.1% plus 5 mV	0.1% plus 2.5 mV	0.1% plus 2.5 mV	—
	CC	0.1% plus 5 mA	0.1% plus 2.5 mA	0.1% plus 4 mA	—
Remote programming: all programming terminals are located on rear barrier strips.	CV	200 ohms per volt	200 ohms per volt	200 ohms per volt	—
	CC	300 ohms per amp 1000 ohms per amp	500 ohms per amp	500 ohms per amp	—
Meter ranges:		0-6 V, 0-60 V, 0-0.18 A, 0-1.8 A	0-3 V, 0-30 V, 0-0.4 A, 0-4 A	0-6 V, 0-60 V, 0-0.18 A, 0-1.8 A	10, 30, 100, 300 mA, 10, 30 V dc
Weight: (net/shipping)	lbs. kg	—	16/19 7.25/8.6	16/19 7.25/8.6	4/7 1.81/3.17
Price:		\$250	\$325	\$325	\$145
Options: refer to page 469 for description			13—\$35 14—\$35 28—\$10		28—\$10

CV = Constant Voltage CC = Constant Current

#### Output impedance:

DC to 100 Hz — less than 0.001 ohm, 100 Hz to 1 kHz — less than 0.01 ohm, 1 kHz to 100 kHz — less than 0.2 ohm, 100 kHz to 1 MHz — less than 2 ohms.

**Transient recovery time — MPM Series:** less than 50  $\mu$ seconds is required for output voltage recovery in constant voltage operation to within 10 millivolts of the nominal output voltage following a change in output current equal to the current rating of the supply. The nominal output voltage is defined as the mean between the no load and full load voltages.

**Temperature ratings:** operating: 0-50°C (consult factory for de-

rating information for operation between 50°C and 71°C); storage: -20°C to +85°C.

**Controls:** MPM Series — Ten-turn output voltage and current controls permit continuous adjustment over entire output span. Switch selects front panel meter voltage or current scale.

Model 721A — Six-position rotary switch selects current or voltage meter range. Four-position rotary switch selects maximum output current.

**Finish:** light gray panel with dark gray case.

**Size:** MPM Series: 6 $\frac{1}{4}$ " H x 5 $\frac{1}{8}$ " W x 11" D (15.9 cm H x 13 cm W x 28 cm D); Model 721A: 4 $\frac{3}{8}$ " H x 7" W x 5 $\frac{1}{4}$ " D (11.2 cm H x 17.8 cm W x 13.3 cm D).

# DC POWER SUPPLIES



## MPB-3 & MPB-5; DPR SERIES

Medium power bench; dual power rack supplies  
Models 6281A-6299A; 6251A-6258A

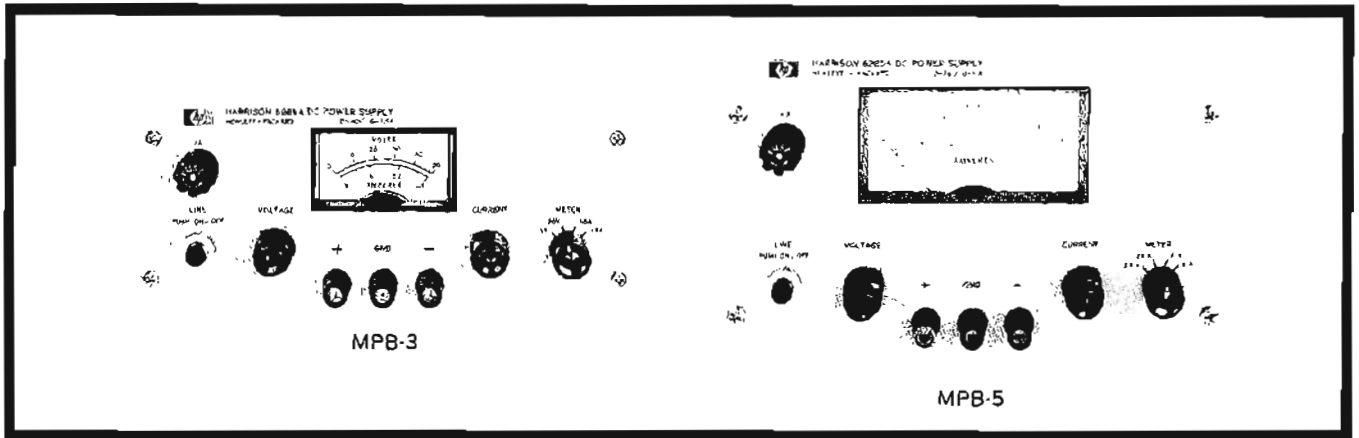

The MPB-3 and MPB-5 Series of dc power supplies are highly regulated, medium power, Constant Voltage/Constant Current bench models. All include multiple range meters and provision for Remote Sensing, Remote Programming, Auto-Series, Auto-Parallel, and Auto-Tracking operation.

The DPR Series includes five different models, each containing two identical MPB-3 supplies mounted in a full rack-width chassis. All DPR features and specifications are identical to the MPB-3 with the exceptions listed on the following page.

### Advantages:

- Short circuit proof
- Constant voltage/constant current operation with automatic crossover
- Multiple range meters
- Floating output
- All silicon circuitry
- Front and rear output terminals
- No overshoot on turn-on, turn-off, or power removal
- Easily rack mounted
- Overvoltage protection "crowbar" option
- Auto-series, auto-parallel, auto-tracking

### MPB-5 Specifications

Model		6282A	6286A	6286A	6290A	6291A	6298A
Output	DC Voltage	0-10V	0-20V	0-20V	0-40V	0-40V	0-60V
	DC Current	0-10A	0-5A	0-10A	0-3A	0-5A	0-3A
Input: 105-125 VAC, 50-60 Hz		3.5A, 200W	3.5A, 160W	5.5A, 320W	3.5A, 170W	5.5A, 280W	4.5A, 250W
*Load regulation: The Constant Voltage Load Regulation specification is given for a load current change equal to the current rating of the supply. The Constant Current Load Regulation specification is given for a load voltage change equal to the voltage rating of the supply.	C V	0.01% plus 1 mV	0.01% plus 1 mV	0.01% plus 1 mV	0.01% plus 1 mV	0.01% plus 1 mV	0.01% plus 1 mV
	C C	0.05% plus 1 mA	0.05% plus 1 mA	0.05% plus 1 mA	0.05% plus 1 mA	0.05% plus 1 mA	0.05% plus 1 mA
Line regulation: For a change in line voltage from 105 to 125 (or 125 to 105) at any output voltage and current within rating.	C V	0.01% plus 1 mV	0.01% plus 1 mV	0.01% plus 1 mV	0.01% plus 1 mV	0.01% plus 1 mV	0.01% plus 1 mV
	C C	0.05% plus 1 mA	0.05% plus 1 mA	0.05% plus 1 mA	0.05% plus 1 mA	0.05% plus 1 mA	0.05% plus 1 mA
Ripple and noise: At any line voltage and under any load condition within rating.	C V	500 $\mu$ V RMS	500 $\mu$ V RMS	500 $\mu$ V RMS	500 $\mu$ V RMS	500 $\mu$ V RMS	500 $\mu$ V RMS
	C C	5 mA RMS	3 mA RMS	5 mA RMS	3 mA RMS	3 mA RMS	3 mA RMS
Remote programming: All Programming terminals are located on rear barrier strips.	C V	200 ohms per volt	200 ohms per volt	200 ohms per volt	200 ohms per volt	200 ohms per volt	300 ohms per volt
	C C	100 ohms per amp	200 ohms per amp	100 ohms per amp	500 ohms per amp	200 ohms per amp	500 ohms per amp
Meter ranges:		0-1.2 V, 0-12 V, 0-1.2 A, 0-12 A	0-2.4 V, 0-24 V, 0-6 A, 0-6 A	0-2.4 V, 0-24 V, 0-1.2 A, 0-12 A	0-5 V, 0-50 V, 0-4 A, 0-4 A	0-5 V, 0-50 V, 0-6 A, 0-6 A	0-7 V, 0-70 V, 0-4 A, 0-4 A
Weight: (Net/Shipping)	lbs	25/32	25/32	30/40	26/33	30/40	29/38
	kg	11,3/14,5	11,3/14,5	13,6/14,1	11,8/15,0	13,6/14,1	13,1/12,7
Price		\$350	\$350	\$395	\$350	\$395	\$395
Options:		06-\$125	06-\$95	06-\$125	06-\$95	06-\$95	06-\$95
Refer to page 469 for description		05-\$10 09-\$45	No charge if ordered with Option 28 13-\$60	07-\$25 14-\$60	07-\$25 28-\$50	08-\$25	

\*CV load regulation given for rear terminals only. At front terminals CV load regulation is 0.5 mv per amp greater due to front terminal resistance.

# MPB-3 & MPB-5; DPR SERIES

Medium power bench; dual power rack supplies  
Models 6281A-6299A; 6251A-6258A



**Output impedance:**

- DC to 100 cps — less than 0.001 ohm
- 100 cps to 1 Kc — less than 0.01 ohm
- 1 Kc to 100 Kc — less than 0.2 ohm
- 100 Kc to 1 megacycle — less than 2 ohms

**Controls:** Concentric coarse and fine output voltage and current controls permit continuous adjustment over entire output span. Models 6258A and 6299A incorporate a 10-turn front panel voltage control in lieu of the concentric coarse and fine voltage controls. Switch selects front panel meter voltage or current scale.

**Finish:** Light gray panel with dark gray case.

**Accessories:** Same as HVB Series. Refer to page 00.

**Transient recovery time:** Less than 50  $\mu$ seconds is required for output voltage recovery in constant voltage operation to

within 15 millivolts of the nominal output voltage following a change in output current equal to the current rating of the supply or 5 amperes, whichever is smaller. The nominal output voltage is defined as the mean between the no load and full load voltages.

**Temperature ratings:**

- Operating: 0-50°C (consult factory for derating information for operation between 50°C and 71°C)
- Storage — 20°C to +85°C

**Size:**

- MPB-3 — 3½" H x 8½" W x 14½" D  
— 8.9 cm H x 21.8 cm W x 36.8 cm D
- MPB-5 — 5¼" H x 8½" W x 16" D  
— 13.3 cm H x 21.8 cm W x 40.7 cm D
- DPR — 3½" H x 14½" D x 19" W  
— 8.9 cm H x 36.8 cm D x 48.3 cm W

Specifications		MPB-3 6281A	DPR 6251A	MPB-3 6284A	DPR 6253A	MPB-3 6289A	DPR 6266A	MPB-3 6294A	DPR 6257A	MPB-3 6299A	DPR 6258A	
Output	DC Voltage	0-7.5V		0-20V		0-40V		0-60V		0-100V		
	DC Current	0-5A		0-3A		0-1.5A		0-1A		0-750 mA		
Input: 105-125/210-250 VAC, 50-400 Hz		1.3 A 118 W	2.6 A 236 W	1.5 A 128 W	3 A 256 W	1.3 A 110 W	2.6 A 220 W	1.3 A 114 W	2.6 A 228 W	1.5 A 135 W	3 A 270 W	
*Load regulation: The Constant Voltage Load Regulation is given for a load current change equal to the current rating of the supply. The Constant Current Load regulation is given for a load voltage change equal to the voltage rating of the supply.	C V	5 mV		0.01% plus 4 mV		0.01% plus 2 mV		0.01% plus 2 mV		0.01% plus 2 mV		
	C C	0.01% plus 250 $\mu$ A		0.01% plus 250 $\mu$ A		0.01% plus 250 $\mu$ A		0.01% plus 250 $\mu$ A		0.01% plus 250 $\mu$ A		
Line regulation: For a change in line voltage from 105 to 125 (or 125 to 105) at any output voltage and current within rating.	C V	0.01% plus 2 mV		0.01% plus 2 mV		0.01% plus 2 mV		0.01% plus 2 mV		0.01% plus 2 mV		
	C C	0.01% plus 250 $\mu$ A		0.01% plus 250 $\mu$ A		0.01% plus 250 $\mu$ A		0.01% plus 250 $\mu$ A		0.01% plus 250 $\mu$ A		
Ripple and noise: At any line voltage and under any load condition within rating.	C V	200 $\mu$ V RMS		200 $\mu$ V RMS		200 $\mu$ V RMS		200 $\mu$ V RMS		200 $\mu$ V RMS		
	C C	4 mA RMS		2 mA RMS		500 $\mu$ A RMS		500 $\mu$ A RMS		500 $\mu$ A RMS		
Remote programming: All Programming terminals are located on rear barrier strips.	C V	200 ohms per volt		200 ohms per volt		200 ohms per volt		300 ohms per volt		300 ohms per volt		
	C C	200 ohms per amp		500 ohms per amp		500 ohms per amp		1000 ohms per amp		1000 ohms per amp		
Meter ranges		0-9 V, 0-9 V, 0-6 A, 0-6 A		0-2.4 V, 0-24 V, 0-4 A, 0-4 A		0-5 V, 0-50 V, 0-18 A, 0-1.8 A		0-7 V, 0-70 V, 0-12 A, 0-1.2 A		0-12 V, 0-120 V, 0-1 A, 0-1 A		
Weight: (Net/Shipping)	lbs. kg	14/19 6,4/8,6	28/35 12,7/15,8	14/19 6,4/8,6	28/35 12,7/15,8	14/19 6,4/8,6	28/35 12,7/15,8	14/19 6,4/8,6	28/35 12,7/15,8	15/20 6,8/9,1	30/40 13,6/18,1	
Price		\$210	\$445	\$210	\$445	\$210	\$445	\$210	\$445	\$225	\$445	
Options:		06	—	—	\$95	\$190	\$95	\$190	\$95	\$190	\$95	\$250
Refer to page 469 for details		MPB-3	07—\$25	08—\$25	09—\$45	13—\$60	14—\$60	28—\$10				
		DPR	07—\$50	08—\$50	09—\$90	10—\$125	13—\$120	14—\$120	28—\$10			

CC indicates constant current.

CV indicates constant voltage.

# DC POWER SUPPLIES



## STB SERIES

High stability laboratory supplies  
Models 6101A - 6116A

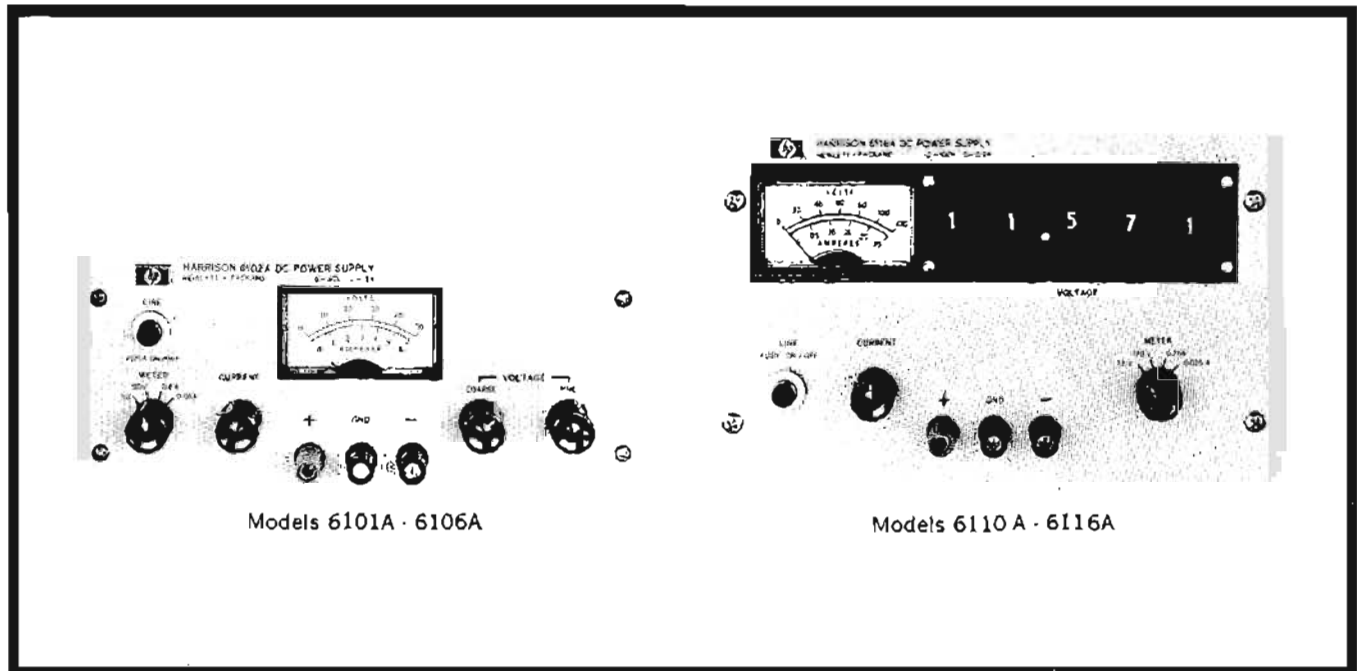

Models 6101A - 6106A

Models 6110A - 6116A

Model	6101A	6102A	6106A	6110A	6111A	6112A	6113A	6116A
DC output	0-20V 0-1A	0-40V 0-500mA	0-100V 0-200mA	0-3000V 0-5mA	0-20V 0-1A	0-40V 0-500mA	0-10V 0-2A	0-100V 0-200mA
Load regulation: For full rated output current change	Front terminals	0.001% (10ppm) plus 600 $\mu$ V	0.001% (10ppm) plus 350 $\mu$ V	0.001% (10ppm) plus 200 $\mu$ V	0.001% (10ppm) plus 100 $\mu$ V	0.001% (10ppm) plus 600 $\mu$ V	0.001% (10ppm) plus 350 $\mu$ V	0.001% (10ppm) plus 200 $\mu$ V
	Rear terminals	0.001% (10ppm) + 100 $\mu$ V			Same as 6101A	0.001% (10ppm) + 100 $\mu$ V		
Line regulation: For line input change from 105-125/210-250	0.001% (10ppm)		0.001% (10ppm)			0.001% (10ppm)		
Ripple and noise	40 $\mu$ V RMS 100 $\mu$ V P-P		40 $\mu$ V RMS 100 $\mu$ V P-P	400 $\mu$ V RMS 1 mV P-P	40 $\mu$ V RMS 100 $\mu$ V P-P	40 $\mu$ V RMS 100 $\mu$ V P-P		
Temperature coefficient: Output voltage change per $^{\circ}$ C after 30 minute warm-up.	Front panel control	0.005% (50ppm) plus 30 $\mu$ V	0.005% (50ppm) plus 50 $\mu$ V	0.005% (50ppm) plus 100 $\mu$ V	0.001% (10ppm) plus 50 $\mu$ V	0.001% (10ppm) plus 10 $\mu$ V	0.001% (10ppm) + 10 $\mu$ V	
	Remote programming	0.001% (10ppm) plus 10 $\mu$ V	0.001% (10ppm) plus 10 $\mu$ V	0.001% (10ppm) plus 50 $\mu$ V	—			
Stability: Total drift after 30 minute warm-up and with 3 $^{\circ}$ C ambient variation.	Front panel control	For 8 hrs. 0.01% + 300 $\mu$ V	For 8 hrs. 0.01% + 500 $\mu$ V	For 8 hrs. 0.01% + 1 mV	For 8 hrs. 0.01% + 500 $\mu$ V For 1 month 0.012% + 600 $\mu$ V	For 8 hrs. 0.01% + 100 $\mu$ V For 1 month 0.012% + 120 $\mu$ V	For 8 hrs. 0.01% + 100 $\mu$ V For 1 month 0.012% + 120 $\mu$ V	
	Remote programming	For 8 hrs. — 0.01% + 100 $\mu$ V For 1 month — 0.012% + 120 $\mu$ V			—	—	—	
Output impedance	DC — 100 Hz; <0.002 $\Omega$ 100 Hz — 1 kHz; <0.02 $\Omega$ 1 kHz — 100 kHz; <0.5 $\Omega$ 100 kHz — 1 MHz; <3 $\Omega$			At 3000 V DC — 1000 Hz; <50 $\Omega$ At 3 V DC — 100 Hz; <0.05 $\Omega$	Same as Model 6101A	DC — 100 Hz; <0.002 $\Omega$ 100 Hz — 1 kHz; <0.02 $\Omega$ 1 kHz — 100 kHz; <0.5 $\Omega$ 100 kHz — 1 MHz; <3 $\Omega$		
Remote programming: All programming terminals are located on rear barrier strip	Coefficient — 1000 ohms per volt Accuracy — 0.1% plus 1 mV Resettability — 0.01% + 200 $\mu$ V			—	Same as Model 6101A	Coefficient — 1000 ohms per volt Accuracy — 0.1% plus 1 mV Resettability — 0.01% + 200 $\mu$ V		
Meters ranges Single meter with switch to select scale	0-2.5V/0-25V 0-120mA/0-1.2A	0-5V/0-50V 0-60mA/0-600mA	0-12V/0-120V 0-25mA/0-250mA	0-3500V 0-7mA	0-2.5V/0-25V 0-120mA/0-1.2A	0-5V/0-50V 0-60mA/0-600mA	0-1.2V/0-12V 0-250mA/0-2.5A	0-12V/0-120V 0-25mA/0-250mA
Size	Inches	8 $\frac{1}{2}$ W $\times$ 3 $\frac{1}{2}$ H $\times$ 12 $\frac{1}{2}$ D			8 $\frac{1}{4}$ W $\times$ 5 $\frac{1}{4}$ H $\times$ 16D	8 $\frac{1}{2}$ W $\times$ 5 $\frac{1}{4}$ H $\times$ 12 $\frac{1}{2}$ D	8 $\frac{1}{2}$ W $\times$ 5 $\frac{1}{2}$ H $\times$ 12 $\frac{1}{2}$ D	
	Centimeters	21.6W $\times$ 8.9H $\times$ 32D			21.6W $\times$ 14H $\times$ 40.6D	21.6W $\times$ 14H $\times$ 32D	21.6W $\times$ 14H $\times$ 32D	
Weight: Net/Shipping	Pounds	10/13	10/13	10/13	19/23	11/15	11/15	11/15
	Kilograms	4.5/5.9	4.5/5.9	4.5/5.9	7.7/10.4	5.0/6.8	5.0/6.8	5.0/6.8
Price		\$265	\$265	\$265	\$495	\$375	\$375	\$375
Options: Refer to p. 469 for description.		06 — \$95 28 — \$10	06 — \$95 28 — \$10	06 — \$95 28 — \$10	*05 — \$50 28 — \$50	06 — \$95 28 — \$10	06 — \$95 28 — \$10	06 — \$95 28 — \$10

\*No charge if ordered with option 28

**STB SERIES**  
High stability laboratory supplies  
Models 6101A - 6116A



**DC POWER SUPPLIES**

**Advantages**

- Low output drift and temperature coefficient.
- Low output ripple
- Low output impedance
- High accuracy remote programming (except 6110A)
- Remote error sensing (except 6110A)
- No overshoot on turn-on, turn-off, or power removal
- Output continuously adjustable to zero volts
- High output voltage resolution — ten-turn coarse and one-turn fine control (6101A, 6102A and 6106A)
- In-line 5-digit thumb-wheel voltage programmer (6110A, 6111A, 6112A, 6113A, 6116A)
- All silicon design
- Positive or negative output
- Short circuit proof
- Continuously variable current limit control
- Output voltage and current metering
- Easily rack mounted for systems applications
- Auto-series and auto-tracking operation
- Multiple range meter
- Resettability — 0.01% + 200  $\mu$ V

**Description**

The STB Series of high stability dc bench supplies has been designed for those applications requiring performance an order of magnitude better than well-regulated laboratory supplies. The performance advantages of the STB Series exist with regard to virtually every important aspect of power supply performance — ripple, stability, temperature coefficient, output resolution, programming accuracy, load and line regulation.

The all-silicon circuit uses as its reference element a temperature-compensated zener diode having a temperature coefficient of 20 ppm/ $^{\circ}$ C. A high gain feedback amplifier employing a "diff-amp" (matched silicon differential amplifier package) monitors and controls the output voltage. Critical components, including the zener reference diode and low level portions of the feedback amplifier, are enclosed in an oven which is temperature-controlled entirely with solid-state components — no moving parts to wear out.

Models 6111A, 6112A, 6113A, and 6116A are similar to models 6101A, 6102A and 6106A except for the built-in 5-digit thumb-wheel voltage programmer.

Model 6110A is a high-voltage high-stability supply that is all silicon (no tubes) and also can provide a positive or negative output. The 6110A is ideally suited for high-voltage photomultipliers requiring an exceptionally stable power source. It can also be used as a 0-3000 volt calibrator.

**Specifications**

**AC input:** Model 6110A — 105-125 Vac, 57-63 Hz, 1A, 50 W. Other Models — 105-125/210-250 Vac, 48-63 Hz, 0.5A, 52W.

**Temperature ranges:** operating: 0 to 50 $^{\circ}$ C.  
storage: -20 $^{\circ}$ C to +85 $^{\circ}$ C.

**Transient recovery time:** less than 50  $\mu$ seconds is required for output voltage to recover to within 10 millivolts of the nominal output voltage following a full load change in output current.

Less than 100  $\mu$ seconds is required for output voltage recovery to within the load regulation specification.

The nominal output voltage is defined as the means between the no load and full load voltage.

**Controls:** 6101A, 6102A & 6106A—A 10 turn pot permits continuous adjustment of the output voltage over its entire range. A single-turn pot allows fine trimming of the output voltage; resolution is 100  $\mu$ V + 0.002% of the output voltage. A single-turn front-panel pot permits the current limit setting to be varied continuously from zero to a value slightly in excess of the full current rating.

6110A, 6111A, 6112A, 6113A & 6116A—An in-line 5-digit (thumb-wheel) voltage programmer permits control of the output voltage with an accuracy of 0.1% + 1 mV (6110A is 0.1% + 100 mV and 6113A is 0.1% + 10  $\mu$ V) of the output voltage. Resolution is 100  $\mu$ V (except 6110A, which is 10 mV). The 6111A, 6112A, 6113A & 6116A have a single-turn front panel pot that permits the current limit setting to be varied continuously from zero to a value slightly in excess of the full current rating. The 6110A has a fixed current limit built-in to the supply.

**Overload protection:** an all electronic, continuously acting current limit protects the power supply for all overloads regardless of how long imposed, including a direct short circuit across the output terminals.

**Output terminals:** The dc output of the supply is floating; thus, the supply can be used as either a positive or negative source. Terminals for +OUT, -OUT, and GND are provided on both the front and back of the supply (except 6110A which has front terminals only). In addition, the rear barrier strip includes terminals for remote programming, remote sensing, Auto-Series, and Auto-Tracking operation (except 6110A).

**Cooling:** convection cooling is employed. The supply has no moving parts.

**Finish:** light gray front panel with dark gray case.

**Power cord:** a 3-wire 5-foot power cord is provided with each unit.

**Accessories:** same as HVB Series. Refer to page 472.

**DC POWER SUPPLIES****CCB SERIES**

Constant current bench supplies

Models 6177A—6186A

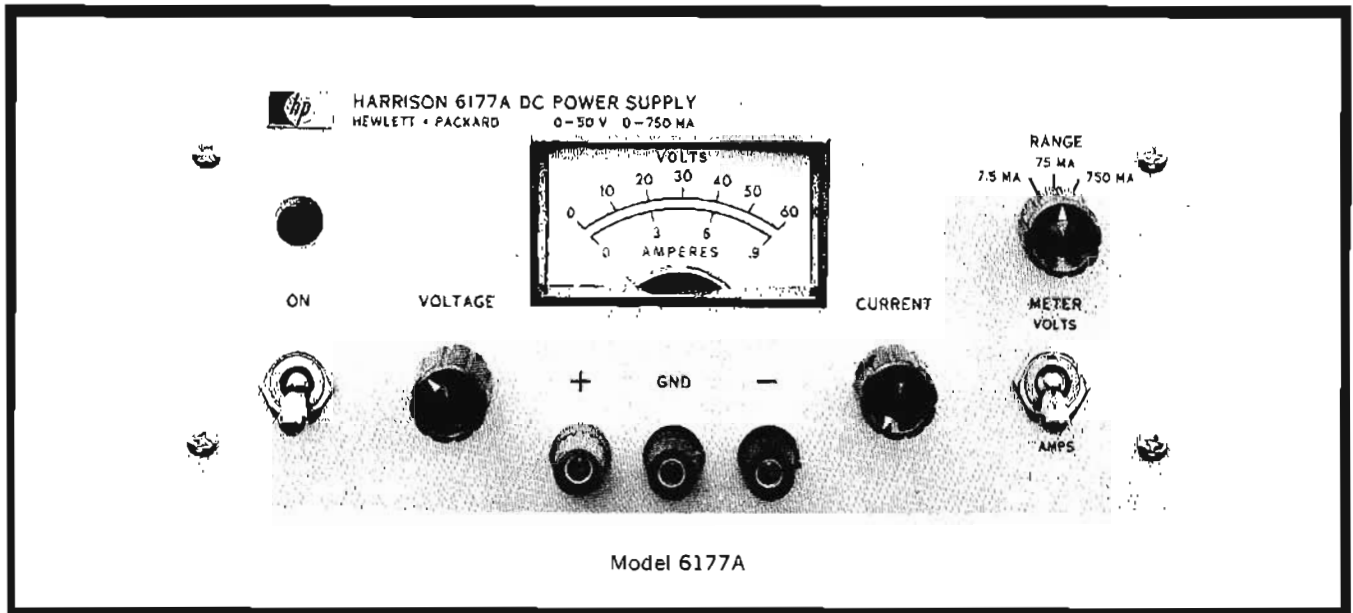

Model 6177A

**Description**

With the CCB Series, Hewlett-Packard has achieved a new concept in moderately priced, precision regulated constant current DC power supplies. These instruments, which employ all-silicon semiconductor circuitry, are much smaller and lighter than any constant current supplies of similar output rating now on the market. Their ripple, regulation, and drift characteristics are orders of magnitude better than comparably priced constant current supplies.

Placing a voltmeter across the output terminals of a standard constant current power supply degrades the load regulation and diminishes the load current. The CCB Series eliminates this error by using an operational amplifier to feed the front panel voltmeter. This "replica" of the output voltage is also presented on rear terminals for possible connection to a more accurate differential or digital voltmeter, thus increasing the utility of these constant current supplies for component testing and sorting systems.

The use of a three-position output range switch and 10-turn output control result in resolution down to  $0.1 \mu\text{a}$ ; special attention has been given to circuit details so that well regulated performance is maintained down to these low output currents.

A considerable number of design precautions contribute to the dc isolation and ac shielding properties which are necessary for a high performance constant current supply. A double box shield technique insures a completely shielded ac power transformer primary; an additional shield is added around the outside of the transformer. Internal guarding techniques prevent switches and other components within the power supply from contributing to leakage and coupling paths which would degrade output performance.

**Applications**

Precision performance, low price, and small size and weight, combine to make CCB Series supplies useful as general purpose laboratory constant current sources for semiconductor circuit development and component evaluation.

In addition, the stability and rapid remote programming characteristics lend these same instruments to diverse applications; such as component testing and sorting zener diodes, diodes, transistors, SCR's, resistors, relays, meters; and precision electroplating, precision electromagnets, etc. The capability of superimposing output ac modulation or of applying a varying dc voltage input permit CCB supplies to be used for measurement of such characteristics as dynamic impedance, voltage breakdown, and leakage resistance.

**Advantages**

- Precision constant current regulation
- Rapid programming
- Output useful to microampere region
- All-silicon circuitry—no tubes
- Compact mechanical design—small size, light-weight
- High speed, full range voltage compliance
- High output impedance over wide frequency band
- Ammeter scales ganged to output range switch
- Remote programming using resistance or voltage control
- Can be modulated from external ac source
- Continuously variable voltage limit
- Auto parallel operation
- Front and rear output terminals
- Floating output can be used as positive or negative source
- No overshoot for turn-on, turn-off, or power removal
- Rack mounting hardware available
- Rear terminals for monitoring output voltage

**CCB SERIES**  
Constant current bench supplies  
Models 6177A—6186A



**DC POWER SUPPLIES**

**Specifications**

MODEL			6177A	6181A	6186A
Output Current			0-750 mA	0-300 mA	0-100 mA
Voltage Compliance			0-50V	0-100V	0-300V
Output Ranges			A.	0-7.5 mA	0-3 mA
			B.	0-75 mA	0-30 mA
			C.	0-750 mA	0-300 mA
Output Current Remote Programming*	Voltage Control	Range A.	100 mV/mA	1V/mA	10V/mA
		Range B.	10 mV/mA	100 mV/mA	1V/mA
		Range C.	1 mV/mA	10 mV/mA	100 mV/mA
	Resistance Control	Range A.	1 k $\Omega$ /mA	10 k $\Omega$ /mA	100 k $\Omega$ /mA
		Range B.	100 $\Omega$ /mA	1 k $\Omega$ /mA	10 k $\Omega$ /mA
		Range C.	10 $\Omega$ /mA	100 $\Omega$ /mA	1 k $\Omega$ /mA
Voltage Limit Remote Programming			200 ohms/V	200 ohms/V	250 ohms/V
Meter Ranges			9, 90, 900 mA, 60V	3.6, 36, 360 mA, 120V	1.2, 12, 120 mA, 360V
Price			\$425	\$425	\$425

\*Other programming coefficients can be achieved using external current monitoring shunts connected to rear terminal barrier strip. Full discussion of techniques and possible limitations included in Instruction Manual.

**AC input:** 105-125/210-250 VAC, 48-63 Hz, 0.7A, 60W.

**Load regulation:** Less than 10 ppm of output + 5 ppm of range switch setting for a load change resulting in an output voltage change from zero to maximum rated output.

**Line regulation:** Less than 10 ppm for a change in line voltage from 105-125 VAC.

**Rms ripple & noise:** Less than 100 ppm of output + 20 ppm of range switch setting.

**Transient recovery time:** Less than 200  $\mu$ s for output current recovery to within 0.1% of the nominal output current following a full load change in output voltage.

**Current programming speed:** Less than 500  $\mu$ sec from zero to 0.99 of maximum output current with an accuracy of 1%.

**Temperature coefficient:** Less than 70 ppm of output + 5 ppm of range switch setting per degree C.

**Stability:** Less than 100 ppm of output + 25 ppm of range switch setting. Stability is measured for eight hours after 30 minutes warm-up under conditions of constant line, load, and temperature.

**Temperature rating:** Operating: 0 to 55°C.  
Storage: -40 to +85°C.

**Load protection:** The continuously variable voltage limit circuit protects both the supply and the load for all conditions including an open circuit load.

**Controls:** Three-position output current and meter range switch, 10-turn output current control, voltage limit control, meter switch, power switch, and pilot light.

**Output terminals:** A positive and negative output terminal are included on the front panel, as well as a ground terminal. The supply may be operated floating or either side may be grounded. A rear panel barrier strip includes output terminals and other terminals necessary for remote programming, ac modulation, and other control functions. Two rear terminals provide a "replica" of the output voltage for connection of a differential or digital voltmeter—1 mA maximum current, accuracy settable to within 5 mV of the output voltage.

**TYPICAL OUTPUT IMPEDANCE (OHMS)**

MODEL	6177A			6181A			6186A		
OUTPUT RANGE (mA)	750	75	7.5	300	30	3	100	10	1
Dc to 100 Hz	$\geq 5M$	$\geq 50M$	$\geq 500M$	$\geq 20M$	$\geq 200M$	$\geq 2G$	$\geq 200M$	$\geq 2G$	$\geq 20G$
100 Hz to 1 kHz	$\geq 1 M\Omega$			1 kHz to 10 kHz			$\geq 100 k\Omega$		
10 kHz to 100 kHz	$\geq 10 k\Omega$			100 kHz to 1 MHz			$\geq 100 \Omega$		

**Size:** 3 $\frac{1}{2}$ " (89 mm) H x 8 $\frac{1}{2}$ " (216 mm) W x 12 $\frac{5}{8}$ " (321 mm) D. Package size is half rack width and is easily rack mounted using accessories listed below.

**Finish:** Light gray front panel with dark gray case.

**Power cord:** A three-wire, 5 ft. (1.52 m) power cord is provided with each unit.

**Option 14:** Three digit graduated decadal current control. This calibrated 10-turn potentiometer replaces the front-panel 10-turn vernier to provide resettability within 0.1%. Add \$35.00.

**Option 28:** Rewire for 230 V, single phase ac input. Unit as normally shipped is wired for 115 VAC input and must be internally reconnected. Add \$10.

**Accessories:** Same as HVB Series. Refer to page 472.



# DC POWER SUPPLIES



## ICS SERIES

Integrated circuit supplies  
Models 6384A—6388A

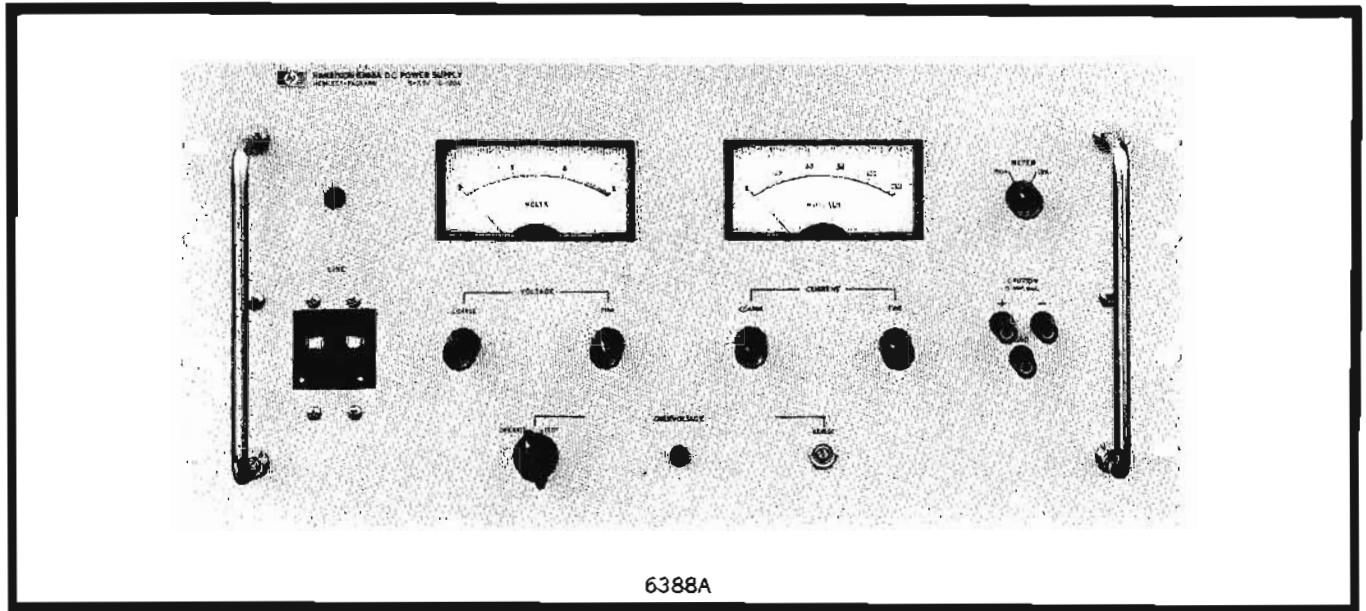

6388A

The ICS Series of well regulated dc constant voltage/constant current power supplies are specifically designed for use with integrated circuits, micromodular circuits, and other low voltage semiconductor circuitry. Included in these rack-width instruments is an overvoltage "crowbar" protection circuit. If for any reason an incipient overvoltage condition occurs, this completely independent circuit shorts the output terminals with an SCR crowbar within 10  $\mu$ s.

A temperature compensated zener diode is employed as the reference element in all-silicon series regulator feedback circuit which monitors and controls the output voltage. The resulting low ripple and low output impedance permit these supplies to be used in critical applications where less well regulated supplies are not suited.

These supplies are short circuit proof and will not be damaged by any overload regardless of how long imposed. The output is floating—thus the supply can be used as either a positive or negative source.

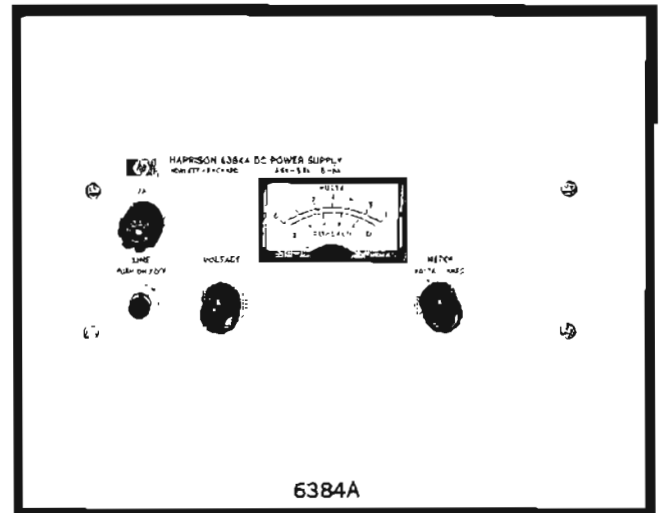

6384A

### Advantages

- All silicon semiconductor circuitry
- Low output drift
- High degree of output resolution
- Low peak to peak ripple and noise
- Low output impedance at all frequencies

- 200  $\mu$ sec load transient recovery
- No overshoot for turn-on, turn-off, or power removal
- Floating output—can be used as positive or negative source
- Fully rated for any overload condition including continuous short circuit operation

### Additional Advantages, Models 6385A—6388A

- Remote programming—voltage and current can be controlled by external resistance or voltage
- Remote error sensing
- Continuously variable output voltage and current—no range switching
- Auto-series, auto-parallel and auto-tracking operation
- Constant voltage/constant current operation with automatic crossover; Model 6384A—constant voltage/current limiting

- Front panel coarse and fine voltage and current controls
- Both voltage comparison amplifier and current comparison amplifier employ "diffamps" (matched silicon differential amplifier package) for improved stability
- Sharp cut-over from constant voltage to constant current operation
- Front panel voltmeter and multiple-range ammeter

# ICS SERIES

Integrated circuit supplies  
Models 6384A—6388A



## DC POWER SUPPLIES

### Specifications

MODEL		6384A*	6385A	6386A	6387A	6388A
Output	DC Voltage	4–5.5 V	0–7.5 V	0–7.5 V	0–7.5 V	0–7.5 V
	DC Current	0–8 A	0–15 A	0–30 A	0–60 A	0–120 A
Input 48–63 Hz		115/230 V ac=10% 1.35 A, 120 W @ 115 V ac	115/208/230 V ac=10%	115/208/230 V ac=10%	115/208/230 V ac=10%	208/230 V ac=10%
Remote programming All Programming terminals are located on rear barrier strips.	CV	—	200 Ω/V	200 Ω/V	200 Ω/V	200 Ω/V
	CC	—	8 Ω/A	4 Ω/A	2 Ω/A	1 Ω/A
Meter ranges		0–6 V 0–10 A	0–9 V 0–1.8 A, 0–18 A	0–9 V 0–4 A, 0–40 A	0–9 V 0–7 A, 0–70 A	0–9 V 0–15 A, 0–150 A
Size	Inches	8½ W x 3½ H x 12¾ D	19 W x 5¼ H x 17½ D	19 W x 5¼ H x 17½ D	19 W x 8¼ H x 17½ D	19 W x 8¼ H x 17½ D
	Centimeters	21.6 W x 8.9 H x 32.1 D	48.3 W x 14 H x 44.4 D	48.3 W x 14 H x 44.4 D	48.3 W x 22.2 H x 44.4 D	48.3 W x 22.2 H x 44.4 D
Weight	lbs	12/15	—	—	—	110/125
Net/Shipping	kg	5.44/6.8	—	—	—	49.8/56.5
Price		\$220	\$450	\$700	\$825	\$1050
Options Refer to page 469 for description.		05–\$10, 28–\$10	05–\$10, 10–\$125 27–\$10, 28–\$10	05–\$10, 10–\$125 27–\$10, 28–\$10	05–\$10, 10–\$125 26–\$10, 27–\$10	05–\$10, 10–\$125 27–\$10

No charge for option 05 if ordered with option 26, 27, or 28

CV Indicates constant voltage. CC Indicates constant current. \*Model 6384A is a constant voltage current limit supply.

#### Load regulation:

CV—Less than 1 mV from no load to full load.

CC—Less than 0.03% + 2 mA of output from no load to full load.

#### Line regulation:

CV—Less than 1 mV for a 10% change in the nominal line voltage.

CC—Less than 0.03% + 2 mA for a 10% change in the nominal line voltage.

**Transient recovery time:** Less than 200 μseconds (50 μs for 6384A) is required for output voltage recovery in constant voltage operation to within 50 millivolts (10 mV for 6384A) of the nominal output voltage following a 20% change in output current. The nominal output voltage is defined as the mean between the no load and full load voltages.

**Temperature coefficient:** Output change per degree centigrade change in ambient following 30 minutes warm-up

CV—0.01% + 200 μV

CC—0.01% + 10 mA

**Stability:** Under constant ambient conditions, total drift for 8 hrs. following 30 minutes warm-up

CV—0.03% + 1 mV, except 10 mV for 6384A

CC—0.03% + 30 mA

**Output terminals:** A rear barrier strip includes GND, +out, –out, + sensing, and –sensing terminals.

Either side of the supply may be grounded or the output may be operated floating at potentials of up to 300 V off ground.

Models 6385A, 6388A include monitoring output terminals mounted on the front panel (3 amps maximum).

**Finish:** Light gray front panel with dark gray case.

**Power cord:** A three wire 5 ft. (1.52 m) power cord is provided on all models except 6387A and 6388A which have a rear barrier strip.

**Accessories, Model 6384A:** Same as HVB Series. Refer to page 472.

**Ripple and noise:** At any line voltage and any load condition

within rating

CV—5mV p-p, 1mV rms

CC—50mA rms

**Temperature rating:** Operating: 0 to 55°C

Storage: –40 to +71°C

#### Output impedance:

Less than 0.001 ohm from dc to 100 Hz

Less than 0.01 ohm from 100 Hz to 1 kHz

Less than 0.05 ohm from 1 kHz to 10 kHz

Less than 0.2 ohm from 10 kHz to 100 kHz

Less than 2 ohms from 100 kHz to 1 MHz

#### Protection:

**Short circuit protection:** The output is current limited and is fully rated for operation under any overload condition including a direct short circuit, regardless of how long maintained. Supply will automatically restore to normal operation upon overload removal.

**Overvoltage protection:** An independent built-in overvoltage crowbar circuit prevents the output voltage from exceeding a preset voltage under any failure condition. This crowbar circuit shorts the output within 10 μs following the onset of the over-voltage condition.

Model 6384A: The crowbar threshold voltage is variable between 4.5 and 6.0 volts by monitoring rear terminals while adjusting an internal screwdriver control.

Models 6385A, 6388A: The crowbar threshold voltage is variable between 1.5 and 10 volts by adjusting a front-panel control.

#### Controls:

**Model 6384A:** Single-turn output voltage control, combined off-on switch and pilot light, and switch that selects voltage or current meter.

**Models 6385A, 6388A:** Ten-turn coarse and single-turn fine voltage and current controls, off-on circuit breaker, pilot light, switch that selects current meter scale, over-voltage crowbar controls that set the threshold voltage.

# DC POWER SUPPLIES



## LVR SERIES

Low voltage rack supplies  
Models 6260A-6274A



Models 6263A, 6265A, 6266A, 6271A

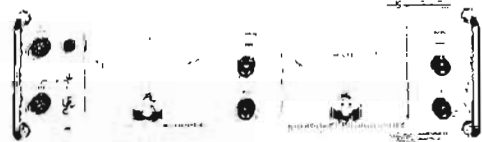

Models 6264A, 6267A

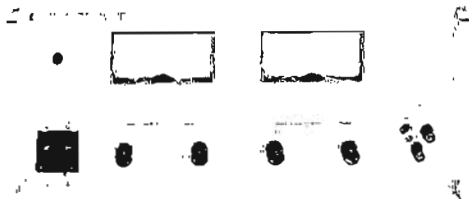

Models 6260A, 6268A, 6269A



Model 6274A

Model		6260A*	6263A	6264A	6266A
DC output		0-10 volts @ 0-100 amps	0-18 volts @ 0-10 amps	0-18 volts @ 0-20 amps	0-36 volts @ 0-3 amps
AC input		230 ± 10% V ac 48-63 Hz 11 A, 1700 W	100-130/200-260 V ac 48-63 Hz, 4.3 A, 265 W @ 115 V	100-130/200-260 V ac 48-63 Hz, 7 A, 500 W @ 115 V	100-130/200-260 V ac 48-63 Hz, 2 A, 160 W @ 115 V
Load regulation: the constant voltage load regulation specification is given for a load current change equal to the current rating of the supply. The constant current load regulation specification is given for the load voltage change equal to the voltage rating of the supply.	cv	0.01% plus 200 μV	0.01% plus 200 μV	0.01% plus 200 μV	0.01% plus 200 μV
	cc	0.03% plus 2 mA	0.02% plus 500 μA	0.02% plus 500 μA	0.02% plus 500 μA
Line regulation: for a change in line voltage from 100 to 130 or 200 to 260 at any output voltage and current within rating.	cv	0.01% plus 200 μV	0.01% plus 200 μV	0.01% plus 200 μV	0.01% plus 200 μV
	cc	0.03% plus 2 mA	0.02% plus 500 μA	0.02% plus 500 μA	0.02% plus 500 μA
Ripple and noise: at any line voltage and under any load condition within rating.	cv	1 mV rms	500 microvolts rms	500 microvolts rms	500 microvolts rms
	cc	50 mA rms	3 mA rms	5 mA rms	3 mA rms
Temperature coefficient: output change per degree centigrade change in ambient following 30 minutes warmup.	cv	0.01% plus 200 μV	0.01% plus 200 μV	0.01% plus 200 μV	0.01% plus 200 μV
	cc	0.01% plus 8 mA	0.01% plus 2 mA	0.01% plus 2 mA	0.01% plus 1 mA
Remote programming: all programming terminals are located on rear barrier strips.	cv	200 ohms/volt	200 ohms/volt	200 ohms/volt	200 ohms/volt
	cc	2 ohms/amp	100 ohms/amp	10 ohms/amp	300 ohms/amp
Meters		0-12 V and 0-120 A	0-20 V and 0-12 A	0-20 V and 0-20 A	0-40 V and 0-3 A
Input power connections		Barrier Strip	3-Wire, 5-Foot Cord	3-Wire, 5-Foot Cord	3-Wire, 5-Foot Cord
Size: height x depth x width	inches	7 H x 17½ D x 19 W	3½ H x 17½ D x 19½ W	5¼ H x 17½ D x 19 W	3½ H x 17½ D x 19 W
	centimeters	17,8 H x 44,4 D x 48,3 W	8,9 H x 44,4 D x 48,3 W	14 H x 44,4 D x 48,3 W	8,9 H x 44,4 D x 48,3 W
Weight: (lbs) (net/shipping)		90 (44,8 kg)/115 (52,2 kg)	36 (16,3 kg)/50 (22,8 kg)	57 (25,9 kg)/72 (32,7 kg)	28 (12,7 kg)/41 (18,6 kg)
Price		\$775	\$435	\$525	\$350
Options: refer to page 469 for descriptions.		06-\$275, 26-\$50, 27-\$15	06-\$125, 28-\$10	06-\$175, 28-\$10	06-\$95, 28-\$10
		05-\$10 No charge if ordered with Option 26, 27, or 28. 10-\$125, 13-\$35, 14-\$35			

cv = constant voltage cc = constant current \*All silicon

## LVR SERIES

### Low voltage rack supplies

Models 6260A-6274A



## DC POWER SUPPLIES

### Advantages

Internally adjustable preregulator voltage limit  
 Continuously variable output voltage and current—  
 no range switching  
 Auto-series, auto-parallel and auto-tracking operation  
 Remote programming—voltage and current can be  
 controlled by external resistance or control voltage  
 Remote error sensing  
 Low output impedance

Automatic restoration of normal operation following  
 removal of overload  
 Constant voltage/constant current operation with  
 automatic crossover  
 Front panel coarse and fine voltage and current controls  
 Fully rated for any overload condition including  
 continuous short circuit operation  
 Front panel voltmeter and ammeter  
 RFI conformance to MIL-I-6181D

### Specifications

**Radio frequency interference:** Models 6260A, 6268A, 6269A,  
 and 6274A are free from conducted and radiated RFI to the extent  
 that they meet all the requirements of MIL-I-6181D.

**Maximum operating temperature:** 0 to 55°C. Storage: -20 to  
 +71°C.

**Internal impedance as a constant voltage source:**

Less than .001 ohms from dc to 100 Hz.  
 Less than .01 ohms from 100 Hz to 1 kHz.  
 Less than .2 ohms from 1 kHz to 100 kHz.  
 Less than 2 ohms from 100 kHz to 1 MHz.

**Transient recovery time:** less than 50 microseconds is required for  
 output voltage recovery (in constant voltage operation) to within  
 10 millivolts of the nominal output voltage following a 5 amp  
 change in output current.

**Output terminals:** an output terminal strip is located on the rear of  
 the chassis. All power supply terminals are isolated from the  
 chassis and either the positive or negative terminal may be con-  
 nected to the chassis through a separate ground terminal located  
 adjacent to the output terminals. Models 6260A, 6268A, 6269A  
 and 6274A include front panel output terminals. They are banana  
 jack type and limited to 3 amps maximum current output.

**Finish:** light gray front panel with dark gray case.

6268A	6267A	6288A*	6269A*	6271A	6274A*
0-36 volts @ 0-5 amps	0-36 volts @ 0-10 amps	0-40 volts @ 0-30 amps	0-40 volts @ 0-50 amps	0-60 volts @ 0-3 amps	0-60 volts @ 0-15 amps
100-130/200-260 V ac, 48-63 Hz, 4.3 A, 265 W @ 115 V	100-130/200-260 V ac, 48-63 Hz, 7 A, 500 W @ 115 V	230 ± 10% V ac 48-63 Hz, 11 A, 1600 W	230 ± 10% V ac 48-63 Hz, 18 A, 2600 W	100-130/200-260 V ac, 48-63 Hz, 4.3 A, 265 W @ 115 V	100-130 Vac, 48-63 Hz, 16 A, 1700 W
0.01% plus 200 μV	0.01% plus 200 μV	0.01% plus 200 μV	0.01% plus 200 μV	0.01% plus 200 μV	0.01% plus 200 μV
0.02% plus 500 μA	0.02% plus 500 μA	0.02% plus 3 mA	0.02% plus 3 mA	0.02% plus 500 μA	0.02% plus 2 mA
0.01% plus 200 μV	0.01% plus 200 μV	0.01% plus 200 μV	0.01% plus 200 μV	0.01% plus 200 μV	0.01% plus 200 μV
0.02% plus 500 μA	0.02% plus 500 μA	0.02% plus 3 mA	0.02% plus 3 mA	0.02% plus 500 μA	0.02% plus 2 mA
500 microvolts rms 3 mA rms	500 microvolts rms 3 mA rms	1 mV rms 20 mA rms	1 mV rms 30 mA rms	500 microvolts rms 3 mA rms	500 microvolts rms 10 mA rms
0.01% plus 200 μV	0.01% plus 200 μV	0.01% plus 500 μV	0.01% plus 200 μV	0.01% plus 200 μV	0.01% plus 200 μV
0.01% plus 2 mA	0.01% plus 2 mA	0.01% plus 2 mA	0.01% plus 4 mA	0.01% plus 1 mA	0.01% plus 2 mA
200 ohms/volt	200 ohms/volt	200 ohms/volt	200 ohms/volt	300 ohms/volt	300 ohms/volt
200 ohms/amp	100 ohms/amp	6 ohms/amp	4 ohms/amp	300 ohms/amp	50 ohms/amp
0-40 V and 0-6 A	0-40 V and 0-10 A	0-50 V and 0-40 A	0-50 V and 0-60 A	0-60 V and 0-3 A	0-70 V and 0-18 A
3-Wire, 5-Foot Cord	3-Wire, 5-Foot Cord	Barrier Strip	Barrier Strip	3-Wire, 5-Foot Cord	Barrier Strip
3½ H x 17½ D x 19 W	5½ H x 17½ D x 19 W	7 H x 16¼ D x 19 W	7 H x 17½ D x 19 W	3½ H x 17½ D x 19 W	5½ H x 17½ D x 19 W
8,9 H x 44,4 D x 48,3 W	14 H x 44,4 D x 48,3 W	17,8 H x 42,7 D x 48,3 W	17,8 H x 44,4 D x 48,3 W	8,9 H x 44,4 D x 48,3 W	14 H x 44,4 D x 48,3 W
33 (15 kg)/48 (21,8 kg)	52 (23,6 kg)/67 (30,4 kg)	93 (42,2 kg)/120 (54,5 kg)	93 (42,4 kg)/120 (54,5 kg)	33 (15 kg)/45 (20,4 kg)	75 (34 kg)/95 (43,1 kg)
\$435	\$525	\$695	\$875	\$435	\$695
06-\$95, 28-\$10	06-\$125, 28-\$10	06-\$175, 26-\$10, 27-\$15	06-\$200, 27-\$15	06-\$95, 28-\$10	06-\$175, 27-\$50, 28-\$50
05-\$10 No charge if ordered with Option 26, 27, or 28		10-\$125	13-\$35	14-\$35	

\*All silicon

## DC POWER SUPPLIES



## MVR and HVR SERIES

Medium and high voltage rack supplies  
Models 890A, 895A and 6521A—6525A

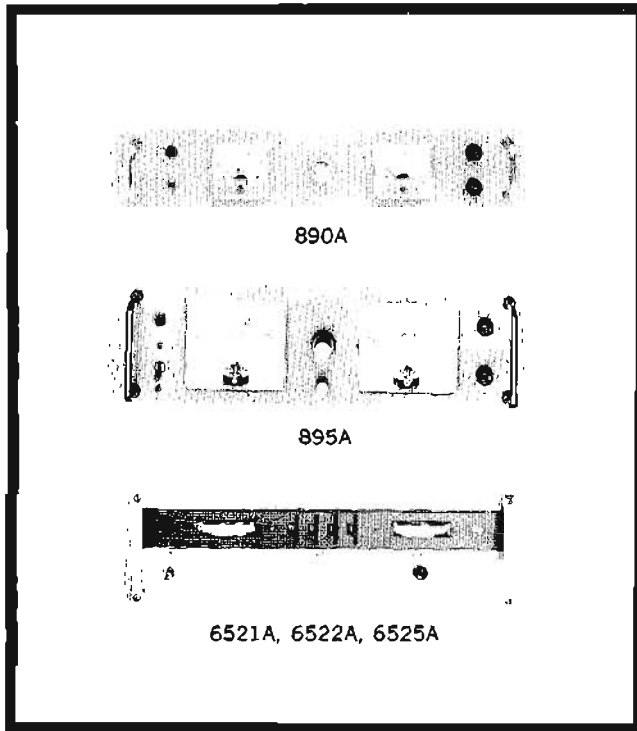

### Advantages, MVR Series:

- All solid-state
- Short-circuit proof
- Remote programming, remote error sensing

### Advantages, HVR Series:

- All solid-state, compact rack mounting
- 200 watt output
- Short circuit proof
- $\pm$  output—grounded or floating up to 2 kV off ground
- Decade voltage switching with 0.002% resolution
- Transient recovery time: less than 50 microseconds to within 0.005% or 20 mV, whichever is greater
- 1% calibration accuracy

The MVR Series features a unique "Piggy-Back" circuit; low voltage series power transistors, which are required to dissipate only a fraction of their power rating, provide high regulation—yet the supply can withstand a direct short circuit across the output terminals.

The HVR Series consists of three high-voltage supplies utilizing all silicon semiconductor circuitry—no tubes. All three supplies are tightly regulated and provide sufficient output current for many devices not capable of being powered from conventional low-current, high-voltage supplies. These supplies feature constant voltage/constant current operation with automatic crossover. Elimination of large series dissipating tube elements allows these supplies to have efficiencies approaching 80%.

### MVR Series

Model		890A	895A
DC output	volts	0 to 320	0 to 320
	amps	0 to 0.6	0 to 1.5
Line or load regulation		0.007% or 10 mV	
Ripple and noise (rms maximum)		1 mV	
Meters		320 V and 0.8 A	
Dimensions		3 1/4" H x 16 1/4" D x 19" W (88 x 425 x 483 mm)	5 1/4" H x 16 1/4" D x 19" W (133 x 425 x 483 mm)
Weight (net/shipping)		35/43 lbs (15.8/19.4 kg)	50/66 lbs (22.5/29.7 kg)
Price		\$445	\$625

#### All MVR models

**Short circuit proof:** all-electronic, continuously acting current limit circuit protects the supply for all overloads, including a direct short placed across the output terminals; in addition, a fuse will blow when severe overload conditions occur.

**Maximum operating temperature:** 50°C.

**Temperature coefficient:** less than 0.03%, plus 1.5 mV/°C.

**Stability:** better than 0.1% plus 5 mV.

**Transient recovery time:** less than 100 microseconds.

**Output terminals:** output terminal strip is located on the rear of the chassis.

**Input ac:** 105 to 125 V, 57 to 63 Hz.

### HVR Series

Model		6521A	6522A	6525A
DC output	voltage	0 to 1000 V	0 to 2000 V	0 to 4000 V
	current	0 to 200 mA	0 to 100 mA	0 to 50 mA
AC input		105 to 125 V ac, 50 to 500 Hz		
Load regulation	constant voltage	0.005% or 20 mV		
	constant current	2% or 1 mA		
Line regulation	constant voltage	0.005% or 20 mV		
	constant current	1 mA		
Ripple and noise (rms maximum)	constant voltage	1 mV rms		
	constant current	2 mA	1 mA	500 $\mu$ A
Temp. coefficient (output change per °C change in ambient following 30 min warm-up)	constant voltage	0.012% plus 1 mV		
	constant current	0.2% plus 0.2 mA	0.2% plus 0.1 mA	0.2% plus 0.05 mA
	constant current	0.036% plus 3 mV		
Stability (under constant ambient conditions, total drift for 8 hours following 60 min warm-up)	constant voltage	0.25% plus 0.5 mA	0.25% plus 0.25 mA	0.25% plus 0.12 mA
	constant current	0.036% plus 3 mV		
Meters		0 to 1 kV and 0 to 200 mA	0 to 2 kV and 0 to 100 mA	0 to 4 kV and 0 to 50 mA
Controls		voltage control—3 decade thumbwheel switches, plus thumbwheel vernier with 0.002% resolution. current control—single-turn potentiometer		
Dimensions		5 1/4" H x 18" D x 19" W (132 x 457 x 483 mm)		
Weight (net/shipping)		50/60 lbs (22.5/27 kg)		
Price		\$750	\$750	\$750

# SCR-1P SERIES & MODEL 520A

Compact SCR regulated supplies  
Models 6427B-6448B & 520A



## DC POWER SUPPLIES

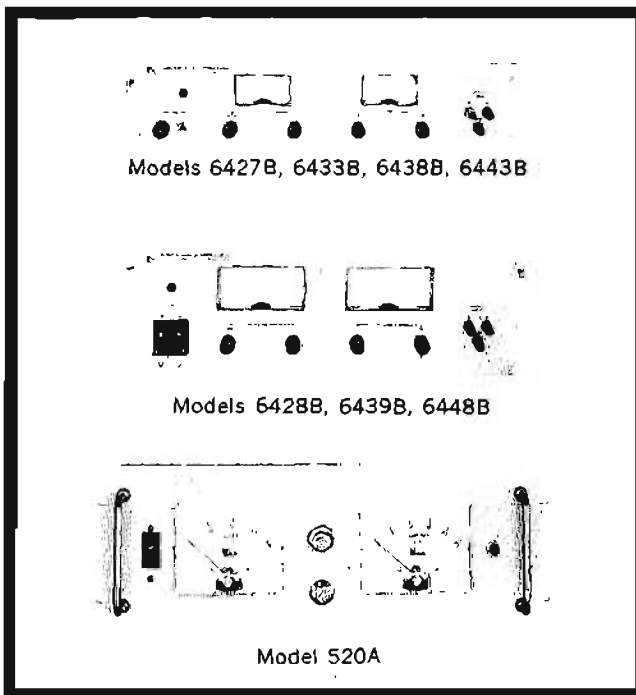

The SCR-1P Series consists of seven regulated dc power supplies utilizing all-silicon circuitry. Silicon-controlled rectifiers in series with the transformer primary, and controlled by the output voltage and current settings, accomplish the desired regulation using Harrison's unique "Ramp-Lock" phase control circuit. This circuit technique permits a reduction in the overall size and weight of the power supply and results in up to 75% efficiency at full output. Four models with output ratings of approximately 300 watts are packaged in a 3½" high rack mounting cabinet, while the three models with approximately 900 watt output power capability are 5¼" high. All supplies may also be used on the bench (attachable rubber feet for bench use available on request). These second generation SCR regulated power supplies also feature lower output ripple, tighter load and line regulation, and Constant Voltage/Constant Current operation with automatic crossover.

Model 520A is similar in design and performance to the SCR-1P Series.

### Advantages:

- Output continuously variable to zero in either voltage or current mode
- All-silicon circuitry
- Efficiency up to 75% at full output
- Excellent line transient immunity

Model		6427B	6428B	6433B	6438B	6439B	6443B	6448B	520A
DC output	volts	0-20	0-20	0-36	0-60	0-60	0-120	1-600	0-36
	amps	0-15	0-45	0-10	0-5	0-15	0-2.5	0-1.5	0-25
AC power in	volts	105-125 V ac, 57-63 Hz							
	amps	6.5	17	7	6.5	17	6.5	16	16.8
	watts	450	1200	450	400	1200	400	1200	1100
Line regulation: For a change in ac line voltage from 105 to 125 or 125 to 105.	constant voltage	10 mV	20 mV	18 mV	30 mV	60 mV	60 mV	600 mV	0.5% or 50 mV
	constant current	150 mA	450 mA	100 mA	50 mA	150 mA	25 mA	15 mA	250 mA
Constant voltage load regulation: for a change in output current from no load to full load or full load to no load.		20 mV	40 mV	36 mV	60 mV	120 mV	120 mV	600 mV	0.5% or 50 mV
Constant current load regulation: for a change in output voltage from no load to full load or full load to no load.		150 mA	450 mA	100 mA	50 mA	150 mA	25 mA	15 mA	250 mA
Full scale meter readings: meters have 2% accuracy; all units have meter calibrating potentiometers.		24 V & 18 A	24 V & 50 A	40 V & 12 A	70 V & 6 A	70 V & 18 A	150 V & 3 A	700 V & 1.8 A	40 V & 25 A
*Transient recovery time: <200 ms (50 ms for 520A for output recovery to within "A" mV; transient amplitude less than "B" volts/amp for any load change between 20% and 100% of rated output current.	A = 200	A = 200	A = 200	A = 300	A = 600	A = 600	A = 3000	A = 200	
	B = 0.35	B = 0.15	B = 0.5	B = 1.0	B = 0.4	B = 4.0	B = 20	B = 0.1	
*Ripple and noise: rms maximum		40 mV	40 mV	36 mV	120 mV	60 mV	240 mV	600 mV	360 mV
Remote programming	constant voltage	200 ohms/volt	200 ohms/volt	200 ohms/volt	300 ohms/volt	300 ohms/volt	300 ohms/volt	300 ohms/volt	
	constant current	15 ohms/amp	5 ohms/amp	25 ohms/amp	50 ohms/amp	15 ohms/amp	100 ohms/amp	170 ohms/amp	
Size: W x H x D	inches	19 x 3½ x 17	19 x 5¼ x 16½	19 x 3½ x 17½	19 x 3½ x 17½	19 x 5¼ x 16½	19 x 3½ x 17½	19 x 5¼ x 16½	19 x 7 x 16½
	centimeters	48,3 x 8,9 x 44	48,3 x 14 x 43,7	48,3 x 8,9 x 44,4	48,3 x 8,9 x 44,4	48,3 x 14 x 43,7	48,3 x 8,9 x 44,4	48,3 x 14 x 43,7	48,3x17,8x41,9
Weight (net/shipping)	pounds	36/51	67/76	33/48	31/46	61/70	31/46	61/70	85/101
	kilograms	16.3/23.1	30.4/34.4	14.9/21.7	14/20.8	27.6/31.7	14/20.8	27.6/31.7	38.5/45.8
Price		\$380	\$550	\$370	\$360	\$550	\$360	\$550	\$575
Options: refer to page 469 for descriptions.					05-\$10	10-\$125			

\*Use of supply at 50 Hz input (possible only with option 05) results in a 50% increase in transient recovery time and ripple.

# DC POWER SUPPLIES



## SCR-3 SERIES

3 KW SCR regulated supplies  
Models 6453A-6459A

The SCR-3 Series of regulated supplies are suitable for high-power applications which require up to 200 amps output current and up to 3.6 kilowatts output power. These supplies can be connected in Auto-Series and Auto-Parallel for higher power applications. In this series of supplies, silicon-controlled rectifiers perform simultaneously the rectifying and regulating functions with resulting voltage regulation of less than 0.3%.

### Advantages:

- Constant voltage/constant current
- Minimum size, reduced weight
- Continuously variable to zero volts
- Excellent line transient immunity
- 50 millisecond recovery for load current changes
- Short-circuit-proof
- Remote programming
- Remote error sensing
- Auto-series and auto-parallel operation
- 75% efficiency at full load

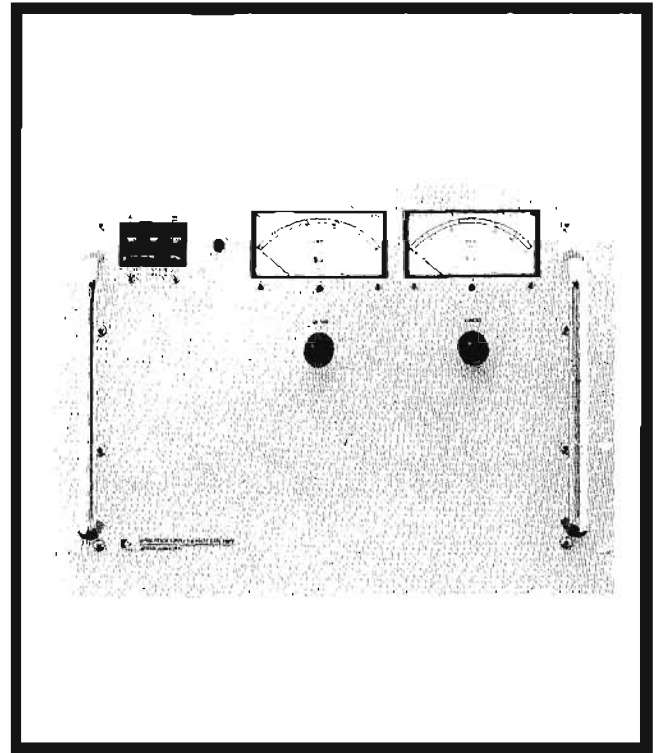

Model		6453A	6458B	6459A
DC volts out		0 to 15 V	0 to 36 V	0 to 64 V
DC amps out		0 to 200 A	0 to 100 A	0 to 50 A
AC power in		208/230/460 = 10%, 3 phase, 57 to 63 Hz; 14 amps per phase		
Combined load and line regulation	cv	0.2% + 10 mV	0.2% + 10 mV	0.2% + 10 mV
	cc	1% or 2 A	1% or 1 A	1% or 500 mA
†Ripple and noise (rms max., specified as percent of max. output voltage)		1%	0.5%	0.25%
Remote programming (all programming terminals located on rear barrier strips)	cv	200 ohms/volt	200 ohms/volt	300 ohms/volt
	cc	1 ohm/amp	2 ohms/amp	4 ohms/amp
†Transient recovery time (less than 50 msec required for output voltage recovery to within A mV of nominal output voltage following a load change from full load to half load or half load to full load)		A = 150	A = 300	A = 600
Meters		20 V and 200 A	40 V and 100 A	80 V and 50 A
Input terminals		4-terminal twist lock connector		
Output terminals		tapped rectangular bus bars		
Cooling		internal fan		
Dimensions		19" W, 14" H, 18½" D (356 x 483 x 476 mm)	19" W, 14" H, 18½" D (356 x 483 x 476 mm)	19" W, 14" H, 18½" D (356 x 483 x 476 mm)
Weight (net/shipping)		238/275 lbs (107/124 kg)	238/275 lbs (107/124 kg)	238/275 lbs (107/124 kg)
Price: Option 01, 02, or 03 must be specified when ordering		\$1375	\$1275	\$1275
Options: Refer to page 469 for description		05-\$25, 06-\$350	05-\$25, 06-\$300	05-\$25, 06-\$300
		01-208 V ac input—no charge, 02-230 V ac input—no charge, 03-460 V ac input—\$40, 10-\$195		

cc = constant current, cv = constant voltage

†Use of supply at 50 Hz input (possible only with option 05) results in a 50% increase in transient recovery time and ripple.



# SCR-10 SERIES

## 10 KW SCR regulated supplies

Model 6463A—6483B



## DC POWER SUPPLIES

The SCR-10 Series of all silicon, 10 kilowatt regulated supplies are intended for high power applications which require a fixed or variable dc source with a moderate degree of regulation. Silicon-controlled rectifiers in series with the transformer primary, and controlled by the output voltage and current settings, accomplish the desired regulation using Harrison's "Ramp-Lock" phase control circuit. This circuit technique permits a reduction in the overall size and weight of the power supply and results in up to 75% efficiency at full output. All features of the SCR-10 Series are the same as given for the SCR-3 Series on the previous page.

### Specifications

**Controls:** a single control allows continuous adjustment of output voltage over the entire output range. A single control allows continuous adjustment of output current over the entire output range. Models 6475A, 6477A, 6479A, and 6483B have 10-turn voltage controls.

**Input terminals:** a 4-pin jack and mating connector are supplied.

**Output terminals:** tapped rectangular bus bars.

**Cooling:** internal fan.

**Size:** standard 19 inch (483 mm) relay rack mounting, 26 1/4 inches (669 mm) and 22 1/2 inches (572 mm) deep.

**Weight:** 120 lbs (191 kg) net, 500 lbs (227 kg) shipping weight.

**Finish:** light gray front panel with dark gray case.

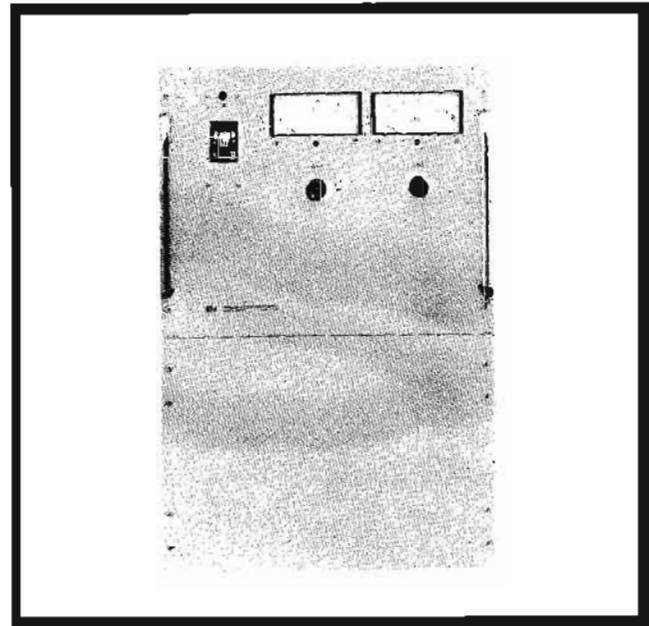

Model	6463A	6464A	6468A	6469A	6472A	6476A	6477A	6479A	6483B	
DC output	volts	0-4	0-8	0-16 or 0-18	0-36	0-64	0-110	0-220	0-300	0-440 or 0-500 or 0-600
	amps	0-2000	0-1000	0-600 or 0-500	0-300	0-150	0-100	0-50	0-35	0-15 or 0-20 or 0-25
AC input	volts	208/230/460 $\pm$ 10%, 3 Phase, 57-63 Hz, Specify by option number, see below								
	amps	less than 50 amps per phase at 230 V ac								
Combined line and regulation constant voltage: for a change in output current from no load to full load or full load to no load combined with a $\pm$ 10% change in line voltage		50 mV	25 mV	0.2% plus 10 mV	0.2% plus 10 mV	0.2% plus 100 mV	0.2% plus 100 mV	0.2% plus 100 mV	0.2% plus 100 mV	0.2% plus 100 mV
Combined line and load regulation constant current: for a change in output voltage from no load to full load or full load to no load combined with a $\pm$ 10% change in line voltage.		1% or 20 A	1% or 10 A	1% or 6 A	1% or 3 A	1% or 1.5 A	1% or 1 A	1% or 0.5 A	1% or 0.3 A	1% or 0.2 A
Full scale meter readings: meters have 2% accuracy; all units have meter calibrating potentiometers.		5 V & 2400 A	10 V & 1200 A	18 V & 700 A	40 V & 350 A	80 V & 180 A	125 V & 120 A	250 V & 60 A	350 V & 40 A	600 V & 25 A
*Transient recovery time: less than 50 milliseconds is required for output voltage recovery to within 1 millivolts of the nominal output voltage following a load change from full load to half load or half load to full load, or a change of 100 amperes, whichever is less.		—	A = 150	A = 150	A = 500	A = 600	A = 1 V	A = 2 V	A = 3 V	A = 5 V
Ripple and noise: rms maximum, specified as percent of maximum output voltage.		7%	1%	1%	0.5%	0.25%	0.2%	0.15%	0.1%	0.1%
Temperature coefficient: output change per degree centigrade change in ambient following 30 minutes warmup.	cv	0.05% plus 2 mV								
	cc	12 A	6.0 A	3.6 A	1.8 A	0.9 A	0.6 A	0.3 A	0.2 A	0.1 A
Stability: under constant ambient conditions, total drift for 8 hours following 30 minutes warmup.	cv	0.25% plus 10 mV								
	cc	60 A	30 A	18 A	9 A	4.5 A	3 A	1.5 A	1 A	0.5 A
Remote programming	cv	200 $\Omega$ /V	200 $\Omega$ /V	200 $\Omega$ /V	200 $\Omega$ /V	300 $\Omega$ /V	300 $\Omega$ /V	300 $\Omega$ /V	300 $\Omega$ /V	300 $\Omega$ /V
	cc	0.1 $\Omega$ /A	1/5 $\Omega$ /A	1/3 $\Omega$ /A	1/2 $\Omega$ /A	1.5 $\Omega$ /A	2 $\Omega$ /A	4 $\Omega$ /A	6 $\Omega$ /A	10 $\Omega$ /A
Price: Option 01, 02, or 03 must be specified when ordering.		\$3500	\$3300	\$2600	\$2300	\$2600	\$2600	\$2600	\$2600	\$2600
Options: refer to page 469 for descriptions.	06	—	—	\$500	\$450	\$400	\$400	\$300	\$300	\$300
		01-208 V ac input-no charge, 02-230 V ac input-no charge, 03-460 V ac input-\$200, 04-\$85, 05-\$25, 10-\$225								

cv = constant voltage cc = constant current

1Use of supply at 50 Hz input (possible only with option 05) results in a 50% increase in transient recovery time and ripple

# DC POWER SUPPLIES



## MOD SERIES

Modular plug-in supplies  
Models 6343A-6357A

The MOD Series of plug-in modular power supplies has been designed to meet the need for well regulated, inexpensive chassis-mounting supplies and the need for a line of dc supplies of low power rating capable of being efficiently grouped on rack panels. All input, output and control connections are accomplished via the 11-pin plug mounted at one end of the supply. Since the output voltage is determined by the value of a resistor connected between two of these terminals, these supplies can be made to be continuously variable over their entire output voltage range, or variable over some limited range, or fixed at some predetermined value—depending upon the manner in which the external rheostats and/or resistors are connected to the programming terminals.

A current limiting overload protection circuit is used in all MOD Series supplies. The current limit can be set at any value from zero to some value slightly greater than the current rating of the supply. This current setting is accomplished by means of a screwdriver adjustment slot accessible through a small hole in the side of the supply, thus permitting readjustment of the current limit value without removing the power supply module's cover.

The supply is thus fully protected for any overload condition, including a direct short circuit across the output terminals, and the current limit control can be set to the exact value necessary for optimum protection of the load device. No fuses are contained in the MOD Series supplies.

### Specifications, MOD Series

Model	Output rating	Load regulation	Line regulation	Input power	Size	Weight (net/shipping)	Price	Options*
6343A	0 to 18 V at 0 to 300 mA	3 mV or 0.03%	3 mV or 0.03%	105 to 125 or 210 to 250 V ac, 48 to 440 Hz	A	3/5 lbs. (1,4/2,3 kg)	\$120	05—\$10 28—\$10
6344A	0 to 18 V at 0 to 1 A	3 mV or 0.03%	3 mV or 0.03%	105 to 125 or 210 to 250 V ac, 48 to 63 Hz	B	7/10 lbs (3,2/4,5 kg)	\$165	05—\$10 28—\$10
6345A	0 to 18 V at 0 to 2.5 A	3 mV or 0.03%	3 mV or 0.03%	105 to 125 or 210 to 250 V ac, 48 to 63 Hz	C	13/19 lbs (5,9/8,6 kg)	\$225	05—\$10 28—\$10
6346A	0 to 36 V at 0 to 150 mA	3 mV or 0.02%	3 mV or 0.02%	105 to 125 or 210 to 250 V ac, 48 to 440 Hz	A	3/5 lbs (1,4/2,3 kg)	\$120	28—\$10
6347A	0 to 36 V at 0 to 500 mA	3 mV or 0.02%	3 mV or 0.02%	105 to 125 or 210 to 250 V ac, 48 to 63 Hz	B	7/10 lbs (3,2/4,5 kg)	\$165	05—\$10 28—\$10
6348A	0 to 36 V at 0 to 1.5 A	3 mV or 0.02%	3 mV or 0.02%	105 to 125 or 210 to 250 V ac, 48 to 63 Hz	C	13/19 lbs (5,9/8,6 kg)	\$225	05—\$10 28—\$10
6354A	0 to 160 V at 0 to 400 mA	0.005%+2 mV	0.005%+1 mV	105 to 125 or 210 to 250 V ac, 48 to 63 Hz	C	13/19 lbs (5,9/8,6 kg)	\$259	05—\$10 28—\$10
6357A	0 to 320 V at 0 to 200 mA	0.005%+2 mV	0.005%+1 mV	105 to 125 or 210 to 250 V ac, 48 to 63 Hz	C	13/19 lbs (5,9/8,6 kg)	\$259	05—\$10 28—\$10

\*Refer to page 469 for descriptions.

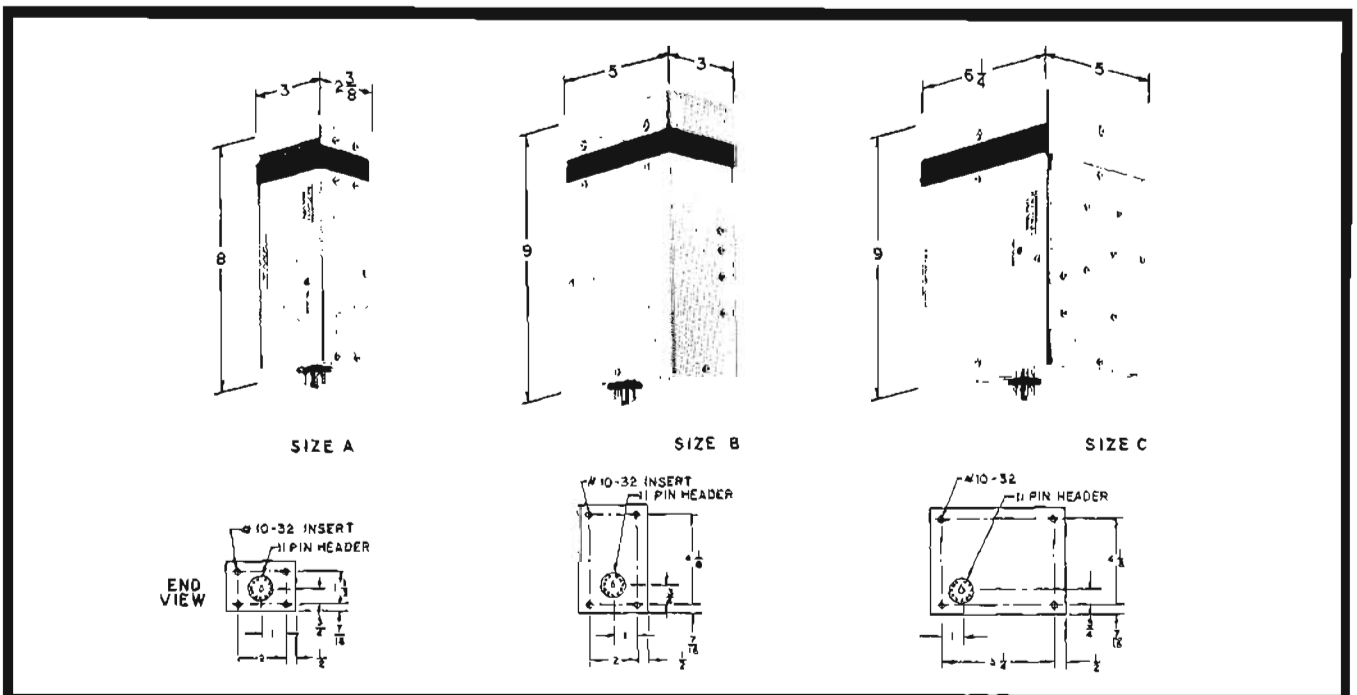

**MOD SERIES**  
Modular plug-in supplies  
Models 6343A-6357A



**DC POWER SUPPLIES**

**Specifications, all models**

**Ripple and noise:** less than 1 mV rms for any combination of line voltage, output voltage and load current.

**Operating temperature range:** 0°C to 50°C (70°C for 6354A and 6357A).

**Temperature coefficient:** less than 0.033%, plus 2 mV/°C.

**Stability:** less than 0.1% plus 10 mV total drift for 8 hours (after 30 minutes' warm-up) at a constant ambient.

**Transient response:** less than 50 μsec is required for output voltage recovery to within 10 mV of the nominal output voltage following a full-load change in output current.

**Remote error sensing and remote programming:** sensing terminals are brought out through the header pins; for local sensing, these terminals are strapped to the output terminals; for remote sensing, leads are connected from the sensing terminals to the remote load terminals; the output voltage is determined by the value of resistance connected between terminals 1 and 2, 1 V out for each 200 ohms connected between these terminals (300 ohms for 6354A and 6357A).

**Programming accuracy:** 5%.

**Cooling:** convection cooling is employed.

**Finish:** light gray.

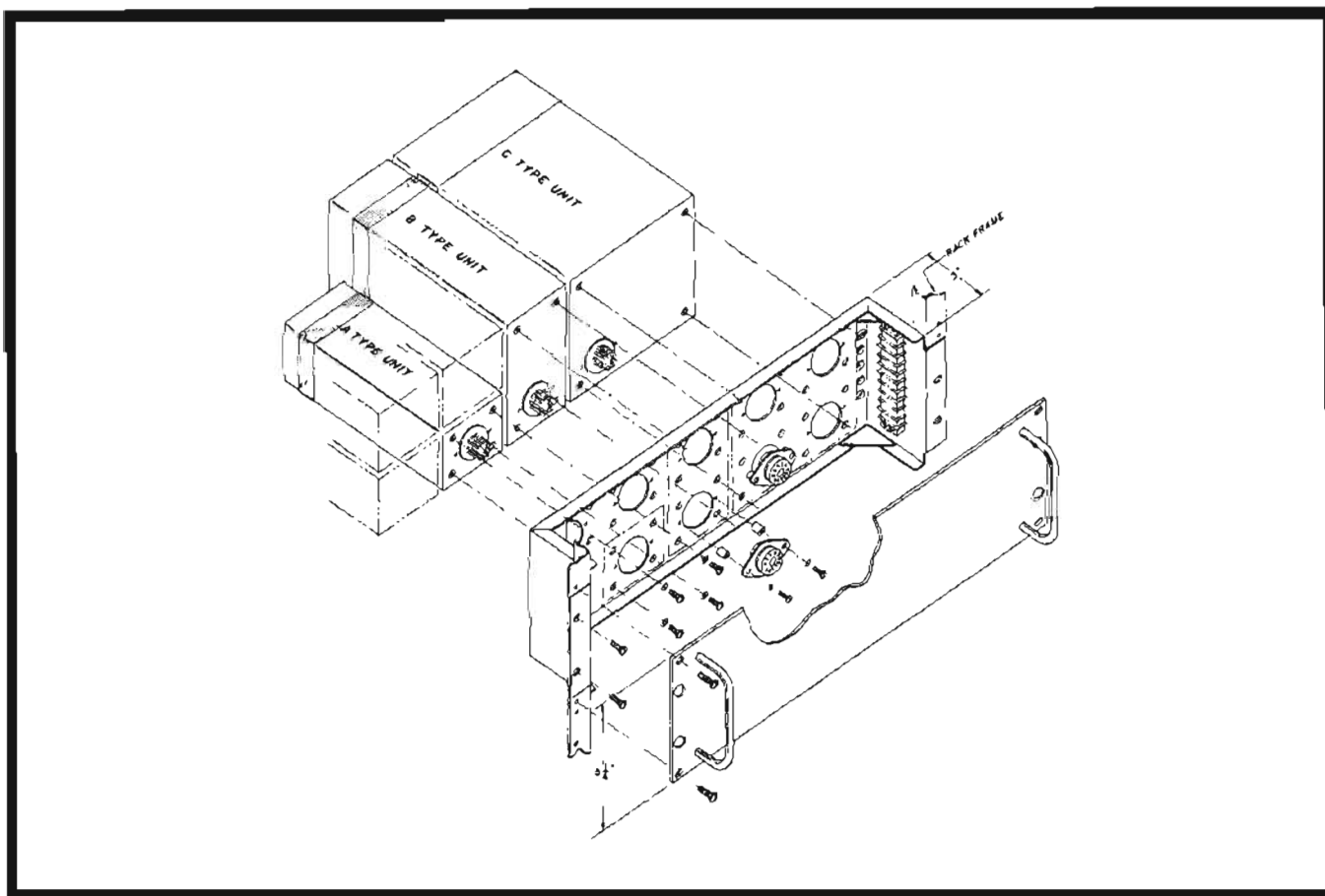

**Efficient rack mounting**

Dimensions and efficient mounting techniques are shown in the illustration for MOD Series plug-in supplies.

The drawing shows 14505A rack mounting assembly; 14503A is similar except for height—3 1/2" (88 mm) instead of 5 1/4" (133 mm)—and the fact that it has holes for six 11-pin sockets. Whereas 14505A can accommodate "A", "B" or "C" size units as shown, the 3 1/2" high rack mounting assembly can only accommodate "A" and "B" size units. On the 3 1/2" panel these "A" and "B" size modules are rotated 90 degrees along the longest axis as compared with this drawing.

**Part No. 14503A:** 3 1/2" high (88 mm) assembly capable of accommodating up to six "A" size modules or one "B" and four "A" modules, or two "B" and two "A" modules, or three "B" modules.

**Price:** 14503A, \$19.

**Part No. 14505A:** 5 1/4" high (133 mm), 19" wide (483 mm) rack assembly for accommodating up to 10 "A" size modules or any combination of "A", "B" and "C" size modules having the same equivalent mounting area as 10 "A" modules.

**Price:** 14505A, \$29.

# DC POWER SUPPLIES



## SLOT SERIES

Fixed dc output — adjustable within  $\pm 10\%$  band  
Models 60065A-60285A

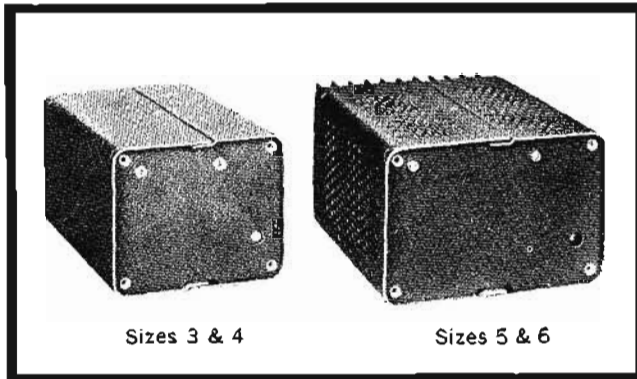

Sizes 3 & 4

Sizes 5 & 6

The SLOT series of modular power supplies are intended for applications requiring a fixed constant voltage source of dc. Output voltage is adjustable to  $\pm 10\%$  of the nominal.

The mechanical and electrical design have been accomplished with a view toward simplicity, without any compromise in component quality or manufacturing technique. The result is a low cost, yet reliable power supply which can be bolted directly to standard rack panels (with only four screws) or included as a power module in a larger chassis. All supplies are fully rated to  $50^\circ\text{C}$ , and require no additional heat sinks.

A temperature compensated zener diode is employed as the reference element in an all-silicon series regulator feedback circuit which monitors and controls the output voltage. The resulting low ripple and low output impedance permit these supplies to be used in critical applications where less well regulated supplies are not suited.

All supplies are short circuit proof and will not be damaged by any overload regardless of how long imposed. The output is floating—thus any supply can be used as either a positive or negative source.

### Specifications

**Load regulation:** less than 0.05% from no load to full load.

**Line regulation:** less than 0.05% from 105 to 125 V ac.

**Ripple and noise:** less than 1 mV rms.

**Temperature coefficient:** output voltage change per  $^\circ\text{C}$  is less than 0.025%.

**Stability:** the total drift for eight hours (after 30 minutes warmup) at a constant ambient is less than 0.1%.

**Temperature rating:** operating: 0 to  $50^\circ\text{C}$ ; storage:  $-40$  to  $+85^\circ\text{C}$ .

**Output impedance:** less than 0.5 ohms to 100 kHz; less than 5 ohms to 1 MHz.

**Transient recovery time:** less than 25  $\mu\text{s}$  for output voltage recovery to within 10 mV of the nominal output voltage following a full load or 5 amp load change, whichever is less.

**Overload protection:** the output is current limited (non-adjustable) and is fully rated for operation under any overload condition including a direct short circuit, regardless of how long maintained. Supply will automatically restore to normal operation upon overload removal.

**Terminals:** a rear barrier strip includes AC, ACC, GND, + Out, - Out, + Sensing, and - Sensing terminals. Either side of the supply may be grounded or the output may be operated floating at potentials of up to 300 V off ground.

**Output control:** screwdriver adjust, accessible through hole in end plate.

**Mounting:** four 8-32 threaded nuts embedded in mounting end plate facilitate assembly of modules to rack panels, chassis, etc.

**Option 27:** 208 V ac input. Price on request.

**Option 28:** 230 V ac input. Price on request.

Size	Dimensions (inches)	Dimensions (cm)
Size 3:	3 $\frac{1}{4}$ " (8.6 cm) x 4 $\frac{1}{4}$ " (10.5 cm)	6" (15.2 cm)
Size 4:	3 $\frac{1}{4}$ " (8.6 cm) x 5 $\frac{1}{4}$ " (13 cm)	6" (15.2 cm)
Size 5:	3 $\frac{1}{4}$ " (8.6 cm) x 5 $\frac{1}{4}$ " (13 cm)	7-5/16" (18.6 cm)
Size 6:	4 $\frac{1}{4}$ " (10.8 cm) x 5 $\frac{1}{4}$ " (13 cm)	11" (27.9 cm)

	Net	Shipping
Size 3:	2.5 lb. (1.1 kg)	4.0 lb. (1.8 kg)
Size 4:	4.5 lb. (2 kg)	6.5 lb. (2.9 kg)
Size 5:	6.0 lb. (2.7 kg)	8.0 lb. (3.6 kg)
Size 6:	13 lb. (5.9 kg)	15 lb. (6.8 kg)

### Stock models:

Model	80085A	80122A	80126A	—	80244A	80286A
Output	DC Voltage 6 V $\pm 10\%$ DC Current 0-3.5A	12 V $\pm 10\%$ 0-1A	12 V $\pm 10\%$ 0-2.2A	—	24 V $\pm 10\%$ 0-1A	28 V $\pm 10\%$ 0-1.5A
Input	105-125 V ac 48-440 Hz	1.5A	0.8A	1.3A	—	1A
Size	5	3	5	—	4	5
Price	1 - 9 \$100	10 - 19 \$ 97	20 - 49 \$ 94	1 - 9 \$100	10 - 19 \$ 97	20 - 49 \$ 94

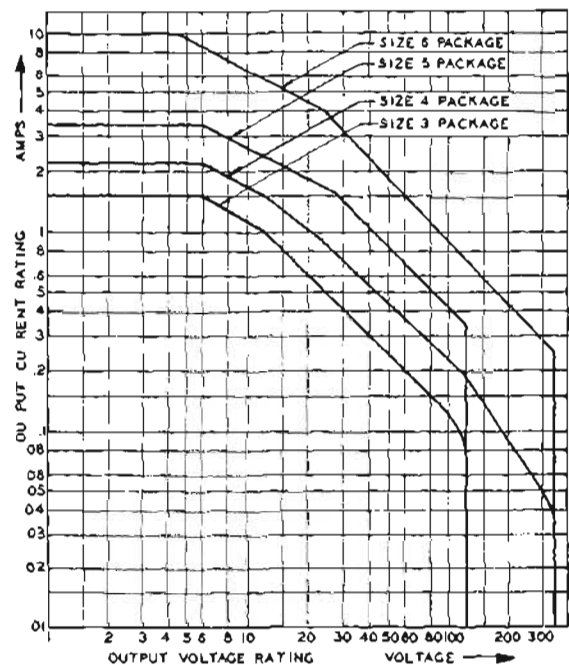

The above chart indicates the maximum output current and voltage available for any size module. The area below and to the left of each curve includes all available ratings for that size module. In quantities of 20, the prices for typical ratings in each of the package sizes are:

Size 3, \$74; size 4, \$83; size 5, \$94; size 6, \$169. For an exact price and delivery quotation, contact your nearest Hewlett-Packard field sales office, giving desired output voltage, current, and quantity.

## STRAIN GAGE

Extreme isolation & versatile medium voltage  
Models 801C and 711A, 712B



## DC POWER SUPPLIES

Designed to operate primarily as a power supply for strain gage applications, the 801C is a solid-state power supply whose design, construction and size permit extreme isolation from ground and the ac power line . . . greater than 10,000 megohms to ground or ac input and less than 1 pF capacity from output terminals to input power line.

Using many supplies to feed a large number of strain gages provides excellent isolation capabilities, and the shorting of a single strain gage will not disrupt the entire test setup.

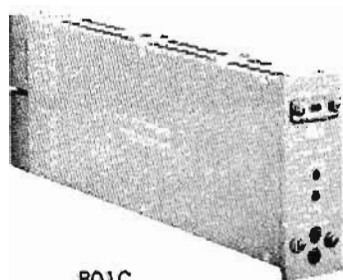

801C

### Specifications

- Output:** 0 to 25 volts at 0 to 0.2 amp.
- Load regulation:** less than 2 mV change, no load to full load.
- Line regulation:** less than 2 mV change, for a change in line voltage from 105 to 125 volts.
- Ripple and noise:** less than 100  $\mu$ V rms.
- Maximum ambient operating temperature:** 50°C.
- Stability:** less than 0.1%  $\pm$  5 mV total drift for 8 hours after 30-minute warmup.
- Overload protection:** current limiter protects supply from all overloads including direct shorts.
- Controls:** coarse and vernier for continuous voltage control.
- Remote error sensing:** at rear terminals.
- Power:** 105 to 125 V ac, 55-65 Hz.
- Dimensions:** 5" high, 14 $\frac{7}{8}$ " deep, 1 $\frac{1}{8}$ " wide.
- Weight:** net 4 lbs; shipping 8 lbs.
- Price:** 1 to 9, \$149 each; 10 to 49, \$145 each; 50 to 99, \$140 each; 100 and more, \$135 each.

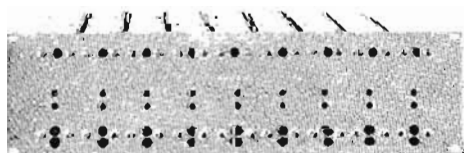

14500A Rack Mounting Panel—\$18.00

### Rack mounting panel

This panel (5 $\frac{1}{4}$ " high x 19" wide) permits nine 801C modules to be rack-mounted side by side. All necessary hardware for mounting nine supplies is included. Provision is made on this panel for a label for each power supply. This label receives rear illumination from the pilot light when ac power is applied.

These easy-to-use general purpose, low-power medium-voltage laboratory supplies are particularly suitable for experimental setups and other medium-voltage bench applications. These instruments are designed for high regulation and low ripple. The 711A contains a 0-500-volt dc output at 100 mA along with an unregulated ac filament output, while the 712B contains four outputs—0-500 volts at 0-200 mA, 0 to -150 volts at 5 mA, -300 volts at 50 mA, and an unregulated ac filament source.



711A

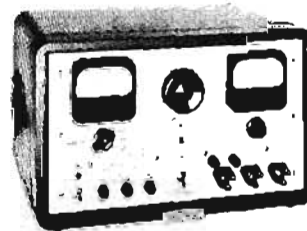

712B

### Specifications 711A supply

- Outputs:** 0 to 500 volts dc, 0 to 100 milliamps, 6.3 volts rms at 6 amps or 12.6 V rms CT at 3 amps unregulated.
- Load regulation:** less than 0.5% change or 1 volt change from no load to full load.
- Line regulation:** less than 0.5% change or 1 volt change for  $\pm$ 10% line voltage change.
- Ripple and noise:** less than 1 mV rms.
- Input:** 115 or 230 volts  $\pm$  10%, 50 to 1000 cycles, approx. 145 watts.
- Dimensions:** 7 $\frac{3}{8}$ " (18.7 cm) wide x 11 $\frac{1}{2}$ " (31.5 cm) high x 14 $\frac{1}{4}$ " (38 cm) deep.
- Weight:** 20 lbs (9.2 kg) net; 26 lbs (11.8 kg) shipping.
- Price:** \$275.
- Option 2B:** rewire for 230 V single phase ac input: Supply as normally shipped is wired for 115 V ac input, and must be internally reconnected for 230 V ac. Price, \$10.

### Specifications 712B supply

- Outputs:**
  - DC regulated high voltage, 0 to +500 volts, 0 to 200 mA.
  - DC regulated fixed bias, -500 volts, 0-50 mA.
  - DC variable bias, 0 to -150 volts 0-5 mA.
  - AC unregulated voltage, 6.3 volts CT, 0-10 amps.
- Load regulation:**
  - DC regulated high voltage: less than 50 mV change, no load to full load.
  - DC regulated fixed bias: less than 50 mV change, no load to full load.
  - DC variable bias: tied to fixed bias. Hence, source regulation is same as fixed bias plus an internal impedance of 0-1000 ohms.
- Line regulation:** less than  $\pm$  100 mV for a  $\pm$ 10% line voltage change.
- Ripple and noise:** less than 500  $\mu$ V.
- Input:** 115 volts  $\pm$  10%, 50 to 60 cycles
- Dimensions:** 20 $\frac{3}{4}$ " (56.9 cm) wide x 12 $\frac{3}{4}$ " (34.9 cm) high x 14 $\frac{3}{4}$ " (40.4 cm) deep.
- Weight:** 70 lbs (31.7 kg) net; 81 lbs (36.7 kg) shipping.
- Price:** \$490.

# DC POWER SUPPLIES



## KLYSTRON POWER SUPPLIES

Versatile power sources for many klystrons  
Models 715A, 716B

The HP 716B Supply offers superior regulation, noise, ripple and hum characteristics, plus the broad capability of powering at least 250 types of klystrons. Beam and reflector voltages are closely regulated and continuously adjustable, using calibrated controls accurate to within  $\pm 2\%$  on beam voltage and to within  $0.5\% \pm 1$  volt on repeller voltage. In addition, a regulated dc filament supply minimizes residual FM and AM from the klystrons.

The reflector supply can be internally modulated with a sawtooth for FM or with a square wave for on-off operation. The positive excursion of the square wave is clamped to the reflector voltage, simplifying setup and minimizing double moding. Sawtooth and external modulation are ac-coupled to the reflector. A protective diode prevents the klystron reflector voltage from becoming positive with re-

spect to the cathode. Special circuitry eliminates turn-on transients that could be harmful to the klystron. Relays disconnect the beam supply to prevent klystron failure should the filament voltage drop below 1 volt or rise above 9 volts. The filament circuit in the 716B is protected against voltage surges up to 800 volts. These relays also disconnect the supplies whenever a klystron filament short circuits.

The HP 715A, designed to operate many types of low-power klystrons, offers a regulated 250-to-400 volt beam voltage, a 0-to-900 volt regulated reflector supply and a 6.3 volt ac filament supply. The reflector supply can also be square-wave modulated internally at the nominal frequency of 1000 Hz, externally modulated or sine-wave modulated at the power line frequency. Klystron protection is built in.

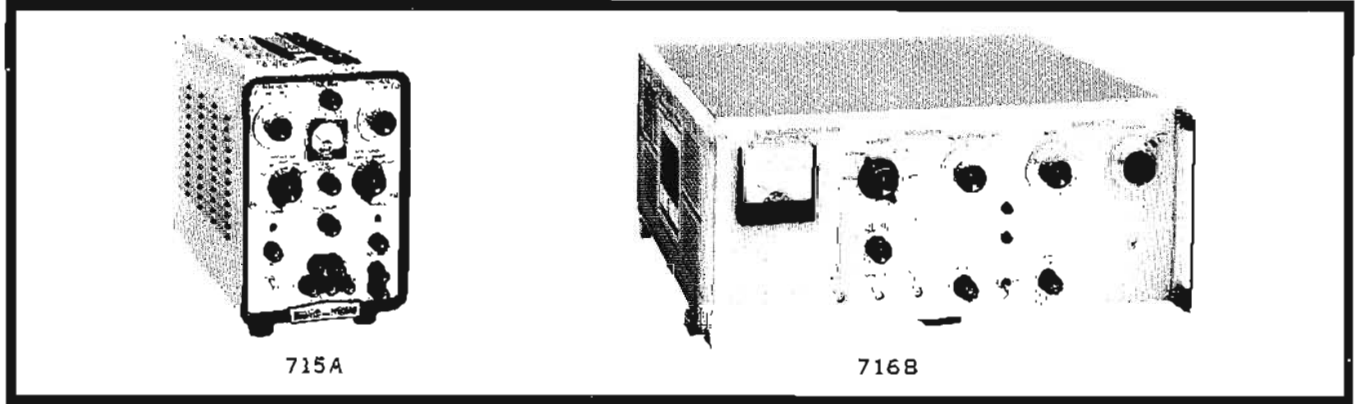

Specifications, 715A

Specifications, 716B

Reflector supply	0 to 900 V neg. with respect to beam supply, calibrated voltage controls; regulation within 1% $\pm 10\%$ line voltage variation; ripple $< 10$ mV; $10 \mu\text{A}$ max.	0 to 800 V neg. with respect to beam supply, accuracy $\pm 0.5\%$ of dial reading $\pm 1$ V, line regulation better than 0.05%; ripple $< 500 \mu\text{V}$
Beam supply	250 to 400 V negative with respect to chassis ground, calibrated voltage controls; current 30 mA max. at 250 V, 50 mA max. at 400 V; regulation better than 1%, no load to full load or for $\pm 10\%$ normal line voltage variation; ripple less than 7 mV	250 to 800 V negative with respect to chassis ground, accuracy $\pm 2\%$ of dial reading; current 100 mA max.; line regulation better than 0.1%; load regulation better than 0.05%; ripple less than 1 mV
Filament supply	6.3 V ac, 1.5 amp maximum	6.3 V dc, adjustable nominally between 5 and 9 volts, isolated from ground; current 0 to 2 amps; 2 amps max. available to 6.5 V, decreasing to approx. 150 mA at 9 V, ripple $< 2$ mV; line regulation better than 1% with $\pm 10\%$ line change
Internal modulation	square wave: 1000 $\pm 100$ Hz, adjustable; 0 to 110 V p-p, negative from reflector voltage; less than 10 $\mu\text{sec}$ rise and decay times; sinusoidal power line frequency, 0 to 350 V p-p	square wave: 400 Hz to 2.5 kHz; 0.1% short-term stability; 10 to at least 150 V p-p, negative from reflector voltage; 5 $\mu\text{sec}$ rise time; external sync of internal square wave 10 V peak, 500 k $\Omega$ nominal input impedance; sawtooth: 75 Hz nominal, 0 to at least 150 V nominal p-p, ac-coupled to reflector
External modulation	terminals provided; input impedance 100 k $\Omega$	max. input 200 V p-p; input impedance 500 k $\Omega$ , 100 pF nominal
Oscilloscope output		with internal square-wave modulation: 1 V p-p min. for scope sync, 600 ohms output impedance; with internal sawtooth modulation: 10 V p-p min. for scope sweep, 50 k $\Omega$ output impedance
Meter	monitors beam current 0 to 50 mA	monitors beam current 0 to 100 mA
Power	115 V $\pm 10\%$ , 50 to 60 Hz, 200 W	115/230 V switch $\pm 10\%$ , 50 to 60 Hz, 200 to 350 W
Dimensions	7 $\frac{3}{8}$ " wide, 11 $\frac{1}{2}$ " high, 13 $\frac{3}{4}$ " deep (187 x 292 x 349 mm)	16 $\frac{1}{2}$ " wide, 6-25/32" high, 16 $\frac{3}{4}$ " deep (425 x 172 x 416 mm); hardware furnished for rack mounting
Weight	net 19 lbs (8.6 kg); shipping 24 lbs (10.8 kg)	net 46 lbs (20.7 kg); shipping 62 lbs (28.3 kg)
Accessories furnished	715A-16C shielded output cable, for connection to klystron	6' cable, terminated end mates with 716B (one furnished with instrument) HP Stock No. 00716-61601, \$25
Price	HP 715A*, \$365; add \$10 for 230 V, 50 to 60 Hz input	HP 716B, * \$875

\*Manufactured by Yokogawa, Hewlett-Packard Ltd., Tokyo

**PS/A SERIES**  
DC power supply/amplifier  
Models 6823A, 6824A



**DC POWER SUPPLIES**

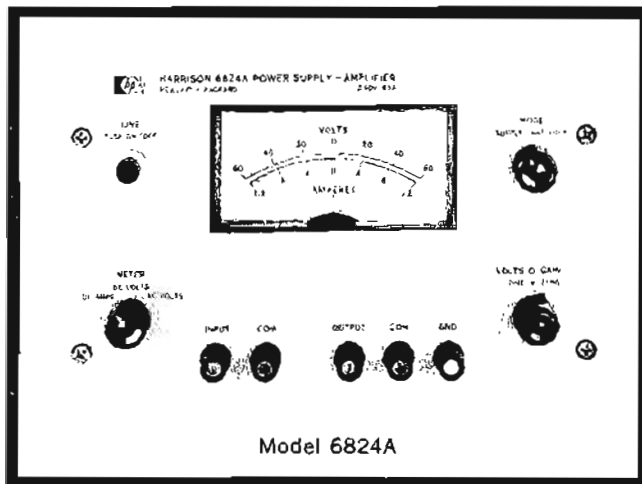

Model 6824A

Models 6823A and 6824A are dual-purpose dc regulated power supplies and direct-coupled amplifiers. Two or more of these units can be connected in Auto-Series to obtain greater voltage capability. High speed constant current operation can be obtained by simply adding an external resistor in series with the load and making minor changes in the rear barrier strapping.

Two temperature-compensated zener diodes are employed as reference elements in a series regulator feedback circuit which monitors and controls the output voltage. The resulting low ripple and low output impedance permit these instruments to be used in critical power supply applications. Low internal dissipation assures reliability.

As a power amplifier, the 6823A offers a signal-to-noise ratio of 80 dB at full output with low distortion and 20 dB gain from dc-20 kHz (kc); making it useful in a wide variety of applications. The output is inverted. Rack mounting hardware is available for mounting singly or in pairs in 3½" of rack space.

### Advantages:

#### Power supply

- Output adjustable through zero
- High-speed programming
- Short-circuit-proof
- Low ripple and noise
- Fast transient recovery
- No overshoot for turn-on, turn-off, or power removal

#### Power amplifier

- Variable gain
- High signal-to-noise ratio
- Low distortion
- Frequency response — dc to 20 kHz

### Applications

As a dc Power Supply, Models 6823A or 6824A can be controlled from the front panel, or remotely programmed with resistance or voltage. The low output drift and noise combined with high speed programming adapt this supply to a wide variety of laboratory and production testing applications.

As a dc coupled Power Amplifier, the unusually low output impedance, distortion, ripple and noise make the 6823A or 6824A useful in servo system, as a pulse or oscillator amplifier, and for motor control. Constant Current output is readily achieved by connecting a current monitoring resistor to the rear terminal barrier strip—makes an ideal driver-amplifier for deflection coils!

For more information, refer to Application Note 82, Power Supply/Amplifier Concepts and Modes of Operation, free of charge from your local Hewlett-Packard field sales office.

### Specifications

MODEL 6823A	
High speed programming dc power supply	10 watt peak output dc power amplifier
Output: -20 to +20 V dc @ 0-0.5 a	Output: 40 volts p-p @ 0-0.5 a
Load regulation: 0.02% + 5 mV	Voltage gain: Variable 0-10 (20 dB) output inverted.
Line regulation: 0.02% + 5 mV	Frequency response: at full output, $\pm 3$ dB from dc to 20 kHz.
Ripple & noise: 2 mV rms	Max. phase shift: dc -180° 100 Hz -181° 1 kHz -183° 10 kHz -205° 20 kHz -225°
Transient recovery time: less than 100 $\mu$ sec to within 5 mV + 0.02% of the nominal output.	Distortion: <0.02% at 1 kHz and full output.
Remote programming: 500 ohms/V. Also voltage programming.	Input impedance: 2k ohms approx.
Programming speed: less than 50 $\mu$ sec are required for programming between -20 V and +20 V. Typically, the programming time between 10% and 90% of the maximum voltage span is 15 $\mu$ sec.	Input terminals: front and rear.
AC input: 105-125/210-250 V ac, single phase, 50-440 Hz; 0.33 amp, 24 watts max. Meter: Dual purpose with selector switch; -24 to +24 volts, -0.6 to +0.6 amps. Size: 3½" H x 8¾" W x 13" D (8.9 cm H x 21.8 cm W x 33 cm D). Weight: 16 pounds (7.26 kg) net, 20 pounds (9.07 kg) shipping. Price: \$194. Rack mounting kits: refer to HVB Series (P472) for details. 14513A: mounts one 3½" high unit—add \$20.00 14523A: mounts two 3½" high units—add \$10.00	
MODEL 6824A	
High speed programming dc power supply	50 watt peak output dc power amplifier
Output: -50 to +50 V DC @ 0-1.0 A	Output: 100 volts p-p @ 0-1.0 A
Load regulation: 0.02% + 5 mV	Voltage gain: variable, 0-10 (20 dB), output inverted.
Line regulation: 0.02% + 5 mV	Frequency response: At full output, $\pm 3$ dB from dc to 20 kHz
Ripple & noise: 10 mV rms.	Max. phase shift: dc -180° 100 Hz -180.7° 1 kHz -182.9° 10 kHz -205° 20 kHz -225°
Transient recovery time: less than 100 $\mu$ sec to within 5 mV + 0.02% of the nominal output.	Distortion: <0.02% at 1 kHz and full output
Remote programming: 500 ohms/V. Also voltage programming.	Input impedance: 2k ohms approx.
Programming speed: less than 50 $\mu$ sec are required for programming between -50 V and +50 V. Typically, the programming time between 10% and 90% of the maximum voltage span is 15 $\mu$ sec.	Input terminals: front and rear.
AC input: 105-125/210-250 V ac, single phase, 50-60 Hz, 1.3 amps, 96 watts max. Meter: triple purpose with selector switch; -60 to +60 volts. -1.2 to +1.2 amps. 0 to 60 V rms Size: 5½" H x 8¾" W x 13" D (14 cm H x 21.8 cm W x 33 cm D). Weight: 17 pounds (7.7 kg) net, 21 pounds (9.55 kg) shipping. Price: \$350 Rack mounting kits: refer to HVB Series (p472) for details. 14515A: mounts one 5½" high unit—add \$23.00 14525A: mounts two 5½" high units—add \$13.00	

### Other specifications for both models

**Temperature ratings:** operating: 0 to 50°C. Storage +20 to 85°C.

**Temperature coefficient:** 0.015% + 1 mV per °C.

**Stability:** 0.075% + 5 mV for 8 hrs. (after ½ hr. warm-up); ambient temperature variation held to 3°C.

**Overload protection:** the unit is completely protected for all overload conditions including a short circuit applied directly across the output terminals.

**Output terminals:** both front and rear terminals are provided.

**Option 28:** rewire for 230 V ac input. Unit as normally shipped is wired for 115 V ac input, and must be internally reconnected for 230 V ac operation. Add \$10 to price.





Electronic counters have proven to be the most accurate, flexible, and convenient instruments available for making both frequency and time interval measurements. Since the introduction of the first high-speed counter (the 10 MHz HP Model 524A), more than 15 years ago, Hewlett-Packard has developed a broad range of both vacuum tube and solid-state counters with a wide variety of features. Many vacuum tube models are still available, but they have generally been superseded by the solid state line of counters. The counters and associated equipment can measure frequencies from 0 cycles per second to 40 GHz, and time intervals from 10 nanoseconds to more than 100 days.

An electronic counter is an instrument for comparing an unknown frequency or time interval to a known frequency or a known time interval. The counter's logic is designed to present this information in an easy-to-read, non-ambiguous, numerical display. The accuracy of this measurement depends primarily upon the stability of the known frequency, which is derived from the counter's internal oscillator. The oscillators in HP counters are designed and built by HP and have excellent stability (both long-term and short-term). All Hewlett-Packard counters are engineered for maximum reliability, accuracy and ease of operation.

The decision as to which electronic counter is best suited for a specific application depends upon the range and type of measurements to be made. See Electronic Counter Selection Guide (page 498). Hewlett-Packard has a broad line of counters with wide ranges of maximum frequency capability, accuracy, resolution and flexibility.

With this very complete line of electronic counters Hewlett-Packard also offers many input and output devices for these instruments. Included in the available accessory instruments are: digital recorders for automatic recording of counter measurements, digital clocks which control measurement intervals and supply information for simultaneous recording, digital-to-analog converters for obtaining analog records of digital measurements, and scanners for receiving the outputs from several electronic counters for display into a single recording device. Hewlett-Packard also manufactures magnetic and optical tachometers for rps measurement inputs to low-frequency electronic counters, and

to frequency meters such as the HP 5210A/B.

### Counter elements

The electronic counter has several basic functional sections which can be interconnected in a wide variety of ways for making different types of measurements. Of these, the most important functional sections are: (1) the decade counting assemblies (DCA's) with numerical displays to totalize and display the count; (2) the signal gate, which controls count start and stop with respect to time, and (3) the time base, which supplies the precise increment of time to control the gate for a frequency or pulse train measurement. Other sections include: signal shaping, display control, logic control and binary coded decimal (BCD) output. The logic control interconnects the proper circuits for the desired measurement, selects the appropriate measurement units for display and initiates the measurement cycle. The various modes of electronic counter operation are described in the following paragraphs, and accuracy is discussed on page 497.

### Totalizing

Electronic counters can be operated in a totalizing mode with the main gate

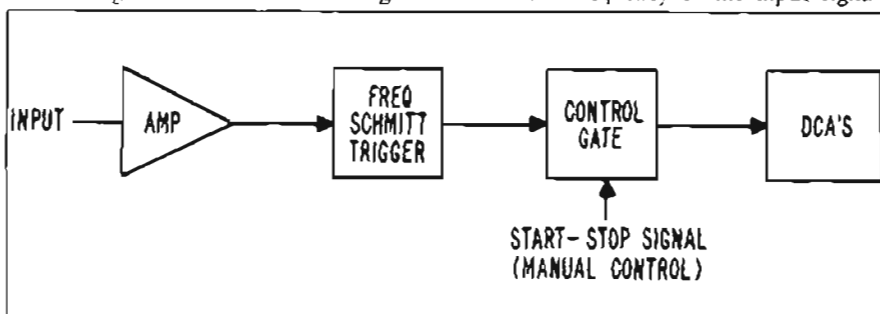

Figure 1. Function switch set to manual Start and Stop to determine interval for totalizing input signal.

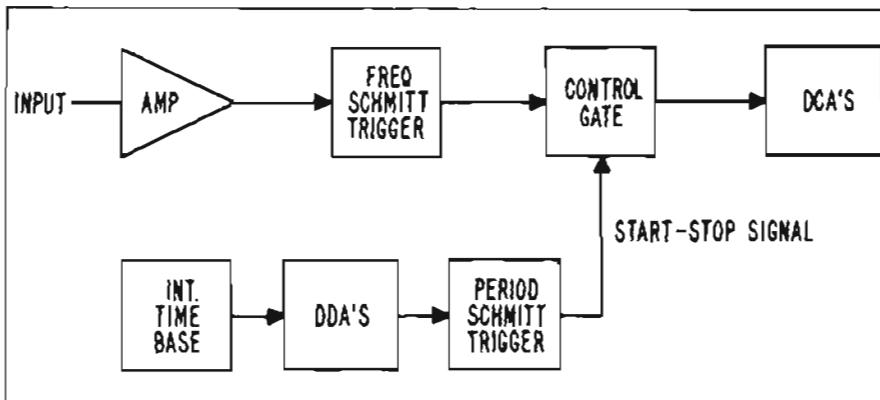

Figure 2. Function switch set to Frequency and gate time selected by time base switch.

flip-flop controlled by the manual start-stop switch as shown in Figure 1. With the switch in Start, the decimal counter assemblies totalize the input pulses until the main gate is closed by the switch being changed to Stop. The counter display then represents the input pulses received during the interval between manual Start and manual Stop. The unique feature of a Reversible Counter is each decade's ability to totalize in either a positive or negative direction. Signals on one input line are added, while signals on the other input line are subtracted; alternately, signals on the first input line may be added or subtracted, where information regarding the direction of count is supplied to the second input line. The HP 5280A can reverse its direction of count in 250 nsec.

### Frequency measurements

For direct frequency measurements, the input signal is first supplied to a signal shaper which converts the input signal (CW or pulses) to uniform pulses. The output of the shaper is then routed to decade counting assemblies (DCA's) through a gate controlled by the counter's time base as shown in Figure 2. The number of pulses totalized in the DCA's for the selected period of time represents the frequency of the input signal.

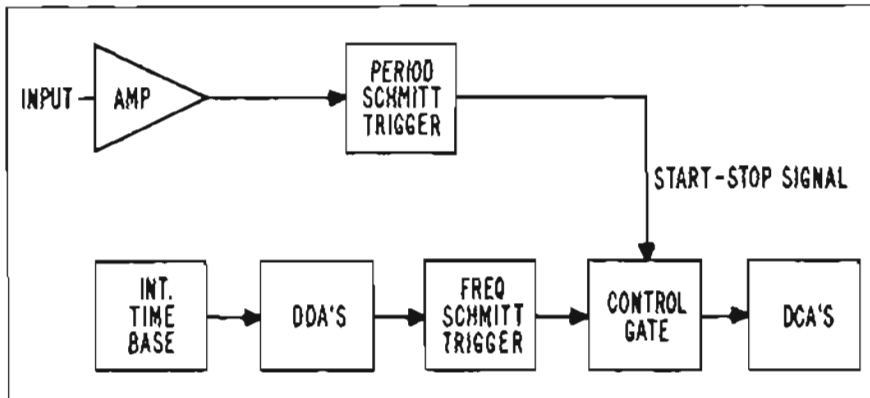

Figure 3. Function switch set to Period and counted frequency selected by time base switch.

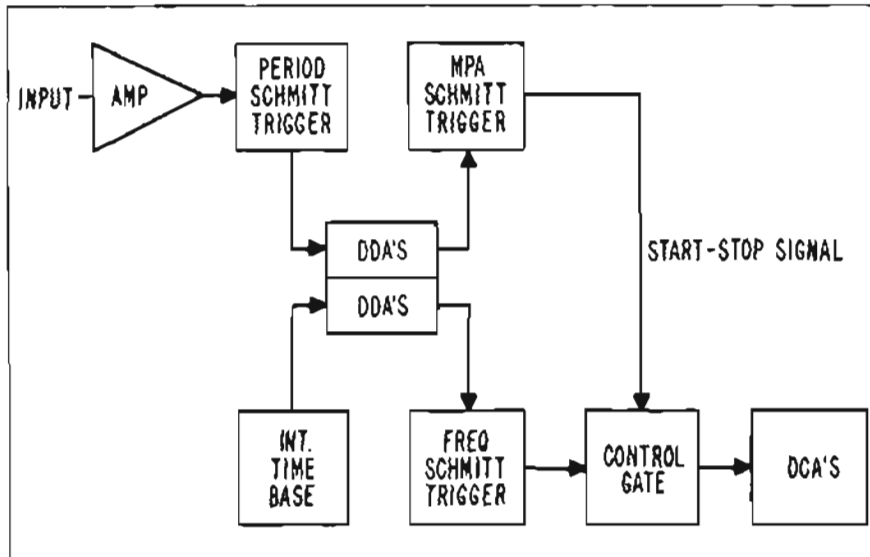

Figure 4. Function switch set to Period Average. Input signal controls gate for counting time base frequency.

The frequency counted is displayed on a numerical readout, with a positioned decimal point, and is retained until a new sample is taken. The Sample Rate control determines the display time of the frequency measurement being made and initiates counter reset and the next measurement cycle.

The time base selector switch selects the gating interval, positions the decimal point and selects the appropriate measurement units. It should be mentioned that the new 5210A Frequency Meter, although not an electronic counter, allows frequency measurements to an accuracy of 1% of reading on a special log linear scale. (to 0.2% with calibrated offset option).

### Period measurements

Period measurements are made with the counter functions arranged as shown in Figure 3. The unknown input signal controls the gate time, and the time base frequency is counted in the DCA's. The input shaping circuit selects the positive-going zero axis crossing of successive cycles as trigger points for opening and closing the gate.

Period measurements allow more ac-

curate measurements of unknown low-frequency signals because of increased resolution. For example, a frequency measurement of 100 Hz on the 5245L, with a 10-second gate time will be displayed as 0000.1000 kHz. A single period measurement of 100 Hz on an HP 5245L with 10 MHz as the counted frequency, would be displayed as 0010000.0  $\mu$ sec. Thus, resolution is increased by a factor of 100. The accuracy here is also affected by the  $\pm 1$  count ambiguity  $\pm$  the time base accuracy  $\pm$  the trigger error. (Accuracy is discussed on Page 497.)

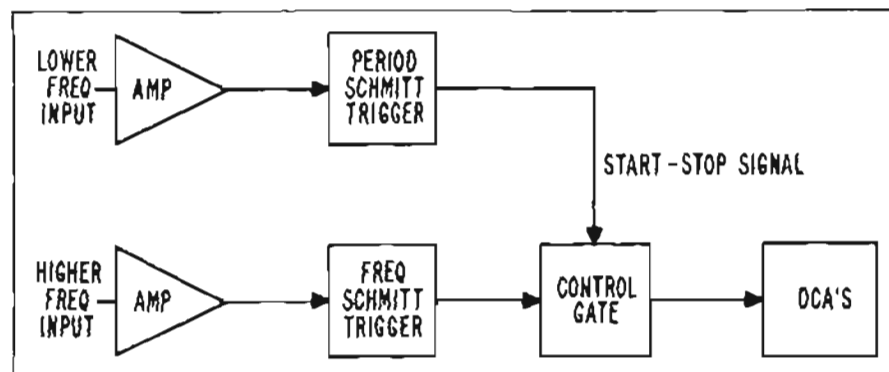

Figure 5. Function switch set to Period and time base switch to Ext. Lower frequency serves as gate control, while higher frequency replaces time base as counted frequency.

### Multiple period averaging

The effect of the  $\pm 1$  count ambiguity and trigger error can be minimized by multiple period averaging (Figure 4). In the HP 5245L, for example, the function selector switch is ganged to the decade divider assemblies (DDA's) so the input signal may be scaled in decade steps by factors up to 100,000 to reduce trigger error. The  $\pm 1$  count ambiguity is also reduced by a factor of 10 for each decade of scaling selected for the input signal. In the low-frequency measurement example above, the counter would display 10000.000  $\mu$ sec for a 100 period average. (The function selector switch automatically shifts the decimal point in the display to show the correct reading for a single period.)

### Ratio measurements

The ratio of two frequencies is determined by using the lower frequency signal for gate control while the higher frequency signal is counted, as shown in Figure 5. With proper transducers, ratio measurements may be applied to any phenomena which may be represented by pulses or sine waves. Gear ratios and clutch slippage, as well as frequency divider or multiplier operation, are some of the measurements which can be made using this technique.

Accuracy is  $\pm 1$  count  $\pm$  trigger error. The accuracy may be improved by using the multiple period averaging technique discussed above.

### Rate measurements

With a preset counter or a counter with a preset plug-in, frequency measurements can be normalized automatically to rate measurements by appropriate selection of the gate time. The counter will then display a readout corresponding to the desired engineering units. For example: the HP 5214L Preset Counter or the HP 5245L Counter with HP 5261A Preset Plug-in can be set to a gate time of 600 milliseconds to cause an input from a 100-pulse-per-revolution tachometer to be displayed directly in revolutions per minute.

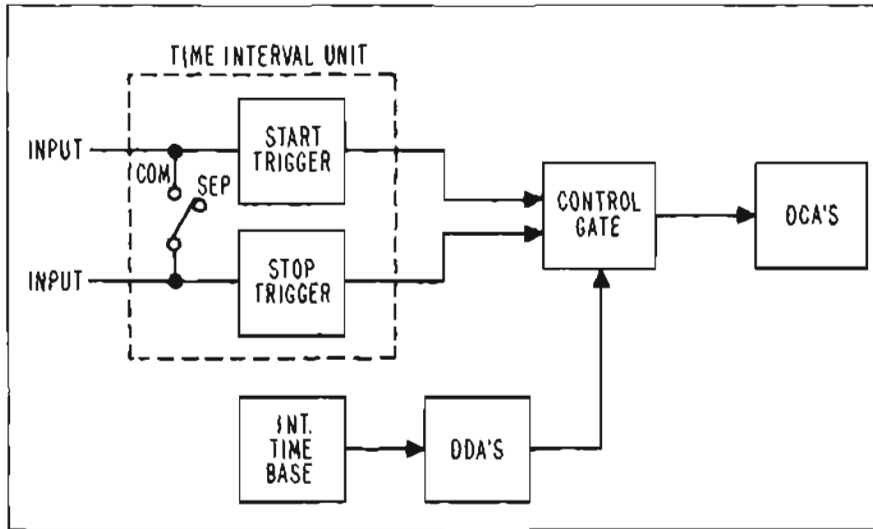

Figure 6. Start and stop signals derived from two sources or from different points of same waveform as selected by Com-Sep switch.

**Scaling**

The HP 5245L Solid-state Counter may be used for scaling (dividing down) an input by a factor of 10<sup>n</sup>. In this mode of operation, the input is routed through the decade dividers with the scaled output available from the rear of the counter. N is an integer varying from 1 to 9, selectable at the rear panel.

**Time interval measurements**

Time interval measurements are similar to period measurements, except that the trigger points on the single waveform or waveforms are adjustable. As shown in Figure 6, separate signals may be used as start and stop signals or, by

switching the Com-Sep switch to "Com," measurements may be made from one point on a waveform to another point on the same waveform. Triggering polarity, amplitude and slope are selected for each channel independently. The time interval is displayed in units of microseconds, milliseconds or seconds. Accuracy is affected by the same factors which affect period measurements.

Extremely short time intervals (10 nanoseconds to 0.1 second) can be measured accurately with the 5275A Time Interval Counter. This instrument, using a 1 MHz external frequency standard, multiplies the 1MHz to 100MHz to obtain

10 nanosecond time increments as the "counted" frequency, which results in exceptionally fine resolution.

Measurement of the time required for a number of random events to occur is possible with the 5214L Preset Counter. This instrument's decade dividers may be preset to close the gate on the Nth input pulse, where N is any number from 1 to 100,000.

**High-frequency measurements**

Accurate high-frequency measurements can be made with an electronic counter by using heterodyne converters, transfer oscillators or automatic dividers.

The unique capabilities of each will now be briefly described.

*Heterodyne converters* measure the average value of CW signals (even when FM'd to a certain extent) and have a resolution of down to 1 Hz in 1 second of counter gate time (HP 5255A; 4 seconds). Hewlett-Packard manufactures a series of heterodyne converter plug-in units (see pages 502, 503) which convert the unknown high frequency to a related frequency which is within the counter's basic range. Measurements to 12.4 GHz are possible.

As an example we shall refer to the HP 5255A Plug-In Unit (see Fig 7). The tuning control selects the 200 MHz harmonic that gives a beat frequency output which, after prescaling by a factor of four, is within the 50 MHz counting capability of the 5245L. At the same time the 5245L gate time is extended by a factor of 4 so that direct readout on the 5245L is achieved. The frequency reading

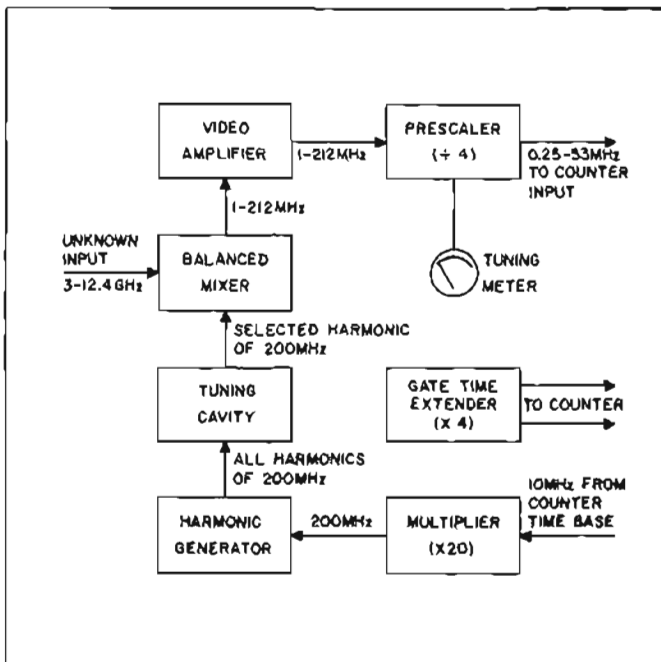

Figure 7. Heterodyne converter measurement (Block diagram of HP 5255A Frequency Converter). Counter measures difference frequency.

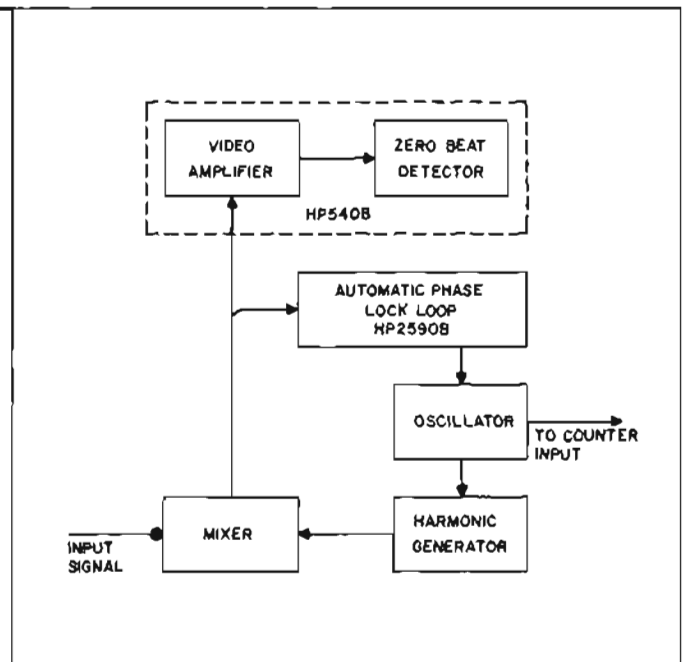

Figure 8. Transfer oscillator measurement. Counter measures oscillator frequency.

on the counter is then added to the setting on the tuning dial to give the unknown frequency.

*Transfer oscillators*, on the other hand, are more versatile. They can measure FM or pulsed signals, as well as CW signals, over a very wide frequency range, can produce N Hz resolution in 1 second counter gate time where N is the harmonic number, but require calculations (and perhaps two measurements) and thus need more operator training and time. Note that accuracy may be less when measuring the carrier frequency of pulsed signals.

In operation, the transfer oscillator generates a variable frequency, which is selected so that a known or determinable harmonic of that frequency zero beats with the unknown CW signal (see Fig. 8). The transfer oscillator frequency is then measured on the counter and multiplied by the harmonic number to give the unknown frequency. In the HP 2590B, zero beat is obtained by an automatic phase lock loop after one of the nearest subharmonics has been manually tuned. Measurements to 15 GHz are possible with the HP 2590B, and to 40 GHz with the HP 540B with related instruments.

*Automatic frequency dividers* provide automatic measurement and direct readout of a wide range of CW frequencies, and furnish 1000 Hz resolution in 1 sec although little FM can be tolerated. Measurements from 0.3 GHz to 12.4 GHz can be achieved using the HP 5260A with a suitable counter. The 5260A zero beats with the input automatically and without offset and then provides an output frequency equal to exactly 1/100 or 1/1000 of the input frequency depending upon the division ratio switch setting.

### Time-base oscillator accuracy

Definition of time base oscillator stability requires knowledge of long-term stability, short-term stability, and the effects of line-voltage and ambient temperature changes.

Long-term stability (also called crystal aging rate or drift rate) refers to slow changes in average frequency with time due to secular changes in the resonator or other elements of the oscillator. This is usually expressed in fractional parts per unit time such as "parts in  $10^8$  per day." The drift rate of a crystal oscillator is predictable after an initial aging-in period and it generally assumes a linear characteristic. The slope of this line is the long-term drift rate of the oscillator. The drift is cumulative. Various methods exist for determining this drift rate and for calibrating the oscillator to a desired standard. Refer to Application Note 52, "Frequency and Time Standards", which is available from HP upon request. HP

specifies maximum aging rates instead of using less conservative "typical" or statistical stability definitions.

Short-term stability is an additive factor in over-all accuracy and refers to changes in average frequency over a time sufficiently short such that the change in frequency due to long-term effects is negligible. Good short-term stability is necessary to permit close agreement from measurement to measurement. Short-term specifications on a counter's internal time base oscillator indicate the average effect of all noise on the counter's gate time accuracy over a certain averaging time. Thus, in the HP 5245L with 2 parts in  $10^{10}$  rms for 1-second averaging, there is no short-term contribution to the gate error for a frequency measurement. This excellent performance is obtained using a crystal oven with proportional electronic control, instead of a less expensive but less stable on-off thermostat control. Averaging time should be expressed over a realistically short-time period; long averaging times can mask large short-term changes.

The attainable accuracy of any electronic counter is limited by the time base oscillator stability, since the time base oscillator supplies the definitive time information for a measurement. The time base must be calibrated periodically, since the drift rate will cause a cumulative deviation in frequency which can result in a measurement error. Figure 8 graphically illustrates the at-

tainable accuracy of the HP 5245L counter assuming an overall time base accuracy of  $1 \times 10^{-5}$  at time of use. Accuracy versus measured frequency is plotted and crossover points indicate areas below which determination of frequency is better performed by period measurement.

The  $\pm 1$  count ambiguity is inherent in measurements made with an electronic counter because the gating is not normally coherent with the input signal. It is possible for the gate to open or close while an input pulse is passing through so that this pulse may or may not be included in the final count. The degree to which the  $\pm 1$  count ambiguity affects measurement accuracy is determined by the factor  $1/\text{displayed count}$ .

Period measurement accuracy is affected by trigger error (a function of the input signal-to-noise ratio and rise time), and by the time base stability, and is computed as follows: percentage error =

$$\pm \left( \frac{1}{f_{in}/f_x} + 0.003 + \text{L.T.} + \text{S.T.} \right) \times$$

100, where  $f_{in}$  = time base frequency counted,  $f_x$  = sine wave input frequency with 40 dB signal-to-noise ratio, 0.003 = trigger error, L.T. = long-term stability of time base oscillator, and S.T. = short-term stability of the time base oscillator. This total error is reduced by the number of periods averaged when multiple period average operation is selected.

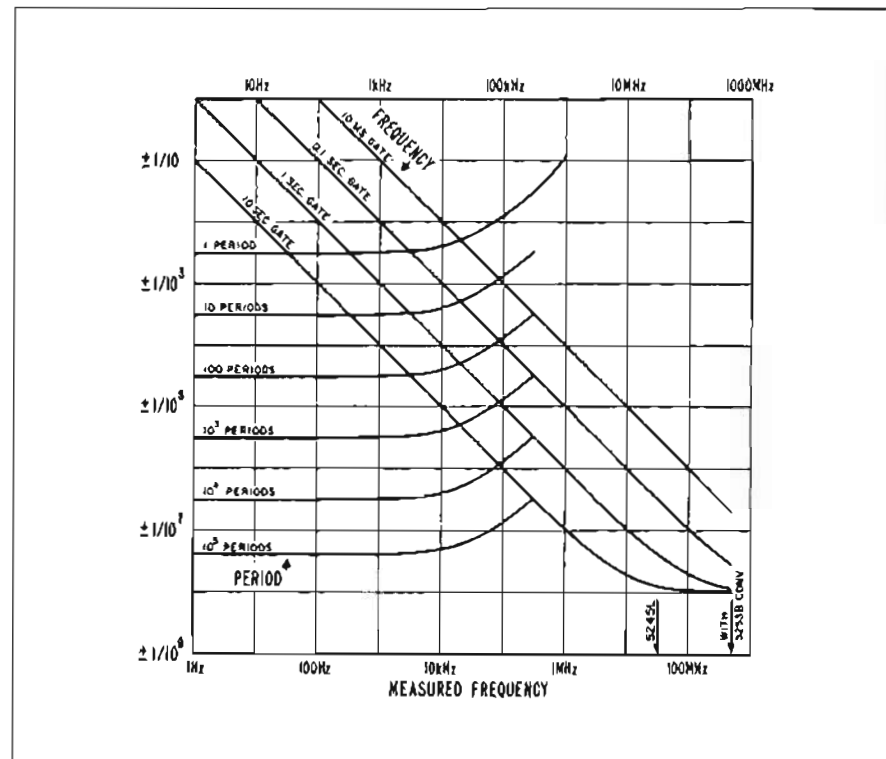

Figure 9. Attainable accuracy of 5245L Counter. Period measurement accuracy based on 10 MHz counted frequency. Time base accuracy was assumed to be 1 part in  $10^8$  overall for this example.



### Solid-state general purpose counters

Instrument	Frequency Range	Measures*	Readout	BCD output	Time Base Aging Rate (gate times)	Model	Price	Page
Most versatile, accurate HP Counter	0 Hz to 50 MHz	F, P, MPA, R, MR†	8 digits in-line	std.	$\pm 3/10^9$ /day (1 $\mu$ sec-10 sec)	5245L	\$2950	500
Economical Counter with Plug-in versatility	0 Hz to 50 MHz	F, R, MR†	6 digits in-line (7 or 8 optional)		$\pm 2/10^7$ /month, $\pm 3/10^9$ /day optional (1 $\mu$ sec-1 sec)	5246L	\$1950	499
Economical 50 MHz Counter	0 Hz to 50 MHz	F, P, MPA, R, MR	7 digits in-line		$\pm 2/10^7$ /month (1 $\mu$ sec-10 sec)	5244L	\$1900	507
Compact, wide range, versatile	0 Hz to 12.5 MHz	F, P, MPA, R, MR, TI	6 digits in-line	opt.	$\pm 2/10^7$ /month (0.01-10 sec)	3735A	\$1650	513
Compact, economical versatile	2 Hz to 5 MHz	F, P, MPA, R, MR, TI	5 digits in-line		$\pm 2/10^6$ /week (0.01-1 sec, 10 sec. opt.)	3734A	\$1075	513
Economical Universal Counters; stable, wide range trigger controls	0 Hz to 2 MHz	F, P, MPA, R, MR, TI	6 digits in-line	std.	$\pm 2/10^7$ /month (10 $\mu$ sec-10 sec)	5233L	\$1600	516
	0 Hz to 300 kHz	F, P, MPA, R, MR, TI	5 digits in-line		$\pm 2/10^6$ /week (10 $\mu$ sec-10 sec)	5223L	\$1275	516
Versatility at moderate cost	2 Hz to 1.2 MHz	F, P, MPA, R, MR	6 digits in-line		$\pm 2/10^7$ /month (0.01-10 sec)	5532A	\$1350	514
			6 digits columnar			5232A	\$1250	
	2 Hz to 300 kHz	F, P, MPA, R, MR	5 digits in-line		$\pm 2/10^6$ /week (0.01-10 sec)	5512A	\$ 975	514
			5 digits columnar			5212A	\$ 875	
Low cost, low frequency Counters	2 Hz to 300 kHz	F, R	4 digits in-line		Power line (0.01-10 sec)	H22-5211B	\$ 775	514
			4 digits columnar			5211B	\$ 675	
					Power line (0.1, 1 sec)	5211A	\$ 575	

### Solid-state special purpose counters

Instrument	Range	Measures*	Readout	BCD output	Time Base	Model	Price	Page	
Reversible Counter, versatile high speed	0 Hz to 2 MHz	Count A, B, A+B, A-B, Af (B), A Quad B	6 digits in-line (7 or 8 optional)	std.	External (internal optional)	5280A (5285A)	\$1450 (\$ 450)	520	
Preset Counter, normalizes count, versatile	2 Hz to 300 kHz	Normalized rate and ratio, ratio, time for N events	5 digits in-line		$\pm 2/10^6$ /week		5214L	\$1300	518
Time Interval Counter	10 nanosec-0.1 sec	TI	7 digits columnar		External		5275A	\$2450	527

**Vacuum tube general purpose counters:** These models have generally been replaced by solid-state models above.

Instrument	Frequency Range	Measures*	Readout	BCD output	Time Base Aging Rate (gate times)	Model	Price	Page
Versatile Plug-in Counters	10 Hz to 10 MHz	F, P, MPA†	8 digits in-line	opt.	$\pm 5/10^8$ /week (1 msec-1 sec)	524C	\$2900	522
			8 digits columnar			524D	\$2650	
10 Hz to 1.2 MHz	F, P, R, TI, PD	5 digits in-line	$\pm 2/10^8$ /week (1 msec-10 sec)		523C	\$1950	524	
		5 digits columnar			523D	\$1700		
		10 Hz to 120 kHz**	F, P, TI		5 digits columnar	$\pm 1/10^5$ /week (1 msec-10 sec)	522B	\$1100
1 Hz to 1.2 MHz	F, elapsed time	5 digits columnar	Power line*** (0.1, 1 sec)		521G	\$ 750	526	
1 Hz to 120 kHz**	F, elapsed time	5 digits in-line 5 digits columnar	0.01% crystal (0.1-10 sec)		521E	\$1125	526	
					521C	\$ 800		
			Power line*** (0.1, 1 sec)		521D	\$ 900	526	
		4 digits in-line 4 digits columnar			521A	\$ 650		

\*F-Frequency, P-Period, MPA-Multiple Period Average, R-Ratio, MR-Multiple Ratio, TI-Time Interval, PD-Phase Delay.

\*\*220 kHz with Option, add \$35.

\*\*\*0.01% crystal, add \$100.

†Accepts plug-ins for wide variety of other measurements

# ELECTRONIC COUNTER

## Economical 50 MHz plug-in counter Model 5246L



# FREQUENCY

The 5246L offers the circuit advantages, basic 0 to 50 MHz range and plug-in accessory feature of the HP 5245L (p. 500). Plug-ins purchased for the 5245L can be used with the 5246L (see p. 502 to 506 for performance with 5246L). The 5246L has display storage, a 6-digit readout (7 and 8-digits optional), and without any plug-ins will measure frequency and frequency ratio. BCD output and a higher stability ( $3 \times 10^{-6}$ /day) crystal time base are optional. A dual field-effect transistor input amplifier offers almost constant 1 megohm/25 pF input impedance, and HP 10000 Series Probes can be used.

Frequency ratio ( $f_1/f_2$ ) is measured by connecting signal  $f_2$  (100 Hz to 1 MHz) in place of the counter's time base (BNC at rear), and connecting  $f_1$  (up to 50 MHz) to the SIGNAL INPUT. Multiple ratios can be measured from 10 to  $10^6$  in decade steps.

### Specifications

#### Frequency measurements

**Range:** 0 to 50 MHz (dc coupled input). 25 Hz to 50 MHz (ac coupled input, maximum sensitivity).

**Gate Time:** 1  $\mu$ sec to 1.0 seconds in decade steps.

**Accuracy:**  $\pm 1$  count  $\pm$  time base accuracy.

**Reads In:** kHz or MHz with positioned decimal point; units annunciator in line with digital display.

**Self Check:** Counts 10 MHz for the gate time chosen by the time base selector switch.

#### Time base

**Frequency (internal):** 1 MHz.

**Stability:** Aging rate: less than  $2 \times 10^{-7}$ /mo.

As a function of line voltage: less than  $\pm 1$  part in  $10^7$  for changes of  $\pm 10\%$ . As a function of ambient temperature: less than  $\pm 2$  parts in  $10^6$  ( $+10^\circ$  to  $+50^\circ\text{C}$ ),  $\pm 20$  parts in  $10^6$  ( $0^\circ\text{C}$  to  $+65^\circ\text{C}$ ).

**External Input:** Sensitivity: 1 volt rms into 500 ohms, sine wave. Range: 100 Hz to 1 MHz, sine wave.

**Output Frequency:** 1 MHz,  $> 3$  V p-p into 1 K $\Omega$ .

#### General

**Registration:** 6 digits in-line with rectangular Nixie tubes and display storage; 999,999 max. display.

**Display Storage:** Holds reading between samples; switch overrides storage.

**Sample Rate:** Time following a gate closing during which the gate may not be reopened is continuously variable from less than 0.2 sec to 5 seconds in frequency mode, independent of gate time; display can be held indefinitely.

**Operating Temperature Range:**  $0^\circ\text{C}$  to  $+65^\circ\text{C}$ .

#### Signal Input

**Maximum Sensitivity:** 100 mV rms; coupling, AC or DC. AC coupling has 0.022  $\mu$ f 600 V DC capacitor ( $-3$  dB at approximately 7 Hz).

**Impedance:** 1 meg shunted by 25 pF.

**Overload:** Diode clamps in series with 100 K and 0.001  $\mu$ f protect input circuit for up to 120 V rms. Input resistance for overload condition (beyond approx. 1 V) is approximately 0.1 megohm.

**Weight:** Net, 28 lbs (12,8 kg) with blank plug-in; shipping, 36 lbs (16,4 kg).

**Power Supply:** 115 or 230 volts  $\pm 10\%$ , 50 to 60 Hz; 95 watts (50 to 1000 Hz operation, inquire).

**Accessories Furnished:** HP 10503A Cable, 4 feet long, male BNC connectors. Detachable Power Cord, 7 $\frac{1}{2}$  ft. (2040 mm) long, NEMA plug. Circuit Board Extender.

**Price:** \$1800.

#### Options

01: 7 digit readout, \$100.

02: 8 digit readout, \$200.

03: 1-2-2-4 "1" state positive 4 line BCD output.

"0" State Level:  $-8$  V.

"1" State Level:  $+18$  V.

Impedance: 100 K ohms, each line.

BCD Reference Levels:

Approximately  $+17$  V, 350 $\Omega$  source.

Approximately  $-6.5$  V, 1000 $\Omega$  source.

Print Command:  $+13$  V to 0 V step, dc coupled.

Hold-off Requirement:  $+15$  V min.,  $+25$  V max. from chassis ground (1000 $\Omega$  source).

Cable Connector: Amphenol 57-30500, 1 req'd \$75.

04: Similar to Option 03 except output is 1-2-4-8 "1" state negative 4 line BCD. \$85.

05: Similar to Option 03 except output is 1-2-4-8 "1" state positive 4 line BCD. \$85.

06: High Stability Time Base Oscillator: Specifications under "Stability", Model 5245L specification, page 501, apply. \$300.

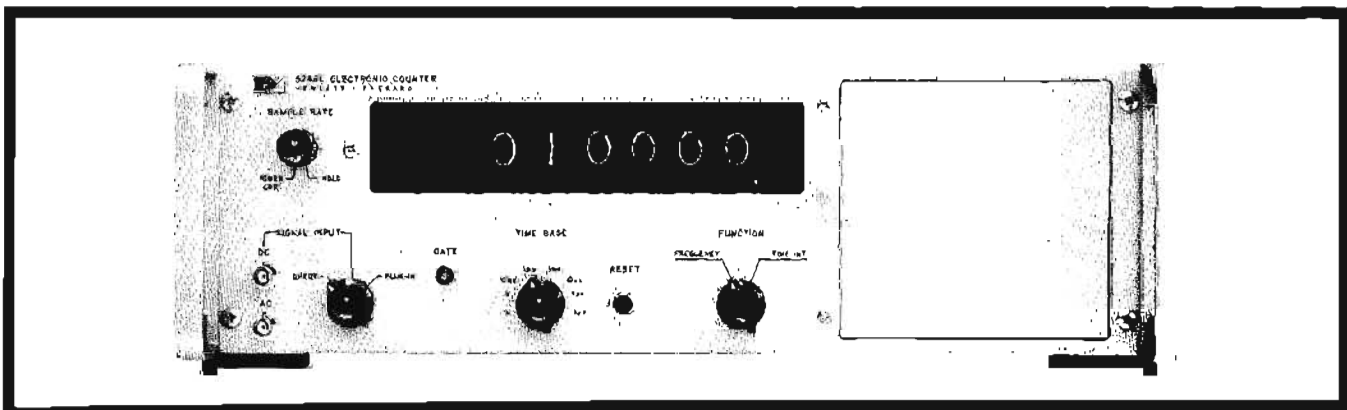



## ELECTRONIC COUNTER

Most accurate, versatile HP plug-in counter

Model 5245L

### Advantages:

- Plug-ins for wide variety of measurements; frequencies to 12.4 GHz
- Excellent long and short-term stability
- High input impedance on all ranges
- Ac or dc coupling (dc usable to 50 MHz)
- Two-mode trigger level control
- Readout storage; BCD output

This solid-state electronic counter measures frequency, period, multiple period average, ratio and multiples of ratio and can be used to scale a signal by decades. Plug-ins, which go directly into the front panel, extend frequency measurements to 12.4 GHz, permit time interval measurements, and will perform a variety of other functions. The basic counter (without plug-ins) offers a counting rate of 50 MHz with 8-digit resolution. For plug-ins, see p. 502-506.

Excellent stability is attained with a proportionally controlled oven for the quartz crystal. Careful design consideration of the effects of temperature and line voltage contributes toward greater realizable measurement accuracy. The time base aging rate of better than 3 parts in  $10^6$ /day makes it useful as a frequency standard. Short-term stability exceeds  $2 \times 10^{-10}$  (1 sec. averaging time).

A dual FET input amplifier provides 1 meg/25 pF input impedance, independent of attenuator setting and frequency up to 50 MHz. Low VSWR is therefore attainable when properly terminated. High impedance probes (e.g., HP 10000 Series) may be used in the same manner as with high frequency oscilloscopes.

### Basic Counter Operation

The 5245L (without plug-ins) measures frequencies and repetition rates of periodic or random pulses from 0 to 50

millions pps. Gate times from 1  $\mu$ sec to 10 seconds are selected with a front panel switch. Multiple period average to  $10^5$  periods is obtained without need for a separate plug-in. This capability, which also applies for ratio measurements since the decade divider assemblies are usable at any frequency, makes possible accurate measurements at low and intermediate frequencies. The increase in accuracy over that possible in single period or ratio is a direct result of division of the trigger error by the averaging factor, as well as the result of increased resolution. Ratios of frequencies that are almost identical can be accurately resolved.

The basic counter will also scale (divide) an input frequency as high as 50 MHz in decade steps by factors up to  $10^9$ . For example a 14 MHz signal can be divided to 0.014 Hz. A rear panel BNC connector and switch provide your choice of nine 5245L output frequencies.

Display storage and a Sample Rate control are provided.

### Input Signal Triggering

Both preset and adjustable modes are provided. In PRESET, trigger level is optimum for signals which are symmetrical about ground; it is useful for most applications, and is automatically selected when plug-ins are used (without moving the TRIGGER control to PRESET). In ADJUSTABLE, the control can be rotated for counting + or - pulses, or for unusual signal conditions.

### Electrical Readout and Remote Control

Four-line BCD code output is provided and is suitable for systems use or for output devices, such as Model 562A or 5050A Digital Recorder, and Model 580A or 581A Digital to Analog Converter. Other codes and remote control of front panel switches are optional.

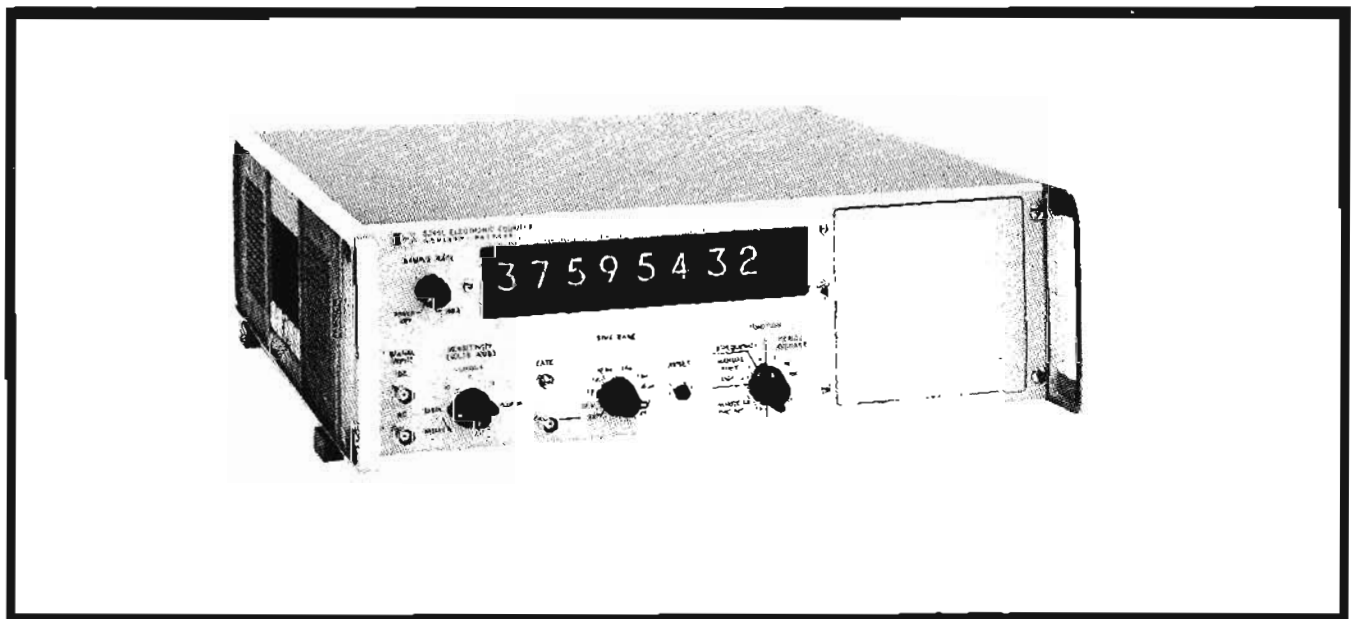



## Specifications

### Frequency measurements

**Range:** 0 to 50 MHz (dc input), typical response  $< \pm 1$  dB, 25 Hz to 50 MHz (ac coupled).

**Gate time:** 1  $\mu$ sec to 10 seconds in decade steps.

**Accuracy:**  $\pm 1$  count  $\pm$  time base accuracy.

**Reads in:** kHz or MHz with positioned decimal point; units annunciator in line with digital display.

**Self check:** counts 10 MHz for the gate time chosen.

### Scaling

**Frequency range:** 0 to 50 MHz.

**Factor:** by decades up to  $10^3$ , switch selected on rear panel. For  $\div 2$ ,  $\div 4$ ,  $\div 8$ , add HP 5252A Prescaler.

**Input:** front panel, signal input.

**Output:** in place of time base output frequencies.

### Period average measurements

**Range:** SINGLE PERIOD ..... 0 to 1 MHz.  
MULTIPLE PERIOD ..... 0 to 300 kHz

**Periods averaged:** 1 period to  $10^5$  periods in decade steps.

**Accuracy:**  $\pm 1$  count  $\pm$  time base accuracy  $\pm$  trigger error.\*

**Frequency counted:**

1 AND 10 PERIOD ..... 1 Hz to 10 MHz in decade steps.

100 PERIOD ..... 10 Hz to 10 MHz.

1,000 PERIOD ..... 100 Hz to 10 MHz.

10,000 PERIOD ..... 1 kHz to 10 MHz.

100,000 PERIOD ..... 10 kHz to 10 MHz.

**Reads in:** Sec, ms,  $\mu$ s, with positioned decimal point; units annunciator in line with digital display.

**Self check:** gate time in 10  $\mu$ s to 1 sec (periods averaged of 100 kHz); counts 100 kHz from the time base.

### Ratio measurements

**Displays:** ( $f_1/f_2$ ) times period multiplier.

**Range:**  $f_1$ : 0 to 50 MHz.  $f_2$ : 0 to 1 MHz in single period. 0 to 300 kHz in multiple period; periods averaged 1 to  $10^5$  in decade steps.

**Sensitivity:** 0.1 V rms, each input (max.).

**Accuracy:**  $\pm 1$  count of  $f_1$   $\pm$  trigger error\* of  $f_2$ .  $f_1$  is applied to the decimal counters (enters Time Base Ext. jack on front panel),  $f_2$  is frequency applied to decade dividers (enters Signal Input jack).

**Reads in:** dimensionless; positioned decimal point for number of periods averaged.

**Self check:** Period Average Self Check applies.

### Time base

**Frequency (Internal):** 1 MHz.

**Stability:** AGING RATE—less than 3 parts in  $10^6$  per 24 hours.† AS A FUNCTION OF TEMPERATURE—less than  $\pm 2$  parts in  $10^6$  per °C from  $-20^\circ$  to  $+55^\circ$ C. AS A FUNCTION OF LINE VOLTAGE—less than  $\pm 5$  parts in  $10^6$  for  $\pm 10\%$  change in line voltage from 115 V or 230 V rms.

**Short term**—less than 2 parts in  $10^6$  rms with measurement averaging time of one second under constant environmental and line voltage conditions.

**Adjustment:** Fine frequency adjustment (range approximately  $4 \times 10^{-3}$ ) and medium frequency adjustment (range approximately  $1 \times 10^{-2}$ ) are available from the front panel through the plug-in hole. Coarse frequency adjustment (range approximately  $1 \times 10^{-3}$ ) is available at the rear of the instrument.

### Output frequencies:

- Rear panel:** 0.1 Hz to 10 MHz in decade steps; switch selected on rear panel; all frequencies available in manual function without interruption at reset except 100 Hz, 10 Hz, 1 Hz, and 0.1 Hz which are interrupted by manual reset; 10 kHz to 10 MHz available continuously in all functions; 1 kHz available continuously for all functions except 100 k period average; stability same as internal time base; 5 volts p-p rectangular wave with 1000 ohm source impedance at 1 MHz and lower; 1 volt rms sine wave with 1000 ohm source impedance only at 10 MHz.
- Front panel:** 0.1 Hz to 1 MHz in decade steps; by Time Base switch; availability defined under Output Frequencies (1) above; stability same as internal time base; 1 V p-p.

**External standard frequency:** 1 MHz, 1 V rms into 1000 ohms required at rear panel BNC connector.

### General

**Registration:** 8 digits in-line with rectangular Nixie® tubes;

\*Trigger error is less than  $\pm 0.3\%$  of one period + periods averaged for signals with 40 dB or better signal-to-noise ratio.

†After 72 hours of continuous operation.

©Burroughs Corporation.

99,999,999 max. display; total width of display including units annunciator and auto-positioned decimal point indication does not exceed 7 inches.

**Display storage:** holds reading between samples; switch overrides storage.

**Sample rate:** time following a gate closing during which the gate may not be reopened is variable from less than 0.2 sec. to 5 seconds in frequency mode, independent of gate time; display can be held indefinitely.

**Operating temperature range:**  $-20^\circ$ C to  $+65^\circ$ C.

**Connectors:** BNC (exc. remote program and BCD out).

### Signal input:

**Maximum sensitivity:** 100 mV rms.

**Attenuation:** step attenuator (SENSITIVITY switch) provides nominal sensitivities of 0.1, 1, and 10 V rms.

**Trigger level adjustment (min.):** front panel control has  $\pm 0.3$  V trigger level range on 0.1 V position,  $\pm 3$  V range on 1 V position,  $\pm 30$  V range on 10 V position. A PRESET position automatically centers trigger level at 0 V.

**Impedance:** 1 meg. parallel with approx. 25 pF, all ranges.

**Coupling:** ac or dc, separate BNC connectors. AC coupling has 600 V dc, 0.22  $\mu$ F capacitor ( $-3$  dB at approx. 7 Hz).

**Overload protection:** diodes protect input circuit for up to 120 V rms on 0.1 V range, 250 V rms on 1 V range, 500 V rms on 10 V range. Input resistance for overload conditions (input amplitude  $>$  ten times SENSITIVITY) is 100 k $\Omega$  on 0.1 V range, and is approximately 1 M $\Omega$  on other ranges.

**Pulse measurements:** front panel TRIGGER LEVEL adjustment allows counting positive or negative pulses.

### Time base external input (front panel):

**Maximum sensitivity:** 100 mV rms.

**Impedance:** 1 megohm, approx. 20 pF, dc coupled.

**Overload:** diodes protect input ckt. up to 120 V rms.

**Digital output:** 4-line BCD 1-2-2-4, "1" state positive. 4-line BCD 1-2-4-8, available as Option 02 ("1" state positive and Option 03 ("1" state negative).

"0" STATE LEVEL:  $-8$  V. "1" STATE LEVEL:  $+18$  V.

**Impedance:** 100 k ohms, each line.

**BCD reference levels:** approximately  $+17$  V, 350- $\Omega$  source; approximately  $-6.5$  V, 1000- $\Omega$  source.

**Print command:**  $+13$  V to 0 V step. DC-coupled.

**Cable connector:** Amphenol 50-pin 57-30500, 1 req'd.

**Hold-off requirement:**  $+15$  V min.,  $+25$  V max. from chassis ground (1000- $\Omega$  source).

**Dimensions:** 5 $\frac{1}{4}$ " high by 16 $\frac{3}{4}$ " wide.

**Weight:** net, 32 lbs (14.4 kg) with blank plug-in panel; shipping, 40 lbs (18.2 kg).

**Power supply:** 115 or 230 volts  $\pm 10\%$ , 50 to 60 Hz; 95 watts. (50 to 1000 Hz operation, price on request.)

**Accessories furnished:** 10503A Cable, 4' long, male BNC connectors. Detachable Power Cord, 7 $\frac{1}{2}$ ' long, NEMA plug. Circuit Board Extender, rack mount conversion parts

**Price:** Model 5245L, \$2,950.

### Optional and special features:

**Option 02.** 4-line BCD 1-2-4-8, "1" state positive (for digits only) in lieu of 1-2-2-4 (identical in other respects to above output data), add \$10.

**Option 03.** 4-line BCD 1-2-4-8, "1" state negative (for digits only) in lieu of 1-2-2-4 (identical in other respects to above output data), add \$10.

**J35-5245L:** similar to 5245L with Option 02 except has 1-2-4-8 output "1" state positive for digits, measurement units, and decimal point, \$2,980. (Note: M47-562A/AR Printer is especially suitable for J35-5245L.)

**J36-5245L:** similar to 5245L with Option 03 except has 1-2-4-8 output "1" state negative for digits, measurement units, and decimal point, \$2,980. (Note: P64-562A/AR Printer is especially suitable for J36-5245L.)

**Electromagnetic compatibility:** Model H60-5245L meets the requirements of military specification MIL-I-6181D, price on request.

**Remote operation:** all functions which may be programmed from the front panel controls (in normal use) may be programmed from a remote location except for the "Sample Rate" (as defined above) and the sensitivity control setting; order H65-5245L, price on request.



## FREQUENCY CONVERTERS

Measure to 12.4 GHz with counter accuracy  
Models 5251A, 5253B, 5254B, 5255A

### Advantages:

- Retains counter accuracy
- Up to 1 Hz resolution in 1 to 4 seconds measurement time
- Easy to operate—has smooth, backlash-free, spurious-free tuning and a level indicator
- Sensitivity is high and relatively constant
- AC coupled input in most models

Frequency converters increase the range of your 5245L or 5246L Counter to 100, 500, 3000, or 12,400 MHz for CW signals. The stability and accuracy of the basic counter are retained in these higher frequency measurements because the converters use a multiple of the 10 MHz signal from the electronic counter crystal oscillator to beat with the signal to be measured. Operation of the equipment is simple and convenient permitting non-technical personnel to make frequency measurements up to 12.4 GHz quickly and accurately.

The basic measurement ranges of the counter are retained with the converter installed. Measurements to 50 MHz are obtained simply by moving the counter Sensitivity control off the "plug-in" position and connecting the input signal directly to the counter input.

The AC coupled inputs of the 5251A, 5253B, and 5254B prevent DC voltages which may be present along with the signal from affecting the measurement sensitivity or damaging the mixer circuits in the converter. The higher frequency AC coupled converters (5253B and 5254B) are unique in that the AC coupling is integrated into the input circuit, so it behaves as a transmission line with good VSWR; this results in relatively constant impedance (and converter sensitivity) over the entire frequency range. Thus, performance of these higher frequency converters is better than if AC coupling were achieved by simply using a series capacitor. VSWR of the 5255A is also excellent.

Models 5253B, 5254B, and 5255A are cavity-tuned. Since constant bandwidth cavities are used, tuning peaks and dial "feel" (tuning peak spread) are the same over the entire dial.

### Operation

The converter subtracts multiples of 10, 50, or 200 MHz (depending upon converter model) from the CW frequency to be measured and provides the difference to be measured by the counter. For example, if a frequency of 279.25 MHz is to be measured with the 5253B, the operator tunes the converter dial upward until the converter Level Indicator shows an acceptable voltage level. This will occur at a dial reading (mixing frequency) of 270 MHz for a 279.25 MHz input. At this dial setting, the converter will subtract 270 MHz from the input signal and pass 9.25 MHz, which the counter will measure and display. The measured frequency is then the sum of the counter reading and the 5253B dial reading.

Readout resolution is 1 Hz with the counter gate time set to 1 second, 0.1 Hz at 10 seconds, 10 Hz at 0.1 second, etc. Counter gate time is automatically multiplied by 4 when the 5255A is used.

### Model 5255A

The 5255A's wide frequency measuring range is unique in the microwave converter field. Previously, only transfer oscillators could make high accuracy 3 to 12.4 GHz measurements. Now, the 5255A and 5245L or 5246L measure frequencies through X-band with greater speed, accuracy, and simplicity at comparable price.

The 5255A can be used as a prescaler to extend the counting and direct readout range of the 5245L or 5246L to 200 MHz. This is because the 5255A has an internal prescaler which divides both the 0 to 200 MHz heterodyne difference frequency and the 5245L or 5246L time base by a factor of four to achieve direct readout in MHz on the 50 MHz 5245L or 5246L Counter. The prescaler input is available at the AUX IN port, and inputs as low as 5 mV between 1 and 200 MHz are prescaled by 4 and displayed directly in MHz on the counter. The 5255A is also useful as a down-converter; the heterodyne difference frequency is available at the AUX OUT port, so that 3 to 12.4 GHz inputs can be beat down to 200 MHz maximum, for oscilloscope observation, etc. Similarly, by adding a detector at AUX OUT, the unit serves as a receiver.

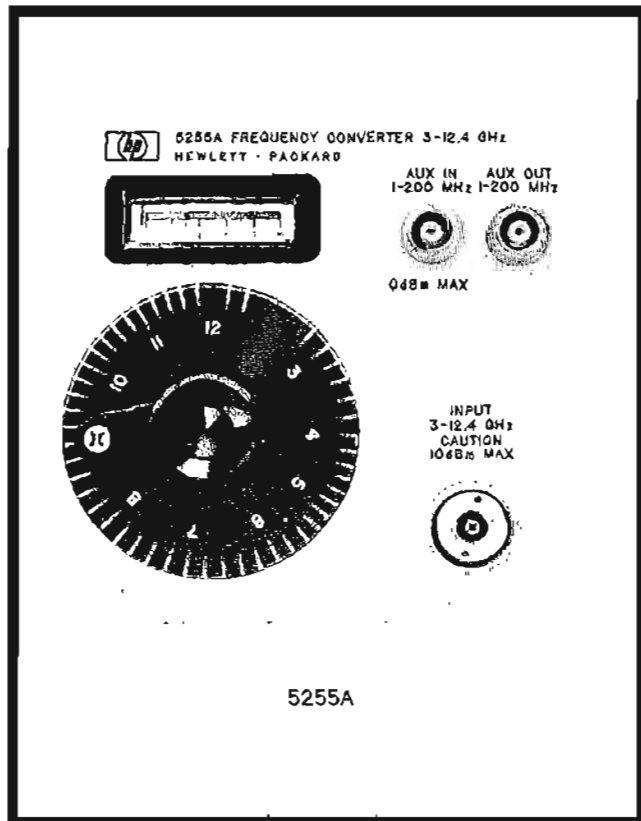

## Specifications

	5255A*	5254B*	5253B**	5251A†
<b>RANGE</b>	3 to 12.4 GHz; as a prescaler, 1 MHz to 200 MHz	0.2 to 3 GHz	50 to 512 MHz	20 to 100 MHz
<b>MIXING FREQUENCIES</b>	2.8 to 12.4 GHz in 200 MHz steps	0.2 to 3 GHz in 50 MHz steps	50 to 500 MHz in 10 MHz steps	20 to 100 MHz in 10 MHz steps
<b>INPUT VOLTAGE RANGE</b> (min. to max., rms)	100 mV (-7 dBm) to 0.7 V (+10 dBm); as a prescaler, 5 mV (-33 dBm) to 0.22 V (0 dBm)	50 mV (-13 dBm) to 1 V (+13 dBm)	50 mV (-13 dBm) to 1 V (+13 dBm)	50 mV (-13 dBm) to 1 V (+13 dBm); typical sensitivity, 20 mV
<b>MAXIMUM INPUT OVERLOAD</b>	0.7 V rms (+10 dBm) (as converter or prescaler)	2.2 V rms (+20 dBm); 125 Vdc	2 V rms (+19 dBm), 250 Vdc	2 V rms (+19 dBm), 100 Vdc
<b>NOMINAL INPUT IMPEDANCE</b>	50 ohms	50 ohms	50 ohms	50 ohms
<b>INPUT COUPLING</b>	dc	ac	ac	ac
<b>ACCURACY</b>	maintains counter accuracy			
<b>REGISTRATION</b>	counter display in MHz is added to converter dial reading			
<b>LEVEL INDICATOR</b>	meter aids frequency selection and indicates usable signal level			
<b>INSTALLATION</b>	into front panel plug-in compartment of some HP Electronic Counters (see footnote)			
<b>INPUT CONNECTOR</b>	Precision Type N female (GPC-7, optional)	Type N female	BNC female	BNC female
<b>WEIGHT</b> net shipping	8½ lbs., 3.8 kg 12 lbs., 5.5 kg	5 lbs., 2.3 kg 9 lbs., 4.1 kg	5 lbs., 2.3 kg 9 lbs., 4.1 kg	2 lbs., 0.9 kg 6 lbs., 2.7 kg
<b>PRICE</b>	\$1,650	\$825	\$500††	\$300††
Specifications apply when used with HP Electronic Counter Model No.: *5245L, 5246L; **5245L, 5246L or 5243L; †5245L, 5246L or 5243L, but 5253B is recommended for 5245L and 5246L since 0 to 512 MHz is thereby covered with the one plug-in. ††Accessory furnished: HP 10503A Cable, 4 ft. (122 cm) long, male BNC connectors.				

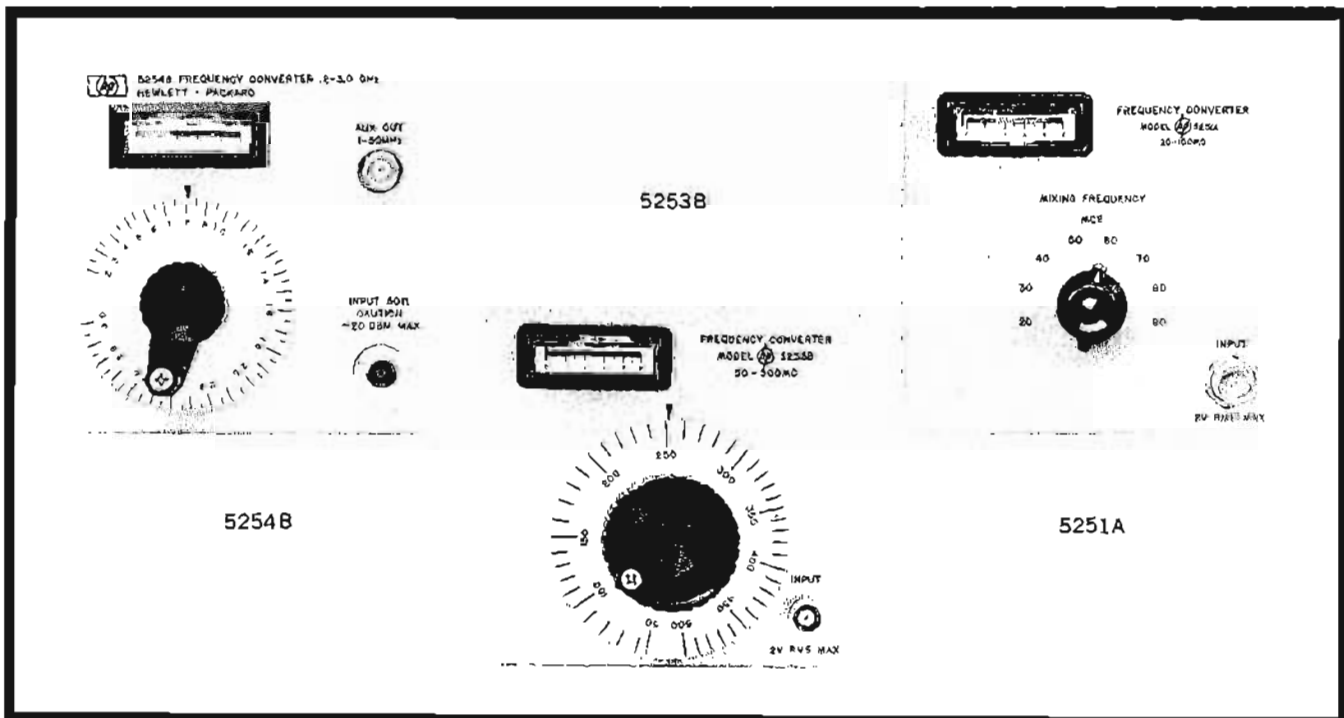



## PRESET UNIT

Normalized readings; div. by N; count N events  
Model 5264A

The HP Model 5264A Preset Unit extends the versatility of the time bases of the HP 5245L and 5246L Electronic Counters, and the counters retain their basic functions and measurement range. Decade dividers in the preset unit control the counter gate; N may be any integer between 1 and 100,000. The 5264A makes possible the following:

**N x frequency measurements (5245L, 5246L):** gate time is controlled by the preset decades (N) and the counter's Time Base switch. The gate is held open for N periods of the time base setting.

This selectable gate time makes possible normalized readings or conversion of frequencies into practical units. The long gate times that are available (5245L— $10^6$  sec; 5246L— $10^5$  sec) permit accurate measurement of low frequencies.

**Ratio, N x ratio measurements (5245L only):** permits ratio measurements with a choice of normalizing factors from 1 to 100,000 in one-digit steps. The counter displays  $Nf_1 \div f_2$ , and  $f_1$  is counted for N periods of  $f_2$ .

**Dividing by N (f/N) (5245L, 5246L):** permits division by N of any input frequency up to 100 kHz. With the 5245L only, a prescaling technique allows frequencies as high as 50 MHz to be divided by a five-digit number, provided that the frequency supplied the preset unit does not exceed 100 kHz.

**N x period measurements (5245L only):** measures the time for N events to occur in increments of 0.1  $\mu$ sec to 10 seconds, depending on the setting of the counter's Time Base switch. Period and multiple period measurements are also easily made. Period average is determined by dividing the time reading by N.

**Preset Counting (5245L, 5246L):** N events are counted. The first event opens the gate; the Nth closes it. This feature is useful in batching, and the gate signal can be used to control external circuitry or relays.

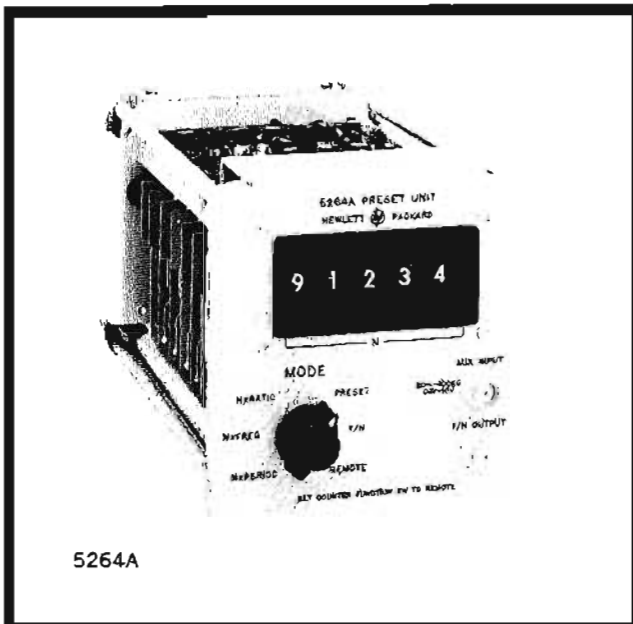

### Specifications, 5264A\*

#### N x frequency (counter signal input)

**Range:** 0 to 50 MHz.

**Gate time:** (set by counter Time Base and "N" switches)

- 10  $\mu$ sec to 1 sec in 10  $\mu$ sec steps
- 100  $\mu$ sec to 10 sec in 100  $\mu$ sec steps
- 1 msec to 100 sec in 1 msec steps
- 10 msec to  $10^3$  sec in 10 msec steps
- 0.1 sec to  $10^4$  sec in 0.1 sec steps
- 1 sec to  $10^5$  sec in 1 sec steps
- $\dagger$ 10 sec to  $10^6$  sec in 10 sec steps

**Accuracy:**  $\pm 1$  count  $\pm$  time base accuracy.

**Maximum sensitivity:** 0.1 V rms.

**Input impedance:** 1 megohm shunted by 25 pF.

#### $\dagger$ N x ratio

##### $f_1$ (counter Ext. Time Base input)

Frequency range: 0 to 50 MHz.

Sensitivity: 0.1 V rms.

Input impedance: 1 megohm shunted by 25 pF.

##### $f_2$ (counter signal input)

Frequency range: 0 Hz to 100 kHz.

Maximum sensitivity: 0.1 volt.

Input impedance: 1 megohm shunted by 25 pF.

**Reads:**  $N \times f_1/f_2$ .

**Accuracy:**  $\pm 1$  count of  $f_1$ .

#### Divide by N (5264A Auxiliary Input, f/N mode)

**Frequency range:** 20 Hz to 100 kHz (sinusoidal).

**Sensitivity:** 0.1 V rms.

**Overload:** signals in excess of 10 V rms may damage the instrument.

**$\dagger$ Prescaling:** in decade steps to  $10^6$  to maximum rate of counter; (scaled output frequency  $\leq$  100 kHz).

**Output:** 0.2 V peak to peak centered at 0 volts, into high-impedance load; rise time  $< 1 \mu$ sec, duration approximately 5  $\mu$ sec.

**Input impedance:** 1 megohm, 50 pF shunt.

#### $\dagger$ N x period (counter signal input)

**Input frequency range:** 0 Hz to 100 kHz.

**Maximum sensitivity:** 0.1 V rms.

**Input impedance:** 1 megohm shunted by 25 pF.

**Time units:** 0.1  $\mu$ sec to 10 sec in decade steps.

**Accuracy:**  $\pm 1$  count  $\pm$  time base accuracy  $\pm$  trigger error.\*\*

#### Preset (5264A Auxiliary input)

**Input frequency range:** 20 Hz to 100 kHz.

**Maximum sensitivity:** 0.1 V rms.

**Overload:** signals in excess of 10 V rms may damage the instrument.

**Input impedance:** 1 megohm, 50 pF shunt.

**Preset range:** 1 to 99,999 in steps of one.

**Weight:** net 3 lbs (1.4 kg); shipping 7 lbs (3.2 kg).

**Accessory furnished:** i0503A cable, 4 ft (1220 mm) long, male BNC connectors.

**Price:** HP 5264A, \$650.

\* When used with HP 5245L or HP 5246L Electronic Counters.

\*\* Trigger error (sine wave)  $< 0.3\%$  of one period  $\div N$  for  $\geq 40$  dB signal-to-noise ratio on input signal; trigger error decreases with increased signal amplitude and slope.

$\dagger$  HP 5245L only.

## VIDEO AMPLIFIER; T. I. UNIT

1 mV sensitivity; 0.1  $\mu$ sec resolution  
Models 5261A, 5262A



## FREQUENCY

### 5261A Video Amplifier

The HP 5261A plug-in increases the sensitivity of the HP 5245L and HP 5246L Electronic Counters to 1 mV rms over the range of 10 Hz to 50 MHz. The output level meter indicates when the signal level to the counter is acceptable for a stable count. The auxiliary 50-ohm output permits monitoring the unknown input signal to the counter with a scope. A 10 megohm 10:1 divider probe is available to facilitate frequency measurements in high-impedance circuits.

### Specifications, 5261A\*

**Bandwidth:** 10 Hz to 50 MHz.

**Input sensitivity:** 1 mV to 300 mV rms.

**Max. Input:** 100 Vdc; 5 V rms (ranges: 1, 3, 10, 30, 100 mV).

**Input impedance:** approximately 1 megohm, 15 pF shunt.

**Output level meter:** shows acceptable signal level.

**Accuracy:** retains accuracy of electronic counter.

**Auxiliary output:** front-panel BNC for oscilloscope monitoring or driving external equipment; 50-ohm source impedance; on amplifier's most sensitive attenuator range, 1 mV rms at input results in at least 100 mV rms at auxiliary output into 50-ohm load; maximum undistorted output is 300 mV rms into a 50-ohm load.

**Accessory furnished:** 10507A Low Microphonic 50-ohm Cable, 4 feet (1220 mm) long, BNC connectors.

**Accessories available:** 10003A 10:1 Probe, 10 pF shunt, 600 V max., \$30; 10100A 50-ohm Feed-Thru Termination, \$15.

**Weight:** net 2 lbs (0.90 kg); shipping 6 lbs (2.7 kg).

**Price:** HP 5261A, \$325.

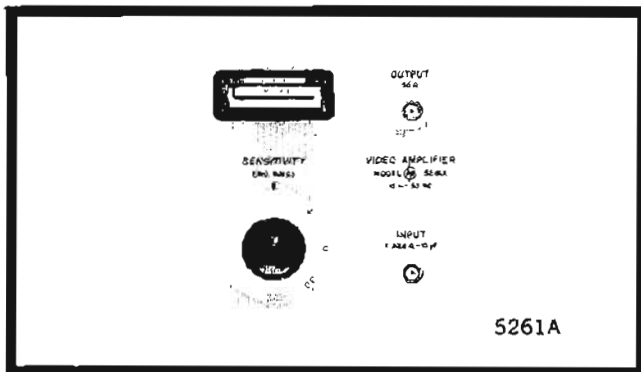

### 5262A Time Interval Unit

The HP 5262A greatly increases the versatility of a 5245L or 5246L by making possible accurate time interval measurements with 0.1  $\mu$ sec resolution. Time is read directly from the counter display with units and decimal point also indicated. Counter time base accuracy is retained, since the counted signal is derived from the time base oscillator. The HP 5262A measures from 1  $\mu$ sec to 10<sup>8</sup> sec with the 5245L or 8-digit 5246L; to 10<sup>6</sup> sec with the standard 5246L. It measures pulse length, pulse spacing and delays, and triggers from separate or common signals. The 5262A may be used as an amplitude discriminator for the 5245L or 5246L, which

permits counting only signals meeting requirements set by trigger level controls.

### Specifications, 5262A\*

**Range:** 1  $\mu$ sec to 10<sup>8</sup> sec (5245L or 8-digit 5246L). 1  $\mu$ sec to 10<sup>6</sup> sec (standard 5246L).

**Standard frequency counted:** 10<sup>7</sup> to 1 Hz in decade steps from 5245L/5246L or external frequency.

**Accuracy (pulse):**  $\pm 1$  period of standard frequency counted  $\pm$  time base accuracy.

**Registration:** on electronic counter.

**Input voltage:** 0.3 volt, p-p, minimum, direct-coupled input.

**Input impedance and overload:** input impedance (constant up to 40 volts times Multiplier setting).

Multiplier	Input Impedance		Max. Input
	Resistance	Capacitance	
X0.1 X0.2 X0.3	10 k 10 k 30 k	80 pF 80 pF 40 pF	50 V rms $\approx 150$ V peak
X1 X3	100 k 300 k	20 pF 20 pF	150 V rms $\approx 250$ V peak
X10 X30 X100	1 meg 3 meg 10 meg	20 pF 20 pF 20 pF	$\approx 250$ V peak

**Start-stop:** separate or common channels.

**Trigger slope:** positive or negative on start and stop channels, independently selected.

**Trigger amplitude:** both channels adjustable,  $-250$  to  $+250$  V.

**Frequency range:** 0 to above 2 MHz when used as input signal discriminator.

**Markers:** (HP 5245L only) separate output voltage steps, 0.5 volt peak-to-peak from source impedance of approximately 7 k, 100 pF; available at rear panel of counter with negative step coincident with trigger points on input waveforms for positive slope and positive step coincident for negative slope.

**Reads in:**  $\mu$ sec, msec, sec with measurements unit indicated and decimal point positioned.

**Accessories furnished:** 10503A Cable Assembly, male BNC to male BNC, 4 feet (1220 mm) long.

**Weight:** net 2.5 lbs (1.1 kg); shipping, 6 lbs (2.7 kg).

**Price:** HP 5262A, \$250.

\*When used with HP 5245L or HP 5246L Electronic Counters.

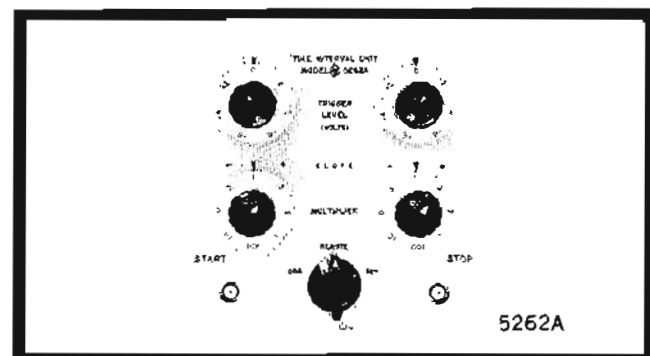

# FREQUENCY



## PRESCALER; DIGITAL VOLTMETER

Increase capability of 5245L and 5246L

Models 5252A, 5258A, 5265A

### 5252A Prescaler

The direct-counting frequency of the HP 5245L and 5246L Electronic Counters is extended to 350 MHz using the Model 5252A Prescaler Plug-in. Prescaling is accomplished with transistor binary dividers which operate over the frequency range dc to 350 MHz. No tuning is required. A trigger level adjustment permits counting when unusual measurement conditions are encountered.

Prescalers divide the input frequency by a factor of 2, 4 or 8, and at the same time adjust the counter's time base to provide a direct reading in frequency.

### 5258A prescaler

5258A installation, use and operation are similar to the 5252A. Tentative specifications: Range, 1 to 200 MHz; Input Scaling Factor,  $\div 4$ ; Input Sensitivity (front panel switch), 1 mV/10 mV/2 V; Input Impedance, 50 ohms. Also useful as video amp., 35 dB max. gain on 1 mV range. Price, \$825

### Specifications, 5252A\*

**Operating frequency range:** dc to 350 MHz.

**Accuracy:** same as the basic counter.

**Input sensitivity:** 100mV rms.

**Maximum input:** 2 volts, +20 dBm, or 100 mW.

**Input impedance:** 50 ohms (nominal).

**Operating temperature range:**  $-20^{\circ}\text{C}$  to  $+55^{\circ}\text{C}$ .

**Scaled output:**  $>100$  mV rms into 50 ohms is available at the AUX A BNC connector of the basic counter.

**Weight:** net 2.2 lbs (1 kg); shipping  $6\frac{3}{4}$  lbs (3,1 kg).

**Price:** HP 5252A, \$685.

### 5265A Digital Voltmeter

The HP 5265A Digital Voltmeter Plug-in quickly converts your 5245L or 5246L Electronic Counter to an accurate dc digital voltmeter. Operation is straightforward—simply set range switch, connect the voltage to be measured and read.

A Local-Remote switch permits remote selection of the DVM mode or the regular electronic counter functions when used with an H65-5245L Counter (remote control option).

### Specifications, 5265A\*\*

**Voltage range:** 6-digit presentation of 10,000, 100,000, and 1000.00 V full scale with 5% overrange capability.

**Registration:** on 5245L or 5246L.

**Reads in:** dc volts with decimal point positioned by range switch; automatic polarity indicator.

**Accuracy ( $0^{\circ}$  to  $+50^{\circ}\text{C}$ ):**  $\pm 0.1\%$  of reading;  $\pm 0.01\%$  of  $f_s < 1/10 f_s$  (within 24 hrs and  $\pm 10^{\circ}\text{C}$  temperature change since last front-panel calibration adjustment and within 6 mos. of calibration of internal zener reference).

**Range selection:** manual.

**Sample rate:** 5 per second. Has storage.

**Input resistance:** 10.2 megohms to dc on all ranges.

**Input filter:**

**AC rejection:** 30 dB at 60 Hz, increasing at 12 dB per octave.

**Response time:** less than 450 msec to a step function to within 0.05% of final value.

**Accessory furnished:** 5060-0630 22-pin extender board.

**Weight:** net  $2\frac{1}{2}$  lbs (1,1 kg); shipping 7 lbs (3,2 kg).

**Price:** HP 5265A, \$575.

\*When used with HP 5246L or 5245L (serial prefixed 402 and above) Electronic Counter.

\*\*When used with HP 5245L or 5246L Electronic Counter.

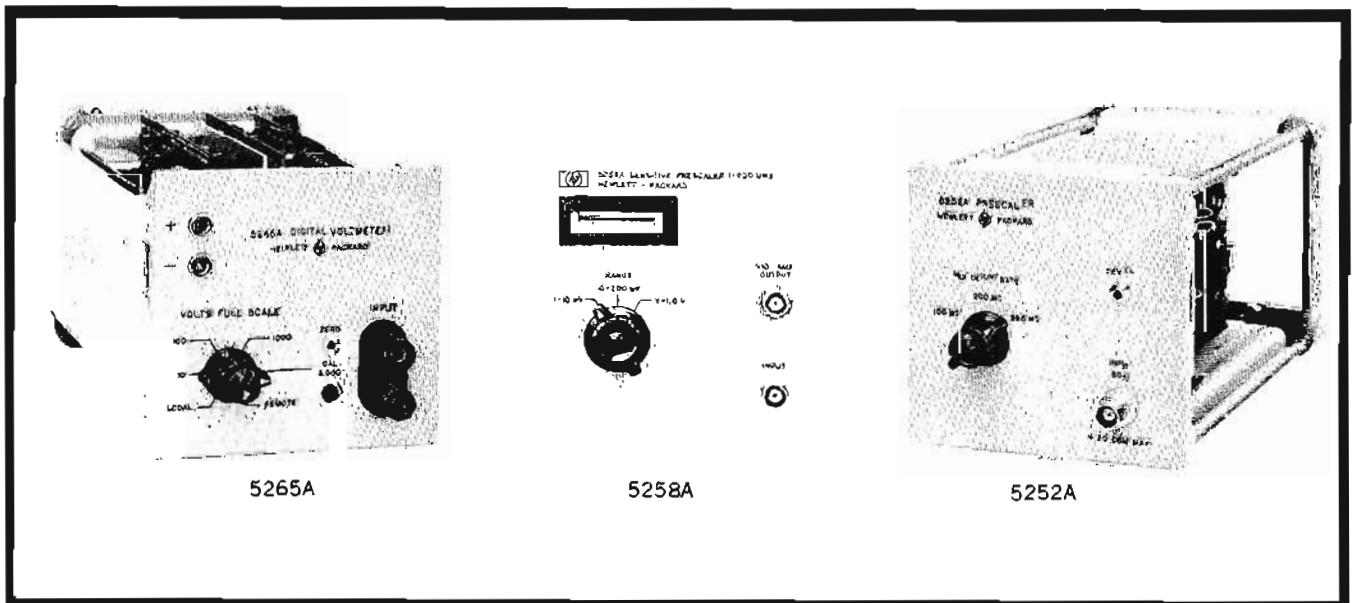

# ELECTRONIC COUNTER

## 50 MHz counting rate with 0.1 V sensitivity

### Model 5244L



# FREQUENCY

The HP 5244L Electronic Counter measures frequency, period, multiple period average, ratio and multiples of ratio with a maximum counting rate of 50 MHz. Rear connectors provide digital output in BCD form. Maximum sensitivity is 0.1 volt rms. The counter time base is a quartz crystal oscillator with an aging rate of less than 2 parts in  $10^7$  per month. Display storage provides a continuous display of the most recent measurement. With the function switch in "Frequency," the "Sample Rate" control adjusts the time between gates from less than 0.2 second to at least 5 seconds.

### Specifications

#### Frequency measurements

**Range:** 0 to 50 MHz, dc input; 50 Hz to 50 MHz, ac input.

**Gate time:** 1  $\mu$ sec to 10 seconds in decade steps.

**Accuracy:**  $\pm 1$  count;  $\pm$  time base accuracy.

**Reads in:** kHz or MHz with positioned decimal point; units annunciator in-line with digital display.

**Self check:** counts 1 MHz for the gate time selected by time base switch.

#### Period average measurements

**Range:** single period, 0 to 1 MHz; multiple period, 0 to 300 kHz.

**Periods averaged:** 1 period to  $10^5$  periods in decade steps.

**Accuracy:**  $\pm 1$  count  $\pm$  time base accuracy  $\pm$  trigger error.\*

**Frequency counted:** single period,  $10^6$  to 1 Hz in decade steps; multiple period,  $10^6$ ,  $10^5$  or  $10^4$  Hz.

**Reads in:** sec, msec,  $\mu$ sec with positioned decimal point; units annunciator in-line with digital display.

**Self check:** gate time is 10  $\mu$ sec to 1 sec; counts 100 kHz.

#### Ratio measurements

**Displays:**  $f_1/f_2$  times period multiplier.

**Range:**  $f_1$ : 50 Hz to maximum rate of counter,  $f_2$ : 0 to 1 MHz in single period; 0 to 300 kHz in multiple period; periods averaged 1 to  $10^5$  in decade steps.

**Sensitivity:**  $f_1$ : 1 V rms from 100 Hz to maximum rate of counter, 2 V rms from 50 to 100 Hz; 2500-ohm input impedance;  $f_2$ : 0.1 V rms, 100 k $\Omega$ /V input impedance.

**Accuracy:**  $\pm 1$  count of  $f_1 \pm$  trigger error\* of  $f_2$ , where  $f_1$  is frequency applied to counting binaries (at Time Base Ext. jack) and  $f_2$  is applied to decade dividers (at signal input jack).

**Reads in:** dimensionless units with positioned decimal.

**Self check:** gate time is 10  $\mu$ sec to 1 sec; counts 100 kHz.

#### Time base

**Frequency:** 1 MHz.

**Stability:\*\*** aging rate: less than  $\pm 2$  parts in  $10^7$  per month; as a function of temperature: less than  $\pm 2$  parts in  $10^6$  for a change from  $+10^\circ$  to  $+30^\circ$ C,  $\pm 20$  parts in  $10^6$  for a change from  $0^\circ$  to  $+65^\circ$ C; as a function of line voltage: less than  $\pm 1$  part in  $10^7$  for  $\pm 10\%$  line voltage change.

**Output frequencies:** 0.1 Hz to 1 MHz in decade steps selected by Time Base switch.

#### General

**Registration:** 7 digits in-line with rectangular Nixie® tubes and display storage.

**Sample rate:** time following a gate closing during which the gate may not be reopened is continuously variable in the frequency function from less than 0.1 second to 5 seconds, independent of gate time; display can be held indefinitely.

#### Input

**Maximum sensitivity:** 100 mV rms.

**Coupling:** ac or dc.

**Attenuation:** step attenuator provides ranges of 0.1, 1 and 10 volts.

**Impedance:** 100 k $\Omega$ /V (10 k $\Omega$  at 100 mV), approximately 40 pF on 0.1 V range, 15 pF on 1 and 10 V ranges.

**Overload:** diodes protect input circuit up to 50 V rms on 0.1-volt range, 150 V rms on 1-volt range, 500 V rms on 10-volt range; 600 V dc tolerable.

**Operating temperature range:**  $-0^\circ$ C to  $+65^\circ$ C.

**Connectors:** BNC type except for BCD output.

**Output:** 4-line 1-2-2-4 BCD with "1" state positive; 1-2-4-8 optional; "0" state:  $-8$  volts; "1" state:  $+18$  volts; impedance: 100 k $\Omega$  ohms each line; reference levels:  $+17$  volts (350-ohm source),  $-6.5$  volts (1000-ohm source); print command:  $+13$  volts to 0 volt step, dc coupled.

**Hold-off requirement:**  $+15$  volts minimum,  $+25$  volts maximum from chassis ground, 1000-ohm source.

**Dimensions:** 16 $\frac{3}{4}$ " wide, 5 $\frac{1}{2}$ " high, 16 $\frac{3}{8}$ " deep (425 x 140 x 416 mm).

**Weight:** net 23 lbs (10.4 kg); shipping 35 lbs (16 kg).

**Power:** 115 or 230 volts  $\pm 10\%$ , 50 to 60 Hz, approximately 80 watts (50 to 1000 Hz operation, price on request).

**Accessories furnished:** 10503A cable assembly, 4 ft (1220 mm), male BNC connectors; detachable power cord 7 $\frac{1}{2}$  ft (2270 mm) with NEMA plug; printed circuit board extender.

**Price:** HP 5244L, \$1900.

#### Options:

01. 8-digit registration, add \$110.
02. 1-2-4-8 BCD ("1" state positive) output (7-digit), add \$10.
03. 1-2-4-8 BCD ("1" state negative) output (7-digit), add \$10.
04. 8-digit registration and 1-2-4-8 BCD ("1" state positive) output, add \$120.
05. 8-digit registration and 1-2-4-8 BCD ("1" state negative) output, add \$120.

**RFI:** The counter, modified to meet electromagnetic compatibility specification MIL-I-6181D, may be obtained by specifying H60-5244L. Add \$350.

\* Trigger error for sine wave input is  $\frac{<0.3\% \text{ of one period}}{\text{periods averaged}}$  for signals with 10 dB or more signal-to-noise-ratio.

\*\* The crystal time base (better than  $\pm 3$  parts in  $10^6$  per 24 hours and better than 2 parts in  $10^{10}$  rms with 1 second averaging) which is used in the 5244L is available on special order. Specify H15-5244L (add \$325).

© Burroughs Corporation

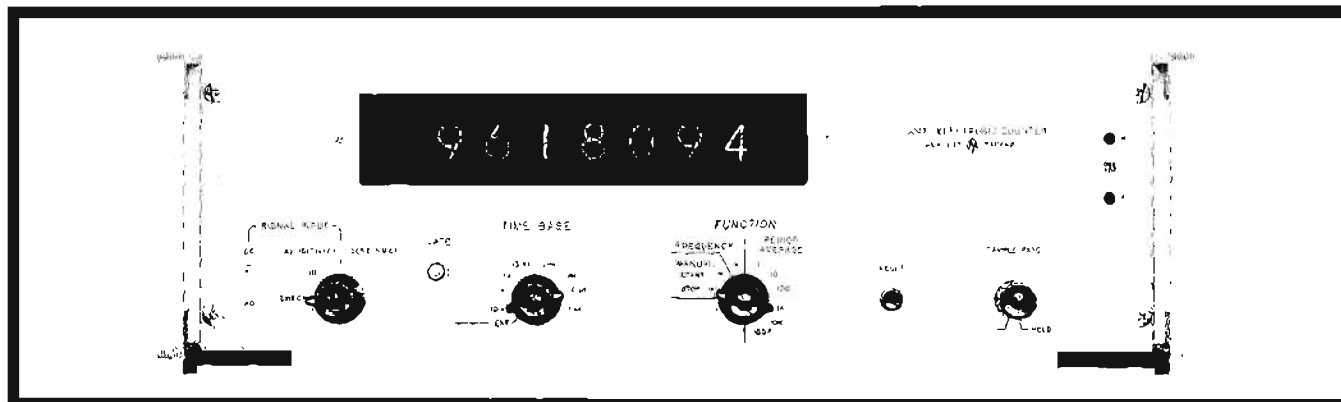





## COMPLEMENTARY EQUIPMENT

Increases versatility of basic instruments

The versatility of Hewlett-Packard counters is greatly enhanced by complementary Hewlett-Packard equipment.

The HP 2590B Microwave Frequency Converter extends the frequency measuring capability of a 5245L (or 5246L) 50 MHz Counter, 5253B 500 MHz Frequency Converter Plug-In combination to 15 GHz. The HP 5260A Automatic Frequency Divider with a suitable Counter makes possible automatic frequency measurements up to 12.4 GHz.

The HP 2539A Digital Comparator and HP 2515A Digital Scanner increase the number of systems applications by providing data handling for making Go/No-Go decisions on counter measurements, and by scanning the BCD outputs of up to six counters.

Various solid state output couplers increase the forms in which the BCD output of counters may be recorded and stored for additional data handling or processing by digital machines.

HP 562A and HP 5050A are solid state digital recorders that provide permanent printed records of counter measurements in digital form. X-Y and strip chart recorders, in conjunction with HP 580A/581A Digital-to-Analog Converters, provide the user with a selection of equipment for analog recording of digital data.

The HP 2212A voltage-to-frequency converter transforms analog information (i.e., voltages) into signals suitable for feeding directly into electronic counters.

Figure 1 demonstrates the capability of the HP-2539A Digital Comparator to compare readings made with the

HP 5246L Counter with a predetermined level (or predetermined upper and lower levels). The result of the comparison is available and may be printed by the HP 562A Digital Printer or fed back to the system being monitored by the counter, thus completing a feedback control system. Front-panel indication of the comparison is also available. The data from the counter used by the digital comparator in the actual comparison is available from the comparator in BCD form. It may be printed with the Go/No-Go indication by the 562A or converted to analog form by the HP 580A, 581A Digital-to-Analog Converters and plotted on a HP680A Strip-Chart Recorder, providing a permanent, visual record of the comparison.

The system in Figure 2 demonstrates the use of the HP 2515A Digital Scanner to scan up to six 5245L 50 MHz Counters with 5253B 500 MHz Frequency Converter Plug-ins, using the HP 2590B Microwave Frequency Converter or HP 5260A Automatic Frequency Divider to measure microwave frequencies. Frequency measurements made by the counters are sequentially or randomly (depending on the mode of operation) scanned by the HP 2515A, and the data, in BCD form, is made directly available to one of four different types of output equipment. The scanner couples directly to the HP 562A, AR Digital Recorders and modified versions of the HP 2545 Tape Punch Coupler, HP 2546 Magnetic Tape Recorder Coupler and HP 2526 Card Punch Coupler. Both the magnetic tape records and the punched cards are IBM-compatible.

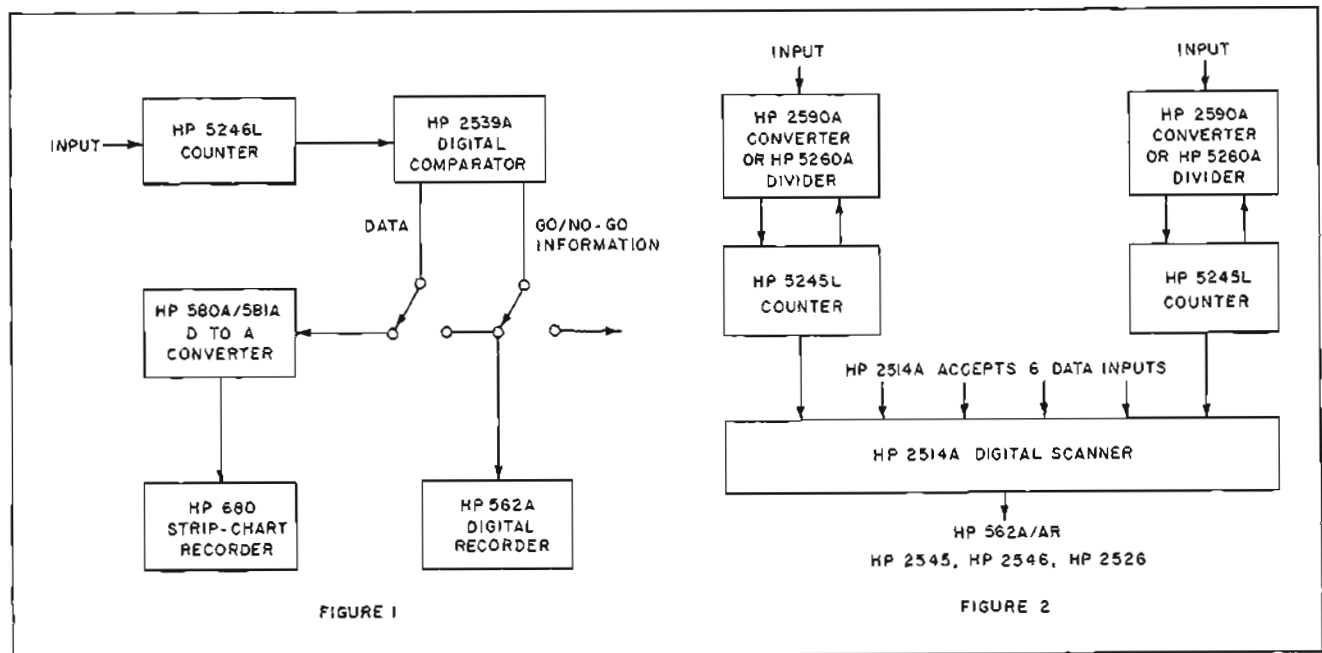

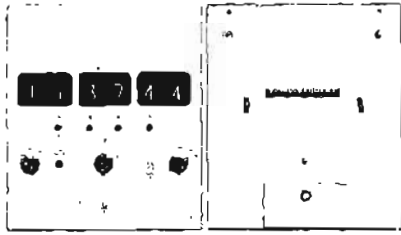

The HP 562A Digital Recorder (shown with HP H03-571B Digital Clock) is the most flexible of a line of recorders featuring parallel entry that provides a permanent printed record of counter measurements. Low inertia moving parts allow printing rates as high as 5 lines/sec. A data storage feature allows transference of data in 2 msec. \$1600 approximately; page 96. The HP 5050A Digital Recorder will print 18 columns at rates up to 20 lines/second, and allows mixed-code operation. Few moving parts, page 95.

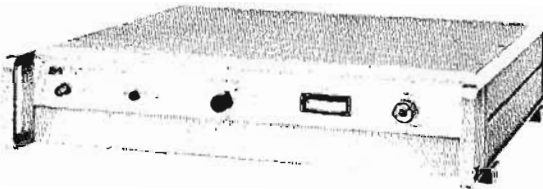

The HP 5260A Automatic Frequency Divider zero beats with input frequencies between 0.3 and 12.4 GHz automatically and without offset, and then provides an output frequency exactly equal to 1/100 or 1/1000 of the input frequency. Thus no tuning or harmonic computation are required, and the input frequency is displayed immediately and directly on an electronic counter. \$3250; page 512.

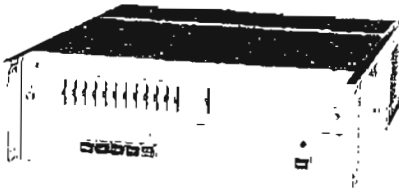

The HP 2515A Digital Scanner transmits digital data from up to six counters to one digital recording instrument. The scanner is compatible with the BCD outputs from all HP solid-state counters, data acquisition systems. The 2515A can operate in either sequential or random scanning modes with continuous scan, single scan or manual steps. \$4200 (3 sources, 12 digits per source); page 80.



The HP 580A, 581A Digital-to-Analog Converters accept 4 line BCD output from all HP solid-state counters. The analog output is available for galvanometer or potentiometer recorders. \$525; page 98.



The HP 2590B Microwave Frequency Converter is an all solid-state instrument with its chassis cast in one piece to completely eliminate troublesome R.F.I. The 2590B measures frequency to 15 GHz by phase-locking an internal transfer oscillator to the signal source. Measurement accuracy is equal to that of the counter time base. A search oscillator is provided to simplify phase locking. \$1900; page 510 (see also HP 540B, \$1100; page 511).

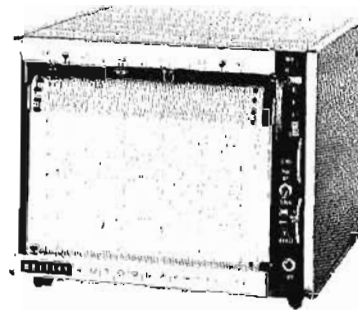

The HP 680A strip chart recorder is a solid-state device with eight chart speeds, continuous zero set and a zener reference. The recorder may be used with a digital-to-analog converter to obtain permanent, visual records of counter measurements versus time. \$750; page 111.



The HP 2539A Digital Comparator compares BCD information against single or dual preset limits providing Go/No-Go lamp indications and electrical output. Comparisons take less than 2 msec. The 2539A provides all possible comparison conditions—combinations of relative sign and magnitude—encountered in measurement situations with counters. \$1850 for 4 digit comparison; page 80.

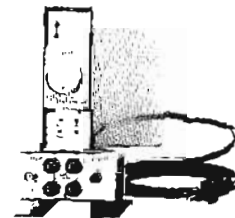

The HP 2212A Voltage-to-Frequency Converter transforms a dc input voltage to a proportional pulse rate output. The counter reads the average value of the signal over the sample period, thereby minimizing effects of noise and ripple. May be used to integrate analog signals over extended periods. \$995; page 235.



## FREQUENCY CONVERTER

Measure frequency to 15 GHz at counter accuracy  
Model 2590B

Model 2590B, in a single compact all-solid-state instrument, performs the functions of a transfer oscillator and a transfer oscillator synchronizer. (HP 540B, p. 511, is a transfer oscillator only).

By phase-locking an internal transfer oscillator to the signal frequency, Model 2590B makes CW frequency measurements inherently equal to the accuracy of the external time base used, even on rapidly drifting signals. With the HP 5253B and 5245L or 5246L complete coverage is provided from dc to 15 GHz with attainable accuracy as high as 5 parts in  $10^{10}$ . Permanently phase-locked, the signal frequency's drift may be tracked continuously over long periods.

The 2590B automatic phase-lock is augmented by an automatic search oscillator, to simplify synchronization at system set-up. An automatic gain control eliminates input level adjustments. The instrument incorporates a precision FM discriminator and an envelope detector, for observation and accurate measurement of FM deviation, deviation rate and signal amplitude modulation.

FM and other short-term frequency disturbances can be observed on an oscilloscope while phase-locked to the signal. For signals with carrier frequency sufficiently stable not to require phase-locking, accurate measurements of FM deviation and deviation rate may be made with the precision built-in discriminator. A separate output from the envelope detector provides for oscilloscope observation and measurement of signal AM, in either FM or phase-locked operating modes.

The carrier frequency of pulsed signals can be determined to well within  $\pm 4$  parts in  $10^6$  using the 2590B with an auxiliary oscilloscope. FM on the pulse also can be observed.

The 2590B is available as an individual instrument to be coupled by the user with a counter, or as part of a complete frequency measuring and recording system.

### Specifications

**Frequency range:** 0.5 to 15 GHz

**Signal input:** minimum level, typically  $-20$  to  $-30$  dBm from 0.5 to 10 GHz increasing  $-7$  dBm at 15 GHz, maximum level,  $+20$  dBm (100 mW); Type N connector.

**Lock-on range:** approx.  $\pm 0.25\%$  of signal frequency in normal APC mode; track mode increases lock-on range to  $\pm 0.35\%$  (approx.) at lower end of transfer oscillator range, decreasing to 0.1% at upper end.

**Accuracy:**  $\pm$  stability  $\pm$  resolution of measurement of transfer oscillator fundamental; stability, same as 10 MHz reference supplied; resolution,  $\pm 1$  count at transfer oscillator frequency, equivalent to 4.2 to 2.5 parts in  $10^6$  with 1 sec counter gate or 4.2 to 2.5 parts in  $10^{10}$  with 10 sec gate.

**External reference:** 10 MHz, 0.1 V min. into 90 ohms; BNC connector.

**FM measurements:** discriminator characteristics when in FM mode: linearity (max. deviation from straight line through origin), better than  $\pm 1\%$  over bandwidth of  $\pm 500$  kHz, better than  $\pm 5\%$  over bandwidth of  $\pm 2$  MHz; video frequency response; 30 Hz to 1 MHz (3 dB points); center frequency, 30 MHz (nominal); sensitivity, 5 V/MHz ( $\pm 10\%$ ); output impedance, 1.2 k ohm; front-panel BNC connector.

**AM measurement:** sensitivity, 100 mV rms (nominal) for 100% modulation at 1 kHz; frequency response, 30 Hz to 1 MHz, load impedance,  $10^6$  ohms shunted by 12 pF max.; front-panel BNC connector.

**APC monitor:** FM on signal may be monitored when in APC operating mode; sensitivity,  $\pm 3$  V minimum for frequency deviation of  $\pm 0.25\%$ ; deviation limits, APC mode can follow frequency deviations up to 0.25% of signal frequency at rates up to 100 Hz; to above 100 Hz, deviation decreases at 6 dB/octave; impedance, measuring device should have min. input impedance of  $10^6$  ohms, shunt capacitance not greater than 20 pF; rear-panel BNC connector.

**Transfer oscillator:** fundamental frequency range, 240 to 390 MHz; drift, less than  $1/10^3$  per hour immediately after turn-on, less than  $1/10^5$  per hour after 2 to 3 hours' operation (oscillator automatically corrected for drift in APC mode); residual FM less than 10 Hz rms; dial,  $2\frac{1}{4}$ " dia. calibrated in 5 MHz increments.

**Power:** 115/230 V  $\pm 10\%$ , 50 to 1000 Hz, approx. 35 W.

**Operating conditions:** ambient temperatures 0 to 55°C, relative humidities to 95% at 40°C.

**Dimensions:** 16 $\frac{3}{4}$ " wide, 5 $\frac{1}{2}$ " high, 16-5/16" deep behind panel (426 x 86 x 414 mm); instrument is fully enclosed for use on bench; may be mounted in 19" rack with side extensions to panel (furnished).

**Weight:** net 23 lbs (10.4 kg); shipping 30 lbs (13.6 kg).

**Price:** Model 2590B, \$1900.

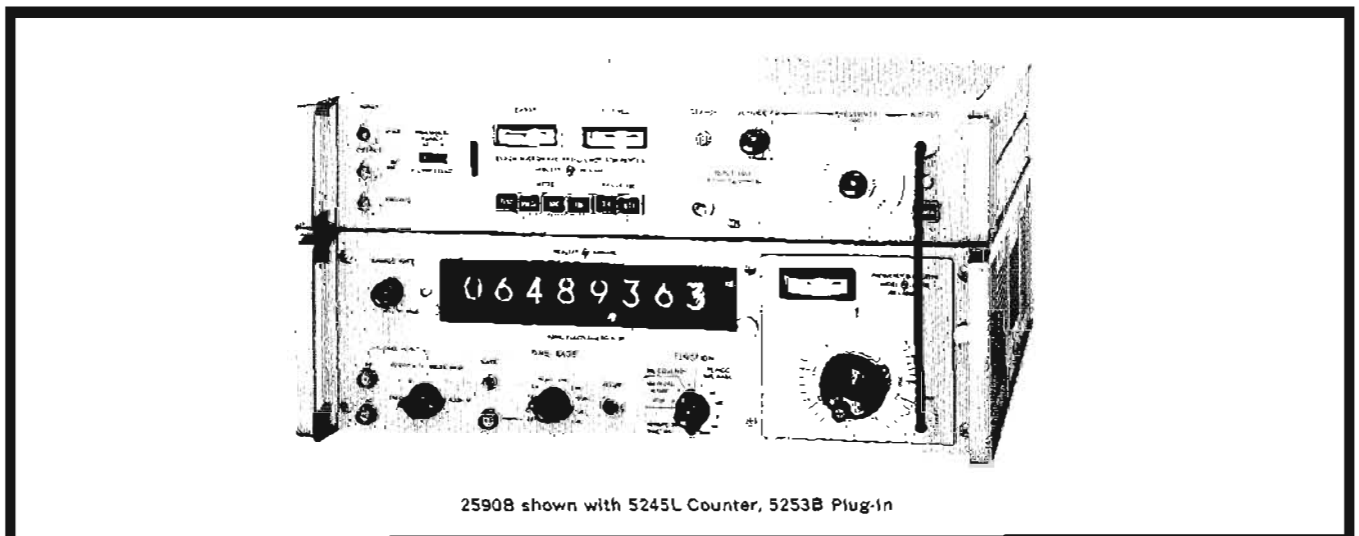

2590B shown with 5245L Counter, 5253B Plug-in

# TRANSFER OSCILLATOR

Measure to 18 GHz with counter accuracy  
Model 540B



## FREQUENCY

### Uses:

- Measure frequency to 12.4 GHz with the 540B Transfer Oscillator plus an electronic counter.
- Add a P932A Harmonic Mixer and measure frequency to 18 GHz.
- Measure frequency of FM signals.
- Determine FM deviation.
- Measure signal frequency of pulsed signals.

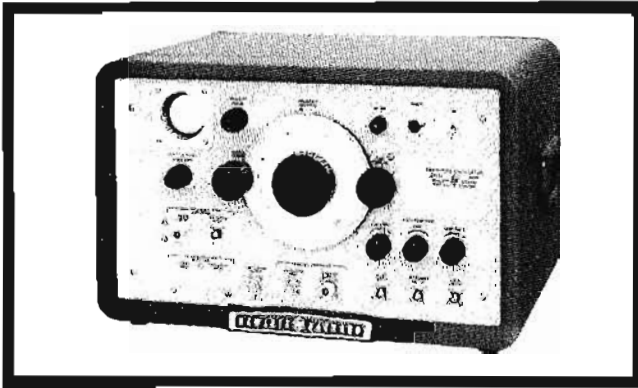

The HP Model 540B Transfer Oscillator provides a straightforward means to extend the frequency range of HP 5245L, HP 5246L, or HP 524 Series Electronic Counters to the microwave region for all types of frequency measurements. It makes possible a completely flexible frequency measuring system for laboratory or industrial use. Using either a 5245L with 5253B Frequency Converter or 5252A Prescaler, or a 524 Electronic Counter with a 525B or 525C Plug-In, the 540 B Transfer Oscillator provides a complete set-up for frequency measurements to at least 12.4 GHz; using the P932A Harmonic Mixer permits measurements as high as 18 GHz.

The P932A mounts directly in the waveguide system and operates with the counter, mixing generated harmonics with the unknown microwave frequency. The mixer's beat frequency output is applied to the 540B. The measuring procedure is the same as the procedure using the 540B's internal mixer.

The system's accuracy approaches that of the electronic counter on clean cw signals. On pulsed signals, accuracy is governed by carrier frequency and pulse length. On noisy or intense AM signals, the transfer oscillator system with the 540B often provides the only means of accurate measurement. Overall system accuracy is greater than 10 times that of the best microwave wavemeters.

A direct-coupled reactance control circuit in the 540B allows the oscillator to be locked at a sub-multiple of the measured frequency when it is desirable to measure automatically or record drift characteristics of microwave signal sources.

### Specifications

**Frequency range:** 10 MHz to 12.4 GHz.

**Input signal:** cw, FM, AM or pulse.

**Input signal level:** varies with frequency and individual crystals. (See chart, upper right.)

**Accuracy:** cw; approximately 1 part in  $10^7$  or better.

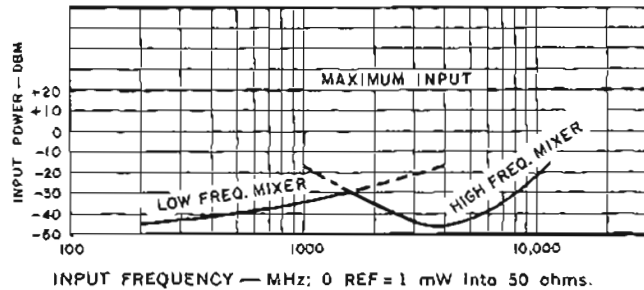

### Oscillator

**Fundamental frequency range:** 100 MHz to 220 MHz.

**Harmonic frequency range:** above 12.4 GHz.

**Stability:** <0.002% change per minute after 30-minute warm-up.

**Dial:** six-inch diameter, calibrated in 1 MHz increments; accuracy,  $\pm 0.5\%$ .

**Output:** approximately 2 V into 50 ohms.

### Amplifier

**Gain:** adjustable, 40 dB max.

**Bandwidth:** variable; high frequency: 3 dB point adjustable approximately 1 kHz to 2 MHz; low frequency: 3 dB point switched from 100 Hz to below 10 kHz, then continuously adjustable to above 400 kHz.

**Output:** 1 V rms maximum into 1000 ohms.

### Internal oscilloscope

**Frequency range:** 100 Hz to 200 kHz.

**Vertical deflection sensitivity:** 5 mV rms per inch.

**Horizontal sweep:** internal, power supply frequency with phase control, or external (connection at rear) with 1 V per inch, 20 Hz to 5 kHz.

### General

**Size:** cabinet: 20 $\frac{3}{4}$ " wide, 12 $\frac{1}{2}$ " high, 15 $\frac{1}{4}$ " deep (527 x 318 x 387 mm); rack mount: 19" wide, 10 $\frac{1}{2}$ " high, 14 $\frac{1}{4}$ " deep behind panel (483 x 267 x 362 mm).

**Weight:** net 42 lbs (19 kg), shipping 52 lbs (23.5 kg) (cabinet); net 35 lbs (15.9 kg), shipping 48 lbs (21.7 kg) (rack mount).

**Power:** 115 or 230 V  $\pm 10\%$ , 50 to 1000 Hz, approx. 110 W.

**Accessories furnished:** 10503A Cable Assembly, 4' (1219 mm) long, BNC-to-BNC; a 6" jumper cable (BNC-to-BNC) is included for use between jacks on front panel.

**Price:** HP 540B, \$1050 (cabinet); HP 540BR, \$1050 (rack mount).

### Auxiliary equipment

5245L, 5246L 50 MHz Electronic Counters (pages 499 through 501).

5252A Prescaler (page 506).

5253B Frequency Converter (page 503).

524C, D 10 MHz Electronic Counters (pages 522, 523).

525B, C Frequency Converters (pages 522, 523).

130C Oscilloscope (pages 422, 423) or other suitable Oscilloscope.

P932A Mixer, 12.4 to 18 GHz. \$250.



## AUTO FREQUENCY DIVIDER

Extends automatic counting range to 12.4 GHz

Model 5260A

### Advantages

- Automatic measurement, 0.3 GHz to 12.4 GHz
- Direct readout, no calculations or offset
- Maintains counter accuracy
- Essentially constant 100 mV sensitivity

Automatic measurement and direct readout of an unusually wide range of CW microwave frequencies can now be achieved using the HP Model 5260A with a suitable electronic counter. The 5260A divides input signals in the 300 MHz to 12.4 GHz frequency range by 100 or 1000 to provide an output signal in the 1 MHz to 12.4 MHz frequency range. Measurements are rapid and simple, with accuracy the same as for basic counter measurements, the frequency being displayed directly on the electronic counter. There is no ambiguity or offset, and no calculations are needed. Except for selecting the proper division ratio, ALL TUNING IS AUTOMATIC AND NO ADJUSTMENTS BY THE OPERATOR ARE REQUIRED TO OBTAIN THE CORRECT OUTPUT READOUT.

### Suitable Electronic Counters (No plug-ins required)

- HP 5245L (see page 500)
- HP M07-5245L (see Option 02)
- HP 5246L (see page 499)
- HP 5244L (see page 501)
- HP 3735A (see page 513)

### Measuring dc to 12.4 GHz

A system for rapid, automatic, direct readout of frequencies from dc to 12.4 GHz can be assembled by combining an HP 5245L or 5246L Electronic Counter (dc to 50 MHz), 5252A Prescaler Plug-in (dc to 350 MHz), and 5260A Automatic Frequency Divider (300 MHz to 12.4 GHz). It is only necessary to select the frequency range desired and read the electronic counter readout; no tuning or calculations are required. Note, however, that 5252A Prescaler is NOT required for operating the 5245L from the 5260A. The 5252A Prescaler is only necessary for measurements within the frequency range 50 MHz to 300 MHz.

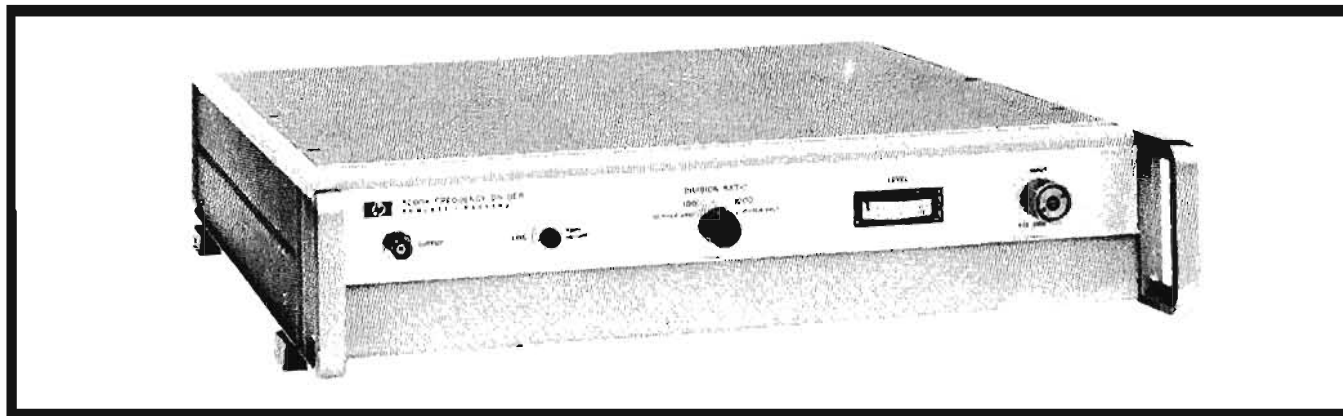

### Specifications

**Range:** 0.3 to 12.4 GHz.

**Accuracy:** retains accuracy of electronic counter.

**Input sensitivity:** 100 mV rms ( $-7$  dBm).

**Input impedance:** 50 ohms nominal.

Input VSWR		
Freq.	Typical	Max.
0.3-8 GHz	1.2:1	1.4:1
8-10 GHz	1.4:1	1.6:1
10-12.4 GHz	1.8:1	2:1

**Maximum input:**  $+10$  dBm.

**Level indicator:** front panel meter indicates approximate input level,  $-10$  dBm to  $+10$  dBm.

**Division ratio:** front panel switch selects  $\times 100$  (for use up to 1.2 GHz) or  $\times 1000$  (from 1 to 12.4 GHz) operation.

**Input connector:** precision Type N female.

**Operation:** completely automatic once the DIVISION RATIO switch is positioned.

**Output frequency:**  $1/100$  or  $1/1000$  of input (1 to 12.4 MHz).

**Output impedance:** designed for 50 ohm (or higher impedance) load.

**Output level:** 0 dBm, nominal.

**Registration:** input frequencies from 0.3 to 12.4 GHz are measured by measuring the 5260A output with an electronic counter such as the HP 5245L, 5246L or 5244L, and suitably positioning the decimal point. Readout is direct with no offset, ambiguity, or arithmetic processing. See also Option 02, below.

**Power supply:** 115 or 230 V  $\pm 10\%$ , 50 to 60 Hz. Other frequencies on special order.

**Weight:** net  $25\frac{1}{2}$  lbs (11.4 kg); shipping 31 lbs (14.1 kg).

**Dimensions:**  $16\frac{3}{4}$ " wide,  $3\frac{15}{32}$ " high,  $16\frac{3}{8}$ " deep (425 x 88 x 416 mm).

**Price:** Model 5260A Automatic Frequency Divider, \$5,250.

#### Options:

- 01 Amphenol APC-7 Input Connector, add \$25
- 02 Provides 5260A with circuitry such that, when used with the HP Model M07-5245L Electronic Counter, the decimal point will be automatically positioned for readout in GHz, and the symbol "GHz" will appear in the counter's readout. Readout is inhibited and displays all zeros unless an adequate input signal is present. Add \$175.

# ELECTRONIC COUNTERS

Compact counters to 12.5 MHz

Models 3734A, 3735A



## FREQUENCY



3734A

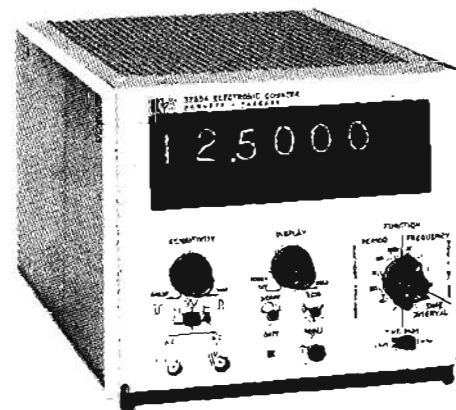

3735A

The Models 3734A and 3735A are compact, multi-function counters. They provide measurement capability for frequency, time interval, period, multiple period average, ratio and multiple ratio, and event totalizing. The 3734A offers an upper count capability of 5 MHz, with 5 digit resolution; the 3735A count rate extends to 12.5 MHz, with 6 digit resolution.

Both units are suited to low level measurement; the 3735A

has an excellent input sensitivity characteristic of 10mV, an input selector for pulses, and ac or dc coupling to 12.5 MHz. The 3734A has a 100mV sensitivity, and is ac-coupled. Each has an in-line digital tube display, and offers display storage. The HP 3735A has an automatic decimal point, and units indicator.

These compact, reliable counters operate stably over a wide temperature range.

### Specifications

Counter	3734A	3735A
<b>Frequency Range</b>	2 Hz to 5 MHz	0 to 12.5 MHz (dc input) 2 Hz to 12.5 MHz (ac input)
<b>Accuracy</b>	±1 count = time base accuracy	
<b>Reads in</b>	kHz with positioned decimal	kHz or MHz with positioned decimal point. Units indicator.
<b>Gate time</b>	1, 0.1, 0.01 sec, 10 sec optional	10, 1, 0.1, 0.01 sec
<b>Input sensitivity</b>	100 mV rms sine wave 1 volt pulse 0.2 μsec width	10 mV rms sine wave 100 mV pulse 50 nsec width
<b>Input impedance</b>	1 MΩ shunted by 15 pF	100 kΩ shunted by 15 pF
<b>Input selector</b>	N/A	optimum response for positive or negative inputs
<b>Sample rate</b>	0.2 to 5 sec	0.04 to 5 sec
<b>Period/multiple period average Range</b>	2 Hz to 100 kHz	1 Hz to 1 MHz
<b>Accuracy</b>	±1 count = time base accuracy = (trigger error ÷ periods averaged)	
<b>Reads in</b>	msec and μsec with positioned decimal point	
<b>Periods averaged</b>	1, 10, 10 <sup>2</sup> , 10 <sup>3</sup> , 10 <sup>4</sup> , 10 <sup>5</sup>	
<b>Ratio/multiple Ratio Reads</b>	f <sub>1</sub> /f <sub>2</sub> x period multiplier	
<b>Range</b>	f <sub>1</sub> : 100 Hz to 2 MHz f <sub>2</sub> : 2 Hz to 300 kHz	f <sub>1</sub> : 100 Hz to 1 MHz f <sub>2</sub> : 1 Hz to 1 MHz

Counter	3734A	3735A
<b>Accuracy</b>	±1 count of f <sub>1</sub> = (trigger error ÷ period multiplier)	
<b>Time interval Range "INT"</b>	10 μsec to 999.99 msec	1 μsec to 999.999 sec
<b>Frequency Counted</b>	INT: 100 kHz EXT: 2 Hz to 5 MHz	INT: 1 MHz or 1 kHz EXT: 100 Hz to 1 MHz
<b>Electrical input</b>	separate start and stop channels on rear panel pulse; amplitude: 12 to 25 volts positive pulse width: 1 μs	
<b>Accuracy</b>	±1 count = time base accuracy = trigger error	
<b>Time base Frequency</b>	100 kHz	1 MHz
<b>Aging rate</b>	< ±2 parts in 10 <sup>6</sup> per week	< ±2 parts in 10 <sup>7</sup> per month
<b>General Registration</b>	5 digits	6 digits
<b>Operating temperature</b>	-10 to +50°C	-20 to +50°C
<b>Power</b>	115/230 V switch, 50 to 1000 Hz 30 watts 50 watts	
<b>Dimensions</b>	7-25/32" wide, 6-3/32" high, 11" deep (90 x 115 x 279 mm)	
<b>Weight</b>	12.5 lb (5.8 kg)	14 lb (6.4 kg)
<b>Price</b>	\$1075	\$1650
<b>Options:</b>	01: 10 second gate, \$40 02: BCD Output +1224, \$30 03: BCD Output +1248, \$85 04: BCD Output -1248, \$85	02: BCD Output \$1224, \$35
Manufactured by Hewlett-Packard Ltd., Scotland		



## ELECTRONIC COUNTERS

Versatile, low cost, 1.2 MHz and 300 kHz counters  
Models 5211A,B, 5212A, 5512A, 5232A, 5532A

### Advantages:

- Reliable, rugged and compact
- High input impedance, high sensitivity
- Low power consumption with solid-state components
- Display storage
- Accurate measurement of frequency, ratio, period, multiple period
- Higher sampling rates; sampling time independent of gate time

These six Hewlett-Packard electronic counters offer the advantages of solid-state construction, broad measurement capabilities, rugged and compact packaging and a wide selection of performance characteristics.

Maximum counting rate ranges from 300 kHz to 1.2 MHz. A variety of visual readouts contain from 4 to 6 digits, with both in-line digital tube and neon columnar displays. Features offered in common by all six counters include modular cabinets only 3½" high, low heat dissipation and power consumption with solid-state components, 0.1 V sensitivity, display storage for non-blinking readout, four-line BCD output for systems and recorders (optional for 5211A), flexible operation and reduced operator errors. When a counter is in the frequency mode, the time between counts is adjustable from less than 0.2 second to more than 5 seconds and is independent of gate time. Because time between counts is not dependent upon gate time, faster sampling rates are often possible.

The instruments are compact and reliable, have low power consumption and can operate with specified accuracy over a wide temperature range. Plug-in module construction increases instrument versatility and simplifies maintenance. Conservative design features such as the use of decade dividers in the gate generating circuits, provide operational stability and eliminate calibration problems. Input sensitivity is 0.1 V rms, input impedance, 1 megohm, 50 pF.

### 5211A,B Counters

Models 5211A and 5211B have a maximum counting rate of 300 kHz and make direct frequency and ratio measurements. They also measure speed in rpm and rps, when used with transducers, and count events occurring within a selected period of time. They offer four-digit resolution and neon columnar display. They are identical except for gate times and recorder

output. The 5211A has gate times of 0.1 and 1 second; the 5211B has a third gate time of 10 seconds.

Both offer manual control of the gate by a front-panel function switch, by external contact closure or by 3 volt peak positive pulses at least 10 μsec wide at half-amplitude points. Time base is derived from the power line, and since power line frequency is usually held to better than 0.1%, the counters have an accuracy fully adequate for most industrial measurements. A special modification of the 5211B, the H22-5211B, offers an in-line readout.

### 5212A, 5512A, 5232A, 5532A Counters

With this group of solid-state instruments, two basic counters give maximum counting rates of 300 kHz and 1.2 MHz, with a choice of column or in-line readout. Each makes direct frequency, period, multiple period average and ratio measurements. Models 5212A and 5512A have a maximum counting rate of 300 kHz, 5-digit resolution and respective displays of neon columns and long-life digital display tubes. Models 5232A and 5532A have maximum counting rates of 1.2 MHz and 6-digit resolution with the same readout choice.

The front panel of each counter has input attenuation control, display control, reset button and function switch. In the rear are the storage-disable switch, external standard input jack (permits use of an external oscillator as the counter time base) and digital recorder output connector. Self-check is provided for both frequency and period measurement modes.

### General specifications

**Operating temperature range:** -20°C to 50°C for 5211A, B; -20°C to +65°C for 5212A and 5512A; 0°C to +65°C for 5232A and 5532A\*.

**Weight:** all models, net less than 15 lbs (6.8 kg), shipping less than 21 lbs (9.5 kg).

**Dimensions:** 16¾" wide, 3½" high, 11¼" deep (425 x 89 x 286 mm); hardware furnished for converting to 19" wide by 3½" high rack mount.

**Power:** 115 or 230 V ±10%, 50 to 60 Hz\*\*, less than 40 W.  
**Accessories furnished:** 10503A Cable, 4 feet long, BNC connectors; detachable power cord; circuit board extender.

\*The 5232A and 5532A will operate from -20°C to +65°C on special order or with an external time base.

\*\*HP 5211A,B require 50 or 60 Hz operation (specify Option 01. for 50 Hz operation); 5212A, 5512A, 5232A and 5532A operate between 50 and 60 Hz line frequency with limit imposed by fan.

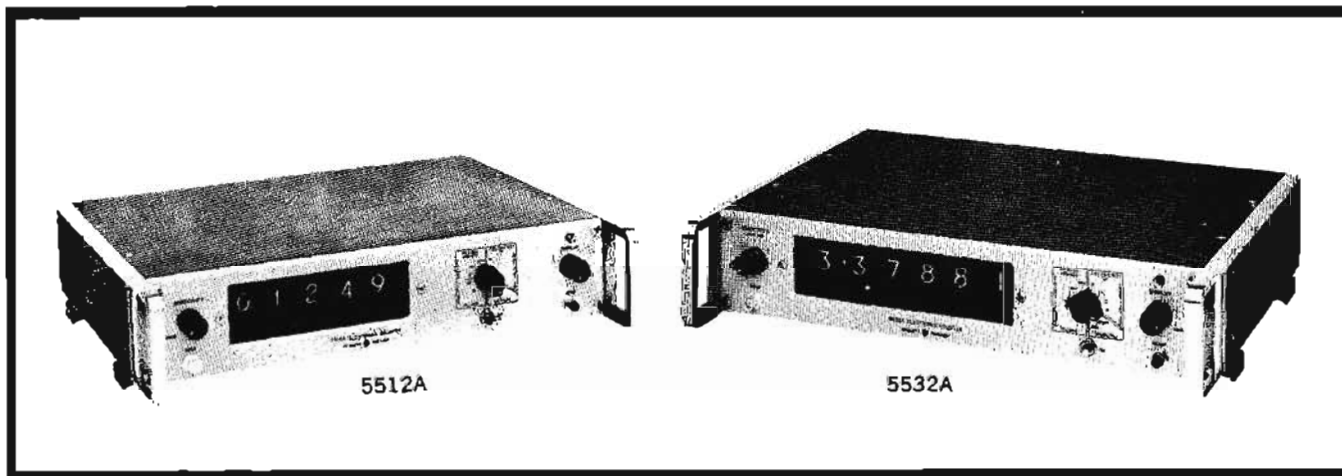



HP Counter		5211A,B	5212A	5512A	5232A	5532A
Max. counting rate		300 kHz	300 kHz	300 kHz	1.2 MHz	1.2 MHz
Registration		4 digits columnar	5 digits columnar	5 digital display indicators	6 digits columnar	6 digital display indicators
Time base		power line; accuracy typically $\pm 0.1\%$ or better	100 kHz crystal oscillator; aging rate, $\approx 2/10^6$ /week		1 MHz crystal oscillator; aging rate, $\approx 2/10^7$ /month	
Input		sensitivity, 0.1 V rms sine wave; input impedance approx. 1 meg/50 pF				
Period and multiple period average measurement	Range	—	2 Hz to 300 kHz		2 Hz to 1.2 MHz	
	Accuracy	—	$\approx$ one count, $\approx$ time base accuracy, $\approx$ trigger error			
	Reads in	—	msec or $\mu$ sec with positioned decimal			
	Periods averaged	—	1, 10, $10^2$ , $10^3$ , $10^4$ , $10^5$			
Frequency measurement	Range	2 Hz to 300 kHz			2 Hz to 1.2 MHz	
	Accuracy	$\approx$ 1 count, $\approx$ time base accuracy				
	Reads in	KHz, Hz with positioned decimal	KHz with positioned decimal			
	Gate time	1, 0.01 sec; 5211B, additional 10 sec	10, 1, 0.1, 0.01 sec			
Ratio measurement	Reads	$f_1/f_2$	$f_1/f_2 \times$ periods averaged			
	Range	$f_1$ : 2 Hz to 300 kHz (0.1 V rms); $f_2$ : 100 Hz to 300 kHz (1 V rms into 1000 ohms)	$f_1$ : 100 Hz to 300 kHz (1 V rms into 1000 ohms); $f_2$ : 2 Hz to 300 kHz		$f_1$ : 100 Hz to 1.2 MHz (1 V rms into 500 ohms above 1 kHz, 2 V rms into 500 ohms 100 Hz to 1 kHz); $f_2$ : 2 Hz to 300 kHz	
	Accuracy	$\approx$ 1 count of $f_1$ , $\approx$ trigger error of $f_2$				
Recorder output (optional at added cost in 5211A; standard in all other models)		4-line BCD (1-2-2-4); 4-line BCD (1-2-4-8) available as Option 02				
	Impedance	100 K each line				
	"0" state level	approximately $\sim$ 28 volts				
	"1" state level	$\sim$ 2 volts				
	Reference levels print command	approximately $\sim$ 2.4 volts, 350-ohm source impedance; and approximately $\sim$ 26.9 volts, 1000-ohm source impedance				
	Hold-off requirements	$+28$ V step, from 2700-ohm source in series with 1000 pF chassis ground to $+12$ volts maximum				
Price		HP 5211A, \$575 HP 5211B, \$675	HP 5212A, \$975	HP 5512A, \$975	HP 5232A, \$1250	HP 5532A, \$1350

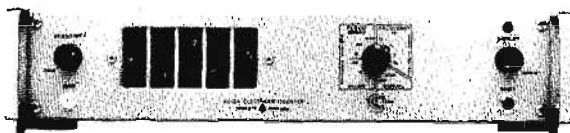
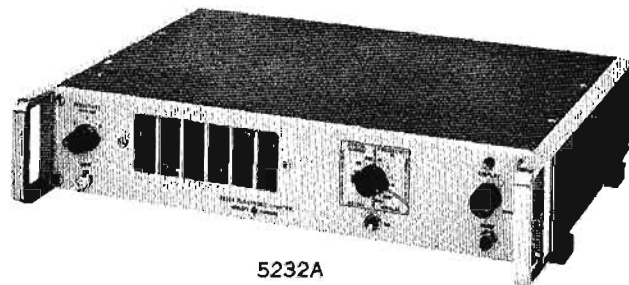



## ELECTRONIC COUNTERS

Versatile universal counters to 2 MHz

Models 5223L, 5233L

### Advantages:

- Superior trigger level controls usable in all functions
- Improved readability with rectangular digital tubes
- Minimum bench or rack space, 3 1/2" panel height
- Reliable, rugged and completely solid state
- Versatile, yet easy to operate
- More accurate low-frequency measurements with multiple period averages
- Low-level measurements without accessories;
  - 0.1 volt sensitivity
- Coupling ac or dc
- Display storage

### Uses:

- Measure frequency
- Count periodic or random pulses
- Measure period, period average, time interval
- Determine ratio and multiples of ratio
- With transducers, measure speed, flow rate, other physical variables
- Scale inputs

Models 5223L and 5233L are universal electronic counters. They measure time interval, frequency, period, multiple period average, ratio and multiple ratio. The 5223L provides a maximum counting rate of more than 300 kHz and 5-digit resolution, and the 5233L provides a maximum counting rate of more than 2 MHz with 6-digit resolution. Both instrument readouts are in-line displays of rectangular digital tubes.

### DC coupling

With the 5223L and 5233L, dc coupling allows accurate trigger point definition with low input amplifier noise and low trigger drift.

With the ac-coupled input, triggering responds to an average dc level. Therefore, the trigger point will change with wave shape and repetition rate. This situation is not of great significance in frequency measurements since

it is only desired to count the number of zero crossings. However, if a pulse of large amplitude and duration is followed by a pulse of small amplitude and duration, the trigger may miss the small pulse, if circuit time constants are such that the average dc level does not have time to recover. This would be a serious limitation in nuclear work, where counted pulses are random in amplitude and width. The variability of trigger point with repetition rate and wave shape (produced with ac coupling) is a serious source of error in time interval measurements — some doubt always exists as to where the actual trigger point is. It may be a point of low slope near the top of a pulse where noise can cause appreciable error.

### Optimum trigger point definition

The 5223L and 5233L each provide two identical input channels for optimum trigger point definition. Separate or the same signals may be used to start and stop the count; the time interval measured may be selected between any desired points on either signal with a choice of ac or dc coupling. Input channel controls allow selection of the slope, amplitude and polarity of the trigger voltage for all other measurement functions, as well as time interval.

Any input amplifier drift or noise will add to the trigger ambiguity. The effect of this internal noise becomes increasingly apparent as the input signal-to-noise ratio increases. Consequently, for precise measurement capabilities, each input channel of the 5223L and 5233L has been designed to minimize amplifier drift and noise. In these instruments the amplifier noise referred to the input is typically less than 100 microvolts.

Particular design care was necessary to insure that these input amplifiers would possess an extremely wide dynamic range. This insures that the input signal peaks can exceed the highest level control adjustment for the next higher attenuator range without changing the dc level. For example, on the X1 attenuator position, peaks considerably beyond 10 volts do not alter the zero crossover point.

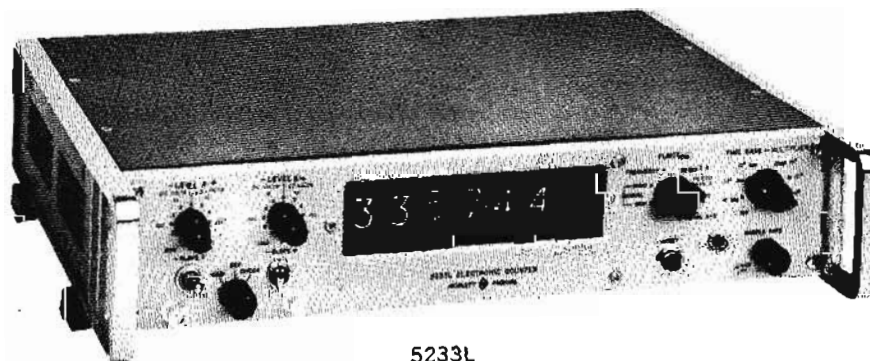

5233L

	5223L Electronic Counter	5233L Electronic Counter
Input channels (A and B)	<p>Range: dc coupled: 0 to more than 300 kHz; ac coupled: 10 Hz to more than 300 kHz.                      Impedance: approx. 1 megohm, 80 pF shunt.                      Sensitivity: 0.1 V rms sine wave; 1 V pulse, 1 μsec min. width.                      Trigger level: -100 to +100 V, adjustable, either positive or negative slope; independent controls on each channel.                      Channel inputs: Common, Separate, Check.                      Marker output: available at rear panel for oscilloscope intensity modulation to mark trigger points on input waveforms; &gt;1 μsec duration and -15 V peak.</p>	<p>Range: dc coupled: 0 to more than 2 MHz; ac coupled: 10 Hz to more than 2 MHz.                      Impedance: approx. 1 megohm, 80 pF shunt.                      Sensitivity: 0.1 V rms sine wave; 1 V pulse, 0.2 μsec min. width.                      Trigger level: -100 to +100 V, adjustable either positive or negative slope; independent controls on each channel.                      Channel inputs: Common, Separate, Check.                      Marker output: available at rear panel for oscilloscope intensity modulation to mark trigger points on input waveforms; 1 μsec duration and -15 V peak.</p>
Time interval	<p>Range: 10 μsec to 10<sup>6</sup> sec.                      Input: Channels A and B.                      Accuracy: ±1 count = time base accuracy = trigger error.*                      Reads in: msec or sec with positioned decimal.                      Measurement: time from A to B.                      Self check: period self check below applies, when levels and slopes of both channels are identical.</p>	<p>Range: 10 μsec to 10<sup>7</sup> sec.                      Input: Channels A and B.                      Standard frequency counted: 1 MHz to 0.1 Hz in decade steps or external frequency 100 Hz to 1 MHz.                      Accuracy: ±1 count = time base accuracy = trigger error.*                      Reads in: msec or sec with positioned decimal.                      Measurement: time from A to B.</p>
Frequency	<p>Range: 0 to &gt;300 kHz.                      Input: Channel A.                      Accuracy: ±1 count = time base accuracy.                      Reads in: kHz or MHz with positioned decimal.                      Gate time: 10 μsec to 10 sec in decades.                      Self check: counts 100 kHz for the gate time chosen by time base selector.</p>	<p>Range: 0 to &gt;2 MHz.                      Input: Channel A.                      Accuracy: ±1 count = time base accuracy.                      Reads in: kHz or MHz with positioned decimal.                      Gate time: 10 μsec to 10 sec in decades.                      Self check: counts 1 MHz for the gate time chosen by time base selector.</p>
Period	<p>Range: 0 to 100 kHz.                      Input: Channel A.                      Accuracy: ±1 count = time base accuracy = trigger error.**                      Reads in: μsec or msec with positioned decimal.                      Frequency counted: 100 kHz to 0.1 Hz in decade steps.                      Self check: gate time is 1 sec; frequency counted is 0.1 Hz to 100 kHz as selected by time base switch.</p>	<p>Range: 0 to 100 kHz.                      Input: Channel A.                      Accuracy: ±1 count = time base accuracy = trigger error.**                      Reads in: msec or sec with positioned decimal.                      Frequency counted: 1 MHz to 0.1 Hz in decade steps.                      Self check: gate time is 1 sec, frequency counted is 0.1 Hz to 1 MHz as selected by time base switch.</p>
Period average	<p>Range: 0 to 300 kHz.                      Input: Channel A.                      Accuracy: ±1 count = time base accuracy = trigger error.**                      Reads in: μsec or msec with positioned decimal.                      Frequency counted: 100 kHz.                      Periods averaged: 10 to 10<sup>6</sup> in decade steps.                      Self check: gate time is 10 μsec to 10 sec (1 to 10<sup>6</sup> periods of 100 kHz); counts 100 kHz.</p>	<p>Range: 0 to 2 MHz (multiple period), 0 to 1 MHz (X10), 0 to 100 kHz (X1).                      Input: Channel A.                      Accuracy: ±1 count = time base accuracy = trigger error.**                      Reads in: μsec or nsec with positioned decimal.                      Periods averaged: 10 to 10<sup>7</sup> in decade steps.                      Frequency counted: 1 MHz.                      Self check: gate time is 10 μsec to 10<sup>6</sup> sec (10 to 10<sup>7</sup> periods of 1 MHz); counts 1 MHz.</p>
Ratio	<p>Range: Channel A (F<sub>A</sub>): 0 to above 300 kHz; Channel B (F<sub>B</sub>): 0 to 300 kHz (X10 to X10<sup>6</sup>), 0 to 100 kHz (X1).                      Input: Channels A and B.                      Measures: <math>\frac{F_A}{F_B}</math> (multiplier)                      Reads: <math>\frac{F_A}{F_B}</math> or <math>\frac{1000F_A}{F_B}</math>, depending on multiplier setting.                      Accuracy: ±1 count of F<sub>A</sub> = <math>\frac{\text{trigger error of } F_B}{\text{multiplier setting}}</math>                      Multiplier: 1 to 10<sup>6</sup> in decade steps.                      Self check: counts 100 kHz for 10 μsec to 10 sec, depending on multiplier setting.</p>	<p>Range: Channel A (F<sub>A</sub>): 0 to more than 2 MHz; Channel B (F<sub>B</sub>): 0 to 2 MHz (multiple period), 0 to 1 MHz (X10), 0 to 100 kHz (X1).                      Input: Channels A and B.                      Measures: <math>\frac{F_A}{F_B}</math> (multiplier)                      Reads: <math>\frac{F_A}{F_B}</math> or <math>\frac{1000F_A}{F_B}</math>, depending on multiplier setting.                      Accuracy: ±1 count of F<sub>A</sub> = <math>\frac{\text{trigger error of } F_B}{\text{multiplier setting}}</math>                      Multiplier: 1 to 10<sup>7</sup> in decade steps.                      Self check: counts 1 MHz for 10 μsec to 10 sec, depending on multiplier setting.</p>
Manual	<p>Input: Channel A.                      Multiplier: prescales input of Channel A in decades, 1 to 10<sup>6</sup>.                      Totalize: periodic events at rates to more than 3 × 10<sup>6</sup>/sec; random events with pulse spacing of 3.3 μsec or more.</p>	<p>Input: Channel A.                      Multiplier: prescales input of Channel A in decades, 1 to 10<sup>7</sup>.                      Totalize: periodic events at rates to more than 2 × 10<sup>6</sup>/sec; random events with pulse spacing to 0.5 μsec or less.</p>
Time base	<p>Frequency (internal): 100 kHz.                      Stability: aging rate: &lt;±2 parts in 10<sup>6</sup>/week; as a function of line voltage: &lt;±1 part in 10<sup>6</sup> for 10% changes in line; as a function of ambient temperature: &lt;±20 parts in 10<sup>6</sup> (+15°C to +35°C), &lt;±100 parts in 10<sup>6</sup> (-20°C to +65°C).                      External input: sensitivity: 1 V rms, sine wave into 1 K ohm; range: 100 Hz to 300 kHz, sine wave.                      Outputs, rear panel                      Oscillator: 100 kHz, 1 V peak to peak, open circuit; time base (separate BNC connector): 0.1 Hz to 100 kHz in decade steps, 5 V peak open circuit, 1 μsec width; 1000-ohm source; available in Period, Time Interval, and Manual without reset interruptions.</p>	<p>Frequency (internal): 1 MHz.                      Stability: aging rate: &lt;±2 parts in 10<sup>6</sup> per month; as a function of line voltage: &lt;±1 part in 10<sup>6</sup> for changes of ±10%; as a function of ambient temperature: &lt;±2 parts in 10<sup>6</sup> (+10°C to +30°C), ±20 parts in 10<sup>6</sup> (0°C to +65°C).                      External input: range: 100 Hz to 1 MHz, sine wave; sensitivity: 1 V rms above 1 kHz; 2 V rms, 100 Hz to 1 kHz.                      Outputs, rear panel                      Oscillator: 1 MHz, 5 V p-p; time base (separate BNC connector): 0.1 Hz to 1 MHz in decade steps, 5 V p-p, 600-ohm source; available in Period, Time Interval, and Manual without reset interruptions.</p>
Scaling	<p>Range: 0 to 300 kHz.                      Function setting: Manual.                      Input: Channel A.                      Factor: by decades up to 10<sup>6</sup>.                      Output: rear panel in place of time base output frequencies.</p>	<p>Range: 0 to &gt;2 MHz.                      Function setting: Manual.                      Input: Channel A.                      Factor: by decades up to 10<sup>7</sup>.                      Output: rear panel in place of time base output frequencies 5 V p-p from 600 ohms.</p>
General	<p>Printer output                      Output: 4-line 1-2-2-4 BCD, 100 K each line; "0" state level: approx. -28 V; "1" state level: -2 V.                      Reference levels: approx. -2.4 V, 350-ohm source impedance, and -26.9 V, 1000-ohm source.                      Print command: -28 V step from 2700-ohm source in series with 1000 pF.                      Hold-off requirements: chassis ground to +12 V maximum.                      Registration: 5 long-life rectangular digital tubes with display storage.                      Sample rate: time following a gate closing during which the gate may not be reopened is continuously variable from less than 0.2 sec to 5 sec; independent of gate time; display can be held indefinitely.                      Self check: in all function and multiplier positions.                      Operating temperature range: -20°C to +65°C.                      Power: 115 or 230 V ±10%, 50 to 60 Hz***; 40 watts.                      Dimensions: 16¼" wide, 3-15/32" high, 11¼" deep (425 x 86 x 28 mm).                      Weight: net 19 lbs (8.5 kg); shipping 22 lbs (10 kg).                      Price: HP 5223L, \$1275.                      Option 02: 1-2-4-8 BCD output ("1" state positive), in lieu of 1-2-2-4 BCD output, add \$10.†</p>	<p>Printer output                      Output: 4-line 1-2-2-4 BCD; 100 K each line; "0" state level: approx. -8 V; "1" state level: approx. +18 V.                      Reference levels: approx. +13 V, 900-ohm source impedance, and approx. -5 V, 1200-ohm source impedance.                      Print command: -28 V step, 2700-ohm source impedance; 1000 pF in series.                      Hold-off requirements: from -2 V to -20 V.                      Registration: 6 long-life rectangular digital tubes with display storage.                      Measurements unit: unit readout for frequency, period, period average, and time interval with positioned decimal point.                      Sample rate: time following a gate closing during which the gate may not be reopened is continuously variable from less than 0.2 sec to 5 sec; independent of gate time; display can be held indefinitely.                      Self check: in all function and multiplier positions.                      Operating temperature range: 0°C to +65°C.                      Power: 115 or 230 V ±10%, 50 to 60 Hz***; 50 watts.                      Dimensions: 16¼" wide, 3-15/32" high, 11¼" deep (425 x 86 x 285 mm).                      Weight: net 19 lbs (8.5 kg); shipping 22 lbs (10 kg).                      Price: HP 5233L, \$1600.                      Option 02: 1-2-4-8 BCD output in lieu of 1-2-2-4 BCD, add \$10.†</p>
<p>* For any wave shape, trigger error is less than <math>\frac{0.0025}{\text{signal slope (V/μsec)}} \mu\text{sec}</math>; below 0.1 Hz maximum error may increase up to 10-fold, depending on line voltage and environmental conditions.                      ** With trigger level set at zero, either slope, trigger error for sine wave input is less than <math>\frac{0.3\% \text{ of one period}}{\text{periods averaged}}</math> at rated sensitivity for signals with 40 dB signal-to-noise ratio.                      *** Line frequency limit imposed by cooling fan. † Option 03.—same as 02, except "1" state negative, add \$10.</p>		



## PRESET COUNTER

Normalizes data; controls, counts and times

Model 5214L

### Uses:

- Measures normalized rate
- Measures ratio
- Measures normalized ratio
- Measures time for N events to occur
- Counts N events, giving an output pulse at the start and the end of the count
- Allows N to be remotely preset  
(N may be set to any integer from 1 to 100,000)

Model 5214L Preset Counter is one of the most versatile electronic counters ever produced. It not only measures frequency and period and totalizes, as do most universal electronic counters, but it also performs the additional measurement functions enumerated under "Uses". Such versatility is achieved by using two sets of decades; one set registers the signal being counted, the other, which may be preset to any integer from 1 to 100,000, controls the gate. Provision has been made so that the number N can be remotely programmed. Separate output signals also are available to operate external equipment whenever the gate opens or closes. Solid state circuits are used throughout.

### Rate measurement

In rate measurements, which correspond to the frequency measurements of ordinary counters, gate time is controlled by the preset decades (N), the time base (100 kHz), and the multiplier (M). The gate is held open for N periods ( $N = 1$  to  $N = 100,000$ ) of the frequency furnished by the time base. If the internal 100 kHz time base is connected directly to the preset decades (M at X1), the gate time is set in 10  $\mu$ sec steps. Setting the Multiplier to X10 or X100 divides the time base frequency by 10 or 100 respectively, so that time may be set in 100  $\mu$ sec or 1 msec steps, as well. Setting gate time for 1 second permits frequency measurements directly in cycles per second.

Being able to select gate time allows you to normalize readings or to convert frequencies into practical units. For instance, if a tachometer generator, which produces 100 pulses per revolution, is connected to a rotating shaft, you can set the gate to 10,000 msec (0.01 sec) and measure rps directly or you can set the gate for 600.00 msec (0.6 sec) and measure rpm.

The long gate times that are available (up to 100 seconds) allow you to measure low frequencies or register the least significant digits of an input signal better to observe small variations of rate.

### Ratio measurement

Model 5214L measures ratio over a wide range of frequencies and with a wide choice of normalizing factors. The signal connected to input B goes through the Multiplier switch and the preset decades, and controls the gate time; the signal connected to input A goes to the readout decades. Consequently, signal A is counted for a number of periods of signal B equal to the product of N and the Multiplier setting.

The number displayed by the readout decades is MNA/

B, where A is the frequency of the signal connected to input A, and B is the frequency of the signal connected to input B. Gate length from 1 to  $10^7$  periods of signal B can be chosen in steps of 1, 10, or 100. Input B also can be used for extending gate time or for applications requiring an external time base.

### Time measurement

In the Time function, which corresponds to period measurements in conventional counters, the HP5214L measures the time in milliseconds for N events to occur. The measurement may be made in increments of 0.01, 0.1 or 1 msec by setting the Multiplier to X1, X10, or X100, respectively.

Period and multiple period measurements are also easily made with the function switch in the Time position, and period average is determined by dividing the time reading by N. The ability to choose the number of input cycles measured and to choose time increments of 0.01 msec, 0.1 msec, or 1 msec allows the operator to achieve the greatest accuracy possible, or to obtain a required accuracy in the shortest measurement time.

### Preset counting

When the Function switch is set to Preset at N, the 5214L counts N events and provides an output pulse at the beginning and end of the preset count. This feature is useful in batching, as the gate signal can be used to control external equipment. Separate electrical output signals are available at the beginning and end of the count.

### Display storage

All HP solid-state electronic counters have display storage which holds the most recent measurement even while the instrument is gated for a new count. If the new count differs from the stored count, the display will shift to the new reading directly. Where desirable, the storage feature may be disabled by a rear-panel switch.

### Electrical readout

These counters provide a four-line BCD code output with assigned weights of 1-2-2-4 ("1" state positive with respect to "0" state). This output is suitable for systems use or for output devices such as HP562A Digital Recorder, or the 580A, 581A Digital-to-Analog Converters (pages 96 and 98). 1-2-4-8 BCD code output is also available at extra cost.

### Specifications

#### Functions

##### Totalize (Input A)

Range: 2 Hz to 300 kHz.

Sensitivity: \*0.1 volt rms sine wave.

Gate time: manual control.

Input Impedance: 1 megohm, 50pF shunt.

Capacity: 99,999 counts in units, tens or hundreds.

##### Rate (Input A)

Range: 2 Hz to 300 kHz.

Sensitivity: \*0.1 volt rms sine wave.

Gate time: 10  $\mu$ sec to 1 sec in 10  $\mu$ sec steps; 100  $\mu$ sec to 10 sec in 100  $\mu$ sec steps; 1 msec to 100 sec in 1 msec steps.

Accuracy:  $\pm 1$  count  $\pm$  time base accuracy.

Input impedance: 1 megohm, 50pF shunt.



5214L

**Preset (Input A)**

Input frequency range: 2 Hz to 100 kHz.

Sensitivity\*: 0.1 V rms sine wave.

Reads: time for N events in msec.

Time units: 10  $\mu$ sec, 0.1 msec or 1 msec.

Input Impedance: 1 megohm, 50 pf shunt.

Accuracy:  $\pm 1$  count  $\pm$  time base accuracy  $\pm$  trigger error.†

**Ratio**

Input A: frequency range 2 Hz to 300 kHz; sensitivity, \*0.1 V rms sine wave; input impedance, 1 megohm, 50 pf shunt.

Input B: frequency range, 2 Hz to 100 kHz on X1 (2 Hz to 300 kHz on X10 and X100); sensitivity, 0.1 V to 10 V rms; input impedance, 1 megohm, 50 pf shunt.

Reads: N x A/B x Multiplier.

Accuracy:  $\pm 1$  count.

**Internal time base**

Aging rate:  $< \pm 2$  parts in  $10^6$  week.

Temperature:  $< \pm 20$  parts in  $10^6$   $+15^\circ\text{C}$  to  $+35^\circ\text{C}$ ;  
 $< \pm 100$  parts in  $10^6$   $-20^\circ\text{C}$  to  $+65^\circ\text{C}$ .

Line voltage:  $< 1$  part in  $10^6$  for  $\pm 10\%$  line.

**Printer output**

Output: 4-line 1-2-2-4 BCD; 1-2-4-8 BCD optional.

Impedance: 100 K each line; "0" state level: approx.  $-28$  V; "1" state level:  $-2$  V.

Reference levels: approx.  $-2.4$  V, 350-ohm source impedance and  $-26.9$  V, 1000-ohm source.

Print command: step from  $-29$  V to  $-1$  V from 2700-ohm source in series with 1000 pf.

Hold-off requirements: chassis ground to  $+12$  V max.

Remote operation: number "N" can be remotely preset by appropriate contact closures.

**General**

**Registration:** 5 long-life rectangular digital display tubes with display storage.

**Sample rate:** sample rate control determines length of time after gate closure before gate can be reopened; adjustable from 0.2 sec min. to at least 5 sec max. with counter in Rate, it is independent of gate time, and display can be held indefinitely.

**Input connectors:** BNC, on front and rear panels, wired in parallel.

**Operating temperature:**  $-20$  to  $+65^\circ\text{C}$ .

**Outputs:** positive pulse approx. 10 V high and 5  $\mu$ sec wide at gate opening and closing.

**Dimensions:** 16 $\frac{3}{4}$ " wide, 3-13/16" high, 13 $\frac{1}{4}$ " deep (426 x 97 x 337 mm); quickly converts to rack mount: 19" wide, 3 $\frac{1}{2}$ " high, 11 $\frac{1}{4}$ " deep behind mounting surface (483 x 89 x 286 mm).

**Weight:** net 15 lbs (6.75 kg); shipping 25 lbs (11 kg).

**Power:** 115 or 230 V  $\pm 10\%$ , 50 to 60 Hz, 35 W (line frequency limit imposed by fan motor).

**Accessories provided:** two 10503A cables, 4 feet long, BNC connectors, circuit board extender, detachable power cord.

**Price:** HP 5214L, \$1300.

**Options**

02. 1-2-4-8 BCD ("1" state positive) in lieu of 1-2-2-4, add \$10.

03. Same as Option 02. except "1" state negative, add \$10.

\* Internal control allows trigger adjustment for negative or positive periodic pulses.

† Trigger error (sine wave)  $< \frac{0.3\% \text{ of one period}}{N}$  for  $\geq 40$  dB signal-to-noise ratio on input signal; trigger error decreases with increased signal amplitude and slope.



## REVERSIBLE COUNTER

Counts up, down at 2 MHz rate; very versatile  
Model 5280A

The 5280A/5285A Reversible Counter/Plug-In combination has two input channels ("A" and "B") with an individual range of dc to more than 2 MHz. The superior trigger level controls for each channel allow the use of a wide range of inputs in all modes of operation. Drift of the differential dc amplifiers, used in the input circuitry, is unusually low to provide more accurate definition and retention of set trigger points.

Three basic types of measurement provide exceptional versatility.

### Algebraic A, B

**A:** The A input is totalized, dc to more than 2 MHz, for the length of time the main gate is open.

**A - B:** The input A minus the input B is totalized, dc to 1 MHz each channel, for the gate open period. In this mode the 1 MHz rate is retained while reversing direction of count, and while passing through zero.

**A + B:** The input A plus the input B is totalized, dc to 1 MHz each channel, for the gate open period.

**B:** The B input is totalized, dc to more than 2 MHz, for the length of time the main gate is open.

A directional MODE switch can be used to reverse the measurements in the above 4 modes, i.e.,  $-A$ ,  $-A+B$ ,  $-A-B$ , and  $-B$ . In the  $A-B$  and  $A+B$  modes, an anti-coincidence circuit is used to prevent the loss of any counts that arrive at the inputs in time coincidence.

### At(B)

In this mode of operation, A is counted forward when the B input is more positive than its trigger level setting, and A is counted in reverse when B is more negative than its trigger level. (Inverse operation is possible). A unique count direction gating system is used to prevent the inherent propagation delay down the readout decades from limiting the input frequency capability of A. The maximum input to channel A in this mode is 2 MHz even when the 7th and 8th digits have been added to the readout. The count direction can be reversed without count error with a minimum of 250 nsec between the reverse step function command and the next input pulse.

### A Quad B

This mode of operation is designed to operate with transducers having two outputs separated  $90^\circ$  in phase (in quadrature). The A output is totalized, up or down, depending upon its phase relationship with the B input. When B leads A, A is totalized in a positive direction; when B lags A, A is totalized in a negative direction. (Inverse operation is possible.) The direction of count may be reversed at a 1 MHz rate, which is also the maximum frequency allowable on A and B.

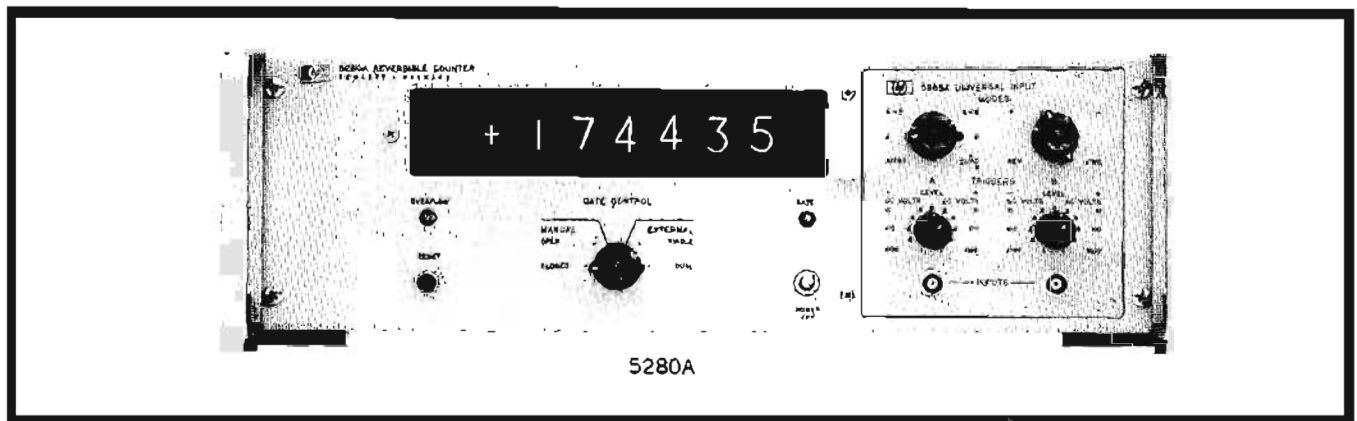

### Readout

Registration is by a 6-digit in-line display of rectangular Nixie tubes with a 7th and 8th digit of display available on request. Overflow of the displayed readout is indicated by a front panel neon light. A long-life Nixie displays + or - corresponding to the algebraic sign of the readout.

Four-line, BCD-coded output including polarity and overflow is provided as a standard feature with the assigned weights of 1-2-4-8 ("1" state positive with respect to the "0" state). This output is suitable for systems use, or for output devices such as the Hewlett-Packard Model 562A Digital Recorder, the HO3-580A and HO3-581A Digital-to-Analog Converters.

### Gating

Three gating modes are available, selected by a front panel switch. Manual "OPEN" and manual "CLOSED" operate the main gate for all functional modes of the plug-in operation. External "SINGLE" requires a dc voltage applied to a rear panel "START" input for the desired gate open period. In the external "DUAL" position separate inputs to two wires at the rear "START" "STOP" connectors are required to open and close the main gate. Reset may be accomplished by a front panel push button or by applying an input to a rear panel connector.

### 5285A Universal Input Plug-In

The 5285A Plug-In operates in conjunction with the 5280A Reversible Counter. Both units must be ordered; neither one will operate independently of the other.

## Typical Applications

- With laser interferometer for precision metrology.
- With flow meters to measure and control liquid flow rates or volume in a tank.
- With rotary optical encoders to measure and control position and velocity, for example, of rolls of paper.
- For crystal frequency comparison in production testing.
- With optical encoders or stepping motors to indicate position of numerically controlled machine tools.
- With V to F converters to integrate dc voltages and thus obtain the average value of drift over a time period.

## Specifications

### 5280A Reversible Counter

#### General

- Range:** dc to 2 MHz Channel A or Channel B (see 5285A specifications for details concerning other input requirements).
- Registration:** 6 long-life rectangular Nixie® tubes (7th and 8th digit of readout optional). + and - indication by long-life rectangular Nixie tube. Overflow indication by front panel neon light.
- Reset:** remote by contact closure or saturated NPN transistor to ground. Input via rear panel BNC. Manual by front panel pushbutton.
- Reset time:** less than 10  $\mu$ sec.
- Inhibit:** start channel is inhibited during reset time with the function switch in the DUAL position only. Inhibit released at end of reset time.
- Gate light:** gate light indicates main gate open.

#### Gate control

- Manual:** controlled by front panel function switch for OPEN and CLOSED positions.

#### External dual

- Input:** separate BNC's on rear panel for START and STOP inputs
- Sensitivity:** sine wave 1 volt rms; pulse 2 V p-p.
- Impedance:** approximately 100 k ohms, 25 pF in shunt.
- Trigger level:** +10 volts to -10 volts, adjustable at the rear panel. Independent controls on each input.
- Polarity:** + or - rear panel switch selects triggering slope.

#### External single

- Input:** START BNC on rear panel.
- Sensitivity:** sine wave 1 volt rms; pulse 2 V p-p.
- Impedance:** approximately 100 k ohms, 25 pF in shunt.
- Trigger level:** +10 volts to -10 volts, adjustable at rear panel.
- Polarity:** + or - rear panel switch selects gate open polarity.
- Gate:** (+) opens when input is positive with respect to the trigger level. Closes when input is negative with respect to the trigger level. (-) inverse of (+). Manually switched dc voltage is a satisfactory gating input.

#### Printer output

- Output:** 4-line 1-2-4-8 BCD.
- "0" state level: approximately -14 volts.
- "1" state level: approximately +14 volts.
- Impedance:** 100 k ohms each line.
- Reference levels:** 0 volts for "0" and "1" states.
- Print command:** positive 15-volt step from -15 volts to 0 volts.
- Hold-off requirements:** externally applied level change from 0 volts or more negative than 0 volts to +10 volts (effective with function switch in DUAL position only).
- Overflow:** single line output, 100 k ohms impedance. "OFF" level approximately +17 volts, "ON" level approximately -13 volts.
- ± Nixie sign (indicates sign of count):** single line output, 100 k ohms, impedance, + level approximately -15 volts. - level approximately +13 volts.

#### Physical specifications

- Rear panel connectors:** BNC "START" and "STOP" gate inputs. BNC rear terminal in parallel (RTIP) inputs for "A" and "B" channels of the 5285A Universal Input plug-in. BNC input for external RESET. BNC MONITOR outputs for channel A and B triggers. 50 pin mating connector for BCD output. Ampphenol # 57-30500-375 (HP # 1251-0086).

©Burroughs Corp.

## Special Orders and Options

A special order time base allows precise setting of the gating period in 1 msec increments up to a total of 1000 secs. Gate time set by thumb wheels on front panel. Decade steps optional. Variable sample rate; hold provision.

A "Readout on the Fly" feature (special order) enables the count to be transferred into a storage register on command at any point in time without interrupting counting. The sample rate for transferring data is in excess of 100 kHz.

1-2-2-4 coded digital output is available as an option. For details, please communicate with your HP field office.

**Rear panel controls:** ± polarity switch for single and dual gate control input. Trigger level adjustments for "START" "STOP" inputs, ± 10 volts.

**Dimensions:** 5¼" high, 16¾" wide, 16⅞" deep (132 x 425 x 416 mm).

**Weight:** Net, 29 lbs (13.2 kg). Shipping, 40 lbs (18.1 kg). (Weights include plug-in.)

**Power:** 115 or 230 volts ± 10%, 50 to 60 Hz, 110 watts (with 5285A plug-in).

**Operating temperature range (5280A/5285A):** 0°C (32°F) to +65°C (+149°F).

**Price:** \$1450.

### 5285A Universal Input Plug-In

(for operation in HP Model 5280A only)

#### Input channels (A and B)

**Range:** dc coupled: 0 to more than 2 MHz. ac coupled: 10 Hz to more than 2 MHz.

**Impedance:** approximately 1 megohm, 75 pF shunt.

**Maximum input:** ac coupled, ± 600 volts peak; dc coupled, 25 volts rms (X1), 150 volts rms (X10), 350 volts rms (X100).

**Sensitivity:** 0.1 volt rms sine wave; 1 volt pulse, 0.2  $\mu$ sec minimum width.

**Trigger level:** -100 to +100 volts, adjustable, independent controls on each channel.

#### Modes of operation

**A Quad B:** totalizes A as a function of B phase. Maximum rate 1 MHz (same frequency in both channels).

Totalizes A positively if B leads A.

Totalizes A negatively if B lags A.

(Above for directional MODE switch in FWD position. Count direction reversed with switch in REV position.)

**Af(B):** totalizes A as a function of B from dc to more than 2 MHz. If B is positive, A is totalized positively. If B is negative, A is totalized negatively. Count direction reversed within 250 nsec of B step function command. (Direction of A counted as a function of B is reversed with directional MODE switch in REV position.)

**Algebraic A, B:** totalizes both A and B according to MODE selector setting.

**A:** A only to greater than 2 MHz.

**A-B:** input A minus input B; to 1 MHz per channel. Anti-coincidence circuit prevents count loss when pulses arrive in time coincidence.

**A+B:** input A plus input B; 1 MHz per channel. Anti-coincidence circuit prevents count loss when pulses arrive in time coincidence.

**B:** B only to > 2 MHz.

Direction of counting is reversed with the directional MODE switch in - position, i.e., modes would be -A -A+B, -A-B, -B.

#### Physical specifications

**Weight:** Net, 3 lbs (1.4 kg). Shipped in 5280A.

**Dimensions:** 4-25/64" high, 4-37/64" wide, 8½" deep (112 x 116 x 216 mm).

**Price:** \$450.





## ELECTRONIC COUNTERS

Measure frequency to 10.1 MHz; stable time base  
Models 524C,D

The HP 524C and 524D Electronic Counters (vacuum tube models) permit direct measurement of frequency and period from 10 Hz to 10 MHz and dc to 100 kHz, respectively. High accuracy is assured by a crystal time base, stable to within  $\pm 5$  parts in  $10^8$  per week.

Plug-in versatility permits frequency measurement range to be extended upward to 510 MHz, allows period measurements over 10,000 periods, provides increased sensitivity for measurement of low-level signals and adds time interval measurement capability. When used with the HP 2590A Microwave Frequency Converter, frequency range can be extended to 15 GHz. The HP 540B Transfer Oscillator with P932A Harmonic Mixer extends the range to 18 GHz. Typical applications include measurement of transmitter and crystal oscillator frequencies, electrical and mechanical time intervals, pulse length and repetition rates, frequency drift, phase angle, high-accuracy ballistic timing and high-resolution tachometry. The 524 also is very useful as a secondary frequency.

Frequency is read over 5 selected gate times — 0.001, 0.01, 0.1, 1 and 10 seconds. Period of time interval is measured by counting accurate, internally generated, standard frequencies of 10 Hz, 1 or 100 kHz, 10 MHz, or an externally applied frequency. Display time is variable at will; counts are automatically reset, and action is repetitive.

### Specifications, 524C,D

(basic unit for frequency measurements, 0 Hz to 10.1 MHz)

#### Frequency measurement (without plug-in units)

**Range:** 10 Hz to 10.1 MHz.

**Gate time:** 0.001, 0.01, 0.1, 1, 10 seconds or manual control.

**Accuracy:**  $\pm 1$  count  $\pm$  time base accuracy.

**Reads in:** kHz; decimal point automatically positioned.

#### Period measurement (without plug-in units)

**Range:** 0 Hz to 100 kHz.

**Gate time:** 1 or 10 cycles of unknown.

**Accuracy:**  $\pm 1$  count  $\pm$  time base accuracy  $\pm$  trigger error.

**Standard frequency counted:** 10 Hz, 1 kHz, 100 kHz, 1 MHz, 10 MHz, or externally applied frequency.

**Reads in:** sec, msec or  $\mu$ sec; decimal point automatically positioned.

#### General

**Registration (99,999,999 maximum display):** 524C, 8 places (in-line digital display tubes); 524D, 8 places (neon columnar).

**Stability:**  $\pm 5$  parts in  $10^8$  per week,  $\pm 3$  parts in  $10^8$  short-term; external 100 kHz or 1 MHz primary standard may be used.

**Display time:** variable 0.1 to 10 seconds but not less than gate time; display can be held indefinitely.

**Output frequencies:** secondary standard frequencies available at front panel: 10 Hz, 1 kHz rectangular; 100 kHz positive pulse; 10 MHz sine wave (stability as above).

**Crystal oven:** temperature monitored by dial thermometer.

**Self check:** panel control provides automatic count of internal standard 100 kHz and 10 MHz frequencies to assure accuracy of gate and proper operation of counter.

**Input voltage:** 1 V rms min.; 1.5 V peak; rise time 0.2 sec or faster.

**Input impedance:** approx. 1 megohm, 40 pF shunt capacitance.

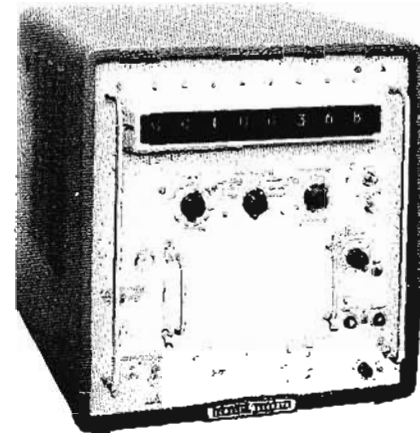

524C Electronic Counter



525A — extends frequency measurement range from 10 MHz to 100 MHz.



525B — permits frequency measurements in 100 to 220 MHz range.

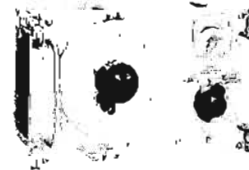

525C — enables counter to measure frequency between 100 MHz and 510 MHz.



526A — increases 524 sensitivity to 10 mv.

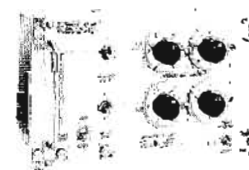

526B — provides time interval measurement capabilities — 1  $\mu$ sec to 100 days.



526C — allows accurate low-frequency multiple period measurements to  $10^4$  periods averaged.



526D — converts counter to make precise, direct phase angle measurements.

**External standard:** 100 kHz or 1 MHz signal from external primary standard can be applied to unit for highest accuracy; 2 volts rms required; input impedance, nominal: 56 K, 40 pF shunt.

**Connectors:** BNC type.

**Power:** 115 or 230 V  $\pm$  10%, 50 to 60 Hz, approx. 600 W.

**Accessories furnished:** 10503A Cable Assembly, 48" RG-58/U cable, terminated each end with UG-88/U BNC male connectors.

**Dimensions:** cabinet: 20" wide, 21 $\frac{1}{4}$ " high, 23 $\frac{1}{2}$ " deep (508 x 540 x 597 mm); rack mount: 19" wide, 19 $\frac{1}{4}$ " high, 20 $\frac{1}{4}$ " deep (483 x 489 x 514 mm).

**Weight:** net 118 lbs (53 kg), shipping 155 lbs (69 kg) (cabinet); net 108 lbs (49 kg), shipping 153 lbs (69 kg) (rack mount).

**Price:** HP 524C, \$2900 (cabinet); HP 524CR, \$2900 (rack mount); HP 524D, \$2650 (cabinet); HP 524DR, \$2650 (rack mount); with 4-line (1-2-2-4 "1" state positive); BCD output and reference voltage for driving 562A Digital Recorder, price on request.

#### Options

01. Single-line voltage coded decimal output (staircase) for operating 560A Digital Recorder; 524D-95A installed, add \$60 (MS 3102A-22-14S output connector).

02. 10-line decimal code output and 562A-16C Cable for operating 561B Digital Recorder or remote indicator; 524C-95B installed (524C, CR only), add \$165 (Amphenol 57-20500 output connector).

### 525A Frequency Converter Unit

(plugged into 524 Electronic Counter)

**Range:** as amplifier, 10 Hz to 10.1 MHz; as converter, 10.1 MHz to 100 MHz.

**Accuracy:** retains accuracy of counter.

**Resolution:** 0.1 cycle to 1000 cycles, depending on gate time.

**Input voltage:** 0.1 volt to 10 volts rms, 10 Hz to 10 MHz; 10 mV to 1 volt rms, 10 MHz to 100 MHz.

**Input impedance:** approximately 1 megohm shunted by 40 pF; 10 Hz to 10 MHz; approximately 50 ohms, 10 MHz to 100 MHz.

**Tuning indicator:** tuning eye aids frequency selection, indicates correct voltage level adjustment.

**Weight:** net 5 lbs (2 kg); shipping 9 lbs (4 kg).

**Price:** HP 525A, \$350.

### 525B Frequency Converter Unit

(plugged into 524 Electronic Counter)

**Range:** 100 MHz to 220 MHz.

**Accuracy:** retains accuracy of counter.

**Resolution:** 0.1 cycle to 1000 cycles, depending on gate time.

**Input voltage:** 0.2 volt rms minimum.

**Input impedance:** approximately 50 ohms.

**Tuning indicator:** tuning eye aids frequency selection, indicates correct input voltage.

**Weight:** net 5 lbs (2 kg); shipping 9 lbs (4 kg).

**Price:** HP 525B, \$425.

### 525C Frequency Converter Unit

(plugged into 524 Electronic Counter)

**Range:** as converter for counter, 100 MHz to 510 MHz; as amplifier for counter, 50 kHz to 10.1 MHz; direct connection for 0 to 10.1 MHz.

**Accuracy:** retains accuracy of counter.

**Resolution:** 0.1 cycle to 1000 cycles, depending on gate time.

**Input voltage:** 20 mV rms minimum, 50 kHz to 10.1 MHz; 100 mV rms minimum 100 to 510 MHz.

**Maximum input:** 2 V rms from 50 kHz to 10.1 MHz and 100 to 510 MHz.

**Input impedance:** approximately 700 ohms, 50 kHz to 10.1 MHz; approximately 50 ohms, 100 MHz to 510 MHz.

**Level indicator:** meter aids frequency selection, indicates usable voltage level.

**Weight:** net 7 lbs (3 kg); shipping 10 lbs (5 kg).

**Price:** HP 525C, \$475.

### 526A Video Amplifier Unit

(plugged into 524 Electronic Counter)

**Range:** 10 Hz to 10.1 MHz.

**Accuracy:** retains accuracy of counter.

**Minimum input voltage:** approximately 10 mV rms.

**Level control:** meter indicates input signal level, correct voltage adjustment.

**Output terminal:** BNC connector provides 10 times input voltage from 93-ohm source on the most sensitive range; allows oscilloscope monitoring of input signal without loading circuit.

**Reads in:** same as basic 524 Counter.

**Accessories furnished:** supplied with 10505A Probe Assembly, which increases input impedance to 10 megohms shunted by 15 pF; maximum sensitivity using probe is 0.1 volt rms.

**Weight:** net 5 lbs (2 kg); shipping 8 lbs (3 kg).

**Price:** HP 526A, \$250.

### 526B Time Interval Unit

(plugged into 524 Electronic Counter)

**Range:** 1  $\mu$ sec to 10<sup>7</sup> seconds.

**Accuracy:**  $\pm$  1 period of standard frequency counted,  $\pm$  time base accuracy.

**Registration:** on 524 Counter.

**Input voltage:** 1 volt peak minimum, direct-coupled input.

**Input impedance:** approximately 1 megohm, 40 pF shunt.

**Start-stop:** independent or common channels.

**Trigger slope:** positive or negative on start and/or stop channels.

**Trigger amplitude:** both channels continuously adjustable from -192 to +192 volts.

**Standard frequency counted:** 10 Hz, 1 or 100 kHz, 10 MHz from 524 counter; or externally applied frequency.

**Reads in:** sec, msec or  $\mu$ sec; decimal point automatically positioned.

**Accessory furnished:** 10503A Cable Assembly, 48" RG-58C/U cable terminated with UG-88/U BNC connectors.

**Weight:** net 5 lbs (2 kg); shipping 7 lbs (3 kg).

**Price:** HP 526B, \$275.

### 526C Period Multiplier Unit

(plugged into 524 Electronic Counter)

**Range:** 0 to 100 kHz.

**Gate time:** 1, 10, 100, 1000, and 10,000 cycles of the unknown frequency.

**Accuracy:**  $\pm$  1 count  $\pm$  time base accuracy  $\pm$  trigger error.

**Standard frequency counted:** 10 Hz, 1 kHz, 100 kHz, 10 MHz or externally applied frequency.

**Reads in:** seconds, milliseconds, microseconds.

**Input voltage:** 1 volt rms minimum.

**Input impedance:** 1 megohm, 40 pF shunt.

**Weight:** net 5 lbs (2 kg); shipping 7 lbs (3 kg).

**Price:** HP 526C, \$250.

### 526D Phase Unit

(plugged into 524 Electronic Counter)

**Range:** phase angle, 0 to 360° lead or lag.

**Frequency range:** 1 Hz to 20 kHz.

**Reads in:** time units with maximum resolution of 0.1  $\mu$ sec for full frequency range; for frequencies 396 to 404 Hz, a frequency multiplier (3600X) provides readings direct in tenths of degrees.

**Accuracy:**  $\pm (0.5^\circ + \frac{F_p}{F_c} \times 360^\circ + F_p \times 10^{-6} \times 360^\circ)$  where  $F_p$  is

frequency of phase measured signal, and  $F_c$  is counted frequency ... assuming noise 65 dB below signal and negligible counted frequency error; S/N ratio influences accuracy; accuracy diminishes somewhat below 350 Hz when ac coupled; for highest accuracy both inputs should be coupled in the same mode, ac or dc.

**Input voltages:** 5 to 120 volts rms; usable to 240 V rms.

**Input impedance:** approximately 1 megohm, 80 pF shunt.

**Weight:** net 5 lbs (2 kg); shipping 10 lbs (5 kg).

**Price:** HP 526D, \$850.



## ELECTRONIC COUNTERS

Measure period, time or freq., 10 Hz to 1.2 MHz  
Models 522B, 523C,D

### Uses:

- Measure frequency
- Count periodic or random pulses
- Measure period, time interval
- High-accuracy phase measurements
- Totalize events, measure ratios
- Ballistic measurements

### 523C,D Electronic Counters

High sensitivity and versatile trigger level circuitry make the HP 523C and 523D Electronic Counters (vacuum tube models) useful for a broad range of applications. The instruments measure frequency, period, time interval, phase delay, random events and ratios. They also totalize electrical events, periodic or random. The 523C has an in-line display, while the 523D has a neon columnar display. Digital recorder output is optionally available on both instruments.

### Specifications, 523C,D

#### Frequency measurement

**Range:** 10 Hz to 1.2 MHz.

**Accuracy:**  $\pm 1$  count  $\pm$  time base accuracy.

**Input sensitivity:** 0.1 V rms, adjustable to 150 V rms maximum input.

**Input trigger levels:** stop channel may be used so that only signals meeting conditions set by trigger level controls are counted; slope may be + or -.level -300 to +300V.

**Input impedance:** approximately 1 megohm, 50 pF shunt.

**Gate time:** 0.001, 0.01, 0.1, 1, 10 seconds.

**Reads In:** kHz; automatic illuminated decimal point.

#### Period measurement

**Range:** 0.00001 Hz to 100 kHz.

**Accuracy measuring sine waves:**  $\pm 1$  count  $\pm$  time base accuracy  $\pm$  trigger error.

**Input requirements:** 0.1 V rms minimum, direct-coupled.

**Input impedance:** approx. 1 megohm shunted by 50 pF.

**Measurement period:** 1 or 10 cycles of unknown.

**Standard frequency counted:** 1 Hz to 1 MHz in decade steps or externally applied signal, 10 Hz to 1.2 MHz, 0.1 V rms minimum.

**Reads In:** seconds, msec or  $\mu$ sec, positioned decimal point.

#### Time interval measurement

**Range:** 1  $\mu$ sec to  $10^6$  sec.

**Accuracy (pulse input):**  $\pm 1$  count  $\pm$  time base accuracy.

**Input impedance:** approximately 1 megohm, 50 pF shunt.

**Input requirements:** 0.1 V rms minimum; direct- or ac-coupled input.

**Start and stop input:** separate channels with independent controls; separate or common input.

**Start and stop marker output:** separate output pulses, each approximately 5  $\mu$ sec duration and -20 V peak, available at rear of instrument for oscilloscope intensity modulation to mark start and stop points on input waveform; may be combined with Sep-Com switch on rear of instrument.

**Trigger slope:** pos. or neg. on start and stop channels.

**Trigger amplitude:** continuously adjustable on both input channels from -300 to +300 V.

**Standard frequency counted:** 1 Hz, 10 Hz, 100 Hz, 1 kHz, 10 kHz, 100 kHz, 1 MHz; external.

**Reads In:** seconds, msec or  $\mu$ sec; positioned decimal point.

#### Phase measurement

**Range:** 1 Hz to 20 kHz, dc coupled; 50 Hz to 20 kHz, ac coupled.

**Input voltage:** 5 to 10 V rms, pure sinusoidal signal.

**Accuracy:**  $\pm 0.1^\circ \pm \left( \frac{f_p}{f_c} \right) \times 360^\circ$  where  $f_c$  is the counted frequency and  $f_p$  the measured frequency.

**Ratio measurement:** displays  $f_1/f_2$ , or  $10 f_1/f_2$ , with accuracy of  $\pm 1$  count;  $f_1$ , 10 Hz to 1.2 MHz;  $f_2$ , 0.00001 Hz to 100 kHz ( $f_1 > f_2$ ).

**Totalize:** electrical events, periodic or random to 999999 at rates to 1,200,000/sec.

#### General

**Registration:** 523C, six in-line digital tubes, single line; 523D, six decimal places each indicated by lighted numbers.

**Stability:**  $2 \times 10^{-6}$  per week.

**Display time:** variable from approximately 0.1 to 10 seconds; display can be held until manually reset.

**Self-check:** counts of 100 kHz or 1 MHz.

**Output frequencies:** available at front panel; 1 Hz, 10 Hz, 100 Hz, 1 kHz, 10 kHz rectangular; 100 kHz and 1 MHz sine wave, 0.5 V p-p; stability  $2/10^6$  per week.

**External standard:** 100 kHz from external primary standard can be applied to unit for highest accuracy; minimum input, 1 V rms.

**Power:** 115 or 230 V  $\pm 10\%$ , 50 to 60 Hz, approx. 350 W.

**Dimensions:** cabinet, 20 $\frac{1}{2}$ " wide, 11 $\frac{1}{4}$ " high, 18 $\frac{3}{4}$ " deep (521 x 286 x 476 mm); rack mount: 19" wide, 8 $\frac{3}{4}$ " high, 16 $\frac{1}{4}$ " deep (483 x 222 x 413 mm).

**Weight:** net 48 lbs (22 kg), shipping 78 lbs (35 kg) (cabinet); net 48 lbs (22 kg), shipping 61 lbs (28 kg) (rack mount).

**Accessories furnished:** two 10503A Cable Assemblies.

**Accessories available:** remote indicator for 523C, 523CR and interconnecting cable (100' maximum), prices on request.

**Digital recorder kits for field installation:** 523D-95A Adapter Kit for operating 560A Digital Recorder from 523C or 523D, \$45; 523C-95B Adapter Kit for operating 561B Digital Recorder from 523C, \$65.

**Price:** HP 523C, \$1950 (cabinet); HP 523CR, \$1950 (rack mount); HP 523D, \$1700 (cabinet); HP 523DR, \$1700 (rack mount).

#### Options

01. Single-line decimal code (staircase) for operating 560A Digital Recorder, add \$45.
02. 10-line decimal code output for operating 561B Digital Recorder or remote indicator, 523C only, add \$65.

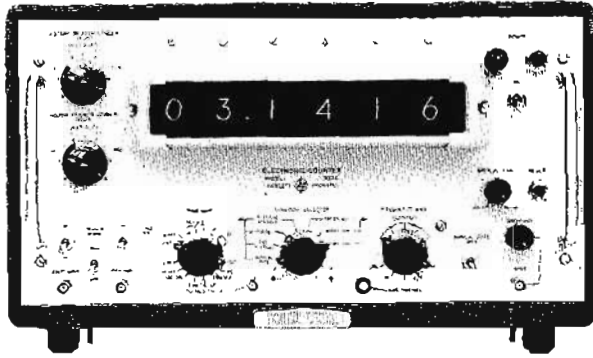

523 C  
10 Hz to 1.2 MHz

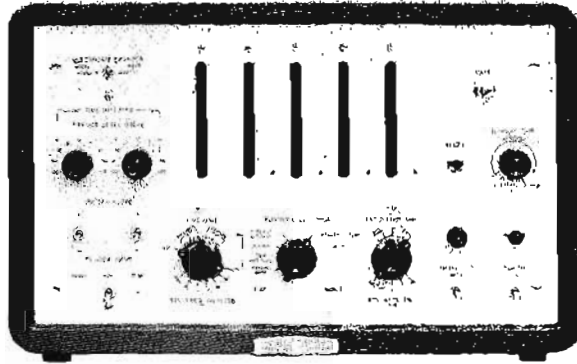

522 B  
10 Hz to 120 kHz

#### Special output

Four-line BCD output (1-2-2-4, "1" state positive) available for driving 562A Digital Recorder; 580A, 581A Digital-to-Analog Converters; Dymec instruments, or data processing equipment, prices on request.

### 522B Electronic Counter

*Versatile, low-cost precision counter covers 10 Hz to 120 kHz* — The all-purpose HP 522B Counter vacuum tube model measures frequency, period and time interval. Results are displayed automatically in direct-reading form — Hz, kHz, seconds or milliseconds. Reliable and accurate readings make measurement quick and convenient, even for unskilled personnel. The counter can be supplied with digital recorder output for a small additional charge.

#### Specifications, 522B

##### Frequency measurement

**Range:** 10 Hz to 120 kHz (220 kHz optional).

**Accuracy:**  $\pm 1$  count  $\pm$  time base accuracy.

**Stability:**  $1/10^5$ /week or better.

**Input requirements:** 0.2 volt rms minimum; input is direct-coupled (0.5 V rms above 120 kHz with 220 kHz option).

**Input impedance:** approximately 1 megohm, 50 pF shunt.

**Gate time:** 0.001, 0.01, 0.1, 1, 10 sec; manual control extends to any multiple of 1 or 10 sec.

**Display time:** variable 0.1 to 10 sec in steps of gate time selected or until manually reset.

**Reads in:** Hz or kHz, decimal point indicated.

##### Period measurement

**Range:** 0.00001 Hz to 10 kHz; output pulse available to actuate trigger circuit for mechanical register.

**Accuracy:**  $\pm 1$  count  $\pm$  time base accuracy  $\pm$  trigger error.

**Input requirements:** 0.2 V rms min.; direct-coupled input.

**Input impedance:** approximately 1 megohm, 50 pF shunt.

**Gate time:** one or ten cycles of unknown frequency; may be extended to any number of cycles of unknown frequency lower than 50 Hz by manual control.

**Standard frequency counted:** 1, 10, 100 Hz; 1, 10, 100 kHz; external.

**Display time:** variable from 0.1 to 10 seconds in steps of period being measured or until manually reset.

**Reads in:** seconds or msec, decimal point indicated.

##### Time interval measurement

**Range:** 10  $\mu$ sec to 100,000 seconds (27.8 hrs.).

**Accuracy:**  $\pm 1$  count  $\pm$  time base accuracy.

**Input requirements:** 1 V peak min.; direct-coupled input.

**Input impedance:** approx. 250,000 ohms, 50 pF shunt.

**Start and stop:** independent or common channels.

**Trigger slope:** + or - on start and/or stop channels.

**Trigger amplitude:** continuously adjustable on both channels from -100 to +100 volts.

**Standard frequency counted:** same as for period measurement.

**Display time:** same as for period measurement.

**Reads in:** seconds or msec, decimal point indicated.

##### General

**Power:** 115 or 230 V  $\pm 10\%$ , 50 to 60 Hz, 260 W.

**Dimensions:** cabinet: 20 $\frac{3}{4}$ " wide, 12 $\frac{3}{4}$ " high, 14 $\frac{1}{4}$ " deep (527 x 324 x 362 mm); rack mount: 19" wide, 10 $\frac{1}{2}$ " high, 13 $\frac{3}{8}$ " deep (483 x 267 x 346 mm).

**Weight:** net 50 lbs (22 kg), shipping 59 lbs (26 kg) (cabinet); net 44 lbs (20 kg), shipping 57 lbs (25 kg) (rack mount).

**Price:** HP 522B, \$1100 (cabinet); HP 522BR, \$1100 (rack mount); with staircase output (for 560A operation) specify Option 01., add \$45. For 220 kHz operation, specify Option 02., add \$35; BCD output (1-2-2-4) available, price on request.



## INDUSTRIAL COUNTERS

Low cost, flexible, easy use; 1 Hz to 1.2 MHz  
521 Series

Frequency, speed and random events, such as nuclear phenomena, occurring over a preselected time, are measured quickly and accurately by any one of the five low-cost electronic counters in the Hewlett-Packard 521 Series (vacuum tube models).

When connected to a suitable transducer that converts mechanical events into electrical pulses, the electronic counters measure weight, pressure, temperature, rps, rpm and other quantities that can be related to frequency.

Adapting the 521 Electronic Counters for recorder operation is conveniently done by the use of an adapter kit, installed by either the factory or the customer. It allows a permanent record of information to be acquired through some appropriate Hewlett-Packard digital recorder — 560A (staircase) or 561B (10-line) (page 97), or 562A (BCD) (page 96)—for analysis or future reference. Additionally, the kit provides compatibility between the counters and the 580A and 581A Digital-to-Analog Converters (page 98), so that chart recorders may be used for analog recordings of frequency drift or other type of signal source variation.



HP Model	521A	521C	521D	521E	521G
Maximum frequency	120 kHz (220 kHz with Option 03.)	120 kHz (220 kHz with Option 03.)	120 kHz (220 kHz with Option 03.)	120 kHz (220 kHz with Option 03.)	1.2 MHz
Accuracy	±1 count, ± line accuracy, approx. 0.1% (0.01% with Option 04.)	±1 count, ±0.01%	±1 count, ± line accuracy, approx. 0.1% (0.01% with Option 04.)	±1 count, ±0.01%	±1 count, ± line accuracy, approx. 0.1% (0.01% with Option 04.)
Registration	4 places, neon display capacity: 9,999	5 places, neon display capacity: 99,999	4 places, digital display capacity: 9,999	5 places, digital display capacity: 99,999	5 places, neon display capacity: 99,999
Gate time	0.1, 1 second, manual, ext.	0.1, 1, 10 seconds, manual, ext.	0.1, 1 second, manual, ext.	0.1, 1, 10 seconds, manual, ext.	0.1, 1 second, manual, ext.
Power	115 or 230 V, 50 to 60 Hz, approx. 160 W on 115-volt line (add 10 W for crystal time base unit)				
Size (cabinet)	9¼" wide, 15¼" high, 14¼" deep (248 x 387 x 362 mm)		9¼" wide, 15¼" high, 15½" deep (248 x 387 x 394 mm)		9¼" wide, 15¼" high, 14¼" deep (248 x 387 x 362 mm)
Price: cabinet or rack mount	\$650	\$800	\$900	\$1125	\$750

**Input:** 0.2 volt, rms, minimum, or output from 1P41 Phototube (or equal); 0.5 volt rms required at frequencies above 120 kHz with 220 kHz (Option 03.); continuously adjustable control for reducing sensitivity to overcome noise.

**Input impedance:** approximately 1 megohm, 50 pF shunt (500 k for "Phototube Jack").

**Display time:** variable from gate time to approximately 15 seconds, or until manually reset.

**Reads in:** Hz and rps or rpm with 506A or 508A Tachometer accessories (page 69).

**Weight:** net 28 lbs (13 kg), shipping 37½ lbs (17 kg) (cabinet); net 26 lbs (12 kg), shipping 41½ lbs (19 kg) (rack mount).

**Accessory provided:** 10501A Cable Assembly, 44" (RG/58C/U terminated on one end only with UG-88/U type BNC connector).

**Options:** (factory installed or kit form)

01. Adapter for 560A Digital Recorder operation (staircase), all models, add \$45; for field installation order Kit No. 521D-95A, \$45.
02. Adapter for 561B Digital Recorder operation (10-line) for 521D and 521E, add \$45; for field installation order Kit No. 521D-95B, \$45.
03. For 220 kHz operation for 521A,C,D,E, add \$35 (installed).
04. Crystal time base (100 kHz) plug-in for 521A,D,G, add \$100; for field installation order Kit No. 521C-59B, \$100.

**Modifications:** BCD output (1-2-2-4) for use with 562A Digital Recorder, 580A, 581A Digital-to-Analog Converters; price on request.

## TIME INTERVAL COUNTER

Measure intervals from 10 nanosec to 0.1 sec.  
Model 5275A



## FREQUENCY

Model 5275A is ideally suited for precise digital measurements of short time intervals between events that can be represented by suitable electrical pulses. Resolution to 10 nanoseconds is achieved in automatic measurements over the full 10 nsec to 0.1 sec range of the instrument.

Counted frequency is 100 MHz, obtained from an external 1 MHz standard by a multiplying circuit within the counter. Applications for this instrument include the measurement of explosive burning rates, speed and acceleration timing of test vehicles in the free-flight wind tunnels, and nuclear measurements of various kinds.

Rugged, modular construction and solid-state components

contribute to the typical HP quality and reliability of this remarkable instrument. Standard features of remote reset, rear-mounted trigger terminals and 4-line BCD output make the 5275A suitable for many applications that would otherwise require equipment of special design. The time interval counter is housed in the HP cabinet configuration which allows easy convertibility from bench use to rack mount.

For system installation HP 101A 1 MHz Oscillator (See Frequency, Time Standards) is capable of supplying the time base for as many as twenty 5275A Time Interval Counters. Using one frequency standard conserves valuable rack space and reduces system cost where several time interval counters are required.

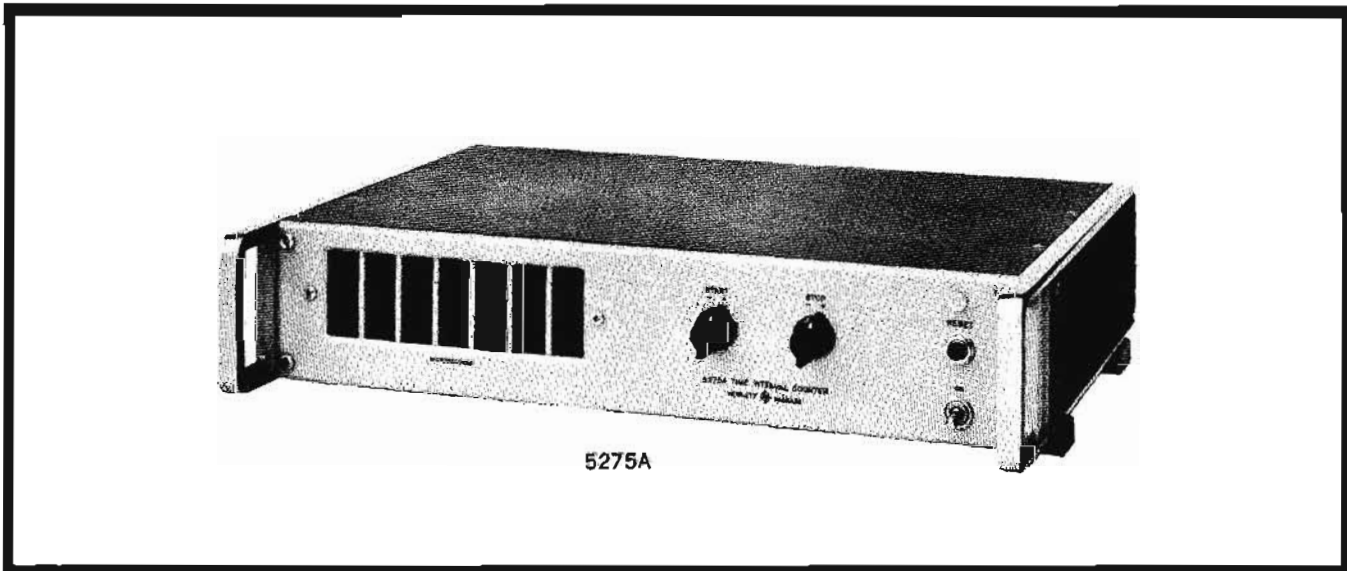

5275A

### Specifications

**Range:** 10 nanoseconds to 0.1 second.  
**Resolution:** 10 nanoseconds.  
**Accuracy:**  $\pm 10$  nanoseconds  $\pm$  time base accuracy.  
**Time base input:** (HP 101A Oscillator recommended)  
 Frequency: 1 MHz.  
 Amplitude: 1 V rms into 1000 ohms.  
 Signal-to-noise ratio: 60 dB.  
 Phase and amplitude modulation: less than 0.1%.  
 Stability: compatible with measurement needs.  
**Registration:** 7 places, digital, in neon columns.  
**Reads in:** microseconds, with decimal point.  
**Start and stop trigger input:** separate channels.  
**Input impedance:** 50 ohms.  
**Minimum trigger pulse requirements:** 3 V peak, 0.5 V/nsec rise time, 5 nsec width.  
**Trigger polarity:** selectable, positive or negative.  
**Reset:** automatic, manual, or remote, using rear terminals.  
**Standard frequency counted:** 100 MHz.  
**Output:** 4-line BCD 1-2-2-4, "1" state positive; 4-line BCD 1-2-4-8, "1" state positive available as Option 02; "1"

state negative available on special order; "0" state:  $-8$  volts, "1" state:  $+18$  volts.  
**Impedance:** 100 k, each line.  
**Print command:** step from  $-6$  to  $+13$  volts, dc coupled, 2000-ohm source.  
**Hold-off requirements:** any voltage from 0 to  $+12$  volts, inclusive.  
**External reset:** connection to ground (0 V), 30  $\mu$ sec minimum duration.  
**Accessories furnished:** two 10503A Cables, 4 ft. long, male BNC connectors.  
**Operating temperature range:**  $-20^{\circ}\text{C}$  to  $+65^{\circ}\text{C}$ .  
**Dimensions:**  $16\frac{3}{4}$ " wide,  $3-15/32$ " high, 19" deep (425 x 88 x 483 mm).  
**Weight:** net, 15 lbs (7 kg); shipping 25 lbs (11 kg).  
**Price:** HP 5275A, \$2450.  
**Option 02:** 4-line BDC output, 1-2-4-8, "1" state positive in lieu of 1-2-2-4 (identical in all other respects), add \$10.  
**Option 03:** same as Option 02. except "1" state negative, add \$10.



## FREQUENCY METER

Wideband, highly linear FM Discriminator  
Model 5210 A/B

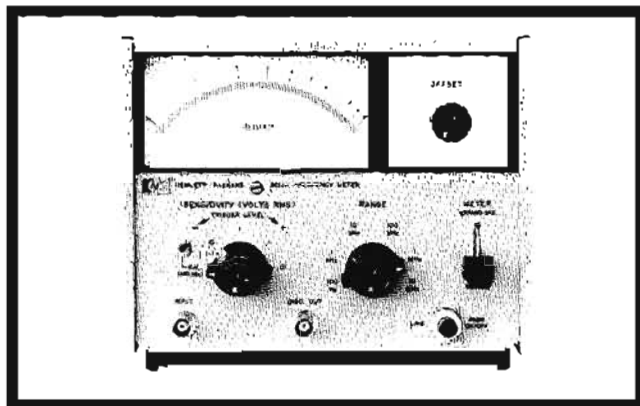

The Model 5210A Frequency Meter/FM Discriminator directly measures frequency or repetition rate of signals from 3 Hz to 10 MHz, independent of input voltage waveform. A sensitivity control allows for measurement of noisy signals. The special log linear scale offers an accuracy of 1% of reading from 10% of full scale up. With calibrated offset (Option 01) the effective accuracy is up to 0.2% of full scale range.

The 5210A is also a wideband highly linear FM Discriminator with a 3 dB output bandwidth of better than 1 MHz for precise measurements on FM and PM signals. With output filters (HP 10531A) frequency deviation, modulation index, frequency response, distortion, incidental FM, and FM noise can be determined as well as "flutter" and "wow" to better than 100 dB below carrier frequency.

The 5210B is particularly well suited for tachometry work with calibration directly in r/min.

### Specifications, 5210A

**Frequency range:** 3 Hz to 10 MHz in six decade ranges from 100 Hz full scale to 10 MHz full scale.

**Expanded scale:** with a continuously adjustable OFF-SET control, meter and recorder output display any 10% of full scale expanded to full scale.

**Sensitivity:** maximum sensitivity of 10 mV rms from 20 Hz to 10 MHz increasing to 200 mV at 3 Hz with four attenuator ranges of 0.01, 0.1, 1.0 and 10 V.

**Input impedance:** 1 M $\Omega$  shunted by 30 pF; used with HP 10001A 10:1 divider probe 10 M $\Omega$  shunted by 10 pF.

#### Accuracy:

**Discriminator output current:** 0.2% of reading below 1 MHz, 0.3% of reading on 10 MHz range.

**Meter:** 1% of reading from 10% of full scale to full scale.

**Expanded scale:** 0.1% of full scale for differential frequency readings.

**Calibration:** crystal calibration oscillator at 100 kHz accurate to  $\pm 0.01\%$ .

**Line voltage and frequency:** changes in line voltage of  $\pm 10\%$  and frequency of 50-1000 Hz cause less than 0.05% change in output.

**Temperature:** frequency reading changes less than 0.02%/°C 100 Hz to 1 MHz ranges, 0.04%/°C 10 MHz range from 0 to +55°C.

#### Recorder output:

**Level:** potentiometer outputs of 10 mV and 100 mV, adjustable from 9 mV to 11 mV and 90 mV to 110 mV for full scale; galvanometer output 1 mA into 2 k $\Omega$  max for full scale. Adjustable  $\pm 10\%$  for 1 k $\Omega$  to 2 k $\Omega$  loads.

**Linearity:** 0.025% of full scale 100 Hz to 100 kHz ranges;

0.05% of full scale 1 MHz range; 0.1% of full scale to 10 MHz range.

**Accuracy:** same as discriminator output current above.

**Time constant:** approximately 100 ms.

#### Discriminator output:

**Level:** adjustable 0.8 to 1.2 V for full scale.

**Linearity:** 0.025% of full scale 100 Hz to 100 kHz ranges. 0.05% of full scale 1 MHz range. 0.1% of full scale 10 MHz range.

**Bandwidth:** 3 dB down at greater than 1 MHz.

**Residual FM noise:** rms line frequency components below 300 Hz are 100 dB below the 1 V full scale output. At other frequencies the rms noise deviations are at least 120 dB below the carrier frequency when the noise is measured in a 6 Hz bandwidth.

**Power requirements:** 115 or 230 V ac  $\pm 10\%$  50-1000 Hz at less than 12 W.

**Dimensions:** 7-25/32" wide, 6-3/32" high and 11" deep; (190 x 155 x 279 mm).

**Weight:** net, 8 $\frac{3}{4}$  lbs (4 kg); shipping, 10 $\frac{1}{2}$  lbs (4.8 kg).

**Price:** HP 5210A \$575; Option 01 add \$125; HP 10531A \$175.

### Option 01, Calibrated Offset

**General:** the calibrated offset provides for display of any of the 10 major divisions on a separate full meter scale (the EXPAND scale). This allows frequency measurements to be made with higher accuracy than is possible using the meter in the NORMAL mode.

**Discriminator output:** same as above except bandwidth is 3 dB down at greater than 750 kHz.

**Accuracy:** 0.2% of full scale (range switch setting) for 100 Hz to 1 MHz ranges; 0.3% of full scale (range switch setting) for the 10 MHz range.

**Temperature:** the accuracy specification is increased by 0.01%/°C of reading on the 100 Hz to 1 MHz ranges and 0.03%/°C of reading on the 10 MHz range from 0°C to 55°C for deviations from 25°C when zero and self-calibration adjustments are made at the ambient temperature.

**Price:** add \$125 to price of 5210A/B.

### HP 10531A, Filter Kit

**General:** the HP 10531A Accessory Filter Kit provides a series of three plug-in low pass filters which can be adjusted to cover frequencies from 100 Hz to 1 MHz. These filters provide rejection of carrier and carrier harmonics while passing modulation components. Thus it is possible to measure demodulated signal components up to 20% of the carrier frequency using the HP 302A or 310A Wave Analyzers or similar narrow band voltmeters on their most sensitive ranges. By lowering filter cut-off frequency or in case of wide deviation signals measurements may be made using less selective voltmeters or other instruments.

**Frequency range:** the upper cut-off frequency can be adjusted from 100 Hz to 1 MHz. The lower cut-off frequency will vary up to 10 Hz, depending on load resistance used with the filter.

**Carrier rejection:** with the output filter the carrier and its harmonics are less than 30 mV rms total when the filter cut-off is less than 15% of the carrier frequency and drops to 1.0 mV maximum for filter cut-off frequencies less than 5% of the carrier frequency.

**Output impedance:** nominal 600  $\Omega$ . However, matched loads are not required.

**Output level:** zero to full scale deviations give 1 V open circuit at discriminator output.

**Price:** HP 10531A \$175.

### Specifications, 5210B

Model 5210B frequency meter is identical in construction and circuitry to 5210A but is calibrated in r/min for greater convenience in tachometry applications.

**Speed range:** 6000; 60,000; 600,000; 6,000,000 (CAL position) r/min.

**Maximum resolution:** 6 r/min.

**Price:** HP 5210B, \$570.



## METERS; TRANSDUCERS

Measure frequency, 3 Hz to 100 kHz  
Models 500B,C; 506A; 508A,B,C,D



## FREQUENCY



The HP Model 500B directly measures the frequency of an alternating voltage from 3 Hz to 100 kHz. Suitable for laboratory and production measurements of audio and ultrasonic frequencies, it also is useful for direct tachometry measurements with a transducer such as HP 506A or 508A,B,C,D.

Readings on the 500B and 500C are not affected by variations of input signal level or power line voltage. The meter will count sine waves, square waves or pulses and will indicate the average frequency of random events. Provision is made for checking the calibration against power line frequency and to operate a recorder for a continuous frequency record or x-y plot.

### Specifications, 500B

- Frequency range:** 3 Hz to 100 kHz, 9 ranges in 10, 30, 100 sequence.
- Expanded scale:** allows any 10% or 30% portion of a selected range to be expanded to full meter scale (except 10 Hz range).
- Input voltage:** sensitivity: 0.2 V rms minimum for sine waves, +1 V peak minimum for pulses; maximum, 250 V peak; sensitivity control reduces threshold sensitivity.
- Input impedance:** approx. 1 megohm shunted by 40 pF BNC connector for input.
- Accuracy:** better than  $\pm 2\%$  of full scale (unexpanded); reading affected less than 0.5% by  $\pm 10\%$  variation from nominal line voltage; expanded scale  $\pm 0.75\%$  of range switch setting.
- Output linearity:** (relation of input frequency to output current at the external meter jack): on 100 kHz range, within approx.  $\pm 0.25\%$  of full-scale value; other ranges,  $\pm 0.1\%$  of full-scale value.
- Recorder output:** 1 mA for full-scale deflection into 1400  $\pm$  100 ohms.
- Pulse output:** to trigger stroboscope, etc., in synchronism with input signal; to measure FM.

- Photocell input:** phone jack on panel provides bias for Type 1P41 Phototube; allows direct connection of 506A Tachometer Head.
- Power:** 115 or 230 volts  $\pm 10\%$ , 50 to 1000 Hz, 110 watts.
- Dimensions:** cabinet: 7 $\frac{1}{2}$ " wide, 11 $\frac{1}{2}$ " high, 14 $\frac{1}{2}$ " deep (191 x 292 x 368 mm); rack mount: 19" wide, 7" high, 13" deep (483 x 178 x 330 mm).
- Weight:** net 17 lbs (8 kg), shipping 19 lbs (9 kg) (cabinet); net 20 lbs (9 kg), shipping 30 lbs (14 kg) (rack mount).
- Accessory furnished:** 10501A Cable.
- Accessories available:** 506A Optical Tachometer, \$195; 508A, B,C,D Tachometer Generators, \$125 each; 500B-95A Accessory Meter for remote indication (operates from recorder jack), \$55.
- Price:** HP 500B, \$335 (cabinet); HP 500 BR, \$335 (rack mount)

### Specifications, 500C

- Model 500C Frequency Meter is identical in construction and circuitry to 500B but is calibrated in rpm for greater convenience in tachometry applications.
- Speed range:** 180 rpm (15 rpm with multiplying transducer) to 6,000,000 rpm, 9 ranges.
- Accessory available:** 500C-95A Accessory Meter, \$55.
- Price:** HP 500C, \$345 (cabinet); HP 500CR, \$345 (rack mount).

### 506A Optical Tachometer

Model 506A is a light source and photocell for use as a transducer with instruments such as HP 521 Series Electronic Counters, HP 500B Electronic Frequency Meter and HP 500C Electronic Tachometer Indicator.

### Specifications, 506A

- Range for direct reading:** 1 to 5000 rps with 521 Series; 3 to 5000 rps with 500B; 180 to 300,000 rpm with 500C; lower speed may be measured by using a multisegment reflector.
- Output voltage:** at least 1 V rms, 300 to 100,000 rpm (into 1 megohm or more impedance) with reflecting and absorbing surfaces  $\frac{3}{4}$ " square.
- Light source:** 21 candlepower, 6 volts automotive bulb.
- Phototube:** Type 1P41.
- Phototube bias:** +70 to +90 V dc (supplied by 500B,C 521).
- Power:** 115 or 230 volts  $\pm 10\%$ , 50 to 1000 Hz, 25 watts.
- Dimensions:** 22" high, 11" wide maximum (559 x 279 mm).
- Weight:** net 10 lbs (5 kg); shipping 17 lbs (8 kg).
- Accessories available:** 56A-16B Adapter Cable (connects 506A to 522B Counter), \$40.
- Price:** HP 506A, \$195.

### 508 Tachometer Generators

Models 508A,B,C,D Tachometer Generators are rotational speed transducers for use with electronic counters or frequency meters in making fast, accurate rpm measurements, 15 to 40,000 rpm. They are specifically designed to operate with Hewlett-Packard electronic counters and frequency meters.

### Specifications, 508 Series

- Shaft speed range:** 508A, 15 to 40,000 rpm; 508B, 30 to 30,000 rpm; 508C, 40 to 25,000 rpm; 508D, 50 to 5000 rpm.
- Output frequency:** 508A, 60 cycles/rev.; 508B, 100 cycles/rev.; 508C, 120 cycles/rev; 508D, 360 cycles/rev.
- Drive shaft:**  $\frac{1}{4}$ " diameter, projects 19/32".
- Running torque:** approx. 0.15 in-oz; 0.5 in-oz at 1500 rpm.
- Peak starting torque:** approximately 4 in-oz.
- Dimensions:** 2-7/16" high, 3 $\frac{1}{2}$ " wide, 3 $\frac{3}{4}$ " deep (62 x 89 x 95 mm).
- Weight:** net 2 lbs (1 kg); shipping 3 lbs (1 kg).
- Price:** HP 508A,B,C,D, \$125 each.



## FREQUENCY METERS

For general-purpose or lab use  
Models 532A, 536A, 537A

### Advantages

- High resolution, easy-to-read dial
- Direct reading
- Broadband
- Accuracy specified over 20°C and 0 to 100% relative humidity

These direct-reading frequency meters allow you to measure frequencies from 3.95 to 40 GHz in waveguide and from 960 MHz to 12.4 GHz in coax quickly and accurately. Their long scale length and numerous calibration marks provide a high resolution which is particularly useful when measuring frequency differences or small frequency changes. Frequency is read directly in GHz so no interpolation or charts are required.

The instruments comprise a special transmission section with a high-Q resonant cavity which is tuned by a choke plunger. A 1 dB or greater dip in output indicates resonance; virtually full power is transmitted off resonance. Tuning is by a precision lead screw, spring-loaded to eliminate backlash. Resolution is enhanced by a long, spiral scale calibrated in small frequency increments. For example, Model X532B has an effective scale length of 77 inches (1956 mm) and is calibrated in 5-MHz increments. Resettability is extremely good, and all frequency calibrations are visible so you can tell at a glance the specific portion of the band you are measuring. Except for the J532A, there are no spurious modes or resonances. (See note 4 below.)

### Specifications, 532A,B, 536A and 537A

HP Model	Frequency range (GHz)	Dial accuracy (%)	Overall accuracy <sup>1</sup> (%)	Calibration increment (MHz)	Price
536A	0.96-4.20	0.10 <sup>2</sup>	0.17 <sup>3</sup>	2	\$500
537A	3.7-12.4	0.10	0.17	10	\$500
G532A	3.95-5.85	0.033	0.065	1	\$400
J532A	5.30-8.20 <sup>4</sup>	0.033	0.065	2	\$375
H532A	7.05-10.0	0.040	0.075	2	\$325
X532B	8.20-12.4	0.050	0.08	5	\$200
M532A	10.0-15.0	0.053	0.085	5	\$350
P532A	12.4-18.0	0.068	0.10	5	\$275
K532A <sup>5</sup>	18.0-26.5	0.077	0.11	10	\$350
R532A <sup>5</sup>	26.5-40.0	0.083	0.12	10	\$400

<sup>1</sup> Includes allowance for 0 to 100% relative humidity, temperature variation from 13 to 33°C, and backlash.

<sup>2</sup> 0.15, 0.96 to 1 GHz.

<sup>3</sup> 0.22, 0.96 to 1 GHz.

<sup>4</sup> Because of the wide frequency range of the J532A, frequencies from 7.6 to 8.2 GHz can excite the TE<sub>112</sub> mode when the dial is set between 5.3 and 5.6 GHz.

<sup>5</sup> Circular flange adapters: K-band (UG-425/U) 11515A, \$35 each; R-band (UG-381/U) 11516A, \$40 each.

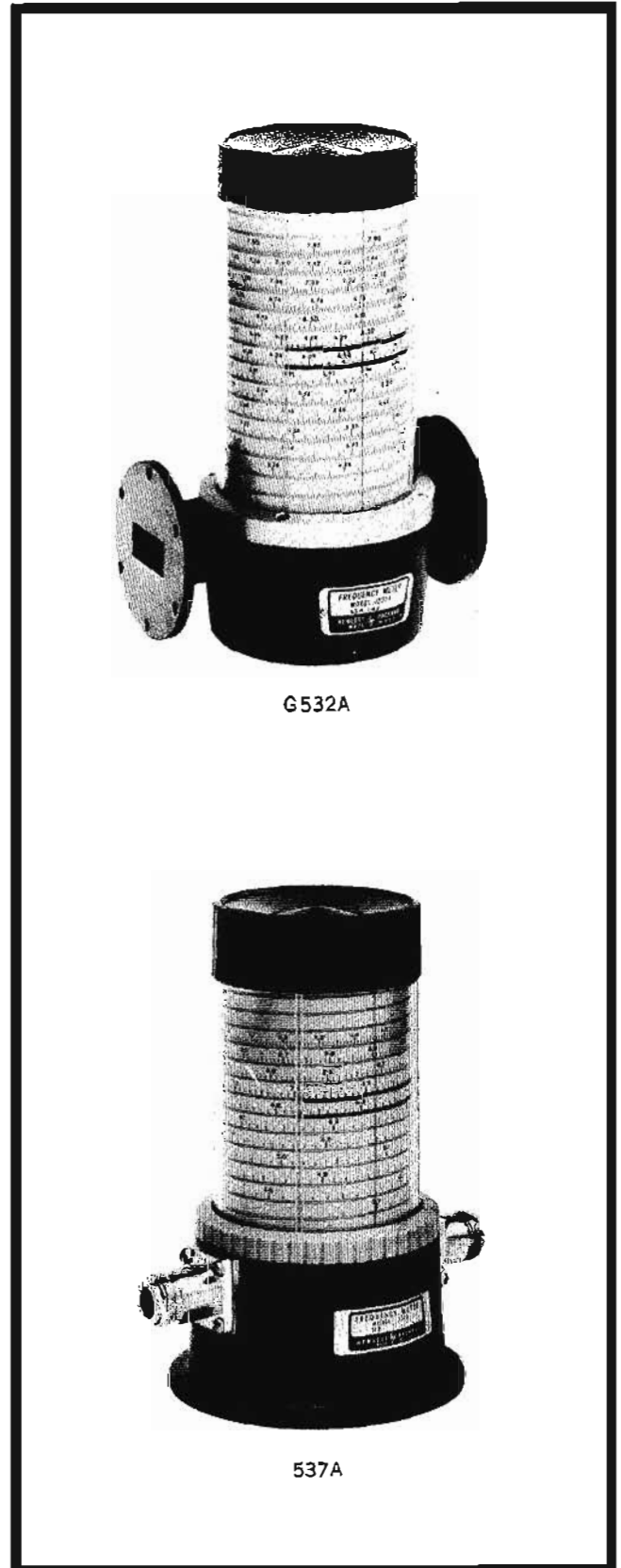

G532A

537A



Hewlett-Packard offers frequency, time standard systems which provide accurate frequencies, time intervals. Further, Hewlett-Packard systems provide means for comparing these important quantities against national standards such as the U. S. Frequency Standard (USFS). Units of frequency, time cannot be kept in a vault for ready reference. They must be generated for each use, hence must be regularly compared against recognized primary standards.

Frequency, time standard systems manufactured by Hewlett-Packard are used for control and calibration at astronomical observatories, national centers for measurement standards, physical research laboratories, missile and satellite tracking stations, manufacturing plants and radio monitoring and transmitting stations. System applications include the following: distributed standard frequencies in factories or research facilities ("house standards"), control of standard frequency, time standard broadcasts, synchronization of electronic systems for navigation, investigation of radio propagation phenomena, frequency synthesis, control, and adjustment of single side-band communications equipment.

Four performance characteristics are of vital interest to users of frequency, time measurement equipment and standards: accuracy, precision, stability, and reliability. Hewlett-Packard systems offer these four in ample measure, plus one more: operational simplicity. Hewlett-Packard has devoted the efforts of an entire division to the continual improvement and innovation necessary to keep in the forefront of frequency, time measurements and standards.

### Cesium beam frequency standard

Cesium beam standards are in use wherever the goal is highest accuracy, in fact, the U. S. Frequency Standard itself is of the cesium beam type. The cesium beam standard is an atomic resonance device which provides access to one of nature's invariant frequencies in accordance with the relationships of quantum mechanics. The cesium standard is a *true primary standard* and requires no other reference for calibration.

Atomic frequency standards are based on the frequency  $\nu$  corresponding to a transition between two atomic states separated in energy by  $\Delta E$ :

$$\Delta E = h\nu$$

where  $h$  is Planck's Constant. Common to atomic standards are means for (1)

selecting atoms in a certain energy state, (2) enabling long lifetimes in that state, (3) exposing these atoms to (microwave) energy, and (4) detecting the results.

For the cesium beam standard, the quantum effects of interest arise in the nuclear magnetic hyperfine ground state of the atoms. The transition described as ( $F=4, m_F=0$ )  $\leftrightarrow$  ( $F=3, m_F=0$ ) is observed.

The HP Model 5060A is a portable cesium beam standard proved capable of realizing the cesium transition frequency to the same levels of accuracy and long-term stability usually achieved by large-scale laboratory models.

The 5060A operates to keep an ultra stable quartz oscillator precisely "on frequency" via servo-control that refers, ultimately, to the center of the atomic resonance. The output signal is derived from the quartz oscillator, the cesium beam tube serves as its reference — and the two are linked by circuitry that includes means to adjust the frequency of the quartz oscillator to automatically compensate for its aging or drift.

A simplified sketch of the beam tube is shown in Figure 1.

It is possible to accelerate cesium atoms by a force dependent on the applied magnetic field gradient together

other; and those which have made the transition in the desired direction are selected and directed by a second field ("B" magnet) onto a detector.

Now, the maximum signal means that the maximum number of transitions are occurring, which indicates that the injected microwave energy is of precisely the transition frequency. The oscillator which is the source of this energy is therefore known to be operating at a frequency directly related to the transition frequency. A constant of the atom has been made the frequency reference.

### Quartz crystal oscillators

The modern era of precision frequency control was initiated in the 1920's when the quartz crystal resonator was first applied in the construction of frequency, time standards. Its use in instruments for the generation and measurement of precision frequencies is now universal in national and industrial laboratories of the world. Today, the most exacting uses demand atomic resonance control. Nonetheless, quartz crystal oscillators remain the workhorses of virtually every frequency control application.

In use to control an oscillator, a quartz resonator is mounted between conducting electrodes, usually thin metallic (gold) coatings deposited directly on the crystal

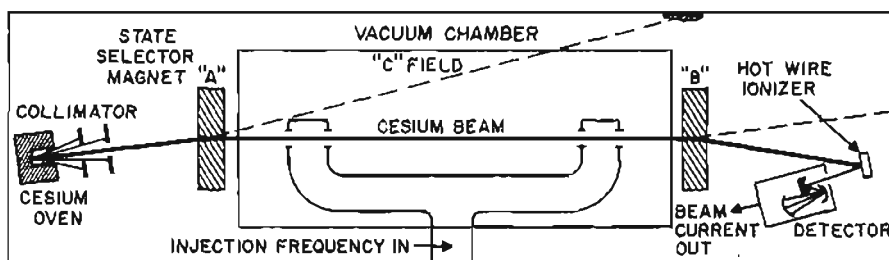

Figure 1. Schematic of cesium beam resonator.

with the atom's magnetic dipole moment. Thus cesium atoms can be sorted and focused by passing a beam of them through a magnetic field having a high gradient ("A" magnet). Atoms in the quantum state of interest are directed down the beam tube and others are deflected away. These selected atoms then drift through a space where the field ("C" field) is kept low (typically, about 50 milligauss) and uniform and are subjected to microwave radiation corresponding to just the frequency which separates the two energy levels. The atoms flop from one energy state to the

by evaporation. Mechanical support is provided at places on the crystal chosen to avoid any inhibition of the desired vibration and if possible such that unwanted vibration modes are suppressed. Advantage is taken of the piezoelectric effect that links mechanical vibrations and electrical effects in certain crystals. An alternating voltage applied across a properly cut quartz crystal causes it to vibrate at a selected natural frequency. This crystal resonator behaves as though it were an electrical network and can be made to impose its own frequency upon an oscillator circuit.

An inherent characteristic of crystal oscillators is that their resonant frequency changes (usually increases) as they age. This "aging rate" or "drift" of a well-behaved oscillator is almost constant. After the initial aging period (a few days to a month) the rate can be taken to be constant with but slight error. Once the rate is measured, it is usually easy to correct data to remove its effect. Over a long period, the accumulated error drift could amount to a serious error. Thus, periodic frequency checks are needed to maintain a quartz crystal frequency standard. (The cesium beam standard, on the other hand, has no known drift.)

Hewlett-Packard offers the Model 106A/B Quartz Oscillator, rated at 5 parts in  $10^{11}$  per day long-term stability, and the ruggedized HP Model 107AR/BR, rated at  $5 \times 10^{10}$  per day. Such exceptional stability (and, substantially better performance is attained under normal operating conditions) results from careful attention to all controllable factors such as selection of the highest quality crystals, their operation in precision temperature controlled ovens, and their incorporation into inherently stable circuits designed for low power dissipation within the crystal.

### Spectral purity

A frequency standard must provide a stable, spectrally pure signal if it is to yield a narrow spectrum after multiplication to the microwave region. Even a crude oscillator will have a reasonably good spectrum at the frequency of oscillation. The spectrum rapidly degrades with frequency multiplication, however.

Hewlett-Packard quartz oscillators are designed to produce just such a signal; the HP 106A/B gives spectra only slightly degraded even after high multiplication.

Figure 2 shows a noise spectrum plot for the HP 106A/B Quartz Oscillator (see HP Application Note 52, "Frequency, Time Standards", page 5-3 for details of this noise measurement).

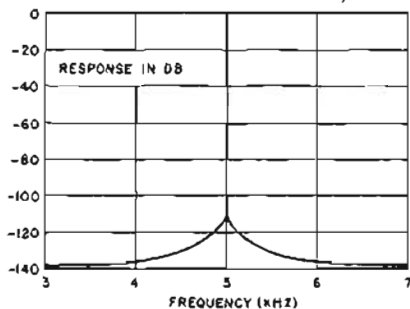

Figure 2. Spectrum of a 5 kHz beat note at 9.2 GHz; comparison of two HP 106A/B Oscillators.

### Frequency standards and clocks

Time standards and frequency standards have no fundamental differences — they are based upon dual aspects of

the same phenomenon. The reciprocal of time interval is frequency. Frequency measurements are measurements of the number of cycles — counted one by one — per time interval (second). For precision oscillators, a complete statement of frequency must include the time scale in use, so that the exact length of the time interval is specified.

As a practical matter, to maintain a time standard places stringent additional requirements upon a frequency standard. A clock is a device for counting cycles. The time it keeps is a function of its driving frequency: in effect, a clock integrates frequency. Even a small frequency error can cause large time errors to accumulate, for a clock must measure off nearly 100,000 seconds in just one day.

The basis for a modern time standard clock is an ultra-stable oscillator, often a quartz crystal oscillator. The low frequency convenient for clock operation must be derived from the high quartz frequency (typically, 0.1 MHz to 5 MHz) in a way that does not degrade its accuracy. This is accomplished by fail-safe regenerative dividers. A local time standard, then, comprises (1) a stable, precision oscillator and (2) a frequency divider and clock.

A cesium beam standard is the ideal frequency standard to drive a clock because of its unsurpassed long-term stability. If a quartz oscillator or other secondary standard is used, it must be evaluated for rate of drift and be kept carefully corrected.

Most clocks are desired to keep time in synchronism with a system master clock. Where time of day is concerned, this master clock for the United States is one which is operated at the U. S. Naval Observatory. For accurate time keeping, the local system must (1) provide a consistent time interval, (2) be initially "set" against master time, and (3) be checked periodically to insure that the two time scales keep together.

Easy comparison to master time is built into the HP 115BR/CR. Overall time comparison accuracy of  $\pm 10$  microseconds is possible by use of the time reference control, a directly calibrated precision resolver.

### Frequency comparison by VLF broadcast

One excellent way to keep a local system's frequency — hence, time interval — referenced against master time interval is by use of a low frequency standard broadcast such as the National Bureau of Standards WWVB, 60 kHz. Prime means for doing this with ease and convenience is the HP 117A Comparator. This unit is a complete system in itself. The strip chart produced by the 117A records minute by minute the results of

a precision phase comparison (resolution, 1  $\mu$ sec) of the local signal against the received signal to show frequency offset or error of the local standard, and over a few hours to a day or more, its drift rate.

### Reliable, fail-safe operation

Hewlett-Packard frequency, time standards have many features that ease maintenance of house frequency standards and timekeeping systems to high accuracies. First of all, Hewlett-Packard standards have built-in dependability. For example, regenerative dividers of the non-self-starting type are used in the 115BR/CR frequency divider and clock; the very presence of an output signal is a positive indication that divider output has not lost time relative to the driving signal. The dividers stop and remain stopped upon any interruption of signal or of supply power.

The HP 106A/B and 107AR/BR quartz oscillators have a digital indicator, calibrated in parts in  $10^{11}$  ( $10^{10}$  for 107AR/BR), which greatly facilitates making fine corrections to bring the oscillator back to reference frequency, as determined by offset measurements made against NBS via the 117A Comparator.

### Standby power supplies

Minimum down-time, important for any system, is vital to a time standard. Its worth depends directly on continuity of operation. Non-interrupted operation is also important to ultra-precise quartz oscillators. If a crystal is allowed to cool from its operating temperature, upon renewed operation it may assume a frequency offset and even an altered aging rate.

Hewlett-Packard standby power supplies ensure continued operation despite line interruptions, and operate over a range of ac line voltage to supply regulated dc to operate quartz oscillators and frequency dividers and clocks. The batteries in the supplies assume the full load immediately when ac power fails.

Alarm systems include local indication of operating conditions and provisions for remote alarms.

### Variable frequency source

There is application in many areas such as microwave spectroscopy and production testing of frequency sensitive devices for an instrument having the basic stability and spectral purity of a precision quartz oscillator, yet offering not just a few frequencies but 5 billion discrete frequencies. This, over a frequency range of 0.01 Hz to 50 MHz, is the capability of the 5100A/5110A Frequency Synthesizer; the 5105A/5110B provides 0.1 MHz to 500 MHz. Other synthesizers cover various frequency ranges.

## Atomic and UT-2 time scales

The time interval of the atomic time scale is the International Second, defined in October 1964 by the Twelfth General Conference of Weights and Measures:

"The standard to be employed is the transition between two hyperfine levels  $F=4, m_F=0$  and  $F=3, m_F=0$  of the fundamental state  $^2S_{1/2}$  of the atom of cesium-133 undisturbed by external fields and the value  $9\,192\,631\,770$  hertz is assigned."

The Universal Time Scale,  $UT_2$ , is related to the earth's rotation and has been proceeding at a rate slightly slower than that of the atomic scale. Its time interval — second — is slightly longer.

U. S. Standard Time, kept by the U. S. Naval Observatory's master clock, differs from nominal  $UT_2$  by an integral number of hours. The time interval broadcast by NBS stations WWV, WWVH, and WWVL is that of a smoothed approximation to  $UT_2$ . WWVB (60 kHz) broadcasts the atomic second, without offset.

A time scale which approximates  $UT_2$  can be produced by oscillations offset from the atomic frequency in an amount proportional to the difference in the intervals employed. By international agreement, the amount of this frequency offset is fixed each year by the Bureau International de l'Heure, in Paris: for 1966 it is  $-300 \times 10^{-10}$ .

Operational complications which arise owing to the need for changed offsets from year to year are eased considerably by design provisions Hewlett-Packard makes. For example, the HP 5060A is adjustable to a changed offset simply by the interchange of an inexpensive quartz crystal, and retuning. The HP 117A Comparator is adjustable simply by a gear ratio change in the translator kit.

Hewlett-Packard systems anticipate future needs as well. Should the user desire, he easily can convert his Hewlett-Packard system from  $UT_2$  to the atomic scale, or vice-versa.

## Timekeeping to microsecond accuracy

Studies and systems requiring synchronized measurements at points widely separated in distance increasingly demand time standards capable of microsecond accuracy. Examples are studies of the propagation of electromagnetic waves and of advanced systems for navigation and for aircraft collision avoidance.

In the 1966 Flying Clock Experiment,\* Hewlett-Packard demonstrated a system of three cesium beam time standards, one stationary and two transported by commercial airlines and automobiles on a

\*Hewlett-Packard Journal 17, 12 August 1966

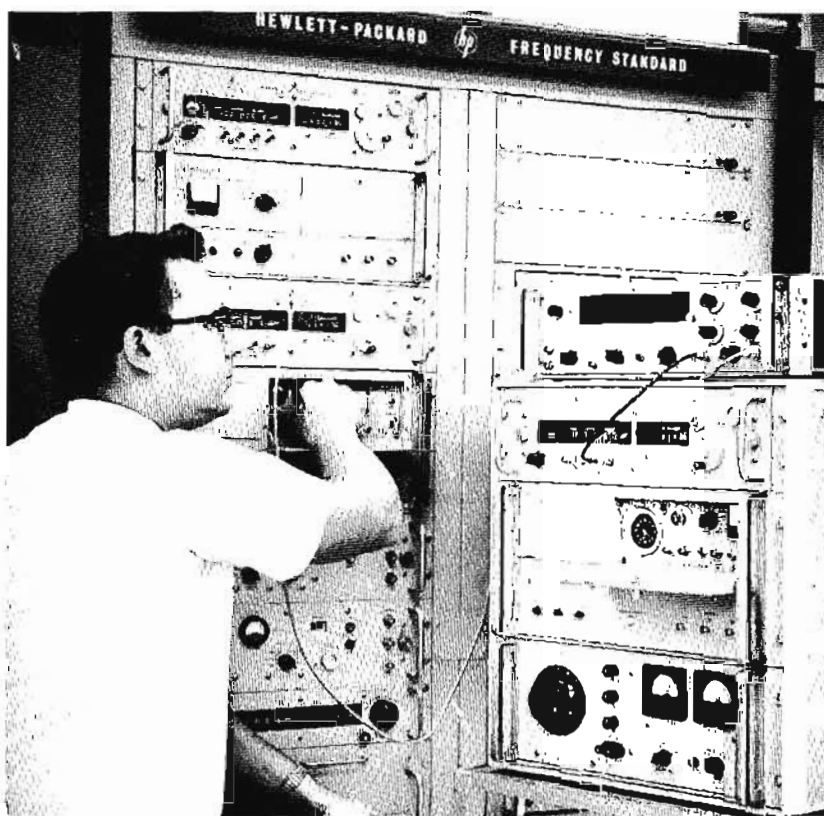

Figure 3. One of the HP "Flying Clocks" being compared against the HP House Standard by use of an HP 5245L Electronic Counter (on top of the clock).

50,000 mile journey, that maintained time over an entire month to a mutual agreement within one microsecond.

This is believed to be the first time that clocks operated independently of each other for a month — no frequency adjustments or time resets were made during the trip — have maintained time to such a close agreement.

Older methods relying on high frequency radio signals cannot correlate widely separated clocks to much better than a millisecond. The use of a portable time standard that travels among all the clocks of a system to correlate them with system master clock has proved to be an ideal means to establish time to microsecond accuracy.

Hewlett-Packard offers a portable time standard, the E20-5060A, which has proved itself capable of microsecond accuracy and which is easily transported by commercial airlines and automobiles.

## Hewlett-Packard time and frequency standard

The HP House Standard has as its basic reference the HP 5060A Cesium Beam Standard. Output is kept continually compared in phase with the U. S. Frequency Standard (USFS) at Boulder, Colorado by reception of NBS standards

stations WWVB and WWVL via HP 117A Comparators. The standard is also compared to two of the U. S. Navy's VLF stations. Time is correlated on each occasion when the HP Flying Clocks visit U. S. national timekeeping centers. Frequency is maintained in agreement with USFS to an accuracy within parts in  $10^{10}$ . Studies have shown this standard to rank among the world's most accurate.

The output of the house working frequency standard, an HP 107AR Quartz Oscillator, is distributed throughout the Hewlett-Packard plant in Palo Alto, wherever precision frequency, time instrumentation is being built and tested.

Figure 3 shows one of the HP Flying Clocks being compared against the HP House Standard just before its round-the-world trip. A precision time comparison is being made by use of the HP 5245L Electronic Counter with a time interval plug-in.

The measurement is one of totalizing pulses during the interval separating the one-second ticks generated by the flying clock and those generated by the reference clock.

Hewlett-Packard Application Note 52, "Frequency, Time Standards", discusses practical aspects of equipment, operation, and time scales (100 pages).

**CESIUM BEAM FREQUENCY STANDARD**

 Compact primary standard,  $\pm 1 \times 10^{-11}$  accuracy

Model 5060A

**Advantages:**

- Accuracy of  $\pm 1$  part in  $10^{11}$
- Circuit-check meters and lights monitor operation
- All solid-state circuits, low power consumption
- Compact—8¾ inches high, 63 pounds

The Hewlett-Packard Model 5060A is a compact, self-contained primary standard of the atomic beam type, utilizing Cesium 133. A new cesium beam tube resonator stabilizes the output frequency of a high quality quartz oscillator. Solid-state modular design is used throughout, and the closed-loop, self-checking control circuit yields exceptional accuracy of  $\pm 1 \times 10^{-11}$ .

The cesium beam tubes exhibit frequency perturbations so small that independently constructed tubes compare within a few parts in  $10^{12}$ . Outstandingly reliable, these tubes have a guaranteed life of 10,000 hours. Either atomic or UT-2 time scale can be supplied on order. A simple change of one component is all that is required for field conversion of the time scale, or for UT-2 offset corrections.

The quartz crystal oscillator used in the 5060A has superior characteristics even without control by the atomic resonator. The quartz oscillator portion of this cesium beam standard is identical to the HP 107AR. Drift rate is less than  $5 \times 10^{-10}$  per 24 hours, and short term stability is better than  $\pm 1.5 \times 10^{-11}$  for a one-second averaging time.

The 5060A is compact and portable, no complex permanent installation is required. The 5060A has achieved outstanding reliability in field service.

**Operation**

In the atomic resonator a beam of state selected Cesium 133 atoms passes through a microwave cavity. When the

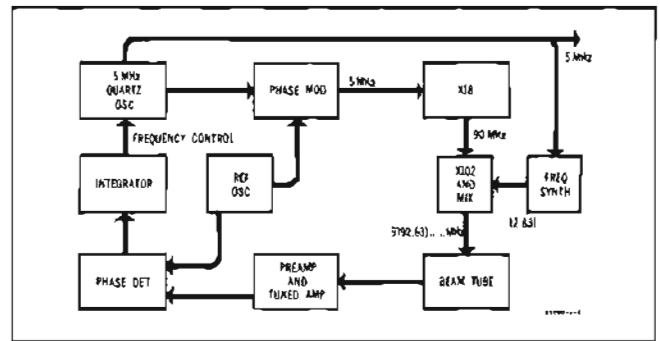

Figure 1

frequency of the microwave magnetic field is near the hyperfine transition frequency of Cesium 133, it induces transitions from one energy level to another. Those atoms which have undergone such a transition are then detected by a hot wire ionizer and electron multiplier. The microwave field, derived from a precision quartz oscillator by frequency multiplication and synthesis, is phase modulated at a low audio rate. When the microwave frequency deviates from the center of the atomic resonance, the current from the electron multiplier contains a component alternating at the modulation rate and proportional to the frequency deviation. This component is then filtered, amplified, and synchronously detected to provide a dc voltage proportional to the frequency deviation. The integral of this dc voltage is then used to automatically tune the quartz oscillator to zero frequency error.

The control circuit provides continuous monitoring of the output signal. Automatic logic circuitry is arranged to present an indication of correct operation. Figure 1 shows a simplified block diagram of the 5060A operation.





## Specifications

**Accuracy:**\*  $\pm 1 \times 10^{-11}$ .

**Reproducibility:**\*  $\pm 5 \times 10^{-12}$ .

**Long term stability:**\*  $\pm 1 \times 10^{-11}$ .

**Short term stability:** rear panel switch selects 1 sec or 60 sec loop time constant.

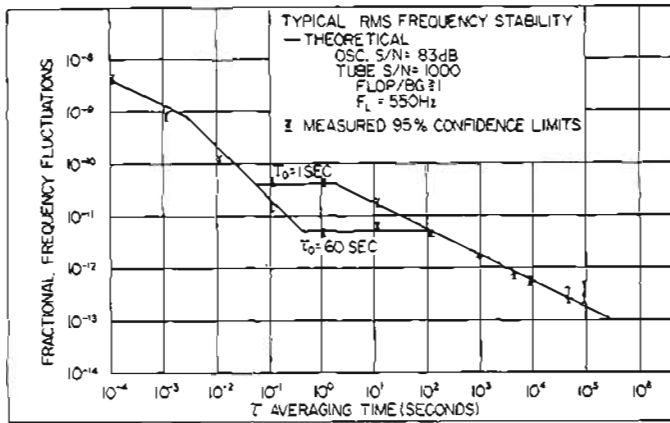

**Warm-up time:** 1/2 hour (time to reach specified accuracy with oscillator at operating temperature), 4 hours (from cold start).

**Signal to noise ratio:** for 1 and 5 MHz, >83 dB at rated output (in a 30 kHz noise bandwidth; 5 MHz output filter bandwidth is approx. 125 Hz). For 100 kHz, >60 dB in 30 kHz noise bandwidth.

**Harmonic distortion:** (5 MHz, 1 MHz, and 100 kHz) down more than 40 dB from rated output.

**Non-harmonically related output:** (5 MHz, 1 MHz, and 100 kHz) down more than 80 dB from rated output.

**Output frequencies:** 5 MHz, 1 MHz, 100 kHz sinusoidal, 100 kHz clock drive.

**Output voltages:** 1 V rms into 50 ohms; clock drive suitable for Hewlett-Packard Frequency Divider and Clocks.

**Output terminals:** 5 MHz, 1 MHz, 100 kHz, front and rear BNC connectors, 100 kHz clock drive, rear BNC connector.

**Time scale:** atomic or  $UT_2$  supplied to order. Simple change of one component enables field conversion of time scale or adjustment of  $UT_2$  offset changes.

### Cesium beam tube

**Length:**  $16 \pm 1/16$ ".

**Diameter:** approx.  $5\frac{3}{8}$ ".

**Weight:** 16 lbs.

**Line width:** 550 Hz ( $\pm 20\%$ ).

**S/N ratio (voltage):** typical, 1000 ( $\frac{1}{4}$  Hz noise bandwidth).

**RF power (9192 MHz):** 30 microwatts.

**Power input, 25°C, typical:** 6.5 watts.

**Life:** 10,000 hours guaranteed (operating), within 2 years of receipt of tube.

### Quartz oscillator only

(with cesium beam tube switched off)

**Aging rate:**  $\pm 5$  parts in  $10^{10}$  per 24 hrs. after 21 days continuous operation.

**Stability:** as a function of ambient temperature,  $< \pm 1 \times 10^{-10}$  from 0° to +50°C; of load,  $< \pm 1 \times 10^{-11}$  for open circuit

to short and 50 ohms R, L, C load change; of supply voltage,  $< \pm 1 \times 10^{-11}$  for 22 to 30 V dc, or for 115/230 V ac,  $\pm 10\%$ .

**RMS deviation of 5 MHz output** (due to noise and frequency fluctuations):

Average time	Max RMS fractional-frequency deviation ( $\Delta f/f$ )	Max RMS phase deviation (milliradians)
1 msec	$8 \times 10^{-10}$	0.03
10 msec	$1.5 \times 10^{-10}$	0.04
0.1 sec	$1.5 \times 10^{-11}$	0.04
1 sec	$1.5 \times 10^{-11}$	0.4
10 sec	$1.5 \times 10^{-11}$	4.0

All data based on at least 100 samples. Data taken over a 20-sec interval for 1 msec, 10 msec, and 0.1 sec averaging times, over 200- and 2,000-sec intervals respectively, for 1 and 10 sec averaging times. Crystal aging rate has been removed.

**Frequency adjustments:** fine: 5 parts in  $10^6$  total; 1 part in  $10^9$  per rev.; 1 part in  $10^{10}$  per div at 10 div per rev. Coarse:  $5 \times 10^{-7}$  ( $\pm 2.5 \times 10^{-7}$ ). Coarse and fine controls are screw-driver adjustments.

## General specifications

**Environmental:** typical stability with respect to temperature is  $< \pm 5 \times 10^{-12}$ , 0 to 50°C. Humidity, 0 to 95%. Typical stability with respect to magnetic fields is  $< \pm 1 \times 10^{-11}$ , 2 gauss field, any orientation. Production 5060A's have passed the stringent shake and vibration test MIL-STD-167, and have exceeded the electromagnetic compatibility specification, MIL-I-6181D (EMC, also known as RFI).

**Power:** 115 or 230 V ac  $\pm 10\%$ , 50 to 1000 Hz or 22 to 30 V dc. Approximately 50 watts operating.

**Dimensions:**  $16\frac{3}{4}$ " wide x  $16\frac{3}{8}$ " deep x  $8\frac{3}{4}$ " high (425 x 416 x 221 mm).

**Weight:** net 63 lbs (28.6 kg); shipping 105 lbs (47.8 kg).

**Accessories furnished:** Rack Mounting Kit 5060-0777, Plug-in Board Kit 05060-6117 (extenders and plugs), detachable 6-ft. ac Power Cord, connectors 1251-0038 (Cannon MS-3106A10SL-35C) and 1251-0037 (A.P.M. Corp.) UP1 131M (NUP 121M).

**Accessories available:** 10520A Time Scale Crystal Accessory Kit, \$300. Set of 8 crystals for the atomic or  $UT_2$  interval, and  $UT_2$  offsets ( $-50$  to  $-400$ )  $\times 10^{10}$ . Holder to mount inside instrument. Single crystal to convert Option 01 to 02 or vice versa, \$40 each.

**Time scales:** one must be specified (no cost). Option 01, Atomic time scale; Option 02,  $UT_2$  time scale.

**Price:** Model 5060A, \$15,500.

### DEFINITION OF TERMS

**Accuracy:** The degree to which oscillator frequency is the same as that of an accepted primary standard (for example, the U.S. Frequency Standard), or the degree to which oscillator frequency corresponds to the accepted definition, presently that of the 12th General Conference of Weights and Measures.

**Reproducibility:** The degree to which an oscillator will produce the same frequency from unit to unit and from one occasion of operation to another. Included within this definition is the degree to which the frequency of an oscillator can be set by a calibration procedure.

**Long Term Stability:** Total fractional frequency drift for the life of the cesium beam tube.





## CESIUM BEAM TIME STANDARD

Time from portable primary standard  
Model E20-5060A

### Advantages:

- ±1 × 10<sup>-11</sup> Accuracy
- Stabilized time ticks
- Easily converted time scale
- Versatile power supply with standby reserve
- Portable

The Hewlett-Packard Model E20-5060A Portable Cesium Beam Time Standard is a rugged, accurate, and versatile system that will transport time and frequency. It consists of an HP 5060A Cesium Beam Frequency Standard, an HP H20-115BR Frequency Divider and Clock and an HP K02-5060A Power Supply all enclosed in a cabinet with carrying handles.

The Hewlett-Packard Model 5060A is a compact, self-contained primary standard of the atomic beam type, utilizing cesium 133. The closed-loop, self-checking control circuit combined with the atomic resonator and a high quality quartz oscillator yield exceptional accuracy of ±1 × 10<sup>-11</sup>. The 100 kHz output frequency is translated to a 1 pps time tick by the H20-115BR.

The HP H20-115BR Frequency Divider and Clock uses fail-safe regenerative dividers and a gate circuit to provide an essentially jitter-free 1 pps time tick for accurate time comparison. The tick may be positioned in time by means of a self-contained phase shifter which is calibrated in 1 μsec increments. Time is indicated in hours, minutes, and seconds by an in-line digital readout for ease in reading and setting the clock.

The K02-5060A Power Supply is a special unit designed expressly for use in the portable time standard. This versatile power supply makes it possible to power the time standard from commercial aircraft and auto electrical systems, various storage batteries, commercial power lines, or its own internal nickel-cadmium batteries.

Similar "Flying Clocks" were used by Hewlett-Packard in a time correlation experiment performed in the summer of 1966.\* In this experiment, two clocks were flown to major timekeeping centers in the United States, Western Europe, and Japan. The traveling clocks were set to agree in frequency with the HP House Standard before their departure. Time closures a month later at the conclusion of the 50,000-mile journey showed the three time standards — each one based on a 5060A — to have kept within a relative error of less than one microsecond. This corresponds to a frequency offset of a few parts in 10<sup>17</sup> over the entire month.

\*Hewlett-Packard Journal 17, 12 (August 1966).

### Specifications

**Accuracy:** ±1 × 10<sup>-11</sup>.

**Stability, long term:** ±1 × 10<sup>-11</sup>.\*

**Outputs:** 5 MHz, 1 MHz, 100 kHz, 1 V rms into 50Ω (5060A), 100 kHz, 10 kHz, 1 kHz, 0.25 V rms from 1200Ω source impedance (H20-115BR).

**Time tick:** 1 pps, —15 V pulse into 1 kΩ, rise time <0.5 μsec, width >10 μsec, jitter <0.05 μsec. Temperature stability, 0.02 μsec/°C (H20-115BR).

**Effects of transients:** will not gain or lose time due to:

1. ±300 volt step function on 100 kHz input to H20-115BR.
2. 0 to 50 volt pulses, 0 to 500 pps, 1 to 10 μsec duration on 100 kHz input to H20-115BR.
3. ±4 volt step in 26 V dc input.

**Operating temperature:** 0 to +50°C.

**Magnetic field:** 0 to 2 gauss.

**Power:** 6 or 12 V dc ±10% ±20%; or 24 to 30 V dc; or 115 ±15 V ac, or 230 ±30 V ac, 50-400 Hz, 60 watts, batteries not charging; 108 watts maximum.

**Standby capacity:** 8 hours at 25°C.

**Recharging:** approximately 2.5 hours recharging time at maximum rate for each hour of standby operation.

#### Accessories provided:

- Cable: AC input, HP 05060-91026.
- Cable: AC output, power supply to 5060A, HP 05060-91028.
- Cable: DC output, power supply to 5060A, 103A-16A.
- Cable: DC output, 5060A to H20-115BR, 113A-16E.
- Cable: Coax, BNC to BNC, 5060A to 115BR, HP 10503A.
- Cable: DC input, HP 05060-91027.
- Plug-in Board Kit, 05060-6117.
- AC Power Cable: 5060A to standard wall outlet, 114B-16A.

\*Total fractional frequency drift for the life of the cesium beam tube

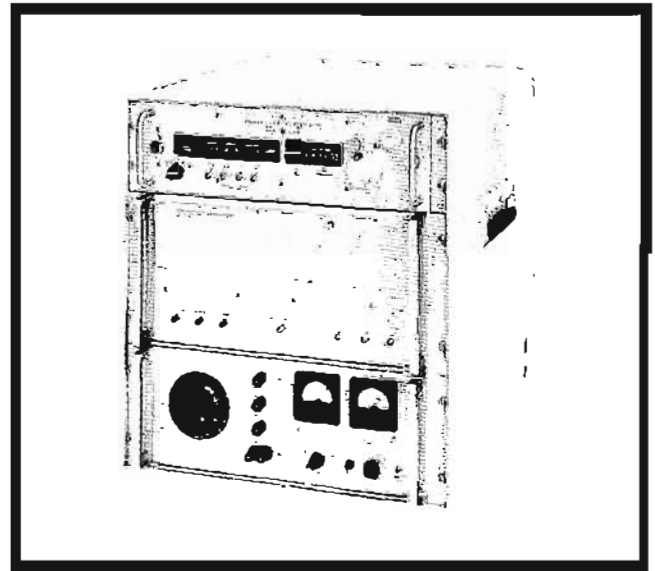

**Dimensions:** 19-13/16" wide x 21-13/16" high x 21-11/16" deep (503 x 554 x 550 mm).

**Weight:** net, 215 lbs.

**Price:** \$21,600.

### K02-5060A Power Supply

**Output voltages:** 0 to 280 V rms ac variable, 50 to 400 Hz, 26 ±4 V dc.

**Output current:**

AC: 1.5 amp maximum.

DC: 2.5 amp per battery, 10 amp maximum.

**Standby capacity:** 12 amp hours at 25°C, 8 hours standby time at 25°C when used in E20-5060A.

**Recharging:** 1.6 hours required for each amp hour discharge. Each of four batteries have independent charging circuits for increased over-all reliability.

**Alarm indicator:** ac on.

**Panel meters:** voltmeter and ammeter indicate voltage and current of four internal batteries and 5060A with five position dc check switch.

**Power requirements:**

6 or 12 V dc ±10% ±20%; or 24 to 30 V dc; or 115 ±15 V ac, or 230 ±30 V ac, 50-400 Hz. POWER switch selects 6 or 12 V dc, 115 or 230 V ac inputs.

24 to 30 V dc input on GR terminal. Can be connected simultaneously with ac or other dc power inputs for extra standby reserve.

**Output connectors:**

AC: CA-3102R-10SL-3S.

DC: MS-3102R-14S-5S.

**Input connectors:**

6 and 12 V dc: MS-3102R-16-11P.

24 to 30 V dc: GR type connector.

AC: MS-3102R-14S-7P.

**Battery:** four paralleled, 20 series Ni-Cd cell, 3.5 amp hour, rechargeable batteries that can be individually removed from the circuit without interfering with power supply operation.

**Weight:** net, 67 lbs.

### Specifications

#### 5060A Cesium beam frequency standard

See HP 5060A specifications, page 535

H20-115BR frequency divider and clock

#### Pulsed outputs

Characteristic	Time Tick	Auxiliary Pulse	Positive 1 kHz PPS
Pulse Rate	1 pps	1 pps	1000 pps
Amplitude	— 15 Vp	+ 4 V min, open ckt. — 2 V min, into 50Ω	— 4 V min.
Rise Time	< 0.5 μsec	1 μsec max.	2 μsec max.
Duration	> 40 μsec	100 μsec	20 μsec min.
Jitter	< 0.05 μsec	1 μsec max.	1 μsec max.
Recommended Load Impedance	1000 ohms min, shunted by 200 pF max.	50 ohms min, shunted by 5000 pF max.	1000 ohms min, shunted by 1000 pF max.

**Temperature stability:** time tick, 0.02 μsec/°C.

**Time reference:** continuously adjustable, calibrated in 1 μsec increments.

Numerical display from 999.99 ms to 000.00 ms, in-line vernier in 1 μsec increments.

**Time reference dial linearity:** ±1 μsec.

**Specifications listed are unique to the H20-115BR; see also HP 115BR specifications, page 542.**

## STANDBY POWER SUPPLIES

For Frequency and Time Standards  
Models 5085A, 724BR, 725AR



### FREQUENCY, TIME STANDARDS

#### Advantages:

- 2 amperes at 24 volts
- Up to 21 ampere-hours of standby
- Solid state, modular

#### Uses:

- Continued operation of primary standards when ac line power is interrupted

The HP Model 5085A 24-volt 2 ampere power supply keeps primary frequency or time standard systems in operation when ac line power is interrupted. Specifically designed to deliver standby power to the HP 5060A Cesium Beam Standard and peripheral equipment, the 5085A will also serve HP Quartz Oscillator Frequency Standards and the 115BR/CR Frequency Divider and Clock. The only requirement is that the total current drawn from the supply not exceed 2 amp for any extended period of time.

The frequency and time standard system is not affected during changeover since no switching is used in transferring power from line to battery operation and back again.

Vented nickel-cadmium batteries with an 18 ampere-hour guaranteed capacity (derated from 25) are used in the 5085A. They provide about 12 hours of standby power for the 5060A Cesium Standard (at average ambient temperature of 25°C).

Front panel lights indicate mode of operation, report fuse failure, ac interrupt.

#### Specifications, 5085A

- Output voltage:** 24  $\pm$  2 volts dc at rated current.
- Maximum rated current (total external load):** 2 amperes.\*
- Standby capacity:** (At 25°C\*\*) 18 ampere hours after 48 hours with manually operated CHARGE switch set to CHARGE
- Alarm indicators:** Panel lamps indicate: (1) FUSE FAILURE, (2) AC POWER, (3) AC INTERRUPT, (4) CHARGE.
- Remote alarm provisions:** SPDT relay contacts provided at rear terminals for operating remote alarm from separate power system. Contacts rated at 3 amps (resistive) 115 Vac or 28 Vdc.
- Panel meters:** Voltmeter and ammeter indicate battery voltage and battery charge/discharge current.
- Power requirements:** 115 or 230  $\pm$  10% V ac; 50 to 1,000 Hz (2.0 amps max. at 115 V line).
- Output connectors:** MS type female connectors at rear mate with 106AR, 107AR, 115CR, 5060A power cables (Cannon Part No. 71468-MS3102R14S-5P, HP No. 1251-0111).
- Battery (supplied):** Vented nickel-cadmium 25 ampere-hour rated capacity. Periodic maintenance required.
- Additional (external) battery provision:** MS3102R14S-2S female connector, with cap. at rear.
- Dimensions:** 16 $\frac{3}{4}$ " wide, 6-31/32" high, 18 $\frac{3}{8}$ " deep (425 x 177,2 x 467 mm).
- Weight:** 1net, 75 lbs (34,1 kg), shipping, 101 lbs (45,9 kg) including battery. Option 01 (no batteries) is 50 lbs (22,8 kg) less.
- Accessories furnished:**
  - AC Power Line Power Cable, 6 feet long.
  - Instrument Extension Slides (for std. 24" deep rack).
- Price:** Model 5085A (complete with batteries), \$1,250.
- Options:** specify Option 01 if batteries are to be excluded. Model 5085A with Option 01 is \$820.

\* 2.5 amp for 30 minutes.

\*\* Derate capacity to 75% at high temperature (50°C) and low temperature (0°C).

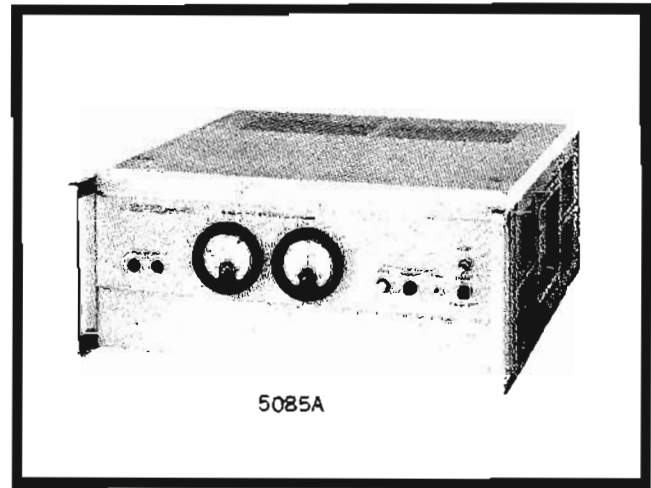

#### 724BR, 725AR Supplies

Models 724BR and 725AR Standby Power Supplies provide standby power (and in certain cases driving power) for Hewlett-Packard frequency and time standard systems. They are compatible with HP Quartz Oscillators 103AR, 104AR, 106A/B, 107AR/BR and with the 115BR/CR Frequency Divider and Clocks.

Since the HP 107AR or 106A requires the full output, added equipment such as the 115BR would require a second power supply; for such combinations, the HP Model 5085A would be a better choice.

#### Specifications, 724BR, 725AR

- Output voltage:** 24 V, +1, -2 Vdc.
- Rated current (total external load):** 500 mA.
- Short circuit protection:** prevents damage from momentary short circuits (e.g., when connecting loads) and from overloads of up to twice rated output; continuous overload reduces instrument's life expectancy.
- Alarm Indicators:** panel lamps indicate operating voltage as (1) ac line or (2) battery, additional lamps indicate ac line fuse failure (remote alarm provision is included).
- Panel meters:** voltmeter and ammeter indicate battery voltage and battery charge/discharge current.
- Power:** 115 or 230 Vac  $\pm$  10%, 50 to 1000 Hz.
- Battery supplied:** 724BR: 25 ampere-hour vented nickel-cadmium; 725AR: 2 ampere-hour sealed nickel-cadmium.
- Output connectors:** MS type female connectors at rear mate with 106A/B, 107AR/BR, 115BR or 115CR connectors.
- Accessory furnished:** power cable, 54 in. long (1372 mm), with NEMA line plug and MS3106A10SL-3S plug for rear-chassis power connector.
- External battery provision:** MS310214S-2S female connector at rear.
- Dimensions:** 724BR: 19" wide, 7" high, 14 $\frac{1}{4}$ " deep behind panel (483 x 177 x 361 mm); 725AR: 19" wide, 3 $\frac{1}{2}$ " high, 12 $\frac{3}{4}$ " deep behind panel and allowing for connectors (483 x 89 x 323 mm).
- Weight:** 724BR: net 75 lbs (34 kg), shipping 101 lbs (45,7 kg), including battery; 725AR: net 27 lbs (12,2 kg), shipping 34 lbs (15,4 kg), including battery.
- Price:** 724BR with 25 amp-hr vented Ni-Cd battery, \$950; 725AR with 2 amp-hr sealed Ni-Cd battery, \$645.
- Option 01:** 724BR without battery, \$600.



## QUARTZ OSCILLATORS

State-of-the-Art frequency stability

Models 106A, B and 107AR, BR Plus 100E, 101A Oscillators

### Advantages:

High Spectral Purity  
Solid-State Reliability

### Uses:

In-house frequency and time standards  
Microwave spectroscopy  
Comparisons with atomic standards  
Advanced navigation, communication systems

Models 106A,B and 107AR,BR Quartz Oscillators provide state-of-the-art application in precision frequency and time standard systems because of their excellent long- and short-term stability characteristics, spectrally pure outputs, unexcelled reliability and ability to operate under a wide range of environmental conditions.

Models 107AR,BR are rugged, hermetically sealed oscillators, employing 5 MHz quartz crystal resonators. The 107 has been designed and tested to meet the stringent shock and vibration requirements of MIL-E-16400E. The oscillators are totally impervious to moisture and will remain stable within  $\pm 1$  part in  $10^{10}$  between 0°C and 50°C.

The heart of the 106A,B is an extremely stable 2.5 MHz quartz crystal. The 106 is distinguished by its long-term

stability of  $\pm 5$  parts in  $10^{11}$  per day (24 hours) and excellent short-term stability over a wide range of environmental conditions.

Models 106A and B are identical in every respect except for their power requirements. The 106B operates from 115 or 230 volts ac line or from an external dc power supply (HP 724BR or 5085A recommended) and contains an emergency standby power supply capable of sustaining operation for 8 hours. The 106A requires an external supply voltage of 22 to 30 V dc, such as the HP 724BR, 725AR, or 5085A.

*100E, 101A Quartz Oscillators*—These instruments are very stable oscillators for applications requiring something less than the stability provided by highly sophisticated frequency standards such as the 106A,B or the 107AR,BR. The 100E has short-term stability of 3 parts in  $10^8$  and is ideal for test, production and lab use. Output frequencies are 10 Hz, 100 Hz, 1 kHz, 10 kHz, 100 kHz, 1 MHz sinusoidal and 10 Hz, 100 Hz, 1 kHz, 10 kHz pulse. Output pips from the timing comb are at 100, 1000 and 10,000  $\mu$ sec intervals. Price: HP 100E, \$1100 (cabinet); HP 100ER, \$1100 (rack mount). The HP 101A One MHz Oscillator is designed as a time base for the HP 5275 Time Interval Counter. Stability is 5 parts in  $10^9$  per week. Price: HP 101A, \$600 (cabinet with rack hardware).

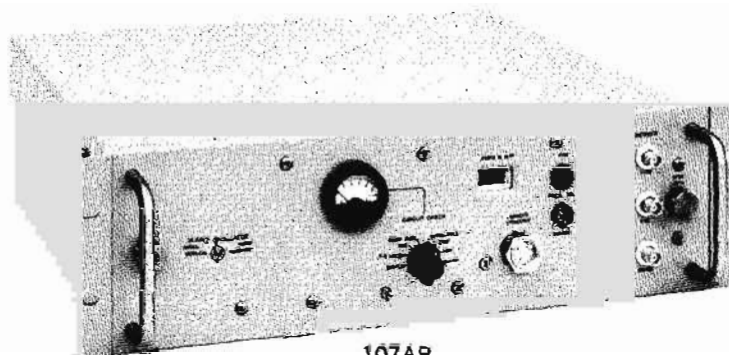

107AR

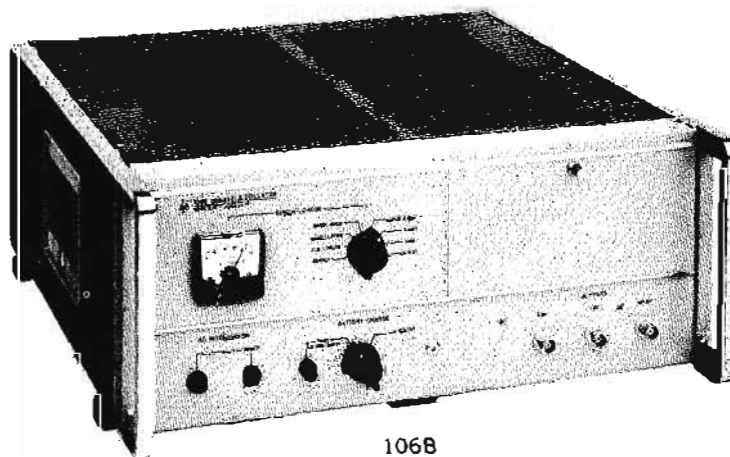

106B

## Specifications

Models	107A,B	106A,B	
Output frequencies	5 MHz, 1 MHz, 100 kHz sinusoidal; 100 kHz clock drive		
Output voltages	5MHz, 1 MHz, and 100 kHz, 1 V rms into 50 ohms; 100 kHz for driving HP frequency divider and clocks, 0.5 V rms into 1000 ohms		
Stability (long term)	$\leq 5 \times 10^{-10}$ per 24 hrs	$\leq 5 \times 10^{-11}$ per 24 hrs	
As a function of ambient temperature	$\leq 1 \times 10^{-10}$ from 0° to +50°C	$\leq 1 \times 10^{-10}$ from 0° to +40°C	
As a function of humidity	instruments are hermetically sealed	basic oscillators are sealed	
As a function of load	$\leq 2 \times 10^{-11}$ for any resistive load change		
As a function of supply voltage	(107A) $\leq 5 \times 10^{-11}$ for 22 to 30 V dc	(106A) $\leq 3 \times 10^{-11}$ for 22 to 30 V dc	
As a function of line voltage	(107B) $\leq 1 \times 10^{-11}$ for 10% change from 115 or 230 V ac	(106B) $\leq 1 \times 10^{-11}$ for 10% change from 115 or 230 V ac	
RMS deviation of 5 MHz (short-term stability)	averaging time	max. rms fractional-frequency deviation ( $\Delta f/f$ )	max. rms phase deviation (milliradians)
	1 msec	$8 \times 10^{-10}$	0.03
	10 msec	$1.5 \times 10^{-10}$	0.04
	0.1 sec	$1.5 \times 10^{-11}$	0.04
	1 sec	$1.5 \times 10^{-11}$	0.4
	10 sec	$1.5 \times 10^{-11}$	4
Noise-to-signal ratio (5 MHz)	at least 87 dB below rated 5MHz output; output filter bandwidth is approximately 125 Hz		
Harmonic distortion (5 MHz, 1 MHz, and 100 kHz)	down more than 40 dB from rated output		
Non-harmonically related output (5 MHz, 1 MHz, and 100 kHz)	down more than 80 dB from rated output		
Output terminals	5 MHz, 1 MHz, 100 kHz, front and rear BNC connectors; 100 kHz clock drive, rear BNC connector		
Frequency adjustments			
Fine adjustment	5 parts in $10^8$ total; 1 part in $10^9$ per rev; 1 part in $10^{10}$ per division at 10 divisions per revolution	2 parts in $10^8$ total; 1 part in $10^{10}$ per rev; 1 part in $10^{11}$ per division at 10 divisions per revolution	
Coarse adjustment	1 part in $10^6$ ( $\approx 0.5 \times 10^{-6}$ )	5 parts in $10^7$ ( $\approx 2.5 \times 10^{-7}$ )	
Environmental			
Storage temperature	-65°C to +85°C (mfr. specifies -40°C to +50°C limit for 107BR battery storage)	-40°C to +75°C (mfr. specifies -40°C to +50°C limit for 106B battery storage)	
Operating temperature	0°C to +50°C	0°C to +40°C	
Humidity	instrument is hermetically sealed, will operate under water without degradation of performance		
Vibration and shock	completely passes vibration and shock requirements of MIL-E-16400E		
Weight	107A: net 20 lbs (9 kg), shipping 38 lbs (17 kg); 107B: net 35 lbs (16 kg), shipping 53 lbs (24 kg)	106A: net 25 lbs (11.3 kg), shipping 33 lbs (15 kg); 106B: net 39 lbs (17.6 kg), shipping 47 lbs (21.3kg)	
Dimensions			
Height	5-7/32" (133 mm)	6-31/32" (177 mm)	
Width	19" (483 mm)	16 1/4" (425 mm)	
Depth	16 3/8" (416 mm)	16 3/8" (416 mm)	
Power	107A: 22 to 30 V dc, approx. 12 w operating, 15 w during warm-up; 107B: 115 or 230 V ac $\approx 10\%$ , 50 to 1000 Hz, approx. 25 w operating with battery on trickle charge (30 w on fast charge), 33 w during warm-up (38 w on fast charge)	106A: 22 to 30 V dc, negative ground, approx. 8 w operating, 13 w during warm-up; 106B: 115 or 230 V ac $\approx 10\%$ , 50 to 1000 Hz, negative ground approx. 17 w operating with battery on trickle charge (27 w on fast charge), 33 w during warm-up (43 w on fast charge)	
Price	HP 107A, \$2400 HP 107B, \$2750	HP 106A, \$3450 HP 106B, \$3900	



## VLF COMPARATOR

Compares frequency against NBS standard  
Model 117A

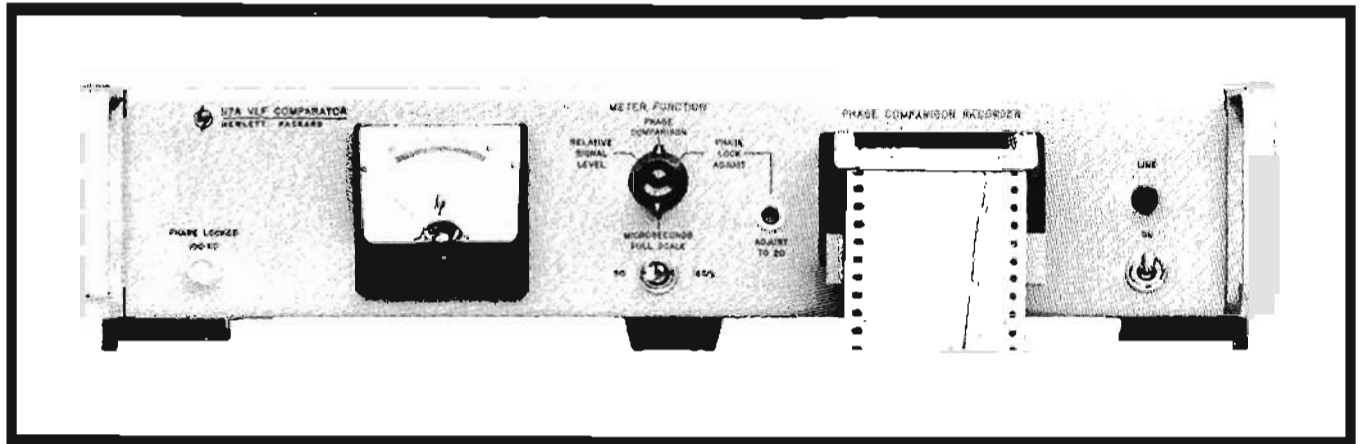

### Advantages:

- Plots minute-by-minute phase record
- Provides all equipment needed for frequency comparison
- Offers one microsecond resolution
- Makes available 100 kHz phase-locked output

### Uses:

- Offset and drift determinations for crystal oscillators
- Quick and easy checks of counter time-base accuracy
- Monitors atomic standards against USFS

The HP 117A VLF Comparator measures the frequency offset of a local standard frequency source against a radio signal based on the U.S. Frequency Standard to an accuracy that can reach a few parts in  $10^{11}$  in a 24-hour period. The HP 117A thus provides a link between house frequency standards and the Boulder, Colorado laboratories of the National Bureau of Standards (NBS) via station WWVB, which broadcasts at 60 kHz on a continuous basis.

The strip chart produced by the HP 117A records minute by minute the results of a precision phase comparison of the local signal against the received signal to show frequency offset or error of the local standard, and over a few hours to a day or more, its drift rate.

Local precision frequency sources such as quartz crystal oscillators that drive clocks or synthesizers or that serve as counter time bases can be quickly compared in frequency for purposes of calibration or can be monitored over as long a time as desired to determine their behavior and to measure long-term drift rate.

### Method of Operation

The VLF Comparator is a complete system (exclusive of local standard) which consists in one package of a receiver, an electronic servo-controlled oscillator which functions as a narrow band tracking filter, a linear phase comparator, and a strip chart recorder. The servo loop and phase-locked oscillator provide a continuous output signal despite noise and interfering signals. A front panel meter can be switched to show relative signal level, phase lock with WWVB, or phase comparison. Output terminals on the rear provide for the connection of external galvanometer and potentiometer recordings if desired. A loop antenna with built-in preamplifier and 30 meters of lead-in cable is included.

The recorded trace is easily evaluated directly in terms of

frequency offset with a transparent template supplied with the instrument. Chart speed is 1 inch per hour and full-scale chart width may be set for either 50  $\mu\text{sec}$  or 16-2/3  $\mu\text{sec}$  by operation of a front panel switch. The readability of the trace and the overall stability of the comparator easily provide a resolution of better than 1  $\mu\text{sec}$  under normally encountered laboratory conditions.

### NBS Standard Broadcast WWVB

The WWVB 60 kHz signal reaches a primary service area that includes the entire continental United States. NBS controls the broadcast frequency to within  $\pm 2 \times 10^{-11}$  of its intended value. NBS publishes monthly, in *Proceedings of the IEEE*, frequency correction data relative to WWVB and also to the other standard broadcasts, which are WWV and WWVH (high frequency) and WWVL (20 kHz).

WWVB is referenced to the U.S. Frequency Standard and its frequency is *not* offset. WWVB seconds pulses are those of the time scale NBS-A, for which time interval is the international (atomic) second. (Frequency of the other NBS services is offset by an amount coordinated through the Bureau International de l'Heure: for 1966, offset is  $-300 \times 10^{-10}$ . Purpose of the offset is to make the second of time interval correspond closely to that of UT-2, the time scale in ordinary use.)

Accuracy of the HP 117A approaches that of the broadcast signal itself. The HP 117A takes advantage of the phase-stable nature of the lower frequencies to make possible quick comparisons to accuracies far exceeding those achieved by use of the older high frequency services. In the continental U.S., frequency standard comparisons to an accuracy of a part in  $10^{10}$  can be approached in an 8-hr. period. A 24-hr. period may give 2 parts in  $10^{11}$ , and a 30-day period may give accuracies of parts in  $10^{12}$ . The local standard being calibrated must, of course, be of a quality commensurate with the realization of such high accuracies.

### Template

A transparent template, overlaid on the HP 117A's strip chart recording, enables the operator to read at a glance the frequency offset of his local standard. The template curve most nearly matching the chart's trace is selected, then offset is read directly, together with its sign. The sign indicates whether local frequency lies above or below reference frequency.

## Atomic and UT-2 Time Scales

Many users prefer to maintain their local frequency standard referenced to the interval of UT-2, the time scale in ordinary use, rather than to NBS-A (these two scales are explained at the beginning of the "Frequency and Time Standards" section). Use of a translator kit adapts the 117A for UT-2 service. Hewlett-Packard offers two translators:

The 00117-91027 Translator Kit installs in the 117A. A power-line-driven synchronous motor and gear train rotate a phase shifter to continuously retard the phase of the WWVB signal, thereby decrease the frequency. Power-line frequency changes of 0.1% cause translation errors of only about  $1.5 \times 10^{-11}$ . Most lines average much less than 0.1% frequency deviation over extended periods.

The K10-117A Translator is a separate instrument for use external to the 117A. It also uses a motor-driven phase shifter. It shifts the frequency of, and derives its time base from, the external 100 kHz (1 MHz, optional) source being compared with WWVB, and is unaffected by line frequency. The direction of translation can be changed.

In both translators, the correct gear ratio is supplied for coordinated frequency offset in effect at time of purchase. Different gear ratios will be available at a nominal charge to change the translation ratio when the offset is changed. The 117A is available with the 00117-91027 translator installed (see Specifications).

## Antenna

The loop antenna supplied with the 117A contains a preamplifier which allows at least 300 meters of cable (30.5 meters supplied) between antenna and receiver. The cable's center conductor carries power to the preamplifier.

Antenna location and orientation are important. For best signal pick-up it should be mounted on the roof (it is sealed against the weather) and oriented with the plane of the loop aligned with signal direction.

## Additional Information

A complete discussion of the use of lower frequency broadcasts in frequency standardization is included in Hewlett-Packard Application Note 52, "Frequency and Time Standards."

## Phase Comparison Record

The slope of the trace plotted by the 117A's strip chart recorder is, at a given instant, frequency offset between the local standard and the received signal. This slope may be read at a glance with the transparent template supplied with the instrument. Two offset readings separated by a span of time usually chosen to be one day give all data needed to allow a determination of the drift rate of the local standard (drift rate is given by the difference in offset over a specified elapsed time).

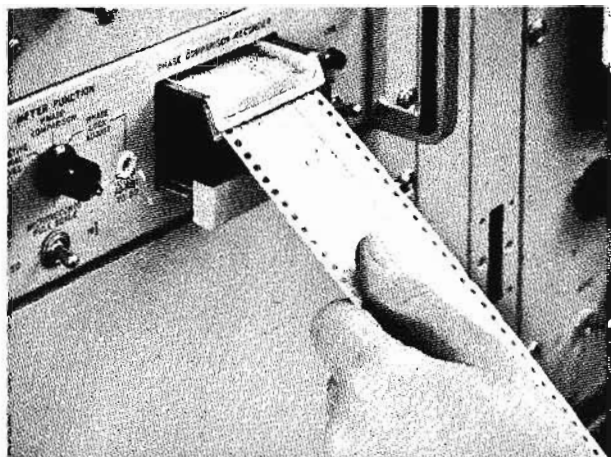

Greatest accuracy results when the user selects the times he makes observations to fall in a period when propagation conditions are stable, as revealed by the nature of the trace. VLF signals are normally highly stable when the entire propagation path is in sunlight. Near sunrise and sunset, the diurnal shift makes an apparent change in the offset.

Any VLF Comparator is but one element of the system which the user must consider: (1) transmitted signal, (2) transmission path, (3) VLF comparator, and (4) local standard. Since the first two elements are not under the user's control, he must make his observations in accordance with reception conditions. While VLF signals are noted for their stability, variations in propagation conditions do exist and must be taken into account.

## European Service from MSF Rugby

The 60 kHz broadcast from MSF Rugby, which was extended to provide 24 hour service in the summer of 1966, has been successfully monitored with a standard 117A unit at Geneva. MSF is operated by England's National Physical Laboratory.

Received signal strength was entirely satisfactory and indicates a good possibility that the MSF service can be received throughout Western Europe.

## Specifications, 117A

**Received standard frequency:** 60 kHz, NBS station WWVB.

**Sensitivity:**  $1 \mu\text{V}$  into  $50 \Omega$

**Local standard input:** 100 kHz, 1V rms into  $1000 \Omega$  (divider to accept 1 MHz at extra cost).

**100 kHz phase-locked output:** 5V rectangular positive pulses into  $5000 \Omega$ .

**60 kHz test output:** self-checks the 117A.

**Recorder outputs:** phase comparison and relative signal strength: 0.1 mA dc into  $1400 \Omega$  and 0.100 mV dc from  $2000 \Omega$ .

**Overall phase stability:**  $\pm 1 \mu\text{sec}$  0-50°C.

**Chart speed:** 1 in/hr (6 or 12 in/hr available).

**Chart width:** 50  $\mu\text{sec}$  or 16-2/3  $\mu\text{sec}$  (selected by front panel switch).

**Meter readings:** three switch positions: (1) relative signal level; (2) phase comparison calibrated scales 0-50  $\mu\text{sec}$ , 0-16 2/3  $\mu\text{sec}$  full scale; (3) phase-lock range indicated insures negligible phase error.

**Adjustments:** a front panel control adjusts free-running frequency of voltage-controlled oscillator; three rear panel adjustments provide calibration of phase comparison, full-scale adjustment for internal recorder, internal meter, and external galvanometer recorder.

**Storage temperature:**  $-50^\circ$  to  $+75^\circ\text{C}$ .

**Operating temperature:** 0 to  $50^\circ\text{C}$ .

**Dimensions:** 16 3/4" wide, 3-15/32" high, 13 1/4" deep (425 x 88 x 337 mm).

**Weight:** 117A: net 20 lbs (9.1 kg), shipping 22 lbs (10 kg); antenna: net 12.5 lbs (5.7 kg), shipping 21 lbs (9.5 kg).

**Power:** 115 or 230 V  $\pm 10\%$  60 cycles, 40 watts.

## Accessories (included)

**10509A loop antenna:** antenna has electrical height of 1.6 mm, is 43 in. (109 cm) diameter and mounts on 1-in. pipe thread. Operating temperature:  $-60^\circ$  to  $+80^\circ\text{C}$ . Also available separately (for use only with HP 117A), \$280.

**10512A Coaxial lead-in cable:** 50  $\Omega$  BNC-BNC connectors 100 feet (30.5 m) long. Also available separately, \$30.

**Accessories (not included with 117A):**

**Time scale translators:**

00117-91027 translator kit, \$300.

K10-117A translator, \$800.

**9281-0081 recorder chart paper:** box of six 30-ft rolls, \$12.50.

**Prices:** 117A including 10509A antenna/pre-amp and 10512A lead-in cable, \$1,300.

H21-117A: is model 117A with 0117-91027 translator installed, \$1,575.





## FREQUENCY DIVIDER, CLOCKS

Time comparison capability to  $\pm 10 \mu\text{sec}$

Models 115BR, 115CR

### Advantages:

- Generates precise time signals
- In-line digital readout
- Compatible with atomic or quartz frequency standards
- Suitable for mobile applications

### Uses:

- Frequency and time standard systems
- Time comparisons against broadcast time signals

The HP 115BR and 115CR Frequency Divider and Clocks generate precise time signals, offer the convenience of digital readout, and provide features which make possible highly accurate comparisons against national time standards. Detailed records of oscillator drift rates and of time and frequency differences can be obtained.

Time readout is an in-line digital display of hours, minutes and seconds. An additional drum allows an operator to resolve time visually to 0.1 sec or by stroboscopic methods to 0.01 sec.

Overall time comparison accuracy is  $\pm 10 \mu\text{sec}$  and the divided outputs are virtually free from jitter. The time reference control is a precision resolver and the unique optical gate system cannot contribute jitter.

Hewlett-Packard Application Note 52 explains in detail how a time comparison system, set up to use precise time signals from WWV or another standard broadcast, can yield timekeeping accuracy to within a millisecond and enable studies of oscillator frequency drift rate and error. For micro-second accuracy a portable master clock is an ideal means for establishing this reference.

Success of time comparisons, typically made over periods of weeks or months, depends upon continuous operation. Premium electrical and mechanical components used in the 115BR/CR insure maximum reliability. The non-self-starting regenerative dividers avoid noise and spurious signal problems.

### Driving standard

The 115BR/CR input frequency is 100 kHz. Recommended driving standards include the HP 106A/B, 107AR/BR Quartz Oscillators and the HP 5060A Cesium Beam Standard.

### BCD time signals

By the addition of a Time Encoder, the 115BR/CR provides BCD time-of-day signals in addition to the standard output frequencies and visual time display.

### Specifications, 115BR,CR

**Input frequency:** 100 kHz for ordinary time, input bandwidth  $\pm 300 \text{ Hz}$ ; 100.3 kHz for sidereal time, on special order.

**Input voltage:** 0.5 to 5 V rms.

**Pulse outputs:** (see chart).

**Accuracy:** same as input frequency.

**Input impedance:** 300 ohms nominal.

**Auxiliary output:** (115BR only): amplitude, 0.25 V rms minimum; source impedance, approx. 1200 ohms; frequency, 100, 10 and 1 kHz (60 Hz on special order).

**Time reference:** continuously adjustable, calibrated in 10  $\mu\text{sec}$  increments; numerical display from 999.9 msec to 000.0 msec, in-line vernier in 10  $\mu\text{sec}$  increments.

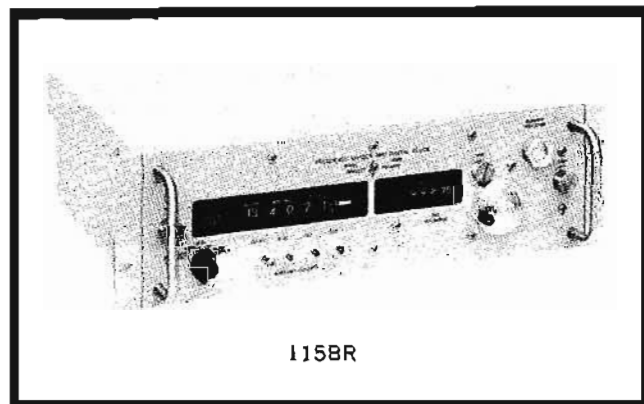

115BR

**Effect of transients:** will not gain or lose time because of: (1)  $\pm 300 \text{ V}$  step function on 100 kHz input; (2) 0 to 50 V pulses, 0 to 500 pps, 1 to 10  $\mu\text{sec}$  duration on 100 kHz input; (3)  $\pm 4 \text{ V}$  step in 26 Vdc input.

Characteristic	Positive tick	Negative tick	Auxiliary pulse*	Positive** 1 kHz pips
Pulse rate amplitude	1 pps $+10 \text{ V}^{***}$ min.	1 pps $-10 \text{ V}^{***}$ min.	1 pps $+4 \text{ V}$ min. open ckt, $+2 \text{ V}$ min. into 50 ohms	1000 pps $+4 \text{ V}$ min.
Rise time	2 $\mu\text{sec}$ max.	2 $\mu\text{sec}$ max.	1 $\mu\text{sec}$ max.	2 $\mu\text{sec}$ max.
Duration	20 $\mu\text{sec}$ min.	20 $\mu\text{sec}$ min.	200 $\mu\text{sec}$	20 $\mu\text{sec}$ min.
Jitter	1 $\mu\text{sec}$ max.	1 $\mu\text{sec}$ max.	1 $\mu\text{sec}$ max.	1 $\mu\text{sec}$ max.
Recommended load impedance	4700 ohms min. shunted by 200 pF max.	1 megohm min. shunted by 100 pF max.	50 ohms min. shunted by 5000 pF max.	1000 ohms min. shunted by 1000 pF max.

\*Standard for 115BR, available for 115CR.

\*\*Negative pulses available on special order.

\*\*\*For any load impedance higher than minimum recommended.

**Monitor meter:** (115BR only), checks supply voltage, divider operation (100 kHz, 10 kHz, 1 kHz) and total clock current.

**Power:** 22 to 30 Vdc, negative ground for operating with 106A,B or 107AR,BR (may be selected by a switch), approximately 2.5W, recommended supply, 724BR or 725AR (positive ground).

### Environmental tests:\*

115BR only: The 115BR Frequency Divider and Clock has been prototype-tested to pass the following military environmental specifications.

1. **Temperature:** MIL-E-16400C, Class 4, Paragraph 4.6.7. (Nonoperating test limits:  $-40^\circ\text{C}$  to  $-60^\circ\text{C}$ .)
2. **Humidity:** MIL-E-16400C, Paragraph 4.6.8.
3. **Vibration:** MIL-E-16400C, Paragraph 4.6.14.
4. **Inclination:** MIL-E-16400C, Paragraph 4.6.14.
5. **Shock:** MIL-E-16400C, Paragraph 4.6.14.

The 115BR is an airtight and watertight instrument.

**Dimensions:** 115BR: 19" wide,  $5\frac{1}{4}$ " high, 12" deep behind panel (483 x 133 x 356 mm); 115CR: 19" wide,  $3\frac{1}{2}$ " high, 12" deep behind panel (483 x 89 x 305 mm).

**Weight:** 115BR: net 35 lbs (15.8 kg), shipping 51 lbs (23.0 kg); 115CR: net 15 lbs (6.8 kg), shipping 25 lbs (11.0 kg).

**Accessories furnished:** 113A-16E Cable, 6 feet long (1830 mm), connects 115BR or 115CR to 724BR, 725AR, or 5085A standby power supply.

**Price:** HP 115BR, \$2750; HP 115CR, \$1500.

\*These environmental specifications apply to the 115BR without the optional time encoders. For complete information regarding the ability of the 115BR (and time encoders) to pass military specifications, write Hewlett-Packard.





locked to signals derived from the standard.

The direct synthesis approach has the pronounced advantages of permitting fine resolution, fast switching, and a spectrally pure output signal. Also, direct synthesis is fail-safe. A system using indirect synthesis will provide an erroneous signal when a failure not suspected by the operator causes the variable frequency oscillator to become unlocked or to lock to the wrong frequency.

### The synthesis operation

The 5100A/5110A and the 5105A/5110B synthesizers are made up of two completely solid-state units: the synthesizer proper, and the driver.

The driver contains a frequency source, a spectrum generator, and appropriate selective networks. The source is a high quality crystal oscillator housed in an oven. It is well protected from line voltage variations, and has an aging rate of less than 3 parts in  $10^9$  per day. A crystal filter at the oscillator output limits the noise bandwidth to about 150 Hz.

The spectrum generator is a step-recovery diode. Active filtering, synchronously tuned transistor stages and frequency dividers provide a series of fixed frequencies between 3 and 39 MHz which are fed to the synthesizer unit.

The synthesizer unit contains harmonic generators and suitable mixers, dividers, and amplifiers to derive the desired output frequency as a function of the fixed frequencies. The front-panel pushbuttons actuate a diode switching matrix. All frequencies appearing at the inputs to this matrix are always present. This is one of the key advantages of the direct synthesis method. The limitations on switching speed are just the time constants on the filtering circuits in the supply line to the switch and circuit bandwidths.

### High-speed switching

The oscillogram of Figure 1 shows the speed which is typical of Hewlett-

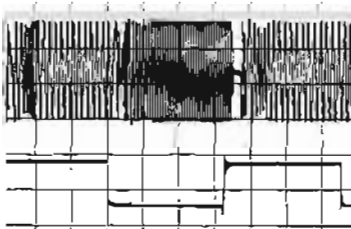

Figure 1. Switching speed, Model 5103A: 1.2 MHz to 2.7 MHz, 30 kHz switching rate. 5  $\mu$ sec/cm, 10 MHz Range.

Model No.	Range	Minimum Step
5100A/ 5110A	0.01 Hz to 50 MHz	0.01 Hz
5102A	0.1 Hz to 1 MHz 0.01 Hz to 100 kHz	0.1 Hz 0.01 Hz
5103A	1 Hz to 10 MHz 0.1 Hz to 1 MHz	1 Hz 0.1 Hz
5105A/ 5110B	0.1 to 500 MHz	0.1 Hz

All of the Hewlett-Packard Synthesizers offer digital selection from a push-button keyboard or by remote switch closure, and in addition, a search oscillator for continuously variable frequency selection. All derive their output frequency by the direct synthesis technique, one capable of translating the stability and spectral purity of the source to the selected output. All have a self-contained 1 MHz source, a precision quartz oscillator of excellent stability, and all can use in its place an external 1 MHz or 5 MHz standard.

### Direct vs. indirect synthesis

Two basic approaches to frequency synthesis are "direct" and "indirect". Direct synthesis simply performs a series of arithmetic operations on the signal from the frequency standard to achieve the desired output frequency. In indirect synthesis, a master oscillator is phase

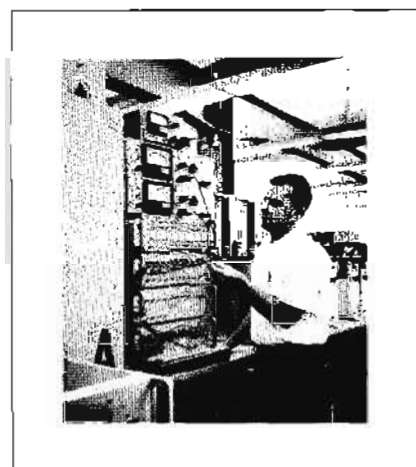

Figure 2. Stability monitoring equipment.

Packard synthesizers when they change output frequency under electronic command. The upper waveform is synthesizer output; the lower is the externally applied switching voltage. Note the virtual absence of dead time and switching transients.

### Signal purity

Two of the central design objectives for the Hewlett-Packard synthesizers were (1) virtual elimination of non-harmonically related spurious signals and (2) the reduction of noise to as low a level as possible. Noise appears as a small, random phase modulation which adversely affects the short-term stability of a signal.

Performance of the Model 5100A/5110A is typical of Hewlett-Packard synthesizers and attests to the attainment of these objectives: non-harmonically related signals are at least 90 dB below the selected frequency, and signal to phase noise ratio is greater than 54 dB (in a 30 kHz noise bandwidth centered on the signal, with a 1 Hz central band excluded).

At Hewlett-Packard, a considerable number of engineering years have been spent on problems of frequency stability and its measurement. Routine production line tests are made on frequency stability with use of specially designed equipment of a sophistication not often found even in frequency measurement research laboratories. Figure 2 shows a multi-channel short-term frequency stability monitor used to check each Hewlett-Packard synthesizer driver. This equipment monitors both rms and peak phase noise of all the driver outputs at the same time and shows an alarm light if any one of the set limits is exceeded.



## FREQUENCY SYNTHESIZER

0.1 to 500 MHz in 0.1 Hz increments

Model: 5105A - 5110B

### Advantages:

- Frequencies from 0.1 MHz to 500 MHz
- Push-button selection in 0.1 increments, plus Search oscillator
- Remote programming
- Switching speed typically 20  $\mu$ sec
- Spurious 70 dB down
- All solid state, modular construction

### Uses:

- Offers new levels of spectral purity and stability for such applications as:
  - Accurate doppler measurements
  - Microwave spectroscopy
  - Narrow-band telemetry
  - Automatic testing of frequency-sensitive devices
  - Communications systems

The Model 5105A Frequency Synthesizer, a new member of the Hewlett-Packard group of synthesizers, extends frequency synthesis capability to 500 MHz. The 5105A provides push-button or remote selection of any frequency from 0.1 to 500 MHz in steps as small as 0.1 Hz. The 5105A shares with the other Hewlett-Packard synthesizers the utilization of direct synthesis. This technique translates the stability and spectral purity of the source to the selected output, and in addition, provides a fail-safe output. The 5110B Synthesizer Driver described on page 548 supplies the 22 fixed frequencies required as input to the 5105A. The 5110B is capable of driving up to four 5105A Synthesizers. Source for the frequencies is a precision 1 MHz quartz oscillator of excellent stability. If desired for special applications, an external 1 MHz or 5 MHz frequency standard can be used instead. These features, plus additional ones to be desired, establish the 5105A-5110B as a precision variable frequency standard which brings a new capability to the frequency range 0.1 to 500 MHz.

### Phase modulation

A phase modulation input is a useful new feature incorporated in the 5105A. This input (rear panel) allows phase modulation of any output frequency at a maximum deviation of 3 radians with a deviation rate up to 1 MHz. For those applications requiring frequency modulation, a simple integrator network could be placed in series with this input to convert the phase modulator to an FM modulator.

### Continuous Tuning, Sweep, FM

A search oscillator provides continuously variable frequency selection over the range of any one column except the tens and hundreds of megahertz columns (the left-hand two). Operation of a front-panel control manually tunes the search oscillator over the complete frequency range of the selected digit, that is, over incremental ranges from 1.0 Hz through 10 MHz. One of the advantages afforded by

continuous control is the easy identification of an unknown frequency by beating it against the synthesizer output.

The search oscillator also may be controlled by application of a dc voltage ( $-1$  to  $-11$  volts, linearity  $\pm 5\%$ ) which enables remote operation and gives sweep capability.

The search oscillator can be frequency modulated from an external source (sinewave) at a maximum rate of 1 kHz while retaining the voltage control calibration.

### Remote operation

The 5105A-5110B offers control flexibility never before possible in a precision frequency source of its range. Any frequency or search oscillator position available from the keyboard can be remotely selected and can be rapidly switched: in 20  $\mu$ sec, typically.

Rear panel connectors on the 5105A provide pins corresponding to each front panel pushbutton, a ground connection, and a  $-12.6$  volt line for use in remote programming. A combination of remote and local programming may be used, if so desired.

No actual contact closure, such as a relay, is required. The  $-12.6$  volts dc may be applied to the selected pin by electronic means.

The remarkably fast switching speed, valuable for such tasks as automatic digital frequency tracking, is one of the significant advantages of the direct synthesis method. There are no phase-locked loops which must settle to a final value when output frequency is changed.

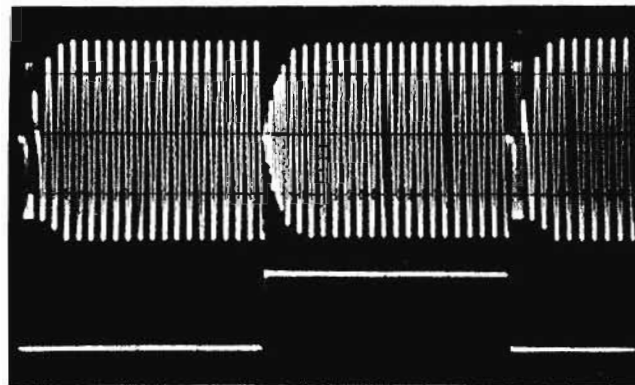

Figure 1. Synthesizer switching speed.

### Fast switching

Figure 1 shows (upper trace) the 5105A-5110B output frequency switched between 399.8 MHz and 400.2 MHz with 400 MHz subtracted to display switching in greater detail. The sweep is 25  $\mu$ sec/cm. The lower trace is that of the switching waveform applied to the synthesizer.

### Low noise performance

To achieve the excellent low-noise output specified for the 5105A-5110B synthesizer over the full range requires the utmost care in design to identify and minimize noise sources followed by extensive testing at each stage of manufacture.

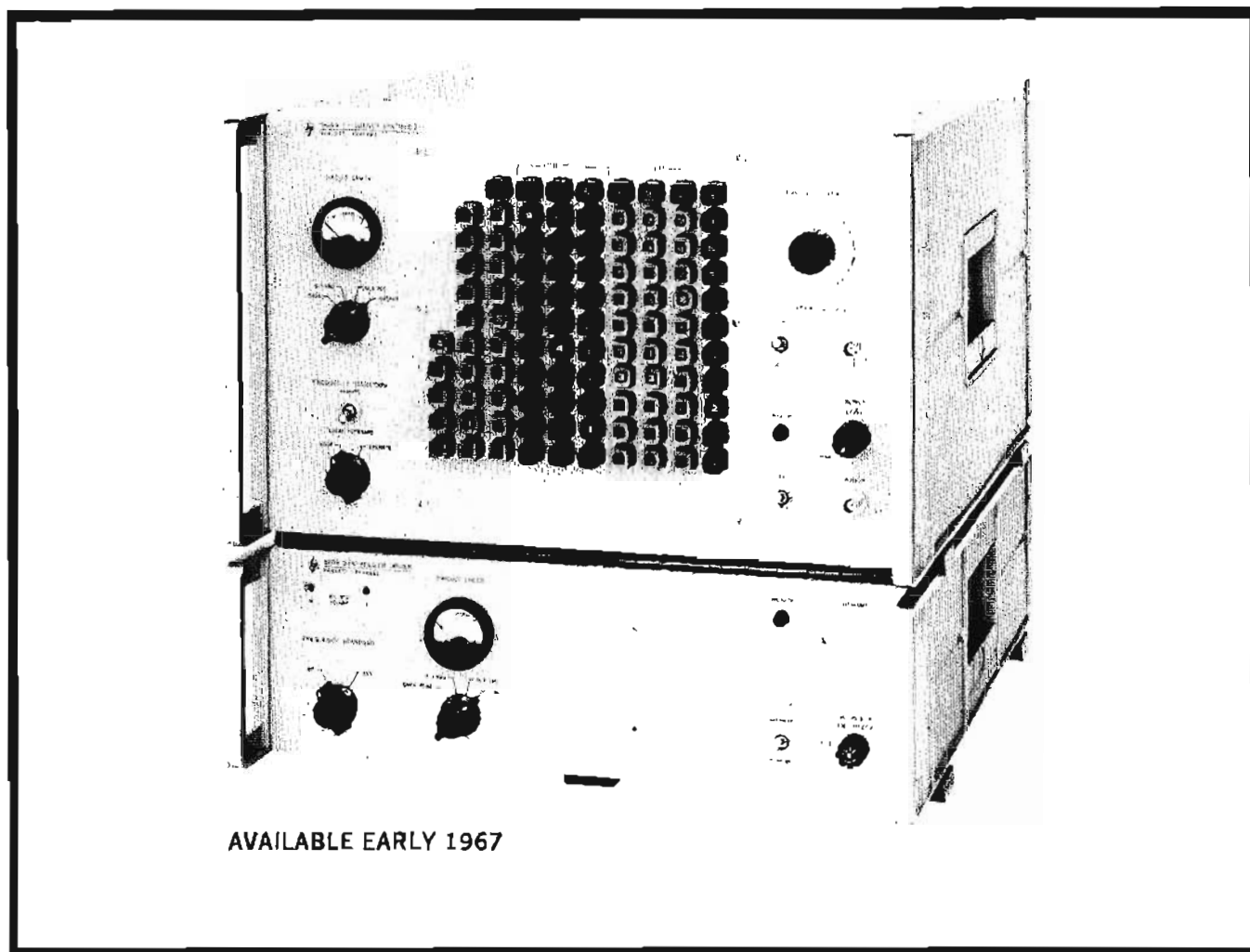

AVAILABLE EARLY 1967

Figure 2 shows phase noise distribution at 500 MHz. The ratio of output signal to single-sideband phase noise (in a 1-Hz bandwidth) is plotted against frequency of offset from the signal.

The noise performance reflected in this plot is remarkable for an instrument as complex and versatile as the 5105A-5110B, and demonstrates its suitability for applications where spectrum requirements are critical. One such application would be as a local oscillator in a single-sideband communications system, both for transmitters and for receivers.

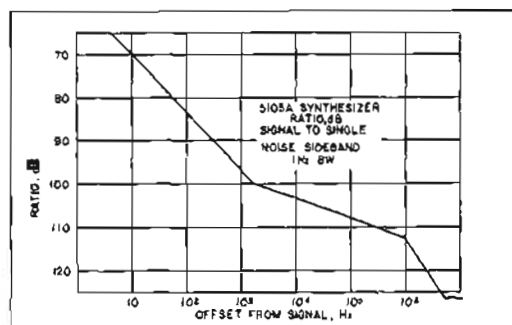

Figure 2. Log plot of phase noise.

### Spectral purity and stability

Spurious content is at least 70 dB below the selected output. This reflects the extremely high level of spectral purity and stability achieved for the 5105A-5110B by advanced design.

Many applications require that a signal be multiplied. If the frequency multiplying device is broadband, the ratio of total sideband power to signal power increases as the square of the multiplying factor; since total power is constant, the increased sideband power must come from the carrier. The spectrum begins to spread, owing to intermodulation.

To achieve a signal having a good spectrum after high multiplication requires that the original signal have the highest possible signal-to-phase noise ratio. The 5105A has a signal-to-phase noise ratio (measured in a 30 kHz band centered on the signal, excluding the 1 Hz central band) which is excellent:

- At 1 MHz, 48 dB
- At 100 MHz, 48 dB
- At 500 MHz, 40 dB

### Specifications

Specifications for the 5105A Synthesizer are presented on page 547. Specifications for the 5110B Synthesizer Driver are presented on page 548.



## FREQUENCY SYNTHESIZER

dc to 50 MHz, 5 billion discrete frequencies  
Model 5100A/5110A

### Advantages:

- Digital frequency selection
- 0.01 Hz frequency increments
- Spurious 90 dB down
- Remote programming
- Switching speed typically 20  $\mu$ sec

The Hewlett-Packard Model 5100A/5110A Frequency Synthesizer provides any output frequency from 0.01 Hz to 50 MHz, selectable in steps as small as 0.01 Hz. The output frequency is derived from a precision single frequency source through direct synthesis, a technique which translates the stability and spectral purity of the source to the selected output. A precision 1 MHz quartz oscillator is provided, or an external 1 MHz or 5 MHz standard may be used.

### Spectral purity

Particular care has been exercised in the design of the Model 5100A/5110A to insure that a very clean output signal is provided over the entire frequency range. A high order of spectral purity is essential for accurate doppler measurements, microwave spectroscopy, narrow band telemetry or communications, and similar applications. The design and construction of the 5100A-5110B make it possible to obtain output signals with a spurious content at least 90 dB below the selected output.

The 5110A Synthesizer Driver generates 22 spectrally pure signals from the standard signal. These 22 frequencies are then fed to the 5100A Frequency Synthesizer by means of rear panel BNC connectors and are continuously available. The variable output signal is synthesized from these fixed frequencies by a series of arithmetic operations.

### Fast switching

Since no phase-locked loops are involved, switching from one output frequency to another can be accomplished very rapidly, either from the front panel pushbuttons or remotely. Typically, 20  $\mu$ sec are required to change output frequency.

### Remote control

Any frequency or search oscillator position that can be selected by front panel pushbuttons can also be remotely selected. Connectors located on the 5100A rear panel provide pins corresponding to each front panel pushbutton position, a ground connection, and a -12.6 volt line for use in remote programming. The -12.6 volts is available in two arrangements — continuous and switched. This lends additional versatility since it enables the use of a combination of remote and local programming.

An actual contact closure such as a relay is not required for remote control of the Synthesizer. The required -12.6 volts dc may be applied to the selected pin electronically.

### Modular construction

Modular construction has been used throughout the 5100A/5110A. The modular concept enables the system to

meet stringent demands regarding spurious signals since the isolation that it affords minimizes spurious coupling. It also enhances serviceability. Careful design and quality control insure that all modules are interchangeable from one instrument to another.

### Search oscillator

The search oscillator can be selected either locally or remotely and swept either locally or remotely. Besides facilitating searching for an unknown frequency, the search feature permits frequency modulation of the output at a maximum sinewave rate of 1000 Hz, phase locking the synthesizer into another system, or sweep operation with a sweep range as small as 0.1 Hz. The incremental range of the search oscillator is between 0.1 Hz and 1 MHz, depending upon the column selected for search. Any one of the right-hand eight columns may be searched.

### Simple operation

Operation of the 5100A-5110A is straightforward. The output frequency is selected simply by depressing one pushbutton in each of the 10 columns of pushbuttons. Any frequency that can be selected by the pushbuttons can be programmed remotely. The Lock-Operate switch prevents accidental operation of the pushbuttons. The Circuit Check switch and meter on both the 5100A and 5110A provide quick and easy checks of internal circuits. The Frequency Standard switch selects either the 1 MHz internal quartz oscillator or an external frequency standard, if desired.

### Specifications

The table on the facing page lists specifications for the 5100A Synthesizer. The 5110A Synthesizer Driver is presented on page 548.

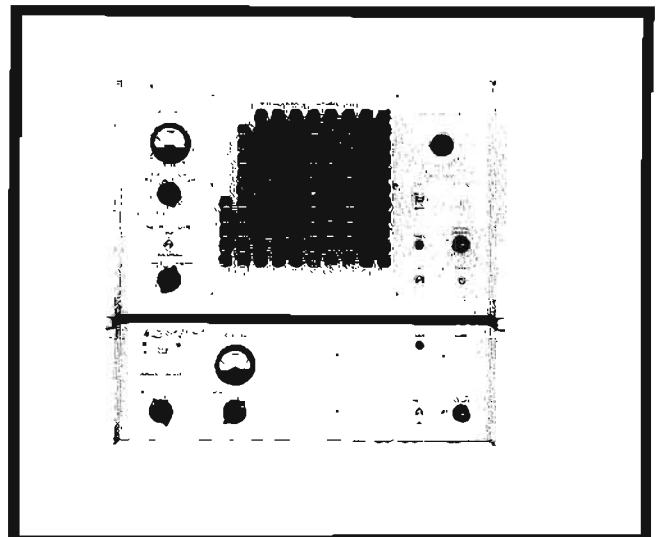

**Specifications**  
**5105A, 5100A Synthesizers**

Specifications	5105A*	5100A*										
Output frequency	0.1 to 500 MHz	dc to 50 MHz										
Digital frequency selection	0.1 Hz through 100 MHz per step. Selection by front panel pushbutton or by remote switch closure. Any change in frequency may be accomplished in 20 $\mu$ sec typically.	0.01 Hz through 10 MHz per step. Selection by front panel pushbutton or by remote switch closure. Any change in frequency may be accomplished in 20 $\mu$ sec typically.										
Output voltage	Fixed: 0 dBm $\pm$ 1 dBm into a 50-ohm resistive load. Variable: -6 dBm to $\geq$ 6 dBm into a 50-ohm resistive load.	1 volt rms $\pm$ 1 dB from 100 kHz to 50 MHz. 1 volt rms +2 dB, -4 dB from 50 Hz to 100 kHz, into a 50-ohm resistive load. Nominal source impedance is 50 ohms. 15 mV rms minimum open circuit from 100 kHz down to dc, at separate rear output connector, source impedance of 10,000 ohms with shunt capacitance approximately 70 pF.										
Search oscillator	Provides continuous variable frequency selection with an incremental range of 1.0 Hz through 10 MHz. Manual or external voltage (-1 to -11 volts) control with linearity of $\pm$ 5%.	Provides continuously variable frequency selection with an incremental range of 0.1 Hz through 1 MHz. Manual or external voltage (-1 to -11 volts) control with linearity of $\pm$ 5%.										
Phase modulation	(rear panel input) $\pm$ 3 radians maximum deviation; dc -1 MHz rate.											
Signal-to-phase noise ratio	Measured in a 30-kHz band centered on the signal (excluding a 1 Hz band centered on the signal) is greater than: <table border="1" style="margin-left: 20px;"> <tr> <td>Output frequency—MHz</td> <td>1</td> <td>50</td> <td>100</td> <td>500</td> </tr> <tr> <td>Ratio—dB</td> <td>48</td> <td>48</td> <td>48</td> <td>40</td> </tr> </table>	Output frequency—MHz	1	50	100	500	Ratio—dB	48	48	48	40	Greater than 54 dB in a 30-kHz band centered on the signal (excluding a 1-Hz band centered on the signal).
Output frequency—MHz	1	50	100	500								
Ratio—dB	48	48	48	40								
Signal-to-AM noise ratio	(Above 100 kHz): Greater than 74 dB in a 30 kHz band.											
RMS fractional frequency deviation (with a 30-kHz noise bandwidth)**	Averaging time	Output frequency										
		1 MHz    50 MHz    100 MHz    500 MHz										
	10 milliseconds 1 second	<table border="1" style="margin-left: 20px;"> <tr> <td>1 <math>\times</math> 10<sup>-7</sup></td> <td>2 <math>\times</math> 10<sup>-9</sup></td> <td>1 <math>\times</math> 10<sup>-9</sup></td> <td>6 <math>\times</math> 10<sup>-10</sup></td> </tr> <tr> <td>2 <math>\times</math> 10<sup>-9</sup></td> <td>4 <math>\times</math> 10<sup>-11</sup></td> <td>2 <math>\times</math> 10<sup>-11</sup></td> <td>1 <math>\times</math> 10<sup>-11</sup></td> </tr> </table>	1 $\times$ 10 <sup>-7</sup>	2 $\times$ 10 <sup>-9</sup>	1 $\times$ 10 <sup>-9</sup>	6 $\times$ 10 <sup>-10</sup>	2 $\times$ 10 <sup>-9</sup>	4 $\times$ 10 <sup>-11</sup>	2 $\times$ 10 <sup>-11</sup>	1 $\times$ 10 <sup>-11</sup>		
1 $\times$ 10 <sup>-7</sup>	2 $\times$ 10 <sup>-9</sup>	1 $\times$ 10 <sup>-9</sup>	6 $\times$ 10 <sup>-10</sup>									
2 $\times$ 10 <sup>-9</sup>	4 $\times$ 10 <sup>-11</sup>	2 $\times$ 10 <sup>-11</sup>	1 $\times$ 10 <sup>-11</sup>									
Spurious signals	Non-harmonically related signals are at least 70 dB below the selected frequency.	Non-harmonically related signals are at least 90 dB below the selected frequency.										
Harmonic signals	25 dB below the selected frequency, (applicable to fixed output when terminated in 50 ohms).	30 dB below the selected frequency (when terminated in 50 ohms).										
Dimensions	16 $\frac{3}{8}$ " wide, 16 $\frac{3}{8}$ " deep, 10-15/32" high (425 x 416 x 266 mm).											
Weight	net, 75 lbs (34 kg); shipping, 133 lbs (61 kg).											
Equipment furnished	Decade test cable: 05105-6054/55. Cable Assembly (connects 5105A Synthesizer to 5110B Driver) permits up to approx. 2.5 feet vertical separation.	05100-6180 Decade Test Cable, 05100-6066 Output Cable, 05100-6212/13 Cable Assembly connects 5100A Synthesizer to 5110A Driver. Permits rack mounting a 5100A up to approx. 2.5 ft. above or below the 5110A Driver. A special-length-cable assembly will be required for other mounting arrangements.										
Special cable	Special cable available. Specify configuration and length (50 ft. max.). Cable is supplied in five-foot increments. Price: \$40 per five-foot increment.	If a special-length cable assembly is required, order spec C05-5110A. Specify configuration and length (max. separation 50 feet). Cable is supplied in five-foot increment only. Price: \$40 per five-foot increment.										
Price	Available early in 1967	\$8,150. (requires 5110A)										

\*5105A requires 5110B Driver; 5100A requires 5110A Driver.

\*\*Note: When the 5110B Driver utilizes an external frequency standard, this will affect the stability and spectral purity of the output. Performance data stated above are based on internal frequency standard or indicate synthesizer contribution to overall performance with external standard.

## FREQUENCY, TIME STANDARDS



## SYNTHESIZER DRIVERS

For the 5100A and 5105A Synthesizers  
Models 5110A, 5110B

The HP 5110B Synthesizer Driver supplies the HP 5105A Synthesizer with 22 fixed, spectrally pure signals derived from a 1 MHz precision quartz oscillator. The HP 5110A Synthesizer Driver performs the same function for the HP 5100A Synthesizer.

The frequency synthesizer system comprising the 5105A Synthesizer and the 5110B Driver provides output frequencies from 0.1 to 500 MHz in increments as small as 0.1 Hz. The 5100A - 5110A system provides output frequencies from dc to 50 MHz in increments as small as 0.01 Hz. These synthesizers are described on pages 544-546.

The 1 MHz quartz oscillator which is the source for all output frequencies of the synthesizer driver is stable to  $\pm 3$  parts in  $10^9$  per 24 hours. To help maintain this excellent crystal stability, oven circuits are energized any time the instrument is connected to the power line. A circuit check meter allows verification of correct oven operation.

Where special requirements make it necessary that synthesized frequencies be derived from an external frequency standard, a rear panel connector on the 5110A and the 5110B accepts a 1 MHz or 5 MHz signal. Substitution of an external standard results in having the characteristics of the synthesized frequencies made partially dependent upon the characteristics of the external standard.

These synthesizer drivers are each capable of driving up to four synthesizers. Drivers equipped in accordance with Options 02 through 04, for driving from two to four synthesizers, must have additional outputs not in use terminated in 50 ohms in order that full specified spurious performance be met.

### Specifications Synthesizer Drivers 5110A, 5110B For the 5100A and 5105A Synthesizers\*

**Output frequencies:** For their respective synthesizers the drivers provide 22 fixed frequencies as follows: 3.0 through 3.9 MHz in 0.1 MHz steps (50 mV  $\pm 1$ ,  $-3$  dB), 30 through 39 MHz in 1 MHz steps, and 24 MHz; plus (1) for the 5100A, the 5110A provides 3 MHz (100 mV  $\pm 1.5$  dB, 50-ohm system), (2) for the 5105A, the 5110B provides 20 MHz (100 mV  $\pm 1.5$  dB, 50-ohm system). 1 MHz buffered output (1 V  $\pm 1.5$  dB into a 50-ohm resistive load) available at rear panel connector.

#### Internal frequency standard:

**Type:** 1 MHz Quartz Oscillator.

**Aging rate:** Less than  $\pm 3$  parts in  $10^9$  per 24 hours.

**Stability:** As a function of ambient temperature:  $\pm 2 \times 10^{-10}$  per  $^{\circ}\text{C}$  from  $0^{\circ}\text{C}$  to  $+55^{\circ}\text{C}$ . As a function of line voltage  $\pm 5 \times 10^{-11}$  for a  $\pm 10\%$  change in line voltage (rated at 115 or 230 volts rms line voltage).

#### RMS Fractional Frequency Deviation:

Average Time	1 MHz Output Frequency
10 millisecc	$6 \times 10^{-10}$
1 sec	$1 \times 10^{-11}$

\*Use the 5110A with the 5100A; the 5110B with the 5105A.

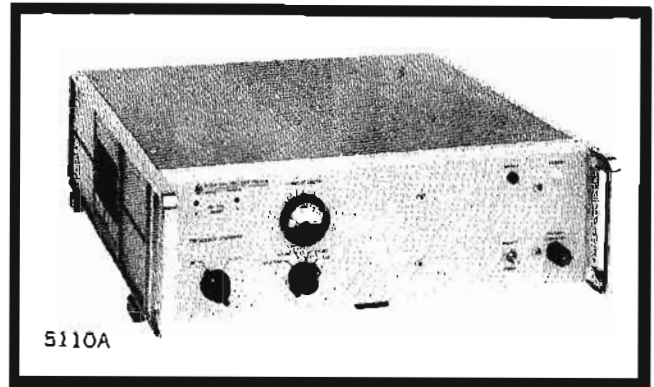

**Signal-to-phase noise ratio:**\*  $> 85$  dB.

**Signal-to-AM noise ratio:**\*  $> 80$  db.

**Harmonic signals:**  $> 40$  dB below the output (with proper termination).

**Phase-locking capability:** A voltage control feature allows 5 parts in  $10^8$  frequency control for  $-5$  to  $+5$  volts applied externally.

**External frequency standard input requirements:** 1 MHz or 5 MHz, 0.2 V rms minimum, 5 V maximum across 500 ohms. Stability and spectral purity of Frequency Synthesizer will be partially determined by the characteristics of the external standard if used.

**Dimensions:** 16  $\frac{3}{4}$ " wide, 5-7/32" high, 16  $\frac{3}{8}$ " deep (425 x 133 x 416 mm).

**Weight:** Net, 54 lbs (25 kg). Shipping, 60 lbs (27 kg).

**Operating temperature range:** 0 to  $+55^{\circ}\text{C}$ .

**Interference:** Complies with MIL-I-26600, Class 1 and 3, MIL-I-6181D.\*\*

**Susceptibility:** Complies with MIL-I-26600, Class 1 and 3, MIL-I-6181D.

**Power:** 115 or 230 volts  $\pm 10\%$ , 50 to 400 cycles, 35 watts.

**Optional features:** The Synthesizer Drivers are capable of driving up to four Frequency Synthesizers:

Option 02, outputs for driving two synthesizers, \$125; Option 03, for three, \$235; Option 04, for four, \$345.

#### Notes:

1. For Options 02-04, if full specified spurious performance is required, outputs not connected to a Synthesizer must be terminated in 50 ohms. (Accessory No. 10510A, 22 required for each set of outputs not connected, \$5 each.)

2. Special interconnecting cable may be required.

3. Small phase jumps may be experienced in additional synthesizer when first is switched in frequency.

**Price:** \$4350.

\*In a 30 kHz band centered on the carrier, excluding a 1 Hz band centered on the carrier.

\*\*Interference compliance requires that the 5105A and 5110B are connected by a low inductance path such as adjacent rack mounting.

## FREQUENCY SYNTHESIZERS

Broad frequency coverage, dual-range  
Models 5102A, 5103A



**FREQUENCY, TIME STANDARDS**

The HP Models 5102A and 5103A Frequency Synthesizers increase synthesizer capability, providing instruments with dual-output frequency ranges of 100 kHz and 1 MHz (5102A), and 1 MHz and 10 MHz (5103A).

The 5102A provides output frequencies from 0.01 Hz to 100 kHz and from 0.1 Hz to 1 MHz in increments of 0.01 Hz and 0.1 Hz respectively. Output frequencies from 0.1 Hz to 1 MHz in increments of 0.1 Hz, and from 1 Hz to 10 MHz in 1 Hz increments are provided by the 5103A. Both instruments synthesize the output frequency from a single frequency source, translating the stability of the source to the output frequency via a direct synthesis technique. A very stable quartz oscillator, provided with each synthesizer, or an external 1 MHz (or 5 MHz) frequency standard may be used as the frequency source.

A Level control on the front panel allows continuous adjustment from 300 mV to 1 volt rms, of frequencies (greater than 50 Hz) available at the front-panel BNC. For frequencies below 50 Hz, the signal is taken from a rear-panel Low Level output BNC. Frequencies available at the rear-panel BNC have a signal strength of approximately 80 mV for the 5102A and 20 mV for the 5103A.

### Dual-range feature

The two distinct (dual) frequency ranges of the 5102A and 5103A provide the user with extended capability at minimum cost and without sacrifice of a convenient module size. The upper range extends the frequency capability of each model, at the same time retaining high levels of stability and spectral purity. The higher frequency capability has frequency increments that are the same percentage of the range maximum as in the lower frequency range.

The choice of frequency range is dependent on the maximum frequency required and is selected by the Range switch located on the front panel. The Range switch also positions a moveable label bar, conveniently indicating the decimal value of each column of pushbuttons. For both ranges the output frequency is selected three ways.

With the Frequency Select switch in the Local position, the output frequency is selected by seven columns of pushbuttons, arranged for rapid frequency selection. A locking switch is provided to prevent accidental operation of the pushbuttons once they are set. In addition, the full range of each column may be continuously varied either manually or externally by a search oscillator. Any frequency or search oscillator position locally controlled may be remotely selected via rear-panel connectors to each of the front-panel pushbuttons. The Frequency Select switch is positioned in Remote for remote control. Combined local-remote operation also is possible with the switch in the Local position. Any column not locally selected may be remotely controlled. Less than 20  $\mu$ sec are required to switch between frequencies in the local mode of selection and also in the remote mode if proper impedance levels are selected for the remote controller. The switching speed is very rapid and accurate, due to the direct synthesis technique used, which eliminates slower, hard to synchronize phase-locked loops.

The search oscillator provides continuous tuning in any selected column plus an external sweep capability. This is an L-C oscillator which allows the operator to continuously "search" any significant column from 1 MHz to 0.1 Hz either manually by a front-panel control or remotely by application of a suitable voltage. The typical voltage vs frequency characteristic is shown in Figure 1. The approximate slope is

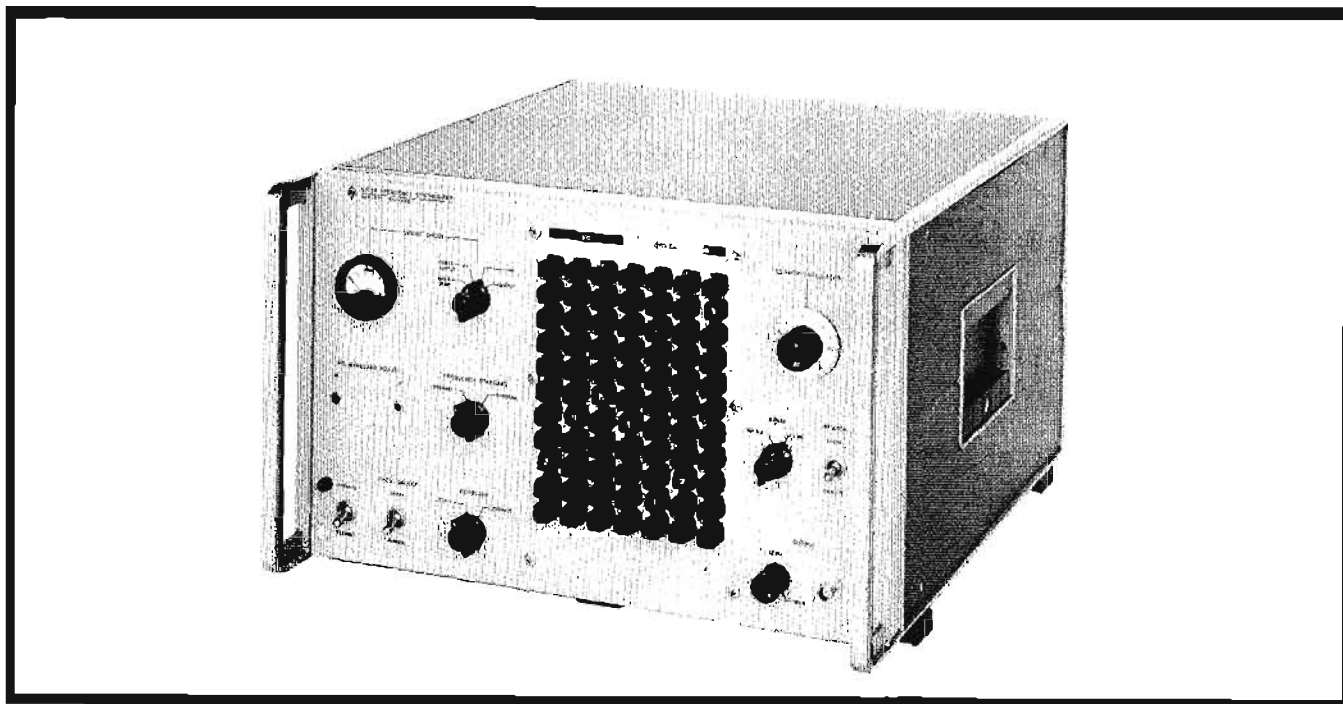



10% of the selected column's range per V. The search oscillator may be frequency modulated from an external source at a maximum sine wave rate of 1 kHz while retaining the voltage control calibration.

If the search oscillator is used, the stability of the synthesizer output is determined by either that of the standard instrument or that of the search oscillator—depending on the column which is "searched."

Outputs from the 5102A and 5103A are very clean over the full frequency ranges. Careful design and solid-state modular construction yield the high order of spectral purity essential for applications requiring clean and stable frequencies.

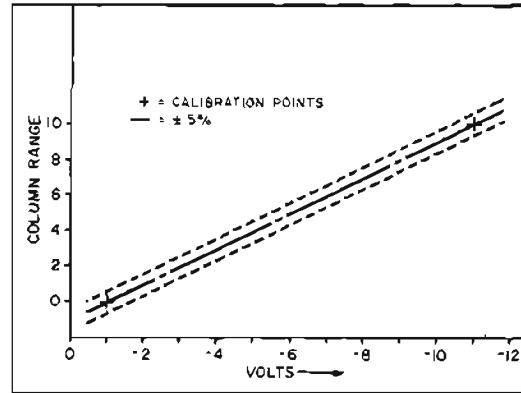

Figure 1.

Specifications

HP Model	5102A	5103A				
Output frequency:	100 kHz range: 50 Hz to 100 kHz; 1 MHz range: 50 Hz to 1 MHz	1 MHz range: 50 Hz to 1 MHz; 10 MHz range: 50 Hz to 10 MHz				
Output voltages:	Maximum output 1 V rms $\pm$ 1 dB into 50 $\Omega$ resistive load. Level control (front panel output BNC) provides a minimum of 10 dB continuously variable attenuation.					
Auxiliary outputs:	(1) Low level: dc to value of range, both ranges (rear-panel BNC); (2) $f_0 + 30$ MHz ( $f_0$ is selected frequency, dc to 1 MHz, both ranges) rear-panel BNC; (3) 1 MHz frequency standard (rear-panel BNC)					
Auxiliary output voltage:	(1) Low level 80 mV rms (minimum) open circuit (2) $f_0 + 30$ MHz: 1 volt rms, $\pm$ 2 dB into a 50 $\Omega$ resistive load (3) 1 MHz: 1 volt rms, $\pm$ 1.5 dB into a 50 $\Omega$ resistive load 20 mV rms (minimum) open circuit					
Digital frequency selection:	100 kHz range: 0.01 Hz to 10 kHz steps; 1 MHz range: 0.1 Hz to 100 kHz steps Selection by front-panel pushbutton or by remote contact closure; any change in frequency may be accomplished in $<$ 20 $\mu$ sec provided appropriate rear-panel connection is used	1 MHz range: 0.1 Hz to 100 kHz steps; 10 MHz range: 1 Hz to 1 MHz steps				
Switching time:	$<$ 20 $\mu$ sec for any change in frequency					
Search oscillator:	Provides continuously variable frequency selection in any desired column over complete range of that column; manual by a front-panel control or by an external voltage ( $-1$ to $-11$ volts)					
Signal-to-phase noise ratio (output)*:	(Output): 100 kHz range, $>$ 74 dB 1 MHz range, $>$ 64 dB ( $f_0 + 30$ MHz): $>$ 60 dB	(Output): 1 MHz range, $>$ 64 dB 10 MHz range, $>$ 54 dB ( $f_0 + 30$ MHz): $>$ 60 dB				
Signal-to-AM noise ratio*:	(Output): 100 kHz range, $>$ 80 dB for frequencies above 30 kHz; 1 MHz range, $>$ 74 dB for frequencies above 100 kHz ( $f_0 + 30$ MHz): $>$ 80 dB	(Output): 1 MHz range, $>$ 74 dB for frequencies above 100 kHz; 10 MHz range, $>$ 74 dB for frequencies above 500 kHz ( $f_0 + 30$ MHz): $>$ 80 dB				
RMS fractional frequency deviation:	(Output):					
	100 kHz range	1 MHz range	1 MHz range	10 MHz range		
	Ave. Time	100 kHz Output Frequency	Ave. Time	1 MHz Output Frequency	Ave. Time	10 MHz Output Frequency
	10 ms	$3 \times 10^{-8}$	10 ms	$1 \times 10^{-7}$	10 ms	$3 \times 10^{-9}$
	1 sec	$3 \times 10^{-10}$	1 sec	$1 \times 10^{-9}$	1 sec	$3 \times 10^{-11}$
( $f_0 + 30$ MHz):	(Output):		(Output):			
Ave. Time	Output Frequency		Ave. Time	Output Frequency		
10 msec	$6 \times 10^{-10}$		10 ms	$6 \times 10^{-10}$		
1 sec	$1 \times 10^{-11}$		1 sec	$1 \times 10^{-11}$		
Spurious signals:	100 kHz range: $>$ 90 dB; 1 MHz range: $>$ 70 dB (below selected output for non-harmonically related signals)	1 MHz range: $>$ 70 dB; 10 MHz range: $>$ 50 dB				
Harmonic signals:	$>$ 35 dB on all ranges, all outputs (with proper termination)					
Internal frequency standard:	1 MHz quartz oscillator					
Internal frequency standard aging rate:	less than $\pm$ 3 parts in $10^9$ per 24 hours					
Stability of internal frequency standard (as function of ambient temp.):	$\pm 2 \times 10^{-10}$ per $^\circ$ C from $0^\circ$ C to $+55^\circ$ C					
(as function of line voltage):	$\pm 5 \times 10^{-11}$ for a $\pm 10\%$ change in line voltage (115 or 230 V)					
External frequency standard:	1 MHz or 5 MHz, 0.2 V to 5 V rms across 500 $\Omega$					
Standard input requirements:	stability and spectral purity of synthesizer will be partially determined by the characteristics of external standard if used					
Operating temperature range:	0 to $+55^\circ$ C					
Dimensions:	16 $\frac{1}{4}$ " wide, 10-15/32" high, 16 $\frac{3}{8}$ " deep (425 x 266 x 416 mm)					
Weight/Power:	net 75 lbs (34 kg); shipping 127 lbs (58 kg)/115 or 230 V $\pm$ 10%, 50-400 Hz, 50 W					
Price:	\$6,500		\$7,100			

\* In a 30 kHz band centered on the carrier, excluding a 1 Hz band centered on the carrier.

## FREQUENCY SYNTHESIZER APPLICATIONS



## FREQUENCY, TIME STANDARDS

Hewlett-Packard Frequency Synthesizers are signal sources (essentially multiple frequency standards) for which output frequency can be selected from a keyboard or by electronic command to a very high resolution. Such an instrument with its extremely high spectral purity and stability constitutes a powerful tool in a wide range of systems and scientific applications.

### Communications

The high spectral purity of synthesizer output signals makes them ideal as local oscillators in receiver applications where very low levels of rf gain are available in the circuitry before the mixer stage.

Their very stable output frequencies make these synthesizers suitable for use in homodyne receiver circuitry. The advantages of using a synthesizer in this application are simplicity and freedom from image problems, both of which plague many receiver designs.

Data handling systems in all areas of industry and military applications use magnetic tape as a storage medium, linking the receiver to the data processing and analysis equipment. However, magnetic tape is not without fault, introducing certain distortions to the data. A synthesizer may be used to eliminate the degrading effects wow and flutter have on information that is received and stored on magnetic tape. This use is facilitated by the ability of the user to bypass the internal crystal filter in the synthesizer driver section. The input reference frequency may be offset by as much as 0.25%, with the same percentage offset translated to any output frequency. Thus, a recorded reference channel on the tape can be used as the reference frequency of the synthesizer, and wow and flutter can be removed by comparing the data channel with a convenient synthesizer output frequency derived from the reference channel.

A surveillance receiver system which monitors multiple data channels by rapidly switching between channels is an ideal area of application for one of the Hewlett-Packard frequency synthesizers. With its rapid, highly repeatable switching capability, a synthesizer will serve as the local oscillator in this type of receiver, providing the proper local oscillator frequency for each channel under surveillance. A similar application arises in radio sounding applications, used to determine the maximum usable frequency allowed by ionospheric conditions. Since

these conditions are always in a state of change, the ability of a synthesizer to generate test transmissions rapidly over the entire hf spectrum makes it an important tool for radio sounding.

The high spectral purity which characterizes the Hewlett-Packard synthesizers allows signal multiplication to microwave frequencies. HP synthesizers are ideal for use as the local oscillator in microwave communications systems.

A laboratory-type receiver capable of flat response over a broad range can easily be arranged with use of one of the synthesizers as the local oscillator, together with a broadband mixer and a narrow-band amplifier. For example, a combination of the HP 5105A/5110B Synthesizer, the HP 10514A Mixer, and the HP 415D SWR Meter exhibits an exceedingly flat response over the range 100 kHz to 500 MHz and a sensitivity greater than  $10^{-16}$  watt.

### Radar

The 5100A/5110A is capable of switching between output frequencies in 0.01 increments at a very fast rate; thus it is capable of making very good approximations of frequency versus time functions. This performance feature finds application in high performance "chirp" radar installations, which require an ultra linear sweep.

In doppler radar applications the Hewlett-Packard frequency synthesizer easily supplies all the necessary requirements for precise velocity measurements. The excellent stability of the synthesizer makes it ideal as the basic signal source in the transmitter, which requires stability capable of staying within a receiver bandwidth only a few cycles wide in the microwave region. For accurate velocity measurements, the transmitted source frequency must be exactly the same after the round trip to the vehicle under scrutiny. A 5100A/5110A or another of the synthesizers also is well suited for use as the local oscillator in the doppler receiver, where the local oscillator must be capable of rapid change in order to keep the returning signal of different frequency within the narrow receiver bandwidth.

### NMR applications

Nuclear magnetic resonance spectroscopy methods are used to determine the qualitative and quantitative structure of molecules. In NMR, the strength of an applied dc magnetic field and the frequency of simultaneously applied rf field

uniquely determine the spin-interaction of nuclei. In this application the broad frequency range and precise 0.01 Hz increments of frequency are very valuable.

### Short-term stability measurements

Hewlett-Packard synthesizers are ideal for use in systems to evaluate short-term frequency stability. Often denoted as phase noise, short-term stability can be characterized by three measures: a phase noise vs. frequency of offset plot, a total measurement of instability over a frequency band, and statistical parameters. Their own excellent stability makes HP synthesizers ideal for use in systems to make these measurements on signal sources (such as oscillators) and on a variety of circuits: amplifiers, limiters, and filters. Systems for phase noise measurement utilizing the synthesizer offer a practical solution to problems of production testing. A synthesizer can serve as the frequency reference and also as the source of excitation for the circuit to be evaluated.

### Synthesizer specials

Since their introduction in 1963, Hewlett-Packard synthesizers have found many unusual applications. Users have been quick to take advantage of synthesizer versatility and have shown great ingenuity in applying synthesizers to many research, manufacturing, and field instrumentation needs that otherwise could have been met only by costly laboratory-designed equipment.

Where none of the standard synthesizers can serve the need, however, Hewlett-Packard engineers in the synthesizer design group stand ready to apply their special knowledge to select, adapt or modify synthesizers to meet a customer's special requirements. It often proves to be the case that needs can be met with instruments built on the production line to narrowed environmental specifications, or with faster switching speed, or with changed output frequency ranges. Whenever possible, the synthesizer group specifies simple modifications that can be made at relatively low cost to the customer, thereby avoiding the far greater expense of special engineering design. Where necessary and warranted, though, this group will devise and build special synthesizers. Discuss your requirements with your Hewlett-Packard field engineer.



Nuclear instruments detect, count and display the occurrence of nuclear events —alpha and beta particles, neutrons and gamma or x-rays. These different radiations occur in the transition of elements from one state to another.

suited. For example, crystals of sodium iodide activated with thallium, NaI(Tl), are particularly suited for detection of gamma radiation. Hewlett-Packard uses this crystal in the integral assemblies in the 10600A Series Scintillation Detectors.

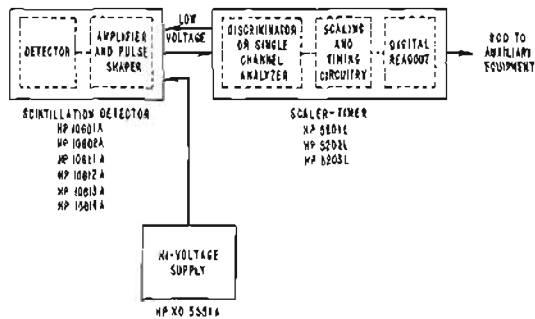

Figure 1. Hewlett-Packard nuclear instrumentation system.

The basic nuclear instrumentation system Hewlett-Packard uses for counting nuclear events is shown in Figure 1. It is a complete system for detecting, counting and displaying gamma radiation. All systems for counting nuclear events contain these basic instruments, although they may be packaged differently. The Hewlett-Packard packaging format, utilizing modular cabinets, provides the most versatile usage over a wide range of applications. In addition, this format is compatible with instruments in existing gamma spectrometers.

By packaging the NaI (Tl) crystal and photomultiplier tube (the integral assembly) and the preamplifier into a detector assembly, by packaging the high-voltage supply separately, and by combining the single-channel analyzer and the scaler-timer in one module, Hewlett-Packard offers instruments grouped so they may be used to count almost every type of nuclear event if the proper detector is used.

There are many types of detectors available, each with an application (type of event counted) for which it is best

### Spectrometer systems

By operating the 5201L Single-Channel Analyzer in the "narrow window —  $\Delta E$  mode," the system may be used for single-channel pulse height analysis. The precision calibration of the 5201L window enables counting of pulses with peaks falling within a window having a width calibrated between zero and 0.5 volt. The ability to quickly establish a very narrow and calibrated window, with high repeatability, has wide application. With the narrow window the user is able to easily analyze the photo peak(s) of radiation samples.

If the window of the single-channel analyzer in the 5201L is swept across the full energy spectrum of a sample, providing total energy spectrum information, the system is a scanning gamma spectrometer. Figure 2 shows how a system utilizing the HP 5552A Spectrum Scanner can be used to sweep the single channel analyzer (in the 5201L) over a particular energy spectrum and provide an X-Y plot of the spectrum on a Moseley 7035A Recorder. A spectrum recorded on this system of Cs<sup>137</sup> is shown in Figure 3.

Substituting the Model 5202L Scaler-Timer for the Model 5201L Single-Channel Analyzer in the spectrometer of Figure 1 provides a simple integral discriminator in place of the single-channel analyzer. The spectrometer is capable of providing gross gamma count information. Connecting a number of scaler-timers with an HP 2514A Digital Scanner to an HP 562A Digital Recorder and/or recording devices such as the HP 2595 Tape Punch Coupler, HP 2526 Card Punch Coupler of the HP 2546 Magnetic Tape Coupler, provides a means for collecting data from many nuclear sources and in numerous forms. Such a system could be used to monitor the radiation of different types of particles from one source, in one case, or, in another, the strength of gamma radiation at various distances from a source or at different positions about a source.

### Applications for gamma spectrometry

The gamma spectrometer configurations described above indicate the far-ranging capability of Hewlett-Packard's nuclear instruments in all areas where gamma (or other nuclear event) spectrometry is of value.

Activation analysis and natural radiation detection are important tools of scientists in both pure and applied scientific research. Radioisotopes are used in medical research, diagnosis and therapy. Industry uses neutron activation analysis in testing for impurity concentrations in products of all forms. For example, the semiconductor industry uses the ability of gamma spectrometers to detect minute quantities of impurities in semiconductor crystals. Law enforcement agencies use spectrometers to detect small quantities of gunpowder, poisons, etc., that have been activated by neutron bombardment, as a tool in crime detection.

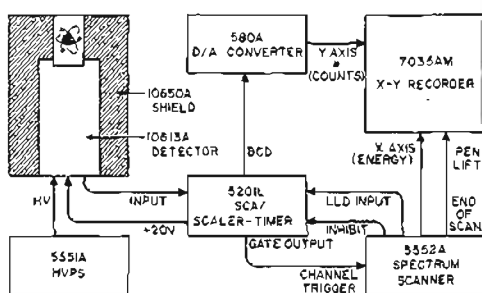

Figure 2. Automatic gamma scanning spectrometer

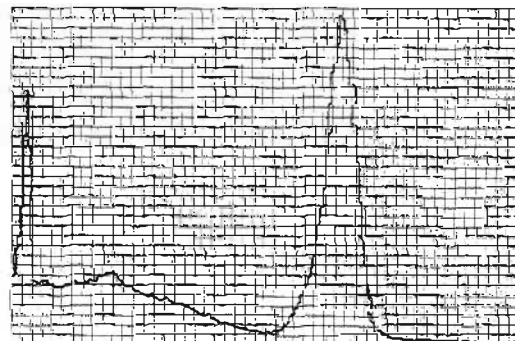

Figure 3. X-Y plot of Cs<sup>137</sup> spectra.

# SPECTRUM SCANNER

For versatile automatic spectrum scanning  
Model 5552A



## NUCLEAR

The HP 5552A Spectrum Scanner is designed for externally programming a single channel pulse height analyzer scaler-timer (such as the 5201L, page 554) for automatic recordings of gamma and x-ray energy spectra. The all-electronic method incorporated by the 5552A produces spectra such as that shown on page 552 (which is a plot of counts versus energy level) and provides very versatile program control.

The 5552A Spectrum Scanner is normally used in systems such as that shown on page 552. The 5552A supplies the voltage for the deflection of the X-Y Recorder pen for the X-axis, and the HO3-581A Digital to Analog Converter converts the data from the 5201L Scaler-Timer for the deflection voltage for the Y-axis. The scaler-timer gates the scanner at the conclusion of a counting interval to allow the generation of the next voltage step. The scanner introduces a delay to permit the pen of the recorder to reach the correct position in the Y direction before moving in the X direction.

The 5552A has control circuitry for scanning either a single spectrum or for continuous automatic rescanning. For the continuous mode the 5552A supplies a command signal to lift the pen of the Moseley 7035A Recorder during its return to the start position. The 5552A enables the operator to stop the scan at any point for repeated counting in any particular channel.

This scanner may be used in systems described above to provide data in a format analogous to that obtained from a multi-channel analyzer.

### Specifications

**$E_{min}$  output:** (decreasing staircase)

**Range:** full scale +4.980 volts to -0.020 volts.

**Full scale:** 50 channels, 100 mV increments; 100 channels, 50 mV increments; 200 channels, 25 mV increments.

**Half scale:** upper 100 channels, 25 mV increments; lower 100 channels, 25 mV increments.

**Integral linearity:** 0.25%, 0°C to 55°C.

**End point stability:** +50 mV to -20 mV around zero and +20 mV to -100 mV around full scale.

**Output impedance:** less than 10 ohms.

**Output current:** maximum: 5 mA.

**Connector:** BNC on rear panel.

**Trigger input:** negative slope 0.1 V/ $\mu$ sec, -5 V peak or gate output from HP Scaler-Timers

**X-Y recorder output**

**Range:** 0 to 100 mV.

**Impedance:** 1 k ohm.

**Integral linearity:** 0.25% (0°C to 55°C).

**End of scan output:** normally closed contact opens for 1 second at end of scan.

**Event marker output:** momentary contact closure to ground at end of the counting period of every 10th channel.

**Inhibit output:** normally open circuit, shorted at arrival of trigger input. Duration of INHIBIT is 960 msec with DELAY switch ON and 15 msec with DELAY switch OFF.

**+24 volt input:** TNC connector on rear panel, 200 mA current drain (maximum).

**Digital recorder output:** (channel number)

**Output:** 4 line 1-2-4-8 BCD code, "1" state negative.

**Impedance:** 100 k ohms.

**Positive state level:** approximately 0 volts.

**Negative state level:** approximately -20 volts.

**Reference levels:** -5 V, 1.2 k ohms source impedance; -10 V, 2.8 k ohm source impedance.

**Print command:** print command not available from 5552A Spectrum Scanner; must be obtained from scaler-timer.

**Power:** 115 V or 230 V ac, 50 Hz to 1000 Hz, 11 watts.

**Weight:** 12 lbs (5.5 kg) net, 17 lbs (7.7 kg) shipping.

**Dimensions:** 16 $\frac{3}{4}$ " wide, 3-15/32" high, 11 $\frac{1}{4}$ " deep (426 x 89 x 286 mm).

**Temperature range:** 0°C to 55°C.

**Accessories furnished:** detachable power cord; rack mounting accessory kit; circuit board extender; two HP 10519A cables, 6 ft. long BNC connectors. HP 10530A cable.

**Price:** 5552 Spectrum Scanner, \$675.

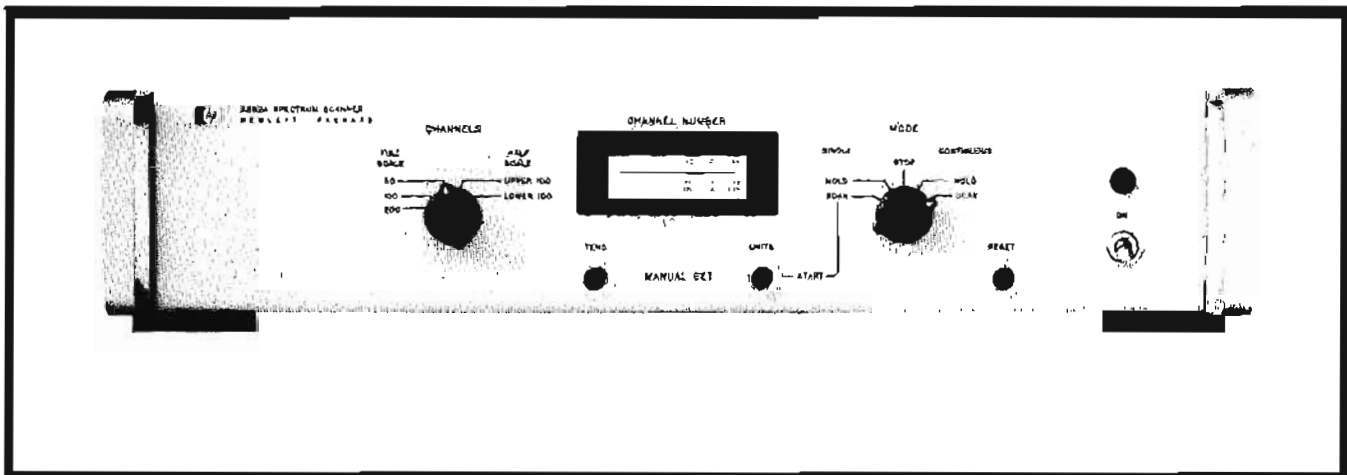



## SCALER-TIMERS

Gross counting and pulse height analysis

Models 5201L, 5202L, 5203L

### Advantages:

- Solid state
- Preset time and count
- Output for HP printers
- 6-digit in-line readout
- 200 nsec pulse resolution
- Output for ratemeter

The Hewlett-Packard scaler-timers allow wide flexibility in nuclear counting applications. The HP 5201L Scaler-Timer has a single-channel pulse height analyzer that allows manual or automatic spectrometry. In manual operation, the two integral discriminators have a digital (voltage) readout, and the discriminator levels are stable to 0.01% per °C full scale. In automatic operation, the lower level discriminator may be scanned by application of an external voltage.

The HP 5201L and 5202L differ in that the pulse height analyzer in the 5201L is replaced by a simple integral discriminator in the 5202L. Both may be used to totalize counts, count for a preset time or register time for a preset number of counts to occur. They have selectable preset count times in integral multiples of 0.1 second or 0.1 minute and utilize the power line frequency as the time base. Sampling mode may be either automatic or manual. The HP 5203L Scaler may be either manually operated or externally gated. It may be slaved to a 5201L or a 5202L.

All of the scalars and the scaler-timers have the same input counting capability with multiple pulse resolution of 200 nsec. A binary-coded-decimal (BCD) output for driving HP digital recorders or other devices is provided in these instruments as a standard feature.

The compact modular cabinet design gives high portability, maximum utilization of space, plus the ability to convert quickly from bench to 19" rack mounting configuration (all conversion hardware included at no extra cost).

### Specifications, 5201L

#### General

- Resolving time:** preset time mode, 200 nsec; preset count mode 10  $\mu$ sec.
- Maximum periodic count rate:** preset time mode,  $5 \times 10^4$  counts/sec; preset count mode,  $1 \times 10^9$  counts/sec.
- Preset count times:** 0.1 sec to 9,999.9 sec in 0.1 sec steps; 0.1 min to 9,999.9 min in 0.1 min steps.
- Sampling modes:** "AUTO" position allows repeat of count at sampling rate. Sample time is 200 msec plus count time. "MANUAL" position requires that "START" button be depressed to start sample.
- Accuracy:**  $\pm 1$  count = time base accuracy.
- Time base:** power line frequency (typically  $\pm 0.1\%$  or better. 100 kHz crystal time base optional).
- Gate in:** gate opens with external dc level  $> +5$  and  $< +20$  V. Gate closes with dc level  $< +2$  V.
- Gate out:**  $> +15$  V when gate open,  $< +2$  V when gate closed.
- Reset:** front panel pushbutton.
- Power:** 115 V or 230 V  $\pm 10\%$ , 60 Hz, 60 watts (50 Hz version optional).

Temperature range:  $-0^\circ\text{C}$  to  $+55^\circ\text{C}$ .

+20 V power supply: output through rear TNC.

#### Pulse height analyzer

**Modes of operation:** (a) integral; (b) differential with narrow window; and (c) differential with wide window.

**Input circuit:** ac coupled. Impedance 500 ohms. Maximum input pulse rise time is determined by 1 msec input time constant.

**Polarity:** positive or negative (selectable).

**Output:** nominal 0.5 V pulse into 50 ohms for rate meter input.

#### NaI (Tl) scintillation counting performance

**Discriminator ranges:**  $E_{min}$  and  $E_{max}$  are adjustable from 0.05 V to 5.0 V.\*

$\Delta E$  range: adjustable up to 0.5 V.\*

**Discriminator stability:**  $\pm 0.01\%$ /°C full scale ( $\pm 0.5$  mV/°C) change in  $E_{min}$  and  $E_{max}$ ; and less than  $\pm 0.1\%$ /°C of full scale ( $\pm 0.5$  mV/°C) change in  $\Delta E$  over 0 to  $+55^\circ\text{C}$  and with  $\pm 10\%$  line voltage variations.

**Integral linearity:**  $\pm 0.25\%$  of full scale.

#### 5 MHz scaler performance (Integral mode only)

**Multiple pulse resolution:** 200 nsec.

**Minimum pulse requirements:** 40 nsec minimum pulse width, 0.1 V peak.

#### Functions

**Preset time:** displays number of counts during preset time interval of 0.1 sec or 0.1 min,  $\times$  preset number N.

**Preset count:** displays number of 0.1 second or 0.1 minute intervals required for N counts to occur.

**Preset range:** "N" number selectable 1 to 99,999 on thumb-wheel switches.

**Manual:** counts from discriminator are totalized for (a) time between pushbutton START-STOP; or for (b) time duration of a dc level applied at rear connector. (See Gate In, above.)

### Specifications, 5202L

(same as 5201L, except as follows)

#### Discriminator

**Input pulse range:** 0.1 to 5.0 volts (max peak pulse amplitude).

**Level adjustment:** variable over small range around 80 millivolts (factory setting).

**Input circuit:** ac coupled. Impedance 1000 ohms. Maximum input pulse rise time is determined by 1 msec input time constant.

**Minimum pulse requirements:** 40 nsec minimum pulse width.

**Multiple pulse resolution:** 200 nsec.

### Specifications, 5203L

#### General

**Resolving time:** 200 nsec.

**Maximum periodic count rate:**  $5 \times 10^4$  counts/sec.

**Gate in:** gate opens with external dc level  $> +50$  V and  $< +20$  V. Gate closes with dc level  $< +2$  V.

**Gate out:**  $> 15$  V when gate is open,  $< +2$  V when gate is closed.

**Reset:** (a) front-panel pushbutton or (b) automatic internal reset.

\* $\Delta E$  is differential between  $E_{min}$  and  $E_{max}$ .  
 $E_{min}$  is level set by Lower Level Discriminator (LLD)  
 $E_{max}$  is level set by Upper Level Discriminator (ULD)

Power: 115 or 230 volts  $\pm 10\%$ , 50 to 60 Hz, 45 watts

+20 V power supply: output at rear TNC.

Discriminators: same as 5202L.

#### Functions

Check: totalize internal source of approx. 80 kHz when START button is depressed.

### Specifications, all models

#### Printer output

Output: 4-line BCD (1-2-4-8) code, "1" state negative standard; (1-2-4-8 code, "1" state positive or 1-2-2-4 code, "1" state positive optional).

Impedance: 100 k ohms each line.

Positive state level: +18 volts.

Negative state level: -8 volts.

Reference levels: +17.6 V, 350-ohms source impedance.

-6.9 V, 1000-ohm source impedance.

Print command: +28 volt step, from 2700 ohms in series with 470 pF.

Hold-off requirements: externally applied +5 V to -6 V.

Printer output connector: 50-pin Amphenol 57-30500, rear.

#### Physical

Registration: 6 long-life rectangular digital display tubes with display storage.

Dimensions: 16 $\frac{3}{4}$ " wide, 3-15/32" high, 11 $\frac{1}{4}$ " deep (426 x 88,2 x 286 mm).

Weight: 18 lbs (8,2 kg) net; 23 lbs (10,4 kg) shipping.

Accessories furnished (5201L, 5202L and 5203L): two HP 10519A Cables, 6' long, BNC connectors; circuit board extenders; detachable power cord.

Prices: 5201L, \$1950; 5202L, \$1400; 5203L, \$950.

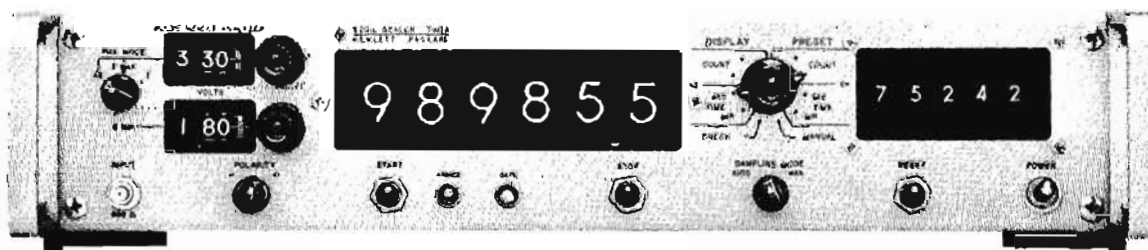

5201L



5202L



5203L

**NUCLEAR**

## SCINTILLATION DETECTORS

Premium resolution, stability with low drift  
10600A Series

### Advantages:

- Low drift characteristics
- Premium resolution and stability
- Built-in high gain amplifier
- Completely sealed

Hewlett-Packard scintillation detectors utilize selected sodium iodide (thallium activated) crystals and photomultiplier tubes as integral assemblies. These assemblies combine efficient scintillators for gamma ray detection with photomultipliers having the best light collection characteristics. A solid-state amplifier, with sufficient gain and pulse shaping characteristics to directly drive a single channel analyzer without a linear amplifier, completes the scintillation detector.

The HP scintillation detectors are available in both solid and well configurations, with 2 x 2 and 3 x 3 NaI (TI) crystals. A magnetic shield is utilized in all detectors, which maximizes protection from external ac and dc magnetic fields. The entire assembly is sealed against moisture in a stainless steel case. A TNC connector is used for the low-voltage power supply input, a high-voltage BNC connector is used for the high-voltage power supply input, and a BNC connector for the signal output. A focus control and three-position selector switch (for selecting: long time constant; short time constant, X1 gain; short time constant, X10 gain) are accessible on the detector assembly for optimizing measurements.

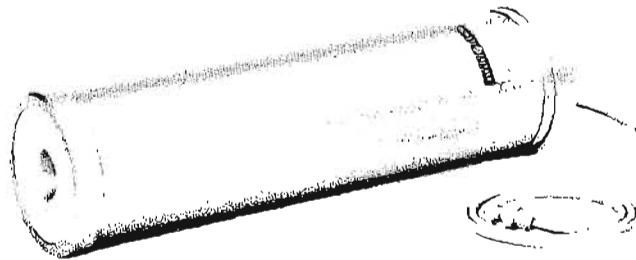

Typical Detector

### Specifications

#### All Models

**Crystal:** NaI (TI).

#### Typical output:

- Long Time Constant (LTC) 0.30 V/MEV.
- Short Time Constant, Gain 10: 1.8 V/MEV.
- Short Time Constant, Gain 100: 18 V/MEV.
- (Detector at 25°C, High Voltage 1000 V.)

#### Magnetic field effects:

- AC:** < ±0.5% change in pulse height (2 gauss rms).
- < ±0.1% change in resolution (2 gauss rms) 60 Hz.
- DC:** < ±0.5% change in pulse height (±2 gauss field).

#### Amplifier

- High voltage input:** 2000 V (max.), 7.35 meg $\Omega$  (approx.).
- Low voltage input:** +20 V at 21 mA (+25 V max. input).

#### Typical output pulse shape @ 25°C:

- LTC:** 0.25  $\mu$ sec rise time-constant, 12.5  $\mu$ sec fall time-constant, 30  $\mu$ sec fall time, peak to 0 volts.
- Gain: X10** 0.25  $\mu$ sec rise time-constant, 1  $\mu$ sec fall time-constant, 3  $\mu$ sec fall time, peak to 0 volts.
- Gain: X100** 0.25  $\mu$ sec rise time-constant, 1  $\mu$ sec fall time-constant, 3  $\mu$ sec fall time, peak to 0 volts.

#### Maximum no load output:

- LTC ±4 volts
- X10 ±10 volts
- X100 ±10 volts

**Output impedance:** 50 $\Omega$  nominal.

#### Physical

**Focus control:** to adjust photomultiplier tube for optimum gain and resolution.

#### Connectors:

- Low voltage:** TNC connector (female).
- High voltage:** high voltage BNC connector (female).
- Signal output:** BNC connector (female).

#### Gain switch: 3-Position Slide Switch:

- LTC:** Long Time Constant.
- X10:** Short Time Constant, Gain 10.
- X100:** Short Time Constant, Gain 100.

**Magnetic shield:** internal between integral assembly and case.

**Case:** stainless steel, moisture proof.

**Accessories furnished:** one HP 10517A cable 6' long, TNC connectors.



### Specifications Individual

Model Type	10601A	10602A	10611A	10612A	10613A	10614A
Crystal Type	Solid		Well Type			
Crystal Dimensions	2" dia x 2" long	3" dia x 3" long	2" dia x 2" long	3" dia x 3" long	2" dia x 2" long	3" dia x 3" long
Well Dimensions			1" dia x 1-35/64" deep (25,4 x 39,3 mm)	21/32" dia x 2" deep (16,7 x 50,8 mm)	21/32" dia x 1-35/64" deep (16,7 x 39,3 mm)	1.024" dia x 2-3/64" deep (26 x 51 mm)
Resolution	< 8% FWHM*		< 10% FWHM*			
Drift	< = 2%**	< = 1%**	< = 2%**	< = 1%**	< = 2%**	< = 1%**
Stability	< = 2%***	< = 1%***	< = 2%***	< = 1%***	< = 2%***	< = 1%***
Overall Dimensions	2 3/4" dia x 12 1/4" long (70 x 312 mm)	3 1/2" dia x 13 3/4" long (82 x 350 mm)	2 3/4" dia x 12 3/4" long (70 x 324 mm)	3 1/2" dia x 13 3/4" long (82 x 350 mm)	2 3/4" dia x 12 3/4" long (70 x 324 mm)	3 1/2" dia x 13 3/4" long (82 x 350 mm)
Crystal Window	0.015" Aluminum	0.019" Aluminum	0.010" Aluminum			
Weight: Net Shipping	5 lbs (2,3 kg) 12 lbs (5,4 kg)	8 lbs (3,6 kg) 15 lbs (6,8 kg)	5 lbs (2,3 kg) 12 lbs (5,4 kg)	8 lbs (3,6 kg) 15 lbs (6,8 kg)	5 lbs (2,3 kg) 12 lbs (5,4 kg)	8 lbs (3,6 kg) 15 lbs (6,8 kg)
Price	\$835	\$1475	\$885	\$1565	\$885	\$1565

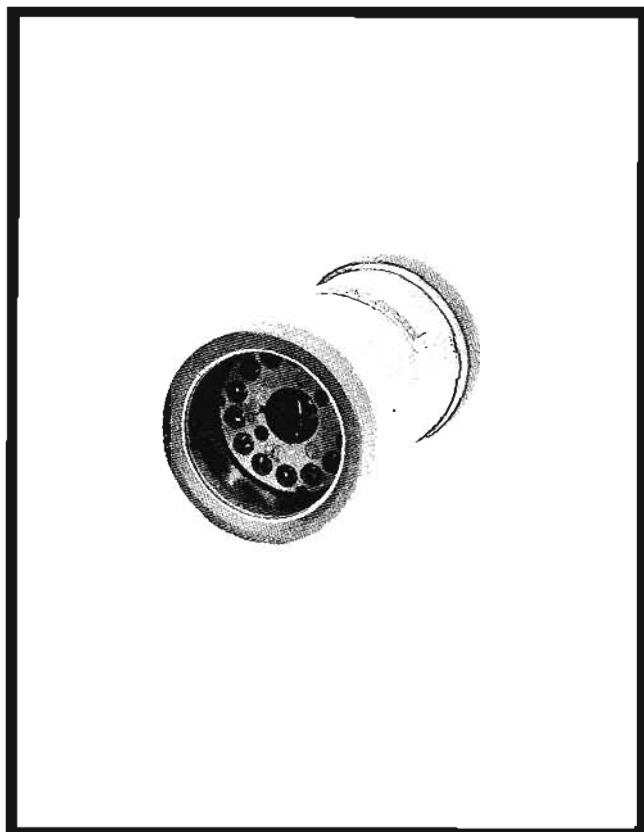

The HP Model 10615A contains the excellent preamplifier and amplifier used in HP Scintillation Detectors. Special-purpose, high-performance detectors can be quickly assembled by plugging a suitable 10-stage photomultiplier tube and phosphor assembly into the recessed socket of the 10615A. The unit is compatible with HP Scalers and High Voltage Supplies. Dimensions: 2.95 in. (75 mm) diameter, 6.25 in. (158 mm) long. Price, \$295.

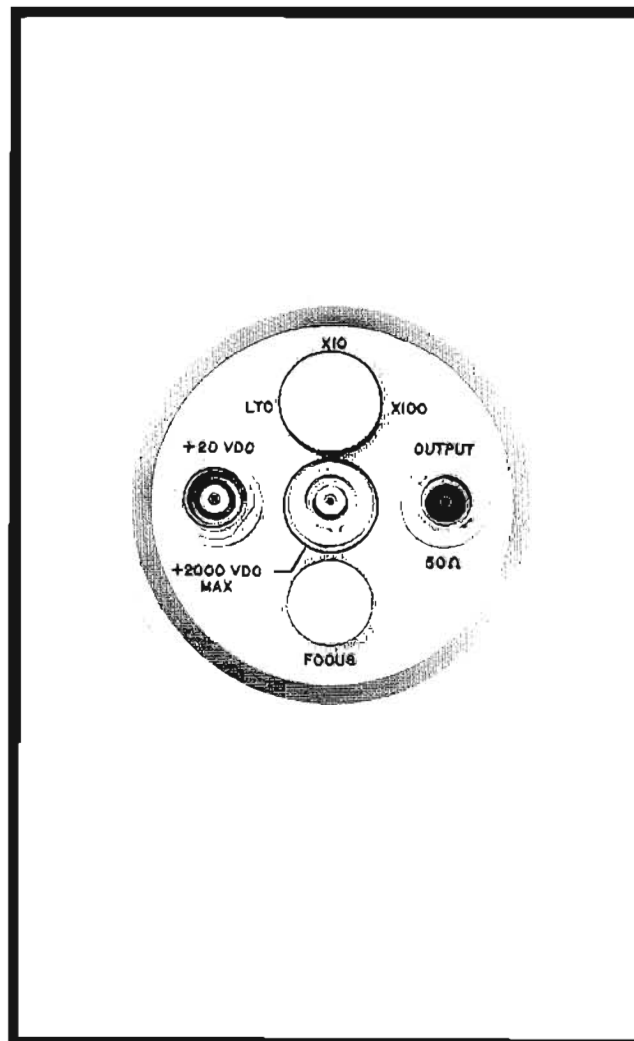

Connection and Switch Position View for HP 10600A Series Scintillation Detectors and for HP 10615A Preamplifier.

# NUCLEAR



## POWER SUPPLY; LEAD SHIELD

Highly stable, convenient HV power supply

Models 5551A, 10650A

### 5551A Power Supply

The Hewlett-Packard Model 5551A High-Voltage Power Supply is designed to supply the high voltage (170 V to 1615 V requirements of the photomultiplier in a gamma scintillation detector assembly. High stability and broad voltage range (voltage ranges are overlapped with an accurate vernier adjustment) make this instrument valuable in numerous other experimental and laboratory applications.

The 5551A utilizes standard components operating well within their design range. This, coupled with conservative overall design means long, trouble-free operation, plus ease of maintenance. Safety design features minimize inadvertent contact with high voltages.

Model 551A is an ideal instrument for applications where high stability with low current and high voltages is required.

This instrument is packaged in Hewlett-Packard's modular cabinet, allowing quick and easy conversion from bench to 19" rack configuration.

### Specifications, 5551A

#### Electrical

**Output voltage:** 170 V to 1615 V.

**Polarity:** positive or negative (selectable).

**Output current:** 1 mA max.

**Output impedance:** < 20 K.

**Line regulation:**  $\pm 0.01\%$  for  $\pm 10\%$  line change.

**Ripple:** < 0.005% rms or 15 mV (whichever is larger).

**Power:** 115 or 230 volts  $\pm 10\%$ , 60 Hz, 50 watts (50 Hz version available upon request, no charge).

#### Physical

**Weight:** net 20 lbs (9.1 kg); shipping 25 lbs (11.3 kg).

**Dimensions:** 16 $\frac{3}{4}$ " wide, 3-3/16" high, 11 $\frac{1}{4}$ " deep (426 x 97 x 286 mm).

**Connectors:** high voltage BNC connector, rear. Stabilizer input telephone jack, rear (mating connector, 2-conductor, 1251-0067; Switchcraft, Inc. 280). Can accept voltage from an external stabilization system (normally in the range 0  $\pm 100$  volts).

**Accessories furnished:** one HP 10516A high-voltage cable, 6 ft. long, high-voltage BNC connectors; detachable power cable.

**Price:** \$350.

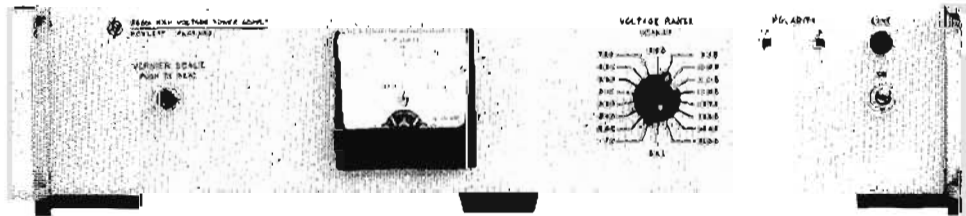

5551A HV power supply

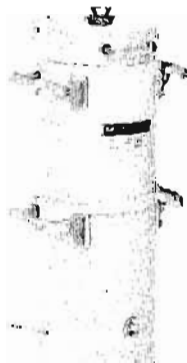

10650A

### 10650A lead shield

The HP Model 10650A provides the equivalent of 2-inch lead shielding in all directions to lower background count with the 10611A and 10613A well-type scintillation detectors. Low porosity virgin lead is used with a brass outer case and stainless steel inner liner. The counter-balanced lid has hole sizes of  $\frac{3}{8}$  in. (16 mm) and  $\frac{1}{8}$  in. (28 mm) for introducing test tube or solid samples. A lever permits raising the detector during removal. Maximum weight is 375 lbs. The shield is in two sections for easy handling. Dimensions: 7 $\frac{1}{2}$  in. (190 mm) diameter, 18 $\frac{3}{4}$  in. (475 mm) long. Price, \$455.

# PHYSICAL MEASUREMENT

## Introduction



# TEMPERATURE, PHYSICAL MEASUREMENTS

The measurement of temperature, strain, pressure, force, torque, displacement, acceleration, and many other physical effects involves all of the elements discussed below.

**Measurand**, the structure or medium that is subjected to or transmits the physical effects to a transducer.

**Transducer**, translates the physical effect to an electrical signal, or signal change, with or without the aid of excitation power from the signal conditioner.

**Signal conditioner**, provides the power and auxiliary controls that are needed to obtain a voltage output, which is a known function of the transducer-sensed effect, that is suitable for measurement and recording.

**Recorder**. The transducer signal becomes useful only when it has been recorded in a form suitable for evaluation. The two basic forms of recording are analog recording, usually done on a strip chart recorder, and digital recording. Digital recording involves digitizing the transducer signal and recording it in computer compatible format on punched cards, punched paper tape, or magnetic tape. The 2010, 2013, 2015, and 2017 Digital Data Acquisition Systems (pages 84, 86, 87, 92) are digital recorders.

### Temperature transducers

The most commonly used temperature transducers are thermocouples, resistance thermometers, and thermistors, in that order.

The thermocouple is a junction of two dissimilar conductors. Heating of the junction causes a small voltage to be developed across it, as a function of temperature. This thermally generated voltage is the thermocouple output. The resistance thermometer is basically a resistive element made of a pure metal, usually nickel, platinum or copper. Resistivity of the sensing element increases with temperature. Thermistors are solid semiconductors, usually consisting of fused metal oxides, carbon, or other compounds, that decrease in resistance with increased temperature. Thermocouples offer the advantages of low cost and operation over wide temperature ranges (up to 1000°C spread for some thermocouple junctions). Resistance thermometers are more costly than thermocouples, but offer far greater accuracy and resolution, as well as operation over wider temperature ranges (platinum

sensing elements are accurate from -200 to +1000°C). Though the negative resistance-temperature coefficient of thermistors is about ten times the positive coefficient of resistance thermometers, thermistors are much less accurate and are useful only over a small temperature range because of their very non-linear response to temperature. The resistance variation, with temperature, of resistance thermometers and thermistors can be converted to output voltage by using dc signal conditioning, discussed later.

### Quartz thermometry

Quartz thermometry is an entirely different temperature measurement technique. The transducer is a small disc of quartz that operates, within a protective probe housing, as a piezoelectric resonator for a sensor oscillator. The resonant frequency of the quartz crystal varies with heating or cooling of the probe such that the frequency of the sensor oscillator output signal is a linear function of temperature. The sensor oscillator is incorporated into a complete measurement system that includes a reference oscillator and a mixer. The reference frequency is mixed with the sensor oscillator frequency to cancel frequency offset. The mixer output is summed by counters that display the sensed temperature as a direct digital readout in °C or °F. The counters also provide a bcd output for recording temperature readings in computer compatible format.

Over the range of -80 to +250°C (-112 to +482°F) the quartz thermometry technique pioneered by Hewlett-Packard offers simple operation combined with measurement resolution to 0.0001°. A variety of temperature sensing probes are available, and are capable of withstanding high pressures. The standard probes may be connected to the sensor oscillator through up to 1000 feet of coaxial cable, and may be operated up to one mile away with the addition of accessory amplifiers. A special oceanographic probe, available for temperature measurement at depths to 22,000 feet, incorporates sensor and reference oscillators and the mixer in one high pressure housing.

### Strain gage transducers

The strain gage is a resistance element, usually metallic, that changes resistance when it is strained, or deformed as a result of being stressed. The basic application of the strain gage is stress measure-

ment, in which strain gages are bonded (or otherwise suitably coupled) to a specimen that is to be stress-tested. The strains that develop in the specimen during stress testing are transmitted to the strain gages, causing them to change resistance.

Just as important as stress measurement are other applications of the strain gage technique. In these applications, strain gages coupled to carefully designed and calibrated response elements are used to measure pressure, force, torque, and other physical effects that are convertible to strain. Strain gage resistance changes can be converted to output voltage by using dc signal conditioning.

### DC signal conditioning

The most basic signal conditioning requirement of thermoresistive and strain gage transducers is excitation power, to convert their changes of resistance to a voltage output. The excitation is usually connected across a bridge circuit, in which the transducer forms one, two or four active arms. Bridge completion resistors must be provided when a transducer forms only one or two active arms of the bridge.

Other signal conditioning requirements are a bridge balance adjustment potentiometer and provision for single or double shunt calibration, in which calibration resistors shunted across one or opposite arms of the bridge simulate the resistance change that would be caused by a specific magnitude of physical effect sensed by the transducer. With the calibration circuits activated, the excitation level is set to calibrate the output signal level to be produced by sensing of the actual effect. Finally, the signal conditioning may provide output attenuation, which is used to "normalize" the output signal to simplify system setup.

The 2480 Series Signal Conditioning Equipment described on page 562 not only meets all of the signal conditioning requirements, but sets performance standards and offers convenience features that are completely unique. Now data system users can get every item needed for most physical measurements (except transducers) from Hewlett-Packard. The advantages are obvious: single source procurement, superior performance throughout the physical measurement system, and high-quality dependable equipment backed world-wide by Hewlett-Packard service facilities.



# QUARTZ THERMOMETER

0.0001°C or °F resolution, direct measurement  
2800A/2801A

The method of temperature sensing employed in the 2800A/2801A Quartz Thermometers is based on the sensitivity of the resonant frequency of a quartz crystal to temperature change.

Temperature range of the 2800A/2801A Quartz Thermometers is  $-80$  to  $+250^{\circ}\text{C}$  ( $-112$  to  $+482^{\circ}\text{F}$ ). The quartz thermometer is considerably more linear than a platinum resistance thermometer:  $\pm .05\%$  of span from  $-40$  to  $+250^{\circ}\text{C}$  compared with a typical figure of  $\pm .55\%$  for the same range for platinum thermometers. Linearity of the quartz thermometer is superior to that of thermocouples and thermistors, which have an exponential characteristic. The excellent sensing characteristics of the quartz thermometer are supplemented by the advantages of direct digital readout (no bridge balancing, or reference to resistance or voltage-temperature tables or curves), immunity to noise and cable resistance effects, no reference junction, and good interchangeability between sensing probes.

The 2800A is equipped with one probe, measures over a fixed sample time and provides a 4-digit readout and recording output. Resolution is  $0.1^{\circ}\text{C}$  or  $^{\circ}\text{F}$  (optionally  $0.01^{\circ}$ ).

The 2801A is equipped with two sensing probes for measuring temperature at either probe or the difference between the two. A 6-digit visual readout and recording output with a choice of push-button-controlled sample times provides resolution of 0.01, 0.001 or  $0.0001^{\circ}\text{C}$  or  $^{\circ}\text{F}$ . Signal polarity indication is provided. The 2801A includes the capability for operation as a 300 kHz electronic counter.

## Temperature sensing probes

Various standard probe configurations are available for the 2800A/2801A Quartz Thermometers. Probes from the 2850 series are furnished with the quartz thermometer. Outline drawings for all models appear at right.

## Remote operation of probes

Each temperature sensing probe has a quartz-crystal which is resonant at a frequency dependent upon temperature, and is driven by a 2830A Sensor Oscillator. The oscillator is a transistorized device enclosed in a small die-cast aluminum housing. They are normally installed in the 2800A/2801A flush-mounted in a front panel recess. A 12-foot cable connects each probe to its associated sensor probe; this cable forms part of the tuned circuit and cannot be altered in length. However, the sensor oscillators may be unplugged from the instrument and connected to it by standard 75-ohm coaxial cable up to 1000 feet in length, with no loss in measurement accuracy.

A special probe configuration has been designed for oceanographic temperature measurements. The 2832A Temperature Sensor Assembly combines a sensor crystal, reference crystal, oscillator, and mixer circuits within a cylindrical aluminum pressure case.

The 2832A can be submerged in the deepest portions of the ocean (around 36,000 feet) without special cables or booster amplifiers.

## Multi-channel applications

Temperatures sensed by up to 10 probes can be conveniently measured on a 2800A/2801A Quartz Thermometer with the addition of a 2840A Sensor Selector (described in a separate data sheet). The 2840A has front panel recesses (similar to those on the quartz thermometer) for 10 sensor oscillators. Automatic sequential measurements of up to 60 probes is possible with a 2918A Thermometer Scanner, in conjunction with a 2800A/2801A Quartz Thermometer.

Applications of the Quartz Thermometer to the Chemical Industry. The 2801A Quartz Thermometer, with its direct, precise digital readout and recorder output for example, permits convenient measurement of freezing point depression or boiling point elevation of a solution. From this the molecular weight of the solute can be calculated. Use of the quartz thermometer in this manner is described in Application Note 78-2, available from Hewlett-Packard on request.

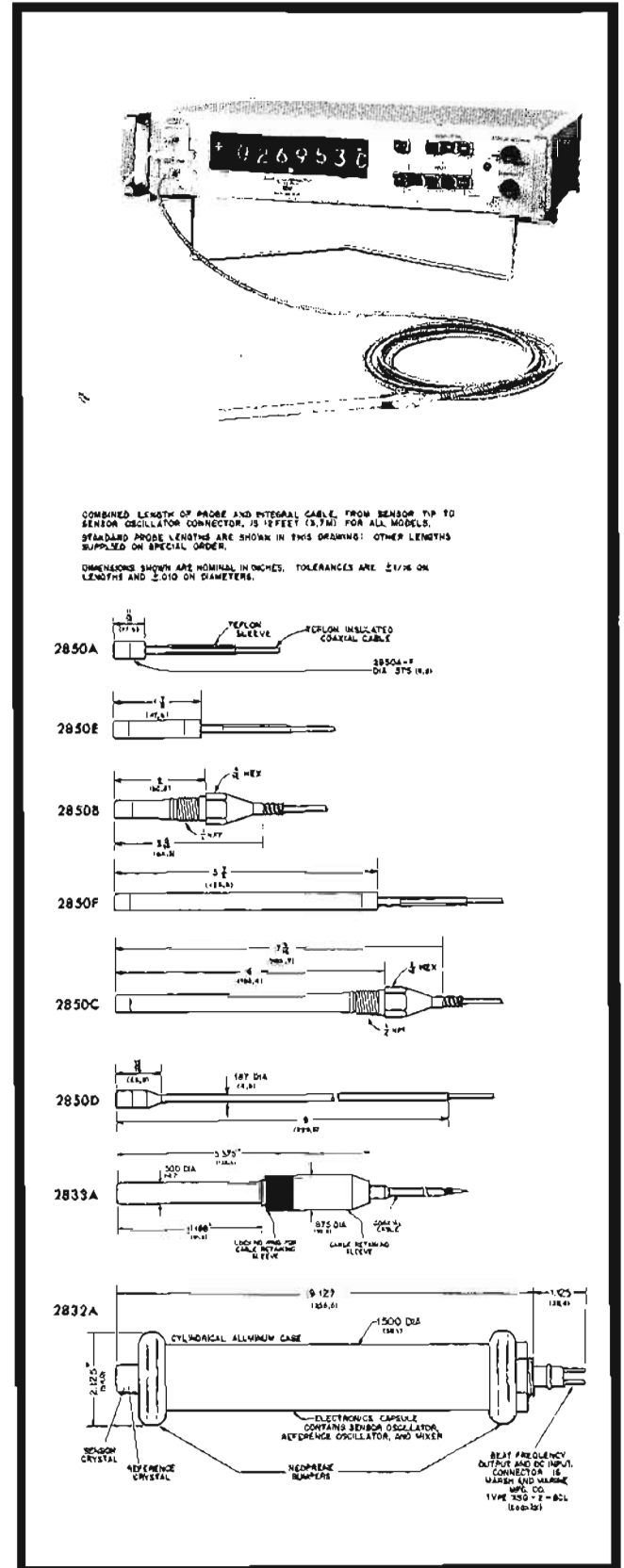

# QUARTZ THERMOMETER

0.0001°C or °F resolution, direct measurement  
2800A/2801A



## TEMPERATURE

### Specifications 2800A and 2801A

**Temperature range:** -80 to +250°C (-112 to -482°F with Option M1).

**Calibration accuracy:** thermometer-probe combination calibrated at factory to within .02°C (.04°F) absolute, traceable to NBS.

**Linearity:** -40 to +250°C. Better than .15°C (.27°F) referred to best fit straight line through 0°C; -80 to 0°C. Better than .05°C (.09°F) referred to same line as above; 0 to +100°C. Better than .05°C (.09°F) referred to best fit straight line through 0°C.

**Stability:**

**Short term:** short term stability of 2800A is better than  $\pm .01^\circ\text{C}$ , and 2801A is better than  $\pm .0001^\circ\text{C}$ .

**Long term:** zero drift less than  $\pm .01^\circ\text{C}$  (.018°F) at constant probe temperature for 30 days.

**Ambient temperature effect:**

2800A: less than .01°C over ambient range (0 to +55°C);  
2801A: less than .001°C per °C change in ambient.

**Display:**

2800A: 4-digit in-line readout in °C, or °F. Decimal point and °C (°F) indication included; 2801A: 6-digit in-line readout in C<sup>2</sup>, or °F. Decimal point, °C (°F), and polarity indication included. Readout and units indication in ke in counter mode of operation. Storage feature holds display between readings.

**Digital recorder output:** BCD, 4-2<sup>2</sup>-2-1, positive-true, for each displayed digit, decimal point (exponent), polarity, and operating mode.

**External programming:**

**Measurement initiation:** circuit closure to ground. Probe selection and resolution (2810A only): T1, T2, or T1-T2 and .01, .001, or .0001° resolution selected by external circuit closures to ground.

**Counter operation:**

**Model 2801A only:** Frequency Range: 2 Hz to 300 kHz; Resolution: 10, 1, and 0.1 Hz; Sensitivity: 0.5 to 10 V rms; Input Impedance: 1M, 50 pF shunt; Gate Time (sample period): 0.1, 1 and 10 sec.

**Power required:** 2800A: 115/230 V  $\pm 10\%$ , 50 to 60 Hz, 65 W;  
2801A: 115/230 V  $\pm 10\%$ , 50 to 60 Hz, 85 W.

**Instrument environment:** ambient temperatures from 0 to +55°C (+32 to +130°F), at relative humidity to 95% at 40°C.

**Weight:** 2800A net 20.5 lb (9.2 kg), shipping 33 lb (15.0 kg);  
2801A net 22.5 lb (10.1 kg), shipping 35 lb (15.9 kg).

**Dimensions:** 3-15/32" x 16-5/16" x 19" (88 x 414 x 483 mm).

**Price:** Model 2800A Quartz Thermometer, including one 2830 Sensor Oscillator and one 2850 series Temperature Sensor, \$2,250; Model 2801A Quartz Thermometer, including two 2830 Sensor Oscillators and two (matched) 2850 series Temperature Sensors, \$3,250.

### Specifications 2831A amplifier

**Gain:** 40 dB approx. from 28 to 29 MHz.

**Power required:** +12 to +20 V dc, at 8 mA approx.

**Operating conditions:** -20 to +70°C (-4 to +158°F). Case is sealed and may be totally immersed (to depth of 1 or 2 feet) in nonreactive fluids.

**Dimensions:** overall length (including connectors) 4 inches (102 mm) approx. Width is 1-3/16 x 1-3/16 inch (30 x 30 mm).

**Weight:** net wt 4 oz (110 gm); ship wt 8 oz (230 gm).

**Price:** Model 2831A Oscillator Amplifier, \$100.00.

### Specifications 2832A oceanographic sensor

**Temperature range:**

**Calibrated range:** -2 to +40°C (+28 to +104°F).

**Resolution:** .001°C (.0018°F) corresponds to 1 Hz (nominal) change in output frequency.

**Linearity:** within  $\pm .02^\circ\text{C}$  of best straight line from -2 to +40°C passing through 0°C.

**Stability:**

**Short term:** jitter is less than  $50 \times 10^{-6}^\circ\text{C}$  (.05 millidegree) with 2832A Assembly completely immersed in environment.

**Long term:** drift is less than  $\pm .01^\circ\text{C}$  per month.

**Response time:** response to abrupt change in temperature of water flowing past sensor at 2 fps: 63.2% of final value in 3 seconds; 99.0% of final value in 16 seconds; 99.9% of final value in 24 seconds.

**Output signal:** 1000 Hz (nominal,  $\pm 20$  Hz) per °C; Zero frequency output at 0°C is standard. Optional outputs available on request.

**Level:** 0.2 V rms minimum into 100 ohms.

**Power required:** +12 to +15 V dc, at 25 mA maximum supplied from external source.

**Power supply sensitivity:** output frequency changes less than 1 Hz for 1 V dc change in supply voltage.

**Pressure case rating:** 10,000 psi (equivalent to ocean depth of 22,500 feet).

**Weight:** net 1 lb 6 oz (0.62 kg); shipping 4 lb (1.8 kg).

**Price:** Model 2832A Temperature Sensor Assembly, \$1,950.00.

### Specifications 2833A temperature sensor

**Temperature range:** -80 to +125°C (-112 to +257°F).

**Response time:** response to abrupt change in temperature of water flowing past sensor at 2 fps: 63.2% of final value in 3 seconds; 99.0% of final value in 16 seconds; 99.9% of final value in 24 seconds.

**Output signal:**

**Frequency:** 28.2 MHz nominal at 0°C. 0.25 V rms approx.

**Power required:** +12 to +15 V dc, at 10 mA approx.

**Pressure case rating:** 10,000 psi (equivalent to ocean depth of 22,500 feet).

**Weight:** net wt 8 oz (227 gm); ship wt 2 lb (0.9 kg).

**Price:** Model 2833A Temperature Sensor Assembly, \$750.00.



## SIGNAL CONDITIONING UNITS

### Compact conditioners for resistive transducers

#### 2480 Series

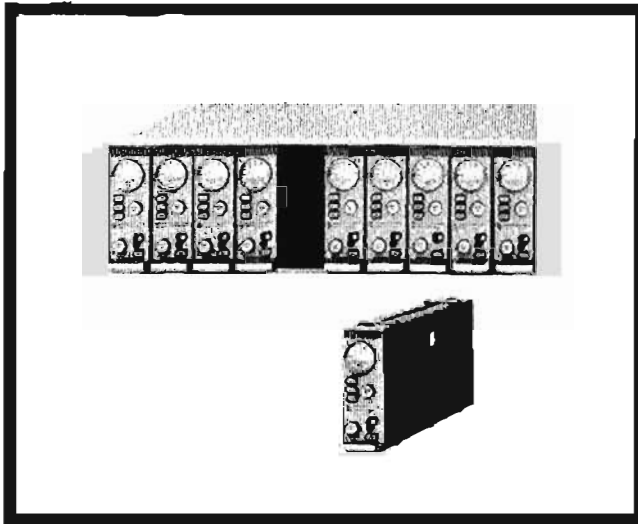

The 2480 Series of Signal Conditioning Modules provide the necessary dc excitation and signal conditioning (operating, balancing and calibrating components) for strain gage transducers, resistance temperature bulbs, and other types of resistive transducers.

The following units are available:

- 2480A DC Excitation Source
- 2481A Resistance Bridge
- 2482N Monitor Function Selector
- 2480K Excitation Coupler
- 12521A Combining Case

Operating, balancing and calibrating components and control circuitry for 1, 2, or 4-active arm transducers are provided by the 2481A Resistance Bridge. This unit can be installed together with a 2480A DC Excitation Source in a single, compact instrument case, illustrated above. This arrangement provides each transducer channel with its own independent power supply, which may be operated either in a constant voltage or constant current mode, simply by setting a switch. The excitation source also has a novel "Linear" mode (switch-selectable) providing exceptional linearity for single active arm bridges.

An alternate arrangement, in which many transducer channels can be excited by one external power supply, is obtained with a 2480K Excitation Coupler in each single conditioning module in place of the 2480A DC Excitation Source. Local control of excitation level, with switch-selectable constant voltage or constant current operation, is available as a standard option for the 2480K Excitation Coupler. A system employing one power supply for a number of transducers can be converted at any time to a power supply-per-channel arrangement, because the 2480K Excitation Coupler and 2480A DC Excitation Source modules are interchangeable, and the 2481A Resistance Bridge can simply be unplugged from one module and plugged into the other.

Housed in a similar signal conditioning module, the 2482N Monitor Function Selector enables excitation voltage or current, or transducer signal voltage, to be selected for monitoring by an external voltmeter.

Installed in an optional combining case, ten signal conditioning modules can be rack-mounted side by side, using only 3/4" of vertical rack space.

### 2480 Specifications

**Constant voltage mode:** output 0.1 to 30 V dc, continuously adjustable; (0 to 200 mA).

**Noise output:** the total noise output due to ripple, and thermal noise is 220  $\mu$ V max. and 177  $\mu$ V min.

**Regulation:** load regulation: change in output voltage for load current change of 200 mA is <600  $\mu$ V at 30 V output; line regulation: change in output voltage for  $\pm 10\%$  line voltage change is <600  $\mu$ V at 30 V output.

**Constant current mode:** output compliance: 0 to 24 V (0 to 200 mA).

**Noise output:** total noise output due to ripple, and thermal noise is 3.6  $\mu$ A max. and 3.0  $\mu$ A min.

**Regulation:** load regulation: change in output current for resistive load change from 0 to 3 k ohms is <10  $\mu$ A at 200 mA output; line regulation: change in output current for  $\pm 10\%$  line voltage change is <10  $\mu$ A at 200 mA output, reducing to 3  $\mu$ A at 1 mA output.

**Linear mode:** (this mode of operation is suitable for bridge configuration with 3 arms fixed and 1 arm variable).

**Excitation voltage:** voltage across bridge 0.1 to 30 V.

**Noise output:** the total rms noise due to ripple, injected current and thermal noise is 3.6  $\mu$ A max. and 3.0  $\mu$ A min.

**Regulation:** load regulation: change in current through bridge sensing arm, as variable arm is changed through permissible range is <10  $\mu$ A at 200 mA; line regulation: change in current through bridge sensing arm for  $\pm 10\%$  line voltage change is <10  $\mu$ A at 200 mA.

### General specifications

**Environmental conditions:** ambient temperature: operating: 0 to +55°C; non-operation: -40 to +75°C; relative humidity: operating non-operating: to 95%, +25 to +40°C.

**Power required:** 115/230 V  $\pm 10\%$ , 50 to 400 Hz. Power consumption approximately 8.5 W at full load.

**DC Isolation:** 10<sup>10</sup> ohms minimum for sense leads, excitation leads or signal leads to ground or ac line.

**Guard:** capacitance (guard shield connected): capacitance between circuitry within guard shield and ac power line or ground, 10 pF max.; breakdown: guard shield to ac power line or ground, 500 V dc minimum.

**Price:** Model 2480A DC Excitation Source (installed in combining case) and 2481A Resistance Bridge, approx. \$555 per channel. Individually: 2480A Excitation Source, \$245; 2480K Excitation Coupler, \$35; 2481A Resistance Bridge, \$65; 2482N Monitor Function Selector, \$125; 12521A Combining Case, \$500.

## ULTRASONIC SPEEDS MAINTENANCE, MINIMIZES DOWN TIME



## LEAK, FRICTION DETECTORS

Delcon Ultrasonic Translator detectors are the first lightweight, low cost devices to provide instantaneous translation of ultrasonic energy to the audible range. Since their introduction in early 1961, their applications have spread from their initial use of maintaining pressure systems to utilization on vacuum systems, locating high-voltage breakdown and electrical corona, troubleshooting operating fluid power systems, pinpointing engine defects, making possible preventive maintenance, analysis of engines and motors, and other industrial uses.

In the Delcon Ultrasonic Translator detector a transducer pickup in the probe responds primarily to a 36 to 44 kHz bandwidth—the bandwidth of pronounced intensity in all mechanical and electrical phenomena tested to date. Since we are not interested in sounds in the audio frequency range, the output of the transducer is subjected to a band pass filter which effectively removes all sounds below 15 kHz. We are then free to convert the ultrasonic noises which occur between 36 kHz and 44 kHz; we hereodyne this band of frequencies with an oscillator having a frequency of 40 kHz. By proper sideband selection and filtering, our study band becomes a new group of frequencies between 30 Hz and 5 kHz within our peak hearing range. The relative timbre of sounds is preserved so that it is possible to analyze the amplitude and characteristics of the received ultrasonic signals.

Unlike other ultrasonic test equipment, these portable devices are passive; they are responsive to ultrasonic energy produced by external forces. The flow of air molecules escaping from a leak in a pressure system releases ultrasonic energy as the higher velocity molecules collide with those in the atmosphere. Bearings emit ultrasonic energy in proportion to their wear. Fluid power systems at work emit ultrasonic energy.

The Delcon principle of ultrasonic detection and translation employs two interchangeable transducers—the 22 degree directional probe for ultrasonic energy transmitted through the atmosphere, and the contact probe for ultrasonic energy conducted through solids. The diagrams on this page indicate the versatility of both industrial and scientific applications.

### Pressure and vacuum leak detection

The sonic energy produced by the turbulence that occurs in the transition from

laminar to turbulent flow of a gas provides a detectable and measurable quantity that makes practical the use of this fundamental property of gases for leak detection and location. Figure 1 illustrates these conditions in a simple way. The ultrasonic method of leak detection depends upon these conditions being fulfilled at least in part. As with other natural phenomena, sharp lines of demarcation are difficult to establish; however,



ORIFICE LEAK  
Figure 1

experience has shown that orifice-type leaks are easily detected at distances up to and beyond 100 feet. Diffused or labyrinth-type leaks do not generate the required turbulence conditions and consequently are not readily detected ultra-

sonically: Figure 2 shows what is meant by a labyrinth-type leak.

### Locating high pressure leaks

As can be seen from Tables 1 and 2, there are compelling monetary reasons for maintaining the integrity of pressure distribution systems. Of course, leakage in poisonous, noxious or explosive gas systems is motivation itself for immediate location and repair.

Ultrasonic leak detection units have



Figure 2

been employed with considerable success for several years in the maintenance of wide variety of gas pressure systems. This section contains general recommendations for the use of ultrasonic leak detection in high pressure systems and some suggestions in specific applications.

Table 1

AIR PRESSURE (PSI)	HOLE SIZE (inches in diameter)			
	.016	.032	.063	.125
30	2.00	9.00	35.00	140.00
100	11.00	44.00	175.00	700.00
300	44.00	175.00	700.00	2800.00
1000	220.00	875.00	3500.00	14000.00

### ANNUAL COST OF ELECTRICITY TO MAINTAIN ONE LEAK IN A COMPRESSED AIR SYSTEM (electricity rates \$ .02/KWH)

Table 2

DETECTION DISTANCE (feet)	HYDROGEN 4.00/c	HELIUM 14.00/c	NITROGEN 2.80/c	OXYGEN 2.60/c	ACETYLENE 4.00/c
1	21.00	73.50	14.00	13.50	27.00
3	63.00	220.00	44.00	41.00	82.00
10	210.00	730.00	140.00	135.00	270.00
30	630.00	2200.00	440.00	410.00	820.00
100	2100.00	7300.00	1400.00	1350.00	2700.00

### ANNUAL COST OF SUPPLYING ONE LEAK FROM COMPRESSED GAS CYLINDERS





The Contact Probe was developed one year after the Ultrasonic Translator detector. Previous field usage with the airborne probe had indicated the feasibility of detecting ultrasonic energy occurring within metallic structures. However, the airborne probe is unable to detect this energy unless the metallic surface is light enough to be oscillated mechanically by the acoustic energy. Thin-wall tubing or sheet metal structures are typical ex-

amples. Heavier metallic structures such as cast fluid power components and generally all engine structures such as heads and bearing housings readily conduct ultrasonic acoustic energy. However, the mass of the structure prohibits its reverberating sufficiently to rebroadcast the acoustic energy through the atmosphere.

The ability to hear a distant train by putting your ear to the railroad track provides a good analogy of the conductance

of metallic mass. In this case, your ear is acting as a 'contact probe'. This very phenomenon proves valuable in the practice of ultrasonic detection. Since the Contact Probe cannot respond to acoustic energy of any level transmitted through the atmosphere, its detection is limited strictly to ultrasonic energy released within the metal structure. For the maintenance engineer, this means his inspection is immediately pinpointed to his precise area of interest. Furthermore, this knowledge of the precise inspection point allows repetitive, comparative inspections. (See Fig. 1). Fig. 2 portrays a typical example of the utilization of the Contact Probe.

### How the contact probe works

The 11-centimeter length of the stainless steel stylus of the Contact Probe was selected after extensive research by Delcon engineers and government research organizations. This precise length was selected both to provide access to hydraulic system components and also as a function of the wave length of a 40 kHz acoustic signal.

The Contact Probe stylus responds to the mechanical vibration conducted from the ultrasonic source through the structure. This mechanical energy is in turn transmitted through the stylus to a crystal within the probe housing. The crystal transducer converts the mechanical energy into an electrical signal. Solid-state circuitry within the probe amplifies the signal for introduction to the ultrasonic translation electronics within the basic instrument.

Currently ultrasonic detection using the contact probe is typically used in the fields of:

- 1) Fluid power systems
  - a) troubleshooting techniques
- 2) Engine maintenance
  - a) troubleshooting techniques
  - b) predictable maintenance programs with the use of auxiliary readout equipment
- 3) Locating high voltage breakdown not visually observed
- 4) Preventive maintenance and on the spot analysis of bearings and other components of rotating machinery
- 5) Friction analysis, strength of materials testing and other advanced applications.

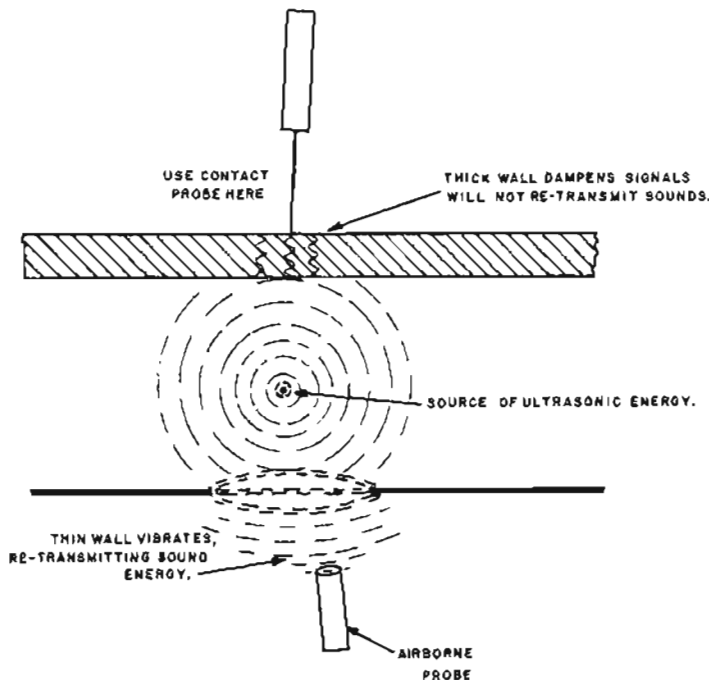

Figure 1.

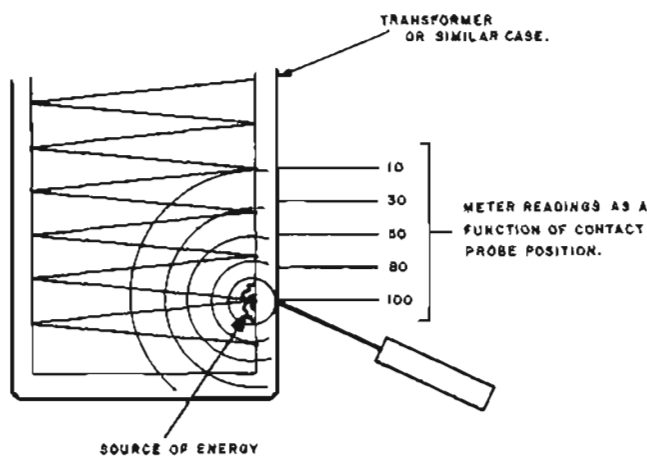

Figure 2.

# ULTRASONIC TRANSLATOR

Locates leaks or friction in seconds

Models 4917A, 4905A



## LEAK, FRICTION DETECTORS

### Ultrasonic translator detector Model 4905A

The 4917A is Underwriters' Laboratories, Inc. Listed, for use in Hazardous Locations Class I, Group D. This light-weight, portable instrument is designed for ultrasonic detection in laboratories, chemical plants, petroleum refineries, military installations and industrial facilities where intrinsically safe equipment is required or desirable.

Worn by a neck strap, the miniaturized 4917A is ideal for field use and in close quarters where maximum portability is desired.

**Construction:** rugged aluminum chassis and case; stainless steel hardware used throughout; Mil-Spec printed circuit board; quick-access battery compartment; detachable cabinet sideplates for servicing.

**Circuitry:** broad-range 4.5 volt transistorized circuit. Circuit gain controlled by single knob. Separate ON-OFF switch.

**Frequency response:** translates frequencies between 36 and 44 kHz into audible sounds; other sounds within audio range are screened out.

**Probe and coil cord:** hand-held; shielded against RF interference; output impedance 180 ohms; transistorized pre-amplifier; conical response  $\pm 11$  degrees at 3 dB points. Supplied with a six-foot coil cord employing latch-lock connectors. Less than 1 dB loss

### Ultrasonic translator detector Model 4905A

This lightweight, portable device is designed expressly for use in applications requiring a high degree of mobility. Offering operators hands-free efficiency, the 4905A has a built-in speaker making it ideal for hard-hat requirements. The reference meter is positioned on top of the instrument for easy viewing. The design of the 4905A is simple and functional. An untrained operator can use it efficiently after reading the detailed instructions on the cabinet. In addition, sturdy construction keeps the 4905A performing faithfully, year after year, despite very rough handling.

**Construction:** rugged aluminum chassis and case; stainless steel hardware throughout; Mil-Spec printed circuit board; quick access battery compartment; detachable cabinet sideplate for servicing.

**Circuitry:** broad-range 4.5 V transistorized circuitry with RF filter provides 100 dB dynamic range; circuit gain controlled by a single knob.

**Frequency response:** translates frequencies between 36 and 44 kHz into audible sounds; other sounds within audio range are screened out.

**Probe and coil cord:** hand-held; shielded against RF interference; output impedance 180 ohms; transistorized pre-amplifier; conical response  $\pm 11$  degrees at 3 dB points. Supplied with a six-foot coil cord employing latch-lock connectors. Less than 1 dB loss when used with a 100-foot connecting cable.

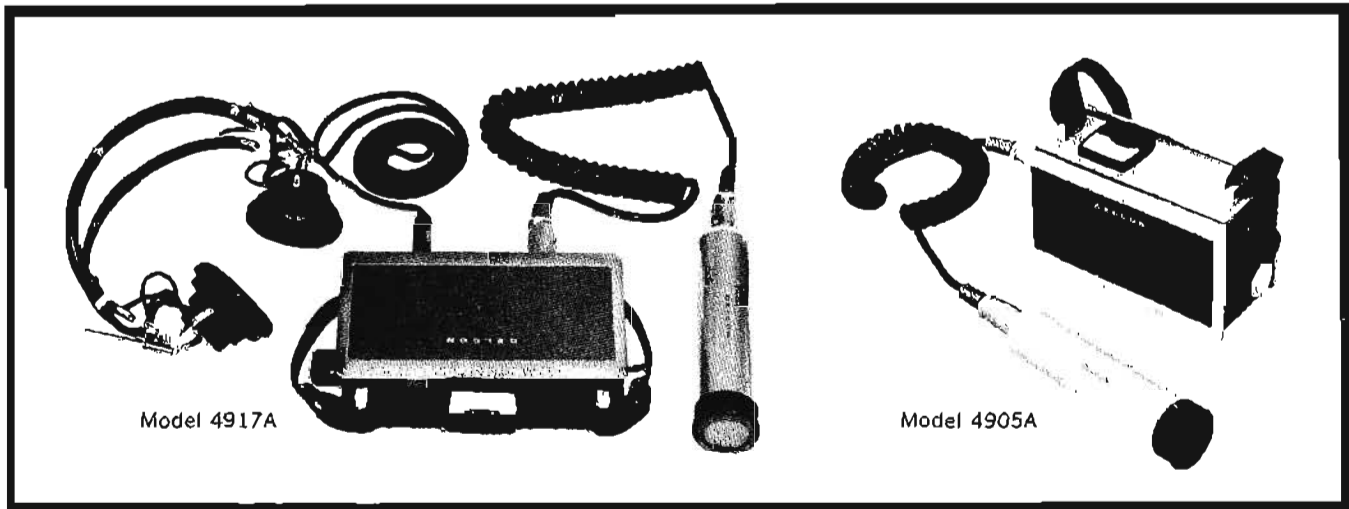

Model 4917A

Model 4905A

when used with a 100-foot connecting cable. Probe size:  $1\frac{3}{8}$ " diameter x  $6\frac{1}{4}$ " long, including protective monel-screened cap. Power to probe supplied through cord from main unit.

**Meter:** ultrasonic sound intensity measured by output meter; sealed and gasketed to lock out dirt and contaminants; scale length 1.75 inches; linear calibration (0-100) on upper scale for logging relative measurements; lower scale calibrated from 0-30 dB.

**Temperature range:** oscillator stability  $\pm 15$  Hz, and signal to noise ratio with  $\pm 1$  dB from 0-55 degrees C.

**Headset:** 10 milliwatts into 600 ohm matched headset. One volt RMS minimum.

**System weight:** 6 lbs (2.72 kg); shipping weight: 9 lbs (4.1 kg).

**Battery information:** three Eveready E-12 (Mercury type).

**Battery life:** 360-500 hours.

**Price:** Delcon 4917A, \$575.

Delcon 72007 Contact Probe available as optional accessory at \$150 additional.

**Probe size:**  $1\frac{3}{8}$ " diameter x  $6\frac{1}{4}$ " long, including protective monel-screened cap. Power to probe supplied through cord from main unit.

**Meter:** ultrasonic sound intensity measured by output meter; sealed and gasketed to lock out dirt and contaminants; scale length 1.75 inches; linear calibration (0-100) on upper scale for logging relative measurements; lower scale calibrated from 0-30 dB.

**Speaker:** incorporates 2.5 inch speaker; sealed against moisture; nominal power to speak 25 mW.

**Temperature range:** oscillator stability  $\pm 15$  Hz, and signal to noise ratio within  $\pm 1$  dB from 0-55 degrees C.

**Headset jack:** auxiliary 600 ohm output headset jack.

**System weight:** 6 lbs (2,7 kg); shipping weight: 8 lbs (3,6 kg).

**Battery information:** three Eveready E-12 or equivalent (Mercury type).

**Battery life:** 360-500 hours.

**Price:** Delcon 4905A, \$595.

Delcon 72007 Contact Probe is available as optional accessory. \$150

## LEAK, FRICTION DETECTORS



## ULTRASONIC TRANSLATOR

Rugged, battery-powered leak, friction detector  
Models 118, 4918A, accessories

### Ultrasonic translator detector model 4918A/118

The 4918A is Underwriters' Laboratories, Inc. Listed, for use in Hazardous Locations Class I, Group D. This lightweight, portable instrument is designed for ultrasonic detection in laboratories, chemical plants, petroleum refineries, military installations and industrial facilities where intrinsically safe equipment is required or desirable.

The instrument's laboratory performance and rugged construction coupled with convenient features such as the built-in loudspeaker and sound level meter makes the 4918A ideally suited for research and shop use as well as production testing applications.

The Model 118 is identical in design to 4918A except the latter does not have a recorder output jack, therefore the 118 is not listed for use in hazardous locations Class I, Group D.

### Model 72007 contact probe

#### Recommended uses:

- Locating internal hydraulic leakage
- Locating internal gas leakage within valves
- Detection of corona and arcing within transformers and sealed electrical components
- Inspection of bearings and mechanical devices

**Circuitry:** incorporates pre-amplifier circuit; output impedance 180 ohms; frequency response 36-44 kHz.

**Construction:** stainless steel transducer housing and sensing stylus.

**System weight:** net 17 oz (.46 kg); shipping 2 lbs (.91 kg).

**Price:** Delcon P/N 72007, \$150.

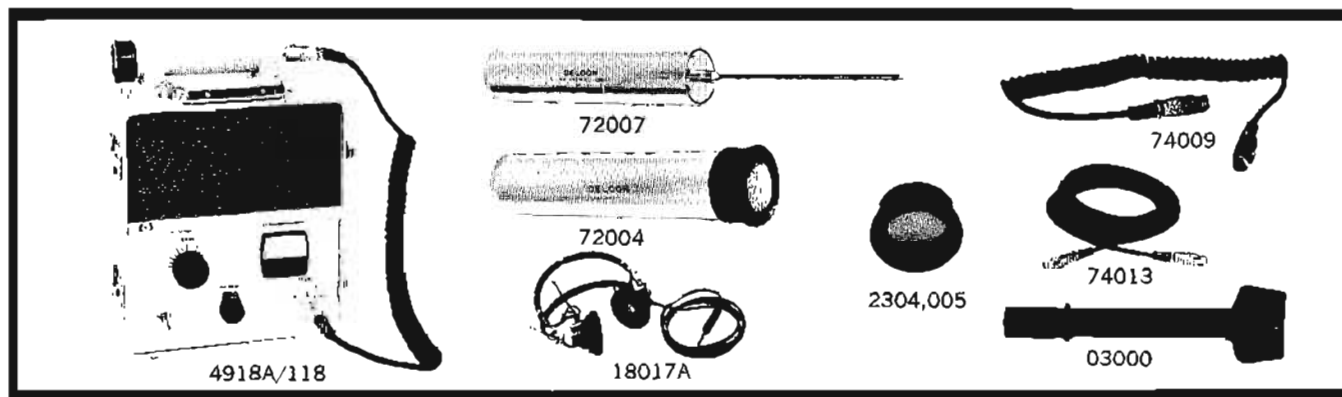

**Construction:** rugged aluminum chassis and cabinet with detachable front cover with operating instructions and accessory storage. Mil-Spec printed circuit boards; outside quick access battery compartment.

**Circuitry:** broad-range 4.5 volt transistorized circuitry with RF filter. Hermetically-sealed power switch.

**Frequency response:** translates frequencies between 36 and 44 kHz into audible sounds; other sounds within audio range are screened out.

**Probe and coil cord:** hand-held probe shielded against RF interference; output impedance 180 ohms; transistorized pre-amplifier; conical response  $\pm 11$  degrees at 3 dB points. Supplied with a six-foot coil cord employing latch-lock connectors. Less than  $1\frac{3}{8}$ " diameter x  $6\frac{1}{4}$ " long, including protective monel-screened cap. Power to probe supplied through cord from main unit.

**Meter:** ultrasonic sound intensity measured by output meter; sealed and gasketed to lock out dirt and contaminants; scale length 1.75 inches; linear calibration (0-100) on upper scale for logging relative measurements; lower scale calibrated from 0-30 dB.

**Speaker:** incorporates 4 x 6 inch speaker; power to speaker 400 mW.

**Temperature range:** oscillator stability  $\pm 15$  Hz, and signal to noise ratio within  $\pm 1$  dB from 0-55 degrees C.

**Headset jack:** auxiliary 600-ohm output headset jack. Headset furnished as standard.

**System weight:** net 11 lbs (5 kg); shipping 14 lbs (6.4 kg).

**Battery information:** three Eveready E-42 (mercury type).

**Battery life:** 500-700 hours.

**Price:** Delcon 4918A, \$850; Delcon 118, \$850.

Model 72007 Contact Probe available as optional accessory at \$150. additional.

### Accessories

#### Recommended uses:

- Locating gas pressure and vacuum leaks
- Locating corona sources
- Analyzing friction sounds

**Circuitry:** incorporates pre-amplifier circuit; output impedance 180 ohms; conical response  $\pm 11$  degrees at 3 dB points; frequency response 36-44 kHz.

**Construction:** non-ferrous construction. Mil-Spec printed circuit board.

**System weight:** net 11 oz (0.33 kg); shipping 2 lbs (0.91 kg).

**Price:** Delcon P/N 72004, \$150.

#### Other accessories:

18017A Headset, 600-ohm.

**System weight:** 1 lb (0.45 kg); shipping: 2 lbs (0.91 kg).

**Price:** \$27.50.

74009 Cord: Probe interconnecting, coiled, 6-foot.

**System weight:** 1 lb (0.45 kg); shipping: 2 lbs (0.91 kg).

**Price:** \$12.50.

74013 Cord: Probe interconnecting, 25 foot.

**System weight:** 1 lb (0.45 kg); shipping: 1 lb (0.45 kg).

**Price:** \$13.50.

03000 Focusing Extension for 72004 Probe.

**System weight:** 8 oz (0.23 kg); shipping: 1 lb (0.45 kg).

**Price:** \$3.00.

2304.005 Screened Cap for 72004 Probe.

**Shipping weight:** 1 lb (0.45 kg).

**Price:** \$3.00.

60007.10 Shoulder Strap (Installed at factory or shipped as kit) for Models 118 and 4918A.

**Shipping weight:** 1 lb (0.45 kg).

**Price:** \$10.00.

18019A Leather Utility Carrying Case.

**System weight:** 1 lb (0.45 kg); shipping: 4 lbs (1.82 kg).

**Price:** \$25.00.

# ULTRASONIC TRANSLATOR

Preset alarm and trigger circuit; ac powered  
Model 4950A



## LEAK, FRICTION DETECTORS

### Special features

- Precision signal attenuator consisting of a continuous attenuator and a 10 dB/step attenuator
- Selection of sample times from .1 sec to 3 sec
- Selection of relay on times from .1 sec to 3 sec
- Provision for integrating the signal to allow detection of signals in the presence of noise or to decrease the effect of fast transients
- Built-in loudspeaker
- Recorder output
- Oscilloscope output
- Operates from 115/230 V ac — 50/60 Hz power

### General

The Delcon 4950A Ultrasonic Translator is an instrument designed for production testing. It automatically detects ultrasonic energy in the 36 to 44 kHz range with sampling times as frequent as 150 per minute.

The solid-state device provides rapid assembly line quality control procedure in which the following typical defects are

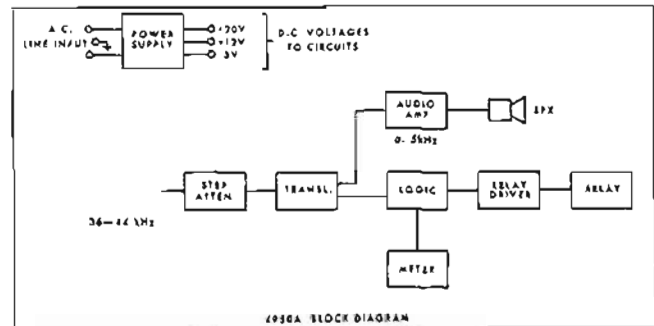

determined ultrasonically: leaks in pressure and vacuum systems and components; excessive friction in bearings and other close tolerance mechanisms; corona discharge and high voltage breakdown in transformers, capacitors and insulators.

The 4950A embodies alarm circuitry which actuates a relay whenever the intensity of the translated signal indicates trigger level on the front panel meter. By means of the built-in signal attenuator, the signal required to trigger the alarm can be set to any level in a 105 dB range above the instrument noise level.

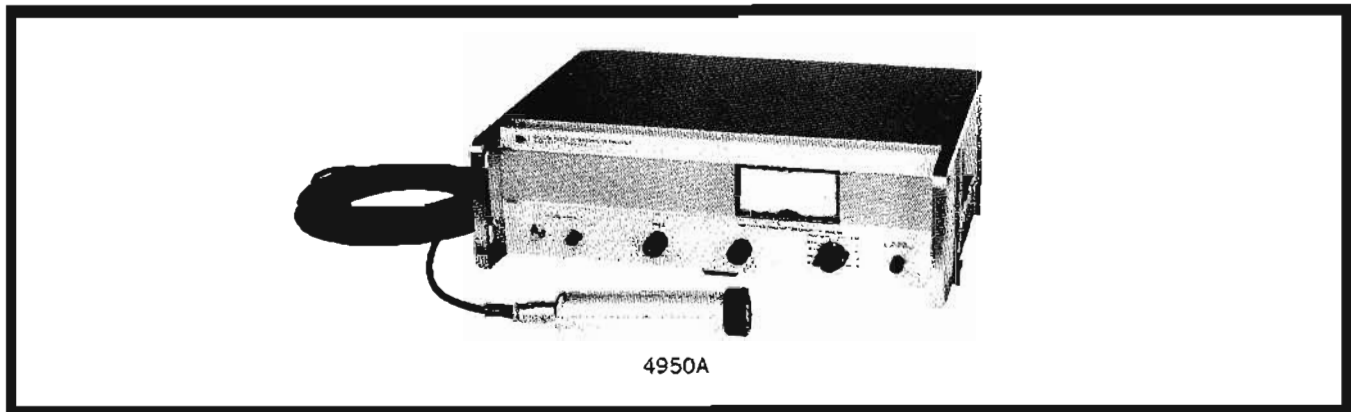

### Specifications

**Input:** uses Delcon wide range probes which respond to ultrasonic noises in the band of 36-44 kHz.

**Signal attenuator:** step /dB: 10 dB/step attenuator over 90 dB range. Accuracy  $\pm 1/2$  dB/step. Fine: Continuously adjustable over a range of 20 dB.

**Gate modes:** continuous: instrument operates as a normal ultrasonic detector. Whenever the signal exceeds the trigger level, the relay is actuated.

**Trigger:** instrument requires a trigger signal to open a gate in the meter circuit. The gate stays open for a preset gate time and then closes automatically. If the ultrasonic signal exceeds the trigger level while the gate is open, the relay is actuated. The required trigger signal is a momentary contact closure.

**Gate length:** length of gate can be preset to 0.1, 0.3, 1.0, or 3.0 seconds. (This also sets the integrating time in the integrate mode.)

**Non-integrate:** response of the instrument is directly proportional to the ultrasonic signal.

**Integrate:** response of the instrument is proportional to the integral of the ultrasonic signal.

**Alarm modes:** alarm length: Length of time the relay is actuated can be preset to 0.1, 0.3, 1.0 or 3.0 seconds.

**Non-latch:** relay is actuated whenever the signal is above the trigger level and drops out when the signal is below the trigger level. Hysteresis is approximately 2 dB.

**Latch:** relay is reset by pushing alarm light switch when signal level drops below trigger level.

**Audio:** has 2 watt audio amplifier, with a built-in loudspeaker.

**Auxiliary outputs:** oscilloscope: 1.0 V RMS output for full scale meter deflection. Recorder: 1.0 V dc output for full scale meter deflection. Phones: Internal loudspeaker is disabled when earphones are connected.

**Temperature:** operating temperature range 0-55 degrees C.

**Physical characteristics:** dimensions 16 $\frac{3}{4}$ " wide, 5 $\frac{1}{2}$ " high, 11 $\frac{1}{4}$ " deep. System Weight: 18 lbs (8.26 kg). Shipping Weight: 23 lbs (10.4 kg).

**Power:** 105 to 125 or 210 to 250 volts, 50 to 60 Hz, 15 watts.

**Price:** Delcon 4950A, \$1475.

## MODULAR ENCLOSURE SYSTEM

Versatile instrument packaging



Figure 1. Full rack width cabinets stack one atop the other.



Figure 2. Standard configurations include cabinets one-third and one-half full rack width. Accessory handle 11057A is shown on half-width instrument.

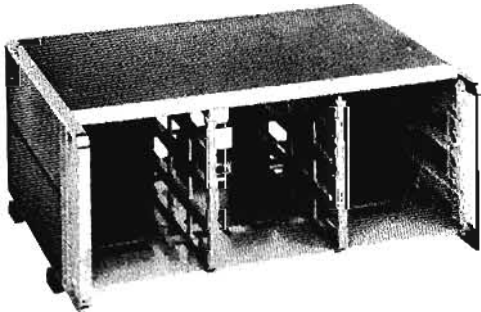

Figure 3. HP 1051A Combining Case.

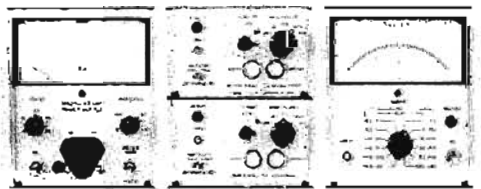

Figure 4. Here one HP instrument, one Harrison Division Instrument and two Dymac Division Instruments are mounted in an HP rack adapter frame.

The Hewlett-Packard modular enclosure system provides a complete solution to instrument packaging and mounting problems. The system is in accord with EIA standard rack and panel dimensions, yet each enclosure is equally well suited to bench or field use.

The matching enclosures offer an enviable combination of economy, strength and appearance. They are rugged enough to meet many of the stringent military requirements and present a rich, professional appearance which enhances the value of the instrument.

### Two types of instruments

Basically, instruments enclosed in the modular system fall into two classes:

1. Those units which require the full EIA rack width. This class of instruments mounts directly in racks with the two brackets and filler-strip included with the instrument. Feet and tilt stand also are provided with full-module instruments for bench use, and the instruments can be stacked conveniently for maximum utilization of available space. For semi-permanent stacking, joining brackets are available which effectively combine two instruments into a single physical unit. Control panel covers are also available for these instruments to protect them when they are transported.
2. Those units which do not need the full rack width. These instruments are standardized at one-half or one-third the width of the full module. Because of their size, they are easily portable and can be used readily in the field, as well as on the bench. Accessory handles 11056A (one-third module) and 11057A (one-half module) are attached easily to these instruments for added handling convenience. In addition, adapter frames are available to mount these units in the standard EIA racks. The HP 1051A, 1052A Combining Cases also can be used for a multi-instrument package that is both portable and easily rack mounted with the hardware provided. Both combining cases and rack adapter frames use blank panels to fill areas not used by instruments and accept one-third width drawers for convenient storage of leads, probes, etc. Model 1052A Combining Cases also accept cooling kits to maintain proper ambient temperature.

Characteristic of both classes of modular instruments is ease of maintenance. Top and bottom covers, as well as side panels, are removable to provide access to all adjustments and test points within the instruments.

**Specifications**

**1051A Combining Case (see Figure 3)**

Accepts third- or half-module instruments up to 1 1/4" (286 mm) deep.

**Dimensions:** 16 3/4" wide, 7 1/4" high, 13 1/4" deep (425 x 185 x 337 mm); hardware furnished for conversion to rack mount 19" wide, 6-31/32" high, 11 1/4" deep behind panel (483 x 177 x 286 mm).

**Weight:** net 10 lbs (4,5 kg); shipping 14 lbs (6,3 kg).

**Price:** HP 1051A, \$110.

**1052A Combining Case (not shown)**

Accepts third- or half-module instruments up to 16 3/8" (416 mm) deep.

**Dimensions:** 16 3/4" wide, 7 1/4" high, 18 3/8" deep (425 x 185 x 467 mm); hardware furnished for conversion to rack mount 19" wide, 6-31/32" high, 16 3/8" deep behind panel (483 x 177 x 416 mm).

**Weight:** net 12 lbs (5,4 kg); shipping 17 lbs (7,7 kg).

**Price:** HP 1052A, \$120.

**Rack adapter frame (see Figure 4)**

5060-0797 adapter to rack mount third- and/or half-module instruments up to 6-3/32" high (155 mm), \$25.

5060-0808 adapter to rack mount third- and/or half-module instruments up to 3" high (75 mm), \$25.

**Modular enclosure accessories (see Figure 5)**

Part Number	Control panel covers EIA panel height		Price
	(in.)	(mm)	
5060-0826	3-15/32	88	\$22.50
5060-0827	5-7/32	133	\$25.00
5060-0828*	6-31/32	177	\$27.50
5060-0829	8-23/32	222	\$28.50
5060-0830	10-15/32	266	\$30.00
5060-0831	12-7/32	310	\$32.50

\* Also fits HP 1051A and 1052A.

**Joining brackets (see Figure 7)**

5060-0215 Joining Bracket Kit for semi-permanently joining any two full-module instruments 1 1/4" (286 mm) deep behind the front panel, \$20.

5060-0216 Joining Bracket Kit for semi-permanently joining any two full-module instruments 16 3/8" (416 mm) deep behind the front panel, \$25.

**Accessory handles (see Figure 2)**

11056A Handle for any one-third module instrument, \$5.

11057A Handle for any one-half module instrument, \$5.

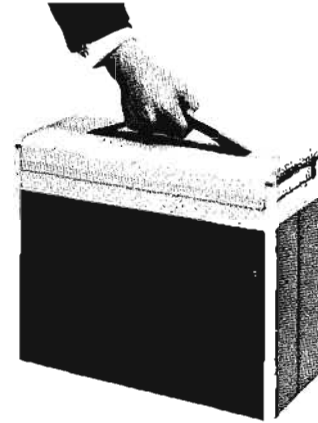

Figure 5. Instrument covers quickly convert full-width cabinets to easily carried portable units.

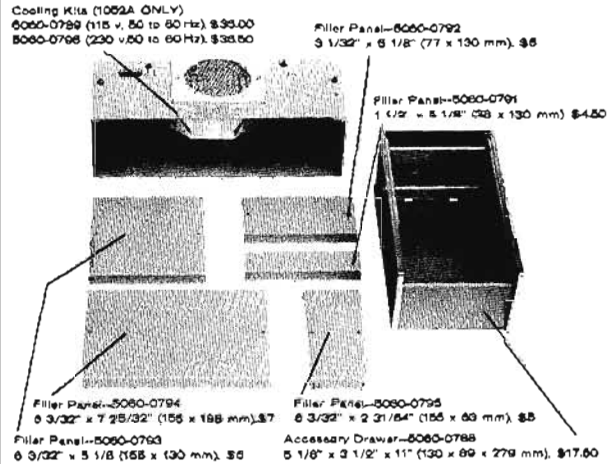

Figure 6. Combining case accessories.

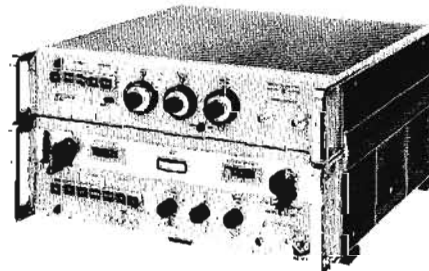

Figure 7. Joining brackets effectively weld instruments into a single physical unit.



# Indexes

Functional . . . . .	571
Model Numbers . . . . .	577
<b>Sales and Service Offices</b>	
Central and South America . . . . .	585
United States, Canada . . . . .	586
Europe . . . . .	588
Africa, Asia, Australia . . . . .	590





## FUNCTIONAL INDEX

- AC Clip-on Current Probe ..... 207
- AC Differential Voltmeter ..... 213
- AC Power Supply, Tape Recorder ..... 157
- AC Voltmeters ..... 188-199
- AC to DC Converters ..... 226, 230, 231, 234
- AC/DC Range Unit ..... 224
- AC-to-DC Converters ..... 226, 230, 231, 234
- AC/Ohms-to-DC Converter ..... 226, 230, 231
- Accessories
- Cable ..... 209, 462
  - Cart ..... 459
  - Chemical Instrumentation ..... 40, 41
  - Communication ..... 301
  - Electronic Counter ..... 508
  - Gas Chromatography ..... 116
  - Medical Instrumentation ..... 47, 57
  - Microwave ..... 279
  - Modular Enclosure ..... 568
  - Oscillator ..... 330
  - Oscilloscope ..... 462
  - Probe ..... 453
  - Recorder ..... 118, 119
  - Sampling Oscilloscope ..... 437, 440
  - Spectrum Analyzer ..... 396
  - Voltmeter ..... 207, 208
- Acoustic Stethoscope ..... 45
- Adapters
- BNC-to-Banana ..... 209, 462
  - BNC-to-Binding Post ..... 330
  - CATV 50 Ohm-to-75 Ohm ..... 443
  - Oscilloscope Camera ..... 461, 462
  - Oscilloscope, Vertical Test ..... 437
  - Rack, For Small Modular Instruments ..... 568, 569
  - Roll Chart ..... 118
  - Sweep, Slotted Line ..... 260, 261
  - Waveguide, Square-to-Round Flange ..... 271
  - Waveguide-to-Coaxial ..... 279
  - Waveguide-to-Waveguide ..... 279
  - X-Y-to-Strip-Chart Recorder ..... 118
- Adjustable Short, Waveguide ..... 278
- Aircraft Electronic Test Equipment ..... 356-358
- Ammeters ..... 200, 205-207, 223
- Amplifiers
- AC, Solid State ..... 409, 411, 412
  - Data ..... 404-406
  - DC ..... 493
  - Differential ..... 430, 431
  - Direct Writing Recorder ..... 136-141
  - Distributed, Wideband ..... 411
  - Fast-Pulse ..... 410, 411
  - Galvanometer Driver ..... 143
  - General-Purpose, Stabilized ..... 408, 409
  - Guarded Data ..... 403
  - Guarded Differential ..... 403, 430
  - Isolation ..... 408-412
  - Microwave ..... 414
  - Narrow-Band, DC ..... 406
  - Nuclear ..... 408, 409, 410, 556
  - Operational ..... 407, 408
  - Oscilloscope Plug-in ..... 429-431, 434, 436, 449, 450, 458
  - Power ..... 412, 413, 493
  - Precision (.01%) ..... 412
  - Pressure Ink System Recorder ..... 131-133, 136-141
  - Technical Information ..... 400-402
  - Transducers ..... 144, 145
  - Transducers, Medical ..... 60, 61
  - Video ..... 411, 412
  - Wideband ..... 409, 410, 411
- Analog Measuring Equipment
- Technical Information ..... 181-185
- Analog Voltmeters ..... 186-206
- Analyzers
- Carbon-Hydrogen-Nitrogen ..... 32, 33
  - Distortion and Waveform ..... 390-393
  - Network ..... 224-227
  - Noise ..... 290
  - Spectrum ..... 396-399
  - Technical Information ..... 387-389
- Antenna, Loop, VLF ..... 540
- Applanation Transducers ..... 60, 61
- ATC Transponder Test Set ..... 356, 357
- Atomic Frequency Standard ..... 534
- Atomic Frequency, Time Standard ..... 534
- Attenuator, Current-Controlled ..... 370, 371
- Attenuators
- Decade ..... 330
  - Fixed, Coaxial ..... 373
  - Pads, Coaxial ..... 373
  - Precision, Variable, Waveguide ..... 374
  - Variable, Coaxial ..... 166, 372
  - Variable, Waveguide ..... 374
- Audio Frequency Analyzers
- Distortion ..... 392, 393
  - Technical Information ..... 387, 388
  - Wave ..... 389, 390
- Audio Frequency Oscillators ..... 322-329
- Audio Frequency Signal Generators
- High Quality Audio Tests ..... 327
  - High Quality, High Accuracy Tests ..... 305, 307, 328, 329
  - Technical Information ..... 319-321
- Audio Signal Generator ..... 327
- Autovoltmeter ..... 203
- Auto-Ranging Voltmeter ..... 203, 225-227
- Auto-Viscometer ..... 38, 39
- Automatic Frequency Divider ..... 512
- Automatic Nulling Distortion Analyzer ..... 393
- Automatic Transfer Oscillator ..... 512
- Bandpass Filters, Coaxial ..... 272
- Battery-Operated Oscillator ..... 292, 324
- Battery-Operated Voltmeter ..... 195, 202, 290
- Bi-directional Counter ..... 520
- Blood Cell Counter ..... 45
- Blood Dilution Instrument ..... 45
- Blood Pressure Monitor ..... 51, 53, 58, 59
- BMR Instrument ..... 45
- Bolometer Mounts ..... 258, 379, 381
- Bridge, Universal ..... 250
- Cabinets, Modular ..... 568, 569
- Cable Testing ..... 300
- Cables, Test Leads ..... 47, 209, 462
- Calibrator, Peak Power ..... 382
- Calibrators
- Meter ..... 178, 179
  - AC/DC Meter ..... 168
  - Peak Power ..... 382
  - Power Meter ..... 380
  - Thermistor Mount ..... 380
  - Voltmeter ..... 179
- Calorimetric Power Meter ..... 383
- Cameras, Oscilloscope ..... 70-73, 460, 462
- Capacitive Voltage Dividers ..... 207
- Cardiac Monitoring Instruments ..... 48-51, 53-59
- Cardiac Output Computer ..... 58, 75
- Cardiac Resuscitation Instruments ..... 52, 57
- Carriages, Universal Probe ..... 260, 261
- Carts, Mobile for Medical Instruments ..... 47, 56, 57
- Cell Counter, Blood ..... 45
- Central Station Monitoring Instruments ..... 48, 53-56
- Cesium Beam Frequency Standard ..... 534
- Cesium Beam Time Standard ..... 536

# FUNCTIONAL INDEX



- Character Printer ..... 119  
 Chart Advance, X-Y Recorders ..... 118  
 Chronometer, Cesium ..... 536  
 Clamps, Waveguide ..... 279  
 Clip-on Current Meters ..... 206, 207  
 Clock ..... 98, 534, 536, 542  
 Clock, Atomic ..... 536  
 Clock, Precision ..... 536, 542  
 Clocks, Digital ..... 98, 542  
 Coaxial  
   Adapters-to-Waveguide ..... 251, 279  
   Attenuators ..... 372, 373  
   Bandpass Filters ..... 272  
   Connectors ..... 209  
   Detector ..... 273  
   Detector Mounts ..... 260, 261  
   Directional Couplers ..... 274, 275, 276  
   Directional Detectors ..... 274, 275  
   Frequency Meters ..... 530  
   Instrumentation ..... 264, 265  
   Low-Pass Filters ..... 266, 272  
   Pads ..... 373  
   PIN Modulators ..... 370, 371  
   Slide-Screw Tuner ..... 277  
   Slotted Sections ..... 260, 261  
   Terminations ..... 278  
   Thermistor Mount ..... 379-381  
 Coaxial, Adapter ..... 251  
 Comb Generator ..... 352, 369, 396  
 Combining Cases ..... 568  
 Communication Test Equipment ..... 280  
 Communications Systems Test Set ..... 288, 290, 292  
 Comparator, Frequency ..... 540  
 Comparator, Digital ..... 80-83  
 Comparator, VLF ..... 540  
 Computer, Cardiac Output ..... 58, 75  
 Computer, Instrumentation ..... 88-91  
 Converters  
   AC-to-DC ..... 224, 230, 234, 463-495  
   AC/Ohms-to-DC ..... 224, 230, 231  
   Digital-to-Analog ..... 98  
   Frequency ..... 355  
   Logarithmic ..... 117  
   Rise Time ..... 443  
   Voltage-to-Frequency ..... 235, 307  
 Cooling Kits ..... 568, 569  
 Counters  
   Blood Cell ..... 45  
   Electronic Instruments ..... 494-527  
 Couplers, Directional ..... 274-276  
 Coupling Transformer ..... 253  
 Crystal Detectors ..... 273  
 Crystal Filter, 2 MHz ..... 396  
 Current Probe ..... 206, 453  
 Data Amplifier ..... 404-406  
 Data Acquisition Systems ..... 80-92  
   Digital System Elements ..... 80-83  
   Technical Information ..... 78, 79  
 DC Ammeters ..... 200, 205, 206, 223  
 DC Amplifiers ..... 142, 403, 409, 412  
 DC Defibrillator ..... 52  
 DC Differential Voltmeter ..... 212, 213, 214  
 DC Milliammeter ..... 200, 205, 206, 223  
 DC Multi-Function Unit ..... 223  
 DC Null Meter ..... 186, 187  
 DC Power Supplies ..... 463-467  
 DC Standard ..... 174, 176  
 DC Transfer Standard ..... 173  
 DC Voltage Divider ..... 172  
 DC Voltmeters ..... 186, 187, 200-205, 212-228  
 Delay Generators, Digital ..... 314  
 Delay Generators, Oscilloscope Sweep ..... 433, 439, 451  
 Detectors  
   Coaxial ..... 260, 261  
   Crystal ..... 273  
   Directional ..... 274, 275  
   Null ..... 175, 186, 187  
   Scintillation ..... 556  
   Waveguide ..... 258  
 Differential Amplifiers ..... 403, 430, 431  
 Differential Voltmeters ..... 210-215  
 Digital  
   Clocks ..... 80-83, 93, 98  
   Converter ..... 80-83  
   Recorders ..... 93, 95, 96, 97  
   Voltmeters ..... 216-233  
 Digital Delay Generator ..... 314  
 Digital Voltmeter, Technical Information ..... 216, 218  
 Digital Voltmeter Plug-in ..... 220-224, 506  
 Digital-to-Analog Converter ..... 98  
 Diodes ..... 163-165  
 Direct Writing Electrocardiographs ..... 46  
 Direct Writing Medical Recorders ..... 50, 58, 59, 64-66  
 Direct Writing Systems ..... 120-130  
 Directional Couplers ..... 274-276  
 Directional Detectors ..... 274-275  
 Display Scanner, Oscilloscope ..... 452  
 Distortion Analyzers  
   Instruments ..... 293, 392, 393  
   Technical Information ..... 387, 388  
 DME/ATC Test Set ..... 356, 357  
 Doubler Sets, Frequency ..... 350  
 Down-Converter ..... 502  
 Driver, Synthesizer ..... 548  
 Dual-Directional Coupler ..... 274, 275  
 Dual-Pulse Unit ..... 314  
 Dual-Trigger Unit ..... 314  
 Dual-Beam Oscilloscope ..... 424, 425  
 Dual-Trace Amplifiers ..... 429, 436, 449  
 Dual-Trace Oscilloscope ..... 421  
 ECG Monitor ..... 50, 51, 54-56, 58, 59  
 ECG-EEG Amplifier ..... 51  
 ECG-EEG Monitor ..... 51  
 Electrocardiograph ..... 46, 50  
 Electrode Creme ..... 47  
 Electronic Counter ..... 494-527  
 Enclosures, Modular ..... 568, 569  
 Endless Loop Magnetic Tape Recorder, Medical ..... 68, 69  
 Extender, Oscilloscope Plug-in ..... 452  
 Fast-Pulse Amplifiers ..... 410, 411  
 Filler Panels ..... 568, 569  
 Filters, Low-Pass, Filter Kit ..... 528  
 Filters, Bandpass ..... 272  
 Filter, Crystal, 20 MHz ..... 396  
 Filter, Notch, 2 GHz ..... 396  
 Flexible Waveguide ..... 269, 270  
 Fluid Pressure Transducer ..... 57, 60  
 Flutter and Wow Discriminator ..... 528, 529  
 FM Discriminator ..... 528  
 FM-AM Signal Generator ..... 353  
 Force Transducers ..... 144, 145  
 Force Transducers, Medical ..... 60, 61  
 Frequency  
   Comb Generator ..... 396, 397  
   Converters ..... 502, 503  
   Comparator ..... 540  
   Counters ..... 494-527  
   Dividers and Clocks ..... 542  
   Doubler Probe ..... 340  
   Doubler Sets ..... 350

- Meters ..... 528-530  
 Response Test Set ..... 179, 351  
 Standards ..... 534, 538, 540  
 Synchronizer ..... 345  
 Synthesizer ..... 544, 546, 550  
 Technical Information ..... 494-497  
 Frequency Converter ..... 502, 506, 510, 512, 523  
 Frequency Divider, Automatic ..... 512  
 Frequency Divider, Clock ..... 542  
 Frequency Doubler ..... 352, 369  
 Frequency Doubler Probe ..... 340  
 Frequency Meter ..... 528, 529, 530  
 Frequency Response Test Set ..... 179  
 Frequency Standards, Variable ..... 544, 546, 550  
 Frequency Synthesizers ..... 544, 546, 550  
 Function Generator  
   Crystal Controlled ..... 305  
   Instruments ..... 305-309  
   Technical Information ..... 303, 304  
   Voltage Controlled ..... 307  
 G-band Instrumentation ..... 266  
 GAAS Infrared Sources ..... 168  
 Gamma Ray Detector ..... 556  
 Gamma Ray Spectrometer ..... 552, 553  
 Gas Chromatographs  
   Analytical ..... 18-26  
   Preparative ..... 27-30  
   Technical Information ..... 16, 17  
 Gas Pressure Transducers ..... 60-61, 144, 145  
 General Purpose Amplifiers ..... 143  
 Generators  
   Audio Signal ..... 322-329  
   Pulse ..... 310-316  
   SHF ..... 346-349  
   Signal, FM-AM ..... 353  
   Signal, Glide Slope ..... 358  
   Signal, High Frequency ..... 326-329, 334, 335  
   Signal, Low Frequency ..... 322-327  
   Signal, Power ..... 322, 323, 327  
   Signal, Phase ..... 305  
   Square Wave ..... 310-316  
   Sweep Delay ..... 308, 309, 310-316  
   Technical Information ..... 319-321  
   Telemetry ..... 354  
   UHF ..... 341-344  
   VHF ..... 336-339  
 Glide Slope Signal Generator ..... 358  
 Go-No-Go Programmer ..... 80-83  
 H-Band Instrumentation ..... 268  
 Harmonic Wave Analyzer ..... 294, 295, 390, 391  
 Heart Rate Monitor ..... 49, 50, 51, 75  
 Heart Sound Amplifier ..... 46, 74  
 Hemo Diluter ..... 45  
 Heterodyne Converter ..... 502, 523  
 High Conductance Diodes ..... 165  
 High Frequency Wave Analyzers ..... 294-295, 391  
 High Voltage Power Supply ..... 558  
 High-Power Waveguide Terminations ..... 297  
 Hot Carrier Commercial Diodes ..... 165  
 Hot Carrier Diodes ..... 164  
 ICU Monitors ..... 48-57  
 ILS Receiver Test Set ..... 358  
 Impedance  
   Bridge ..... 251  
   Meters ..... 242, 243  
   Technical Information ..... 236-239  
 Indicators, Standing Wave ..... 257, 258  
 Indicators, Noise ..... 290  
 Indicators, Null ..... 175, 186, 187  
 Inductance Meters ..... 242, 243, 251, 252, 254  
 Inductors, Reference ..... 253, 254  
 Infrared Sources ..... 168  
 Integrating Digital Voltmeter ..... 225, 226, 227  
 Integrating/Potentiometric Voltmeters ..... 228, 229, 232, 233  
 J-Band Instrumentation ..... 267  
 K-Band Instrumentation ..... 271  
 Keyboard, X-Y Recorder ..... 119  
 Kits  
   Accessory for 3406A ..... 199  
   Probe for 3406A ..... 199  
   Probe for 411A ..... 197  
 Klystron Power Supplies ..... 492  
 Large Aperture Current Probe ..... 206  
 Lead Shield ..... 558  
 Line Follower Systems ..... 119  
 Line Matching Transformer ..... 301, 330  
 Linear Motion Transducers ..... 144, 145  
 Linear Motion Transducers, Medical ..... 60, 61  
 Loads, Moving ..... 278  
 Logarithmic Converter ..... 117  
 Low Frequency Function Generator ..... 305-309  
 Low Frequency Oscillators ..... 305-308, 322-323  
 Low Power Waveguide Terminations ..... 278  
 Low-Pass Filters ..... 272  
 Magnetic Tape Systems ..... 150-154, 155-160  
 Magnetic Tape Systems, Medical ..... 68, 69  
 Magnetometer Probe ..... 206  
 Master Two-Step ..... 47  
 Medical Instrumentation ..... 45-75  
 Medical Recording Systems  
   Direct Writing Oscillographs ..... 46, 62-66  
   Magnetic Tape ..... 68, 69  
   Optical/Photographic Oscillographs ..... 66, 67  
   Ultraviolet Oscillographs ..... 67  
 Medical Technical Information ..... 44  
 Metabolism Tester ..... 45  
 Meters  
   AC-DC,  $\Delta$ VM, AC-DC VM, DC Standard ..... 176, 213  
   Ammeters ..... 200, 205, 206  
   DC  $\Delta$ VM, DC VM, DC Standard ..... 174, 212  
   Distortion ..... 392, 393  
   DB Level ..... 290  
   Frequency ..... 530  
   Kilovoltmeter ..... 186, 187, 200, 202-204  
   ..... 212, 213, 220, 228  
   Microvolt-Ammeter ..... 205  
   Milliammeter ..... 200, 205  
   Milliohm-meter ..... 202  
   Nanoammeter ..... 205  
   Noise ..... 290  
   Noise Figure ..... 384, 385  
   Null ..... 186, 187  
   Ohmmeters ..... 200-204, 223, 226, 230  
   Power ..... 375-383  
   Q ..... 252-254  
   Ratio ..... 214, 215, 259  
   RF Vector Impedance ..... 243  
   RX ..... 251  
   SWR ..... 257, 258  
   Vector Impedance ..... 242  
   Vector Voltmeter ..... 240, 241  
   Voltmeters ..... 186-233  
   Volt-ammeter ..... 186, 202, 205  
   Volt-ohmmeter ..... 200, 201, 203  
   Volt-ohm-ammeter ..... 200, 201, 204, 223  
 Microwave  
   Accessories ..... 279  
   Amplifiers ..... 414  
   Mixer Diodes ..... 164  
   Spectrometer ..... 31  
   Switches ..... 166  
 Microwave Frequency Converter ..... 502, 510, 511, 512  
 Microwave Power Measurements  
   Technical Information ..... 375-377  
 Microwave Test Sets ..... 351  
 Milliammeter, Clip-On DC ..... 206  
 Millivoltmeter, RF ..... 197-199  
 Mixer ..... 369, 511  
 Mixer, Harmonic ..... 265, 511  
 Modulators ..... 369-371  
 Modulators, PIN ..... 371  
 Monitors, Patient ..... 48-58  
 Monitor Scopes ..... 56  
 Motion Transducer ..... 144, 145  
 Motion Transducer, Medical ..... 60, 61

# FUNCTIONAL INDEX



Mounts, ECG Record	47
Moving Loads	278
Moving Short, Waveguide	278
Multi-Function Meters	200-202, 204, 223
Multi-Hole Couplers	276
Network Analyzer	244-247
Noise	
Figure Meter	384, 385
Meter	290
Sources	384, 385
Noise Figure Measurements	
Technical Information	384
Notch Filter 2 GHz	396
Nuclear Instrumentation	
Instruments	553-558
Technical Information	552
Null Detector	119
Null Meters, DC	186, 187, 212-215
Ohmmeters	200-204, 223, 226, 230
Optical Recorder	134, 135
Optical Recorder, Medical	66, 67
Opto-Electronic Devices	169
Oscillators	
Technical Information	319-321
Audio and Ultrasonic	305, 322-327
Crystal-Controlled	305
High Quality Audio Test	322-329
Portable	324
Quartz	538
Sinusoidal	306-309, 322-329
Sweep	361, 362-367
Technical Information	359, 360
Transfer	510
Ultra-Low Frequency	305-309
Voltage-Controlled	307
VHF	340
Wide-Range, Video Test	328
Oscillographs, Multi-Channel	134-143
Oscillographs, Multi-Channel, Medical	64-67
Oscilloscope Camera	70-73, 460-462
Oscilloscope Probes	453
Oscilloscope Testmobile Cart	458, 459
Oscilloscopes	
Instruments	297-299, 420-462
Medical	49, 54, 55, 56, 59
Technical Information	415-419
Osmometers	
Membrane	36, 37
Vapor Pressure	34, 35
P-Band Instrumentation	270
Pacemaker	51
Patch Panels	288, 289
Patient Monitoring	48-60
Patient Monitoring Systems	48-50
Patient Signal Selector	53
Peak Power Calibrator	382
Permapaper	120, 142, 452
Permapaper, Medical	47
Phase Measurement Plug-in	244-247, 523
Phase Measurements, Technical Information	236-239
Phase Meter	240-247
Phase Shifter	277, 305
Phonocardiograph	46, 74
Phosphor, Cathode Ray Tubes	419
Photo-Controlled Resistors (PCR)	167
Photomodulators	167
Photon Coupled Isolators	168
PIN Diodes	165
PIN Modulators	370, 371
PIN Photodiodes	168
Plethysmograph	57
Plotters, X-Y	99-108
Plug-in Digital Voltmeter	220
Plug-in Extender, Oscilloscope	452
Plug-in Function Generator	307
Portable Test Set	288-292
Portable Time Standard	536
Power Amplifier	413, 493
Power and Voltage Amplifiers	493
Power Meters	382
Power Supplies, Regulated DC	
Klystron	492
Scintillation Detector	558
Standby	537
Technical Information	468, 469
Preamplifiers, Medical	62, 63
Preamplifiers, Recording System	136-141
Preamplifiers, Scintillation	556
Precision Amplifier	403, 407, 412
Prescaler	502, 506
Preselector	399
Preset Counter	518
Preset Counting Plug-in	504
Pressure Transducers	144, 145
Pressure Transducers, Medical	60, 61
Primary Frequency Standard	534
Primary Standard	170, 171
Printer, Character	119
Printer, Digital	
Instruments	94-98
Technical Information	93
Probe Carriages, Universal	260, 261
Probe, Frequency Doubler	340
Probes	
Current	206, 453
Magnetometer	206
Microwave	260, 261
Oscilloscope	453
Quartz Thermometer	561
Voltmeter	207, 208
Programmer	447
Programmer Comparator	80-83
Programmable Frequency Standard	543-549
Programmable Oscilloscope	444
Pulse Amplifier	410, 411
Pulse Detector	369
Pulse Duration Unit	314
Pulse Generator	
Instruments	311-318
Technical Information	310
Pulse Height Analyzer	554
Pulse Modulator	369
Pulse Monitor	49-51, 75
Pushbutton Oscillator	326
Pushbutton Oscilloscope	444
Q Meters	
Instruments	252-254
Technical Information	248, 249
Q Standards	253
Quartz Oscillators	538, 539
Quartz Thermometers	560, 561
R-Band Instrumentation	271
Ratio Meters	214, 215, 259
Reaction Meter, Frequency	356
Receiver, Standard Frequency	540
Receiver, VLF Comparator	540
Recorder Accessories	118, 119
Recorders	
Digital	93-97
Direct Writing, Ink	120, 121, 131-133

- Direct Writing, Thermal . . . . . 120-130, 136-142  
 Direct Writing, Thermal, Medical . . . . . 62-66  
 Magnetic Tape . . . . . 150-160  
 Magnetic Tape, Medical . . . . . 68, 69  
 Optical . . . . . 134, 135  
 Optical, Medical . . . . . 66, 67  
 Oscilloscope Trace . . . . . 452  
 Strip-Chart . . . . . 109-116  
 Technical Information . . . . . 93, 99, 109, 146  
 Transducers . . . . . 144, 145  
 X-Y . . . . . 99-108  
 Redux Electrode Creme Paste . . . . . 47  
 Reference Inductors . . . . . 253, 254  
 Reflection Coefficient Measurement  
   Technical Information . . . . . 255, 256  
 Reflectometer, Time Domain . . . . . 442  
 Regulated Power Supplies . . . . . 463, 493, 537, 558  
 Resistance Standards . . . . . 172  
 Resistive Voltage Divider . . . . . 440  
 Resistors, Shunt . . . . . 208  
 Respiration Rate Monitor . . . . . 49  
 Reversible Counter . . . . . 520  
 RF Millivoltmeter . . . . . 197-199, 240-241  
 RF Test Sets . . . . . 351  
 RF Vector Impedance Meter . . . . . 243  
 RF Voltmeter . . . . . 197-199  
 RMS Voltmeter . . . . . 196  
 Roll Chart Adapter . . . . . 118  
 RX Meter . . . . . 251  
 S-Band Instrumentation . . . . . 266  
 Sampling Oscilloscope . . . . . 424, 427, 434-440  
 Sampling RF Voltmeter . . . . . 198, 199  
 Sawtooth Generators . . . . . 308  
 Scales . . . . . 554  
 Scanner, Digital . . . . . 80-83  
 Scanner, Oscilloscope Display . . . . . 452  
 Scintillation Detector . . . . . 556  
 Scintillation Detector Power Supply . . . . . 558  
 Scintillation Detector Preamplifier . . . . . 556  
 Shield, Lead . . . . . 558  
 Shorting Switch, Waveguide . . . . . 279  
 Shorts, Waveguide, Adjustable . . . . . 278  
 Shunt Resistors . . . . . 208  
 Signal Delay, ECG Recording . . . . . 50  
 Signal Generator Power Amplifier . . . . . 413  
 Signal Generators  
   Aircraft Test . . . . . 356-358  
   AM-FM . . . . . 353  
   Audio-Frequency . . . . . 322-329  
   HF . . . . . 328, 334-335  
   SHF . . . . . 346-349  
   Synchronizer . . . . . 338-339  
   Technical Information . . . . . 319-321  
   Telemetry . . . . . 354  
   UHF . . . . . 341-344  
   VHF . . . . . 336-340  
 Signal Sources . . . . . 303-367  
 Slide-Screw Tuners . . . . . 277  
 Slotted Line Measurements, Technical Information . . . . . 255, 256  
 Slotted Line Sweep Adapter . . . . . 260, 261  
 SPDT Microwave Switch . . . . . 166  
 Spectrometer, Microwave . . . . . 31  
 Spectrum Analyzer . . . . . 396-399  
 Spectrum Analyzer Preselector . . . . . 399  
 Spectrum Generator . . . . . 352, 369  
 Spectrum Scanner . . . . . 553  
 SPST Microwave Switch . . . . . 166  
 Square Wave Generators  
   Instruments . . . . . 311-318  
   Technical Information . . . . . 303, 304, 310  
 Stand, Sweep Drive . . . . . 390  
 Stand, Waveguide . . . . . 279  
 Standard Source . . . . . 174-177  
 Standards  
   Inductance . . . . . 253  
   Q . . . . . 253  
   Voltage . . . . . 173-177  
   Technical Information . . . . . 170, 171  
 Standards, Frequency, Time  
   Instruments . . . . . 534-551  
   Technical Information . . . . . 532  
 Standby Power Supplies . . . . . 537  
 Standing Wave Indicator . . . . . 257, 258  
 Step Recovery Diodes . . . . . 163  
 Stethoscope, Acoustic . . . . . 45  
 Storage Oscilloscope . . . . . 427  
 Strip-Chart Recorder . . . . . 111-116  
 Stripline SPST Microwave Switch . . . . . 166  
 Susceptance, Calibrated . . . . . 443  
 Sweep Delay Generators, Oscilloscope . . . . . 433, 439, 451  
 Sweep Drive . . . . . 390  
 Sweep Oscillator . . . . . 307-309, 362, 367  
 Sweep Function Generator . . . . . 307-309  
 Swept-Frequency Measurements  
   Instruments . . . . . 361-367, 441  
   Technical Information . . . . . 359, 360  
 SWR Meters  
   Instruments . . . . . 257-259  
   Technical Information . . . . . 255, 256  
 Synchronizers, Oscillator . . . . . 345  
 Synchronizer, Signal Generator . . . . . 338, 339  
 Synthesizers, Frequency  
   Instruments . . . . . 544-551  
   Technical Information . . . . . 543  
 Systems, Data Acquisition . . . . . 80-87  
 Tachometer  
   Generator . . . . . 529  
   Indicator . . . . . 529  
   Pickup, Optical . . . . . 529  
 Tape Recorder, Magnetic . . . . . 146-160  
 Telemetry Signal Generator . . . . . 354  
 Telephone Accessories . . . . . 46, 301  
 Telephone Test Equipment, Technical . . . . . 286, 287  
 Telephone Test Oscillator . . . . . 292  
 Telephone Test Set . . . . . 288, 289, 290, 291  
 Telephone Voltmeter . . . . . 290, 291  
 Temperature Monitor . . . . . 49, 51, 75  
 Temperature Probe . . . . . 75, 560  
 Terminations  
   Coaxial . . . . . 278  
   Synthesizer . . . . . 548  
   Waveguide . . . . . 278, 279  
 Test Leads . . . . . 209, 462  
 Test Oscillators . . . . . 324, 328 329  
 Test Oscillators, Audio and Ultrasonic . . . . . 305  
 Test Sets  
   ATC Transponder . . . . . 356, 357  
   Communications Systems . . . . . 280-301, 351  
   DME/ATC . . . . . 356, 357  
   Frequency Response . . . . . 179  
   ILS Receiver . . . . . 358  
   Transmission Line . . . . . 280-301  
   VOR Receiver . . . . . 358  
   X-Band . . . . . 351  
 Testmobile, Oscilloscope . . . . . 459  
 Thermal Converters . . . . . 179  
 Thermistor Mounts . . . . . 378, 379, 381  
 Thermistor Mount Calibrator . . . . . 380  
 Thermistor Temperature Probes, Medical . . . . . 57  
 Thermodilution Instrument . . . . . 75  
 Thermometer, Quartz . . . . . 560, 561  
 Time Base Plug-ins, Oscilloscope . . . . . 432, 433, 438, 439, 451, 457  
 Time Domain Reflectometer . . . . . 442  
 Time Interval Measurement . . . . . 98, 505, 518, 523, 527  
 Time Measuring Instrumentation . . . . . 534-542  
 Time Measuring Instrumentation, Technical Information . . . . . 532  
 Time Scale Translator . . . . . 540  
 Time Standards . . . . . 536, 542  
 Time Standards, Technical Information . . . . . 532  
 Timer . . . . . 98, 505, 518, 527, 554  
 Trace Recorder, Oscilloscope . . . . . 452  
 Transducers . . . . . 60, 61, 144, 145  
 Transfer Oscillator . . . . . 510-512  
 Transfer Standard . . . . . 173  
 Transformer Line Matching . . . . . 330

# FUNCTIONAL INDEX



Transistor Test Jig .....	251	Differential .....	212-215
Translator, Frequency/Time Scale .....	540	Digital .....	219-233, 306
Transmission Line Test Set .....	288-292	Integrating .....	225-227
Triangle Generators .....	306-309	RF, VHF .....	196-199, 240, 241
Trigger Countdown .....	440	Sampling .....	198, 199
Tuners, Coaxial .....	277	Technical Information .....	181-185, 210, 211, 216-218
Tuners, Waveguide .....	277	Vector .....	240, 241
Ultra Low Frequency Oscillator .....	305	VOR Receiver Test Set .....	358
Ultrasonic Medical Instrument .....	72, 73	Wall Mounts, Patient Monitors .....	57
Ultrasonic Translator Detectors .....	280-285, 563-567	Warranty .....	4
Universal Probe Carriage .....	260, 261	Wave Analyzers	
Univertter .....	355	Instruments .....	294, 295, 390, 391
Untuned Probes .....	260, 261	Technical Information .....	387-389
Up-Converter, Spectrum Analyzer .....	396	Waveguide	
Vacuum Tube Voltmeter .....	194	Adapters .....	279
Vapor Pressure Osmometer .....	34	Adjustable Shorts .....	278
Variable Attenuators .....	330, 372-374	Attenuators .....	374
Variable Persistence Oscilloscope .....	427	Broadband Probes .....	260, 261
VCG System .....	70, 71	Clamps .....	279
Vector Impedance Meter .....	242	Detector Mounts .....	260, 261
Vector Voltmeter .....	240, 241	Detectors .....	273
Vectorcardiograph System .....	70, 71	Directional Couplers .....	276
VHF Oscillator .....	340	Flexible .....	269, 270
Video Amplifier Plug-in .....	505, 523	Frequency Meters .....	530
Video Amplifiers .....	411, 412	Loads, Moving .....	278
Video Test Oscilloscopes .....	297-299	Low-Pass Filters .....	272
Viewing Hood, Oscilloscope .....	462	Noise Sources .....	385
Viscometer, Auto .....	38, 39	Phase Shifter .....	277
Viso-Cardiette Electrocardiograph .....	46, 47	Probe Carriages .....	260, 261
Viso-Scope .....	54, 55	Shorting Switch .....	279
VITS Testing .....	296	Stands .....	279
VLF Comparator .....	540	Terminations .....	278, 279
VLF Receiver .....	540	Thermistor Mounts .....	378, 379, 381
Voice Channel, Tape Recorders .....	157	Tuners .....	277
Voltage, Frequency Converters .....	235	Wavemeter .....	356, 357
Voltmeter Accessories .....	207, 208	Well Detector .....	556
Voltmeter Calibration System .....	179	Well Detector Shield .....	558
Voltmeter Calibrator .....	179	Wide Range Oscillator .....	322, 328
Voltmeters		WVVB Receiver .....	540
AC .....	188-201	X-Band Instrumentation .....	269, 502, 510, 511, 513
Automatic .....	203, 219-223	X-Y Recorders	
Battery Operated .....	195, 202	Instruments .....	100-108
DC .....	186, 187, 219-233	Technical Information .....	99



## MODEL NUMBER INDEX

GT Series Dimensional Gaging Transducers . . . . .	144, 145	140A Plug-in Oscilloscope . . . . .	426
LVDT Differential Transformer Transducers . . . . .	144, 145	141A Plug-in Oscilloscope . . . . .	427
FTA 1 Series Microforce Transducers . . . . .	60, 61, 144, 145	0151/0152/0153/0154 Step Recovery Diodes . . . . .	163
2D-2 Series X-Y Recorders . . . . .	108	155A Programmable Oscilloscope . . . . .	444
2D-2A Series X-Y Recorders . . . . .	108	175A 50 MHz Oscilloscope . . . . .	448
2D-3 Series X-Y Recorders . . . . .	108	0180/0181/0182/0183 Step Recovery Diode . . . . .	163
H01-2D-3 X-Y Recorders . . . . .	108	180A/AR Oscilloscope . . . . .	454
2FA Series X-Y Recorders . . . . .	105	185 Carbon-Hydrogen-Nitrogen Analyzer . . . . .	32
G-2 Null Detector . . . . .	119	190A Q Meter . . . . .	254
F3B Line Follower . . . . .	119	191A TV Waveform Oscilloscope . . . . .	297
TCS-3 Total Collection System . . . . .	40, 41	192A TV Waveform Oscilloscope . . . . .	298
3-7 LYsyn Series Linear Velocity Transducers . . . . .	61, 144, 145	193A TV Waveform Oscilloscope . . . . .	299
S1-4 Solid Sample Injector . . . . .	40, 41	196A/B Oscilloscope Cameras . . . . .	462
7DCDT Linear Displacement Transducers . . . . .	61, 144, 145	197A Oscilloscope Cameras . . . . .	71, 73, 460
10 Metabolism Tester . . . . .	45	200AB Audio Oscillator . . . . .	322, 323
APT 10 Series Applanation Transducers . . . . .	60, 61	200CD Wide-Range Oscillator . . . . .	322, 323
GV 10-11 Gas Sampling Valves . . . . .	40, 41	H20-200CD Low Distortion Wide-Range Oscillator . . . . .	322, 323
TPS 10 Power Supplies . . . . .	144	200SR Oscillator . . . . .	322, 323
24 DCDT Linear Displacement Transducers . . . . .	144, 145	201C Audio Oscillator . . . . .	322, 323
37P Series Temperature Probes . . . . .	57	202A Low Frequency Function Generator . . . . .	306
40D Keyboard . . . . .	119	202C Low Frequency Oscillator . . . . .	323
50B Automatic Attenuator . . . . .	40, 41	202H FM-AM Signal Generator . . . . .	353
53 Battery Converter . . . . .	130	202J Telemetry Signal Generator . . . . .	354
55 EEG/ECG Preamplifier . . . . .	51	203A Variable-Phase Function Generator . . . . .	305
60 Backflush Valve . . . . .	40, 41	204B Portable Oscillator . . . . .	324
74R Hemo-Diluter . . . . .	45	205AG, 206A Audio Signal Generators . . . . .	327
74W Hemo-Diluter . . . . .	45	207H Univerter . . . . .	355
75, 75X Blood Cell Counter . . . . .	45	208A Test Oscillator . . . . .	324
80 Pyrolyzer . . . . .	40, 41	211A Signal Generator . . . . .	358
100E Quartz Oscillator . . . . .	538	211A Square Wave Generator . . . . .	311
101A 1 MHz Oscillator . . . . .	538	211B Square Wave Generator . . . . .	311
106A/B Quartz Oscillators . . . . .	538	213B Pulse Generator . . . . .	312
107AR/BR Quartz Oscillators . . . . .	538	214A Pulse Generator . . . . .	316
0112/0113/0114 Step Recovery Diodes . . . . .	163	215A Pulse Generator . . . . .	317
112B (Delcon) Ultrasonic Translator Detector . . . . .	281	216A Pulse Generator . . . . .	318
112BRC (Delcon) Mobile Reflector . . . . .	282	218AR Digital Delay Generator . . . . .	314
112WC (Delcon) Quick Search Wand . . . . .	282	219A Dual Trigger Unit for 218AR . . . . .	314
115BR/CR Frequency Dividers and Clocks . . . . .	542	219B Dual Pulse Unit for 218AR . . . . .	314
H20-115BR/CR Frequency Dividers and Clocks . . . . .	542	219C Digital Pulse Duration Unit for 218AR . . . . .	314
116 (Delcon) Ultrasonic Translator Detector . . . . .	281	220 Temperature Controller . . . . .	40, 41
117A VLF Comparator . . . . .	540	222A Pulse Generator . . . . .	315
K10-117A Time Scale Translator . . . . .	540	230A Signal Generator Power Amplifier . . . . .	413
118 (Delcon) Ultrasonic Translator Detector . . . . .	566	232A Glide Slope Signal Generator . . . . .	358
120B 450 kHz Oscilloscope . . . . .	420	236A Telephone Test Oscillator . . . . .	292
H40/H41-120B Monitor Scopes . . . . .	56	240 Temperature Programmer . . . . .	40, 41
122A/AR Dual-Trace 200 kHz Oscilloscope . . . . .	421	0240/0241/0242/0243 Step Recovery Diodes . . . . .	163
130 Cardiac Output Computer . . . . .	75	241A Pushbutton Oscillator . . . . .	326
130C 200- $\mu$ V/cm Oscilloscope . . . . .	422	250A RX Meter . . . . .	251
0132/0133/0134 Step Recovery Diodes . . . . .	163	0251/0252/0253/0254 Step Recovery Diodes . . . . .	163
132A Dual Beam Oscilloscope . . . . .	424	260A Q Meter . . . . .	252
135 Series X-Y Recorders . . . . .	102	267 Series Fluid Pressure Transducers . . . . .	60
135A Series X-Y Recorders . . . . .	102	268 Series Fluid Pressure Transducers . . . . .	60
136A Series Two-Pen X-Y Recorders . . . . .	103	270 Pressure Transducer . . . . .	61



# MODEL NUMBER INDEX



280 Acoustic Sterhoscope .....	45	416B Ratio Meter .....	259
281A/B Waveguide-to-Coaxial Adapters .....	279	419A DC Null Meter/Ammeter .....	175, 186, 187
292A/B Microwave Adapters .....	279	420A/B Crystal Detectors, Coaxial .....	273
297A Sweep Drive .....	390	422A Crystal Detector, Waveguide .....	273
299 Portable Thermal Writing Recorder .....	128	423A Crystal Detector, Coaxial .....	273
0300 Step Recovery Diode .....	163	424A Crystal Detector, Waveguide .....	273
301 Portable Thermal Writing Recorder .....	128, 130	425A DC Microvolt-Ammeter .....	205
301B Vapor Pressure Osmometer .....	34, 35	427A Voltmeter-Multi-Function, Battery Operated .....	202
301C Auxiliary Sample Chamber for Vapor Pressure Osmometer .....	40	428B Clip-on DC Milliammeter .....	206
302A Wave Analyzer .....	390	430C Microwave Meter .....	381
310A Wave Analyzer .....	391	431C Power Meter .....	378
311A Transducer Amplifier .....	391	434A Calorimetric Power Meter .....	383
312A Wave Analyzer .....	294	440A Detector Mount .....	260, 261
H01-312A Wave Analyzer .....	294	422B Detector Probe .....	260, 261
313A Tracking Oscillator .....	294	444A Untuned Probe .....	260, 261
320 Portable Thermal Writing Recorder .....	129, 130	446B Broadband Detector Probe .....	260, 261
321 Portable Thermal Writing Recorder .....	129, 130	447B Untuned Probe .....	260, 261
322, 322A Portable Thermal Writing Recorder .....	129, 130	448A Slotted Line Sweep Adapter .....	260, 261
331A-334A Distortion Analyzers .....	392, 393	450A Stabilized Amplifier .....	408
H05-332A/334A FCC Approved Distortion Analyzers .....	293	456A AC Current Probe .....	207
340B Noise Figure Meter .....	384	457A AC-DC Converter .....	234
342A Noise Figure Meter .....	384	460AR/BR Fast Pulse Amplifiers .....	410
343A Noise Source .....	385	461A General Purpose Amplifier .....	411
345B Noise Source .....	385	462A Fast Pulse Amplifier .....	411
347A Noise Source .....	385	463A General Purpose, Precision Amplifier .....	412
349A Noise Source .....	385	465A General Purpose Amplifier .....	409
350C/D 500/600Ω Attenuators .....	330	466A General Purpose Amplifier .....	408
350 Series Preamplifiers .....	62, 63	467A Power and Voltage Amplifier .....	409
350-1500 W/350-15 Thermal Dilution System .....	75	476A Bolometer Mount, Coaxial .....	258
353A Patch Panel .....	288-289	477B Thermistor Mount, Coaxial .....	381
H02-353A Telephone Patch Panel .....	289	478A Thermistor Mount, Coaxial .....	378
H03-353A Telephone Patch Panel .....	289	485B Detector Mounts, Waveguide .....	258
354A Attenuator, Step, Coaxial .....	373	486A Thermistor Mounts, Waveguide .....	378
355C/D Attenuators, Step, Coaxial .....	372	487B Thermistor Mounts, Waveguide .....	381
362A Low-Pass Filter .....	272	489A-495A Microwave Amplifiers .....	414
373 Pulse Wave Adapter .....	47	500B/C Frequency Meters .....	529
375A Variable Attenuator, Waveguide .....	374	500X/J Viso-Cardiette Electrocardiograph .....	46
382A/B/C Variable Attenuators, Precision, Waveguide .....	374	500-601 Weather Cover .....	47
393A Variable Attenuator, Coaxial .....	372	500-1100 Mobile Cabinet .....	47
394A Variable Attenuator, Coaxial .....	372	500-1200 Mobile Table .....	47
400D/H/L Vacuum Tube Voltmeters .....	194	501 Standard Membrane Osmometer .....	36, 37
400E/EL High Accuracy AC Voltmeters .....	188, 189	502 High Temperature Membrane Osmometer .....	36, 37
400F/FL Fast Response AC Voltmeters .....	190, 191	503 Low Temperature Membrane Osmometer .....	36, 37
400GL High Accuracy DB Voltmeter .....	192, 193	506A Optical Tachometer .....	529
402 High Efficiency Gas Chromatograph .....	22, 23	508A/B/C/D Tachometer Generators .....	529
403A/B AC Portable Voltmeters .....	195	520A Power Supply .....	485
410B/C Multi-Function Voltmeters .....	200, 201	521A/C/D/E/G Electronic Counter .....	526
411A RF Millivoltmeter .....	197	522B Electronic Counter .....	524
412A DC Voltmeter-Ohmmeter-Ammeter .....	204	523C/D Electronic Counter .....	525
413A DC Null Voltmeter .....	187	524C/D Electronic Counter .....	522
414A DC/OHMS Autovoltmeter .....	203	525A/B/C Plug-ins for 524C/D .....	523
415B Standing Wave Indicator .....	258	526A/B/C/D Plug-ins for 524C/D .....	523
415E SWR Meter .....	257	532A/B Frequency Meters, Waveguide .....	530



## MODEL NUMBER INDEX

536A Frequency Meter, Coaxial .....	530	786/7D, 788/9C Directional Detectors, Coaxial .....	274, 275
537A Frequency Meter, Coaxial .....	530	796/7D Directional Coupler, Coaxial .....	274, 275
540B Transfer Oscillator .....	511	798C Directional Coupler, Coaxial .....	274, 275
560A Digital Recorder .....	97	801C Power Supply .....	491
561B Digital Recorder .....	97	805C Slotted Line .....	260
562A Digital Recorder .....	96	809C Probe Carriage .....	260
563 Rapid Developer .....	66, 67	810B Slotted Line, Waveguide .....	260
565A Digital Recorder .....	97	814B Carriage, Probe .....	260
569B Viso-Scope .....	64, 65, 67	815B Slotted Section, Waveguide .....	260
570A/571B Digital Clock .....	98	816A Slotted Section, Coaxial .....	260
580A/581A Digital-to-Analog Converter .....	98	851B Spectrum Analyzer .....	396
585DT-595DT Linearsyn Transducers .....	144, 145	E01-851B Spectrum Analyzer .....	399
606A/606B HF Signal Generator .....	334	860-4300 Narrow-Band Differential DC Amplifier .....	406
608C-608F VHF Signal Generator .....	336	870A Slide-Screw Tuner, Waveguide .....	277
612A UHF Signal Generator .....	341	872A Coaxial Slide-Screw Tuner .....	277
614A UHF Signal Generator .....	344	874A/B Calibrated Susceptance Standard .....	443
616B UHF Signal Generator .....	344	885A Waveguide Phase Shifter .....	277
618C SHF Signal Generator .....	346	890A MVR Power Supply .....	484
620B SHF Signal Generator .....	346	895A MVR Power Supply .....	484
623B/624C RF Test Set .....	351	907A Sliding Load, Coaxial .....	278
626A/628A SHF Signal Generator .....	348	908A Low-Reflection Termination, Coaxial .....	278
651B Test Oscillator .....	328	909A Low-Reflection Termination, Coaxial .....	278
651-32 Master Two-Step .....	47	910A/B Terminations, Coaxial .....	278
652A Test Oscillator .....	329	X913A High-Power Termination, Waveguide .....	279
658-2000 Galvanometer Driver Amplifier .....	143	914A/B Moving Loads, Waveguide .....	278
658-2900 Low-Gain Amplifier .....	143	920A/B Adjustable Shorts, Waveguide .....	278
658-3400 Medium-Gain Amplifier .....	143	X923A Moving Short, Waveguide .....	278
680 Strip Chart Recorder .....	111	X930A Shorting Switch, Waveguide .....	279
700 Series Gas Chromatographs and Accessories .....	24, 25, 26	P932A Harmonic Mixer, Waveguide .....	265
711A DC Power Supply .....	491	934A Harmonic Mixer, Coaxial .....	511
712B Power Supply .....	491	938A Frequency Doubler Set .....	350
715A, 716B Klystron Power Supplies .....	492	940A Frequency Doubler Set .....	350
721A Power Supply .....	473	958-1500 High-Gain DC Preamplifier .....	142
724BR Standby Power Supply .....	537	958-2900 Medium-Low-Gain DC Preamplifier .....	142
725AR Power Supply .....	537	958-3400 Medium-Gain DC Preamplifier .....	142
735A DC Transfer Standard .....	173	958-3600 Low-Gain DC Preamplifier .....	142
738BR Voltmeter Calibrator .....	179	1001/2/3/4/6 High Conductance Diodes .....	165
E02-738BR Voltmeter Calibration System .....	179	1051A Combining Case .....	568, 569
740B DC Standard/DC Differential Voltmeter .....	174, 175, 212	1052A Combining Case .....	568, 569
741B AC-DC Differential Voltmeter/DC Standard .....	176, 177, 213	1102B Accessory Kit .....	440
752 Series Directional Couplers, Waveguide .....	276	1103A Trigger Countdown .....	440
760-3 Cardiometer Plug-in .....	63	1104A/1106A Trigger Countdown .....	440
760-52 Rotary Platform .....	54	1105A/1106A 20 psec Pulse Generator .....	312
760-53 Calibrated Temperature Bridge .....	60, 61	1110A/1111A AC Current Probe/Amplifier .....	453
760 Series Preamplifiers .....	62, 63	1116A-1118A Testmobiles .....	459
769A Viso-Scope .....	54	K41-1118A Testmobile for Medical Scopes .....	56
774-6D-778D Dual Directional Couplers, Coaxial .....	274	1119A Testmobile .....	459
775 Prep. Gas Chromatograph .....	27, 28	1280 Series Pressure Transducers .....	61
776 Prep. Gas Chromatograph .....	29, 30	1281 Series Pressure Transducers .....	144
780B Viso Monitor .....	50	1400A Differential Amplifier for 140A/141A .....	430
780 Series Patient Monitoring and Resuscitation Instruments .....	48-57	1401A Dual-Trace Amplifier for 140A/141A .....	429
X781A Directional Detector, Coaxial Input, Waveguide .....		1402A Dual-Trace Amplifier for 140A/141A .....	429
Output .....	274, 275	1403A Guarded Differential Amplifier for 140A/141A .....	430

# MODEL NUMBER INDEX



1405A Dual-Trace Amplifier for 140A/141A .....	429	2545 Tape Punch Coupler .....	83
1406A High Sensitivity Amplifier for 140A/141A .....	431	2546B Magnetic Tape Coupler .....	83
1407A High Sensitivity Amplifier for 140A/141A .....	431	2550 Hot Carrier Microwave Diode .....	164
1410A Sampling Vertical Amplifier for 140A/141A .....	436	2560A System Programmer .....	82
1411A Sampling Vertical Amplifier for 140A/141A .....	434	2565 Hot Carrier Microwave Diode .....	164
1415A Time Domain Reflectometer for 140A/141A .....	442	2590B Transfer Oscillator .....	510
1416A Swept Frequency Indicator for 140A/141A .....	441	2602/2603 Hot Carrier Microwave Diodes .....	164
1420A Time Base for 140A/141A .....	432	2650A/2654A Microwave Synchronizers .....	345
1421A Time Base/Delay Generator for 140A/141A .....	433	2701A/2702A X-Y Translator .....	94
1422A/1423A Time Base for 140A/141A .....	432	2734B Tape Editor .....	94
1424A Sampling Time Base for 140A/141A .....	438	2800 Series Quartz Thermometer .....	560, 561
1425A Sampling Time Base and Generator for 140A/141A .....	439	2900 Hot Carrier Commercial Diode .....	164
1430A/31A/32A Sampling Heads for 1411A .....	435	2900B Input Scanner .....	80
1550A Oscilloscope Programmer .....	447	2901A Input Scanner .....	80
1506A Heart Sound Amplifier .....	74	2902A/B Slave Scanner .....	80
1507A Vector Programmer .....	70, 71	2911A/B Crossbar Scanner .....	82
1520A Vector System for VCG .....	70, 71	2911C Scanner Programmer .....	82
1750B Dual-Trace Amplifier for 175A .....	449	2918A Thermometer Scanner .....	560
1752A High-Gain Amp. for 175A .....	449	2911C Scanner Programmer .....	82
1754A Four-Channel Amp. for 175A .....	450	2918A Thermometer Scanner .....	560
1755A Dual-Trace Amp. for 175A .....	450	3001/3002 PIN Diodes .....	165
1780A Auxiliary Plug-in for 175A .....	451	3101/3002 PIN Diodes .....	165
1781B Sweep Delay Generator for 175A .....	451	3200B VHF Oscillator .....	340
1782A Display Scanner for 175A .....	452	3201/3202 PIN Diodes .....	165
1784A Strip Chart Recorder Plug-in for 175A .....	452	3211A Sweep Oscillator .....	361
1801A Amplifier Plug-in for 180A .....	458	3212A/3217A RF Plug-ins for 3211A .....	361
1820A Time Base for 180A .....	457	3221A Marker Plug-in for 3211A .....	361
1821A Time Base and Delay Generator for 180A .....	457	3300A Function Generator .....	307
2010 Series Data Acquisition System .....	84	3301A Auxiliary Plug-in for 3300A .....	307
2013 Series Data Acquisition System .....	86	3302A Trigger Phase Lock Plug-in for 3300A .....	308
2015 Series Data Acquisition System .....	87	3304A Sweep/Offset Plug-in for 3300A .....	308
2017 Linearizing System .....	92	3400A True RMS Voltmeter .....	196, 234
2031 Digital Plotting System .....	94	3406A RF Sampling Voltmeter .....	198, 199
2116A Computer, Instrumentation .....	83, 88, 91	3420A/B DC Differential Voltmeter/Ratiometer .....	214, 215
2212A Voltage-Frequency Converter .....	235	3430A 4 Digit Digital Voltmeter .....	219
2301/2302/2303 Hot Carrier Switching Diodes .....	164	3439A Plug-in Digital Voltmeter .....	220
2350 Hot Carrier Microwave Diode .....	164	3440A Plug-in Digital Voltmeter .....	86, 221
2365 Hot Carrier Microwave Diode .....	164	3441A Range Selector for 3439A/3440A .....	222
2401C Integrating Digital Voltmeter .....	225-227	3442A Automatic Range Selector for 3439A/3440A .....	222
2410B AC/Ohms Converter .....	80, 227	3443A High-Gain/Auto Range Unit for 3439A/3440A .....	222
2411A Guarded Data Amplifier .....	81, 227	3444A DC Multi-Function Unit for 3439A/3440A .....	223
2417A Data Linearizer .....	81	3445A AC/DC Range Unit for 3439A/3440A .....	224
2460A Operational Amplifier .....	407	3446A AC/DC Remote Unit for 3439A/3440A .....	224
2461A Amplifier Plug-in .....	407	3459A Digital Voltmeter .....	229
2470A Data Amplifier .....	403	3460B Digital Voltmeter .....	87, 228, 229
2480 Series Signal Conditioners .....	80, 562	H04-3460A Digital Voltmeter .....	232, 233
2481A Signal Conditioner .....	80, 562	3461A AC-Ohms/DC Converter/Preamplifier .....	230, 231
2482N Signal Conditioner .....	80, 562	3501 SPST Microwave Switch .....	166
2509A Digital Clock .....	82	3503 SPST Microwave Switch .....	166
2515A Digital Scanner .....	81	3504 SPST Microwave Switch .....	166
2520 Hot Carrier Microwave Diode .....	164	3505 SPST Microwave Switch .....	166
2526 Card Punch Coupler .....	83	3528A Wide Aperture Probe for 428B .....	206
2539A Digital Comparator .....	82	3529A Magnetometer Probe for 428B .....	206



## MODEL NUMBER INDEX

3530 SPST Microwave Switch	166	4800A, 4801A Vector Impedance Meter	242
3540 SPST Microwave Switch	166	4815A RF Vector Impedance Meter	243
3550 SPST Microwave Switch	166	4900A (Delcon) Cable Fault Locator	284
3550A Portable Test Set	288, 289	4901A (Delcon) Cable Fault Locator	284
3551 SPST Microwave Switch	166	4905A (Delcon) Ultrasonic Translator Detector	281, 565
3555A Telephone Voltmeter	290, 291	4910B/C (Delcon) Open Pair Locator	285
3570 SPST Microwave Switch	166	4917A (Delcon) Ultrasonic Translator Detector	565
3571 SPST Microwave Switch	166	4918A (Delcon) Ultrasonic Translator Detector	566
3580 SPDT Microwave Switch	166	4950A (Delcon) Ultrasonic Translator Detector	567
3604A Voice Channel for Tape Recorders	157	5050A Digital Printer	95
3680A AC Power Supply	157	5060A Cesium Beam Frequency Standard	534
3734A Frequency Counter	513	E20-5060A Cesium Beam Frequency Standard	536
3735A Frequency Counter	513	K02-5060A Power Supply	536
3900 Series Tape Recorders	146-160	5085A Standby Power Supply	537
3907B Magnetic Tape Recorder	150	5100A Frequency Synthesizer	546
3907-04A Tape Loop Adapter	151	5102A Frequency Synthesizer	519
3907-06A Voice Channel Amplifier	151	5103A Frequency Synthesizer	549
3907-07A Input Signal Coupler	151	5105A Frequency Synthesizer	544
3907-11A Remote Control Module	151	5110A/B Frequency Synthesizer Driver	548
3914B Magnetic Tape Recorder	150	5201L Scaler-Timer	554
3914-04A Tape Loop Adapter	151	5202L Scaler-Timer	554
3917A Magnetic Tape Recorder	150	5203L Scaler-Timer	554
3924A Magnetic Tape Recorder	150	5210A/B Frequency Meter/FM Discriminator	528
3950 Magnetic Tape Recorders	155-160	5211A/B Electronic Counters	514
3955A/B/C/D Magnetic Tape Recorders	155-160	H22-5211B Electronic Counter	514
4104 Gallium Arsenide Infrared Source	168	5212A Electronic Counter	515
4106 Gallium Arsenide Infrared Source	168	5214L Preset Counter	518
4107 Gallium Arsenide Infrared Source	168	5223L Electronic Counter	516
4201 PIN Photodiode	168	5232A Electronic Counter	515
4203 PIN Photodiode	168	5233L Electronic Counter	516
4204 PIN Photodiode	168	5244L Electronic Counter	507
4204A Digital Oscillator	325	5245L Electronic Counter	500
4205 PIN Photodiode	168	5246L Electronic Counter	499
4260A Universal Bridge	250	5251A Frequency Converter Plug-in	502
4301 Photon Coupled Isolator	168	5252A Prescaler Plug-in	506
4303 Photon Coupled Isolator	168	5253B Frequency Converter Plug-in	502
4310 Photon Coupled Isolator	168	5254B Frequency Converter Plug-in	502
IN4456/IN4457 High Conductance Diodes	165	5255A Frequency Converter Plug-in	502
4500 Multi-Channel Recording System	134, 135	5258A Prescaler Plug-in	506
4501 Photochopper	167	5260A Automatic Frequency Divider	512
4502 Photochopper	167	5261A Video Amplifier Plug-in	505
4503 Photochopper	167	5262A Time Interval Plug-in	505
4504 Photochopper	167	5264A Preset Unit Plug-in	504
4505 Photomodulator	167	5265A Digital Voltmeter Plug-in	506
4506 Photomodulator	167	5275A Time Interval Counter	527
4507 Photo Controlled Resistor	167	5280A Reversible Counter	520
4508 Photo Controlled Resistor	167	5285A Reversible Counter Plug-in	520
4508B/BT Oscillograph	67	5512A Electronic Counter	515
4524B Eight-Channel Recording Subsystem	134	5532A Electronic Counter	515
4561B Oscillograph	66	5551A Power Supply	558
4564B Oscillograph	67	5552A Spectrum Scanner	553
4564-01A Optical Recorder	135	5601A Numerical Readout	75
4568B Oscillograph	67	5636 RF Test Set	351

# MODEL NUMBER INDEX



5700A Series Industrial Recorders	112, 113	7702A 2 Channel Oscillographic Recording System	123
5750 Series Gas Chromatographs and Accessories	18-21	7704A 4 Channel Oscillographic Recording System	124
5801A Single Channel Electrometer	18-21	7706A 6 Channel Oscillographic Recording System	125, 126
5802A Electron Capture Detector	18-21	7708A 8 Channel Oscillographic Recording System	125, 126
5803A Electron Capture Detector	22, 23	7709A 8 Channel Oscillographic Recording System	125, 126
5804A Cross-section Detector	22, 23	7712AT 2 Channel Oscillographic Recording System	64, 65
5810A Add-on Oven for Model 776	29, 30	7714A 4 Channel Oscillographic Recording System	64, 65
5901B Auto-Viscometer	38, 39	7716A-7720A 6-8 Channel Oscillographic Recording Systems	64, 65
5903A Programmer Printer	38, 39	7726A 6 Channel Oscillographic Recording System	125, 126
5910A Constant Temperature Bath	38, 39	7728A 8 Channel Oscillographic Recording System	125, 126
6101A-6116A STB Power Supplies	476, 477	7734A 4 Channel Oscillographic Recording System	66
6177A-6186A CCB Power Supplies	478, 479	7858A 8 Channel Ink Recording System	131, 132, 133
6200B-6209B LAB Power Supplies	470, 471	7858-01A 8 Channel Feedback Ink Recorder	131-133
6220B-6226B MPM Power Supplies	473	8000A Pulse Generator	313
6251A-6258A DPR Power Supplies	474, 475	8001A Pulse Generator	313
6260A-6274A LVR Power Supplies	482, 483	8400B Microwave Spectrometer	31
6281A MPB-3 Power Supply	474, 475	8402B Power Meter Calibrator	380
6282A MPB-5 Power Supply	474, 475	8403A Modulator	370
6284A MPB-3 Power Supply	474, 475	8405A Vector Voltmeter	240
6285A MPB-5 Power Supply	474, 475	8406A Frequency Comb Generator	396
6286A MPB-5 Power Supply	474, 475	8410A Network Analyzer	244-247
6289A MPB-3 Power Supply	474, 475	8411A Harmonic Frequency Converter	244-247
6290A MPB-5 Power Supply	474, 475	8413A Phase-Gain Indicator	244-247
6291A MPB-5 Power Supply	474, 475	8414A Polar Display	244-247
6294A MPB-3 Power Supply	474, 475	8430-6A Bandpass Filters, Coaxial	272
6296A MPB-5 Power Supply	474, 475	8439A 2 GHz Notch Filter, Coaxial	396-398
6299A MPB-3 Power Supply	474, 475	8441A Preselector, Voltage Tunable	399
6343A-6357A MOD Power Supplies	488, 489	8442A 20 MHz Crystal Filter	396-398
6384A-6388A ICS Power Supplies	480, 481	8470A Crystal Detector	273
6427B-6448B SCR-1P Power Supplies	485	8491A/B Attenuator, Fixed, Coaxial, Pad	373
6450A-6459A SCR-3 Power Supplies	486	8492A Attenuator, Fixed, Coaxial, Pad	373
6463A-6483B SCR-10 Power Supplies	487	8551B/851B Spectrum Analyzer	396-398
6515A-6516A HVB Power Supplies	472	K15-8551B Spectrum Analyzer Up-Converter	396
6521A-6525A HVR Power Supplies	484	8614A/8616A Signal Generator	342, 343
6823A/6824A PS/A Power Supplies	493	8614B/8616B Signal Source	342, 343
6920B AC/DC Meter Calibrator	168	K01-8690A Calibrator	365
7000A/7001A X-Y Recorder	106	8690A Sweep Oscillator, Signal Source	362
7005A X-Y Recorder	104	E31-8690 Power Calibration System	380
7030A X-Y Recorder	101	8691A/B-8698A RF Units for 8690A	362-365
7035A X-Y Recorder	100	8706A Control Unit	362-365
7100-0466 Carrying Case for 500 Viso-Cardiette	47	8707A RF Unit Holder	362-365
7100B Strip Chart Recorder	114	8708A Synchronizer	335-339
7101B Strip Chart Recorder	114	8730 Series PIN Modulators	370, 371
7127A Strip Chart Recorder	116	8740A Transmission Test Unit	246
7128A Strip Chart Recorder	116	8742A/8741A Reflection Test Unit	246
7214A Ultrasonic Diagnostic System	72, 73	8800 Series Preamplifiers	137-141
7500A Line Follower System	119	8875A Differential Amplifier	404, 405
7501A Line Follower System	119	8900B Peak Power Calibrator	382
7502A Line Follower System	119	8905A Wavemeter	356, 357
7560A Log Converter	117	8925A DME/ATC Test Set	356, 357
7561A Log Converter	117	00103A Inductor for 260A	253
7590C Automatic Data Plotting System	107	00127A Set of Sixteen 00103A	253
7701A 1 Channel Recording System	122	00128A Set of Seventeen 00103A	253



## MODEL NUMBER INDEX

00513A Q Standard for 260A .....	253	10457A-10458A 75 Ohm Adapters .....	443
00515A Coaxial Adapter Kit for 250A .....	251	10475A/76A Drawers for 1117B .....	459
00518A Q Standard for 260A .....	253	10477A/78A Blank Plug-ins for 140A/141A .....	426
00538A Set of five 00518A and one 00513A .....	253	10479A Tilt Tray for 1119A .....	459
00564A Coupling Unit for 260A .....	253	10480A Storage Cabinet for 1119A .....	459
00590A Inductor for 190A .....	254	10501A Cable Assembly .....	209
00591A Set of six 00590A .....	254	10502A Cable Assembly .....	209
10001A/B/C/D Voltage Divider Probes .....	453	10503A Cable Assembly .....	209
10002A/B/C/D Voltage Divider Probes .....	453	10509A Loop Antenna .....	540
10003A/B Voltage Divider Probes .....	453	10510A 50 Ohm Synthesizer Driver Termination .....	548
10009A 10:1 Divider, WECO Connector Tip .....	298	10511A Spectrum Generator .....	352
10010C BNC Probe Tip .....	453	10514A Double Balanced Mixer .....	369
10025A Voltage Probe .....	453	10515A Frequency Doubler .....	352
10035A Probe Tip Kit .....	453	10520A Time Scale Crystal Kit .....	535
10100A/B 50-Ohm Terminations .....	462	10531A Filter Kit for 5210A/B .....	528
10110A/10111A BNC-to-Binding Post Adapters .....	462	10601A-10614A Scintillation Detectors .....	556
10120A-28A Cables .....	462	10615A Scintillation Preamplifier .....	556
10129A/10130A Interconnecting Cables for 155A/1550A .....	447	10650A Lead Shield .....	558
10166A Panel Cover for 180A .....	458	11000A Cable Assembly .....	209
10167A Carrying Cover for 180A .....	458	11001A Cable Assembly .....	209
10175A/B Viewing Hood .....	462	11002A Test Lead .....	209
10176A Viewing Hood .....	462	11003A Test Lead .....	209
10179A External Graticule Kit .....	298	11004A, 11005A Line Matching Transformers .....	301, 330
10200B Sync Probe .....	440	11018A Adapter (11039A to 410B) .....	208
10201A/B/C/D Resistive Divider Probes .....	440	11021A Probe for 425A .....	205
10203A 100:1 Divider Probe Tip .....	437	11027A Probe Kit for 411A .....	197
10204A Blocking Capacitor .....	318	11033A Shunt Resistor .....	208
10208A Blocking Capacitor Probe Tip .....	440	11035A Cable Assembly .....	330
10209A Blocking Capacitor Probe Tip .....	440	11036A AC Probe for 410C .....	208
10214A 10:1 Divider for Scale Tip .....	437	11039A-11041A Capacitive Voltage Divider for 400 Series Voltmeters .....	207
10216A Isolator for Scale Tip .....	437	11042A, 11043A Probe Coaxial T Connector .....	208
10217A Blocking Capacitor for Probe Tip .....	437	11044A DC Voltage Divider for 410B .....	207
10218A BNC Adapter for Probe Tip .....	437	11045A DC Voltage Divider for 410C .....	207
10219A GR Adapter for Probe Tip .....	437	11046A Combining Case .....	568
10220A Microdot Adapter for Probe Tip .....	437	11048B 50 Ohm Feed-Thru Termination .....	330
10221A 50 Ohm Tee for Probe Tip .....	437	11049A Thermal Converter, 3 V rms .....	179
10223A Microdot Adapter for Probe Tip .....	437	11050A Thermal Converter, 1 V rms .....	179
10240A Blocking Capacitor .....	317	11051A Thermal Converter, 0.45 V rms .....	179
10351A Carrying Case for 196A/B .....	462	11064A Probe Kit for 3406A .....	199
10352A Grafak Camera Back for 197A .....	461	11066A Current Shunt, 0.01 ohm .....	208
10353A Polaroid Camera Back for 197A .....	461	11071A Accessory Kit for 3406A .....	198-199
10354A Camera Viewing Hood Replacement Plate .....	461	11074A Voltage Divider Probe for 400 Series .....	208
10355A-10357A Oscilloscope Camera Adapters .....	461	11103A-05A Standard Resistors .....	172
10358A Carrying Case for 197A .....	461	11500A Cable Assembly .....	209
10359A Camera Viewing Lens .....	461	11501A Cable Assembly .....	209
10360A/10362A Oscilloscope Camera Adapters .....	461	11503A Flexible Waveguide, P-Band .....	270
10400B Plug-in Extender Cable for 175A .....	452	11504A Flexible Waveguide, X-Band .....	269
10402A Plug-in Extender Cable for 175A .....	452	11505A Bench Stand for 297A .....	390
10403A Alignment Attenuator for 175A .....	452	11507A Output Terminal .....	335
10404A Vertical Test Adapter for 175A .....	452	11508A Output Cable .....	338
10405A Vertical Response Tester for 175A .....	452	11509A Fuse Holder .....	338
10451A Multipulser .....	317	11515A & 16A Adapters, Square-to-round Waveguide Flange .....	271
10452A-10456A Rise Time Converters .....	443		

**MODEL NUMBER INDEX**

11517A-521A Spectrum Analyzer, Waveguide Mixers, Adapters .....	396, 398	17006A-17008A Roll Chart Adapter .....	118
11527A Adapter, 8478A/B to 431A/B .....	379	17009A/B Character Printer .....	119
11528A Adapter, 478A, 486A, 8478A/B to 430C .....	379	17500A-17504A Recorder Input Modules .....	115, 116
11530A Probe for 312A .....	294, 295	18000A Underground Duct Probe .....	282
11536A 50-Ohm Tee, for 8405A .....	241	18501A-18510A Thermistor Probes .....	41
11539A Reproduce Trace Selector .....	157	18511A-18516A, 18543A Osmometer Thermostats .....	41
11540A Waveguide Stand (formerly Model 24) .....	279	18526A Variable Temperature Controller .....	41
11541A-11548A Waveguide Clamps (formerly Model 25) .....	279	19030A Backflush Valve .....	40, 41
11549A Power Splitter for 8405A .....	241	19034A Effluent Splitter .....	40, 41
11553A Pack Sensor for Tape Systems .....	157	19035A Inlet Splitter .....	40, 41
11570A Accessory Kit for 8405A .....	241	19046A Gas Purifier .....	40, 41
13505A Isolator-Monitor for 8925A .....	356, 357	19047A-19048A, 19051A Gas Sampling Valves .....	40, 41
13510A Transistor Test Jig .....	251	19055A Total Collection System .....	40, 41
13515A Frequency Doubler Probe for 3200B .....	340	60065A SLOT Power Supply .....	490
14012A Temperature Probe .....	75	60123A SLOT Power Supply .....	490
14500A Rack Mounting Assembly .....	491	60125A SLOT Power Supply .....	490
14503A, 14505A Rack Mounting Assembly .....	489	60244A SLOT Power Supply .....	490
14513A-14525A Rack Mounting Assembly .....	472	60285A SLOT Power Supply .....	490
		72007 Ultrasonic Contact Probe .....	556



# CENTRAL AND SOUTH AMERICA



## SALES & SERVICE OFFICES



### ARGENTINA

①

- ✦ Mauricio A. Suárez  
Telecomunicaciones  
Carlos Calvo 224  
Buenos Aires  
Tel: 30-6312, 34-9087  
Cable: TELEPILOT Buenos Aires
- ✦ Vigliocco & Brennan S.C.p.A.  
Corrientes 3989, 1° 1  
Buenos Aires  
Tel: 86-7763, 86-2271  
Cable: BIOTRONICA Buenos Aires
- ✦ Lutz, Ferrando y Cia. S.A.  
Florida 240 (R 5)  
Buenos Aires  
Tel: 46-7241, 46-1635  
Cable: OPTICA Buenos Aires

### BRAZIL

②

- ✦ Ciental, Importacao e Comercio Ltda.  
Rua Cleto Campelo, 44 - 5° andar  
Reolte

③

- ✦ Ciental, Importacao e Comercio Ltda.  
Avenida 13 de Maio, 13 - 22° andar  
Rio de Janeiro G.B.

- ✦ Forméd S.A.  
Av. Churchill 129  
Grupo 304 (ZC-00)  
Rio de Janeiro G.B.  
Tel: 22-6016, 52-4564  
Cable: FORMEDICO Rio de Janeiro

④

- ✦ Ciental, Importacao e Comercio Ltda.  
Rua Des. Eliseu Guilherme, 62  
Sao Paulo 8  
Tel: 70-2318  
Cable: CIENTALCO Sao Paulo

- ✦ Forméd S.A.  
Rua Coronel Oscar Porto, 1217  
Peralso  
Sao Paulo  
Tel: 70-4364

### CHILE

⑤

- ✦ Héctor Calcagni  
Casilla 13942  
Santiago  
Tel: 490.505, 393.119

- ✦ General Machinery Co., Ltda.  
Paraguay 486  
Casilla 13910  
Santiago  
Tel: 31123, 31124  
Cable: GEMCO Santiago

### COLOMBIA

⑥

- ✦ General Electric de Colombia, S.A.  
Apartado Aéreo 6799 y 3744  
Avenida de Las Americas 41-31  
Bogota  
Tel: 477-901/9  
Cable: GELCOLSA Bogota

### COSTA RICA

⑦

- ✦ Lic. Alfredo Gallagos Gurdian  
Apartado 3243  
San José  
Tel: 21-86-13  
Cable: GALGUR San José

### ECUADOR

⑧

- ✦ J. A. Vizcaino V. & Cia.  
García Moreno No. 1224  
Casilla 2925  
Quito  
Tel: 13697  
Cable: VIZCAINO Quito

### EL SALVADOR

⑨

- ✦ Electrónica  
Apartado Postal 1589  
San Salvador  
Tel: 4683

### GUATEMALA

⑩

- ✦ Olander Associates Latin America  
Apartado 1226  
7a. Calle, 0-22, Zona 1  
Guatemala City  
Tel: 22812  
Cable: OLALA Guatemala City

### HONDURAS

⑪

- ✦ Roberto L. Rodríguez  
Apartado Postal No. 4  
Tegucigalpa, D.C.  
Tel: 2-2871  
Cable: RODRIGUEZ Tegucigalpa

### MEXICO

⑫

- ✦ Hewlett-Packard Mexicana,  
S.A. de C.V.  
Eugenia 408, Dept. 1  
Mexico 12, D.F.
- ✦ Equipo para Hospitales, S.A.  
Tonala 161  
Mexico 7, D.F.  
Tel: 25-87-36, 14-82-71

### NICARAGUA

⑬

- ✦ Roberto Terán G.  
Edificio Tarán  
Apartado Postal 689  
Managua  
Tel: 3451, 3452  
Cable: ROTERAN Managua

### PANAMA

⑭

- ✦ Electrónico Balboa, S.A.  
P.O. Box 4929  
Panama City  
Tel: 3-0833  
Cable: ELECTRON Panama City

✦ Electronic instrumentation,  
pages 76-569 in this catalog

✦ Medical instrumentation,  
pages 42-75 in this catalog

✦ Chemical instrumentation,  
pages 15-41 in this catalog

### PERU

⑮

- ✦ Fernando Ezeta B.  
Av. Petit Thouars 4719  
Casilla 3061  
Lima  
Tel: 50346  
Cable: FEPERU Lima

- ✦ H. W. Kessel S.A.  
Apartado 552  
Av Corpac 312 San Isidro  
Lima  
Tel: 23900  
Cable: KESSEL Lima

### PUERTO RICO

⑯

- ✦ San Juan Electronics, Inc.  
Ponce de León No. 150, Stop 3  
Pta. de Tierra Sta.  
San Juan  
Tel: (809) 725-3342  
Cable: SATRONICS San Juan

### URUGUAY

⑰

- ✦ Pablo Ferrando  
S.A. Comercial e Industrial  
Sarandi, 675  
Casilla de Correo 370  
Montevideo  
Tel: 89631  
Cable: RADIUM Montevideo

### VENEZUELA

⑱

- ✦ Citac, C.A.  
Edif. Arisan-Of. #4  
Avda. Francisco de Miranda  
Apartado del Este 10934 Chacalto  
Caracas  
Tel: 71-88.05  
Cable: CITECAL Caracas

### FOR AREAS NOT LISTED, CONTACT:

Hewlett-Packard Inter-Americas  
1501 Page Mill Road  
Palo Alto, California 94304  
Tel: (415) 326-7000  
TWX: 910-373-1267  
Telex: 034-8461  
Cable: HEWPACK Palo Alto

# SALES & SERVICE OFFICES



# UNITED STATES AND CANADA

## ALABAMA

- ① P.O. Box 4207  
2003 Byrd Spring Road S.W.  
Muntville 35802  
Tel: (205) 881-4591  
TWX: 510-579-2204

## ARIZONA

- ② 3009 North Scottsdale Road  
Scottsdale 85251  
Tel: (602) 945-7601  
TWX: 910-950-1282

- ③ 232 South Tucson Boulevard  
Tucson 85716  
Tel: (602) 623-2564  
TWX: 910-952-1162

## CALIFORNIA

- ④ 3939 Lankershim Boulevard  
North Hollywood 91604  
Tel: (213) 877-1282  
TWX: 910-499-2170

- ⑤ 1101 Embarcadero Road  
Palo Alto 94303  
Tel: (415) 327-6500  
TWX: 910-373-1280

- ⑥ 2591 Carlsbad Avenue  
Sacramento 95821  
Tel: (916) 482-1463  
TWX: 910-367-2092

- ⑦ 1055 Shafter Street  
San Diego 92106  
Tel: (714) 223-8103  
TWX: 910-335-2000

## COLORADO

- ⑧ 7965 East Prentice  
Englewood 80110  
Tel: (303) 771-3455  
TWX: 910-935-0705

## CONNECTICUT

- ⑨ 508 Tolland Street  
East Hartford 06108  
Tel: (203) 289-9394  
TWX: 710-425-3416

- 111 East Avenue  
Norwalk 06851  
Tel: (203) 853-1251  
TWX: 710-468-3750

## DELAWARE

- ⑩ 3941 Kennett Pike  
Wilmington 19807  
Tel: (302) 655-6161  
TWX: 510-666-2214

## FLORIDA

- ⑪ Suite 106  
9999 N.E. 2nd Avenue  
Miami Shores 33138  
Tel: (305) 758-3626  
TWX: 810-848-7262

- ⑫ P.O. Box 20007  
Herndon Station 32814  
621 Commonwealth Avenue  
Orlando  
Tel: (305) 425-5541  
TWX: 810-850-0113

- ⑬ P.O. Box 8128  
Madeira Beach 33708  
410 150th Avenue  
St. Petersburg  
Tel: (813) 391-0211  
TWX: 810-863-0366

## GEORGIA

- ⑭ 2340 Interstate Parkway  
Atlanta 30327  
Tel: (404) 436-6181  
TWX: 810-751-3283

## ILLINOIS

- ⑮ 5500 Howard Street  
Skokie 60076  
Tel: (312) 677-0400  
TWX: 910-223-3613

## INDIANA

- ⑯ 4002 Meadows Drive  
Indianapolis 46205  
Tel: (317) 546-4891  
TWX: 810-341-3263

## LOUISIANA

- ⑰ P.O. Box 856  
1942 Williams Boulevard  
Kenner 70062  
Tel: (504) 721-6201  
TWX: 810-955-5524

## MARYLAND

- ⑱ 6707 Whitestone Road  
Baltimore 21207  
Tel: (301) 944-5400  
TWX: 710-862-0850

- ⑲ P.O. Box 727  
Twinbrook Station 20851  
12303 Twinbrook Parkway  
Rockville  
Tel: (301) 427-7560  
TWX: 710-828-9684

## MASSACHUSETTS

- ⑳ Middlesex Turnpike  
Burlington 01803  
Tel: (617) 272-9000  
TWX: 710-332-0382

## MICHIGAN

- ㉑ 24315 Northwestern Highway  
Southfield 48076  
Tel: (313) 353-9100  
TWX: 810-232-1532

## MINNESOTA

- ㉒ 2459 University Avenue  
St. Paul 55114  
Tel: (612) 646-7881  
TWX: 910-563-3734

## MISSOURI

- ㉓ 9208 Wyoming Place  
Kansas City 64114  
Tel: (816) 333-2445  
TWX: 910-771-2087

- ㉔ 2812 South Brentwood Boulevard  
St. Louis 63144  
Tel: (314) 644-0220  
TWX: 910-760-1670

## NEW JERSEY

- ㉕ Crystal Brook Professional Bldg.  
Route 35  
Eatontown  
Tel: (201) 747-1060

- ㉖ 391 Grand Avenue  
Englewood 07631  
Tel: (201) 567-3933  
TWX: 710-991-9707

## NEW MEXICO

- ㉗ P.O. Box 8366  
Station C 87108  
6501 Lomas Boulevard N.E.  
Albuquerque  
Tel: (505) 255-5586  
TWX: 910-989-1665

- ㉘ 156 Wyatt Drive  
Las Cruces 88001  
Tel: (505) 528-2486  
TWX: 910-983-0550

## NEW YORK

- ㉙ 1219 Campville Road  
Endicott 13760  
Tel: (607) 754-0050  
TWX: 510-252-0890

- ㉚ 238 East 75th Street  
New York 10021  
Tel: (212) 879-2023  
TWX: 710-581-4376

- ㉛ 82 Washington Street  
Poughkeepsie 12601  
Tel: (914) 454-7330  
TWX: 510-248-0012

- ㉜ 39 Saginaw Drive  
Rochester 14623  
Tel: (716) 473-9500  
TWX: 510-253-5981

- ㉝ 1025 Northern Boulevard  
Roslyn, Long Island 11576  
Tel: (516) 859-8400  
TWX: 510-223-0811

- ⑳ 5858 East Molloy Road  
Syracuse 13211  
Tel: (315) 454-2486  
TWX: 710-541-0482

## NORTH CAROLINA

- ㉞ P.O. Box 5187  
1923 North Main Street  
High Point 27282  
Tel: (919) 882-6873  
TWX: 510-926-1516

## OHIO

- ㉟ 5579 Pearl Road  
Cleveland 44129  
Tel: (216) 884-9209  
TWX: 810-421-8500

- ㊱ 1250 West Dorothy Lane  
Dayton 45409  
Tel: (513) 298-0351  
TWX: 810-459-1925

## OREGON

- ㊲ 2737 S.W. Corbett Avenue  
Portland 97201  
Tel: (503) 228-5107

## PENNSYLVANIA

- ㊳ Park Place Office Building  
Camp Hill  
Tel: (717) 737-6791

- ㊴ Monroe Complex  
Moss Side Boulevard  
Monroeville 15146  
Tel: (412) 271-0724  
TWX: 710-797-3650

- ㊵ 144 Elizabeth Street  
West Conshohocken 19428  
Tel: (215) 248-1600, 828-6200  
TWX: 510-660-8715

## TEXAS

- ㊶ P.O. Box 7166  
3505 Inwood Road  
Dallas 75209  
Tel: (214) 357-1881  
TWX: 910-861-4081

- ㊷ P.O. Box 22813  
4242 Richmond Avenue  
Houston 77027  
Tel: (713) 667-2407  
TWX: 910-881-2645

- ㊸ GOVERNMENT CONTRACT OFFICE  
225 Billy Mitchell Road  
San Antonio 78226  
Tel: (512) 434-4171  
TWX: 910-871-1170

## UTAH

- ㊹ 2890 South Main Street  
Salt Lake City 84115  
Tel: (801) 486-8166  
TWX: 910-925-5681

## VIRGINIA

- ㊺ P.O. Box 6514  
2111 Spencer Road  
Richmond 23230  
Tel: (703) 282-5451  
TWX: 710-956-0157

## WASHINGTON

- ㊻ 11656 N.E. Eighth Street  
Bellevue 98004  
Tel: (206) 454-3971  
TWX: 910-443-2303

## FOR AREAS NOT LISTED, CONTACT:

Hewlett-Packard  
1501 Page Mill Road  
Palo Alto, California 94304  
Tel: (415) 326-7000  
TWX: 910-373-1267  
Telex: 34-8461

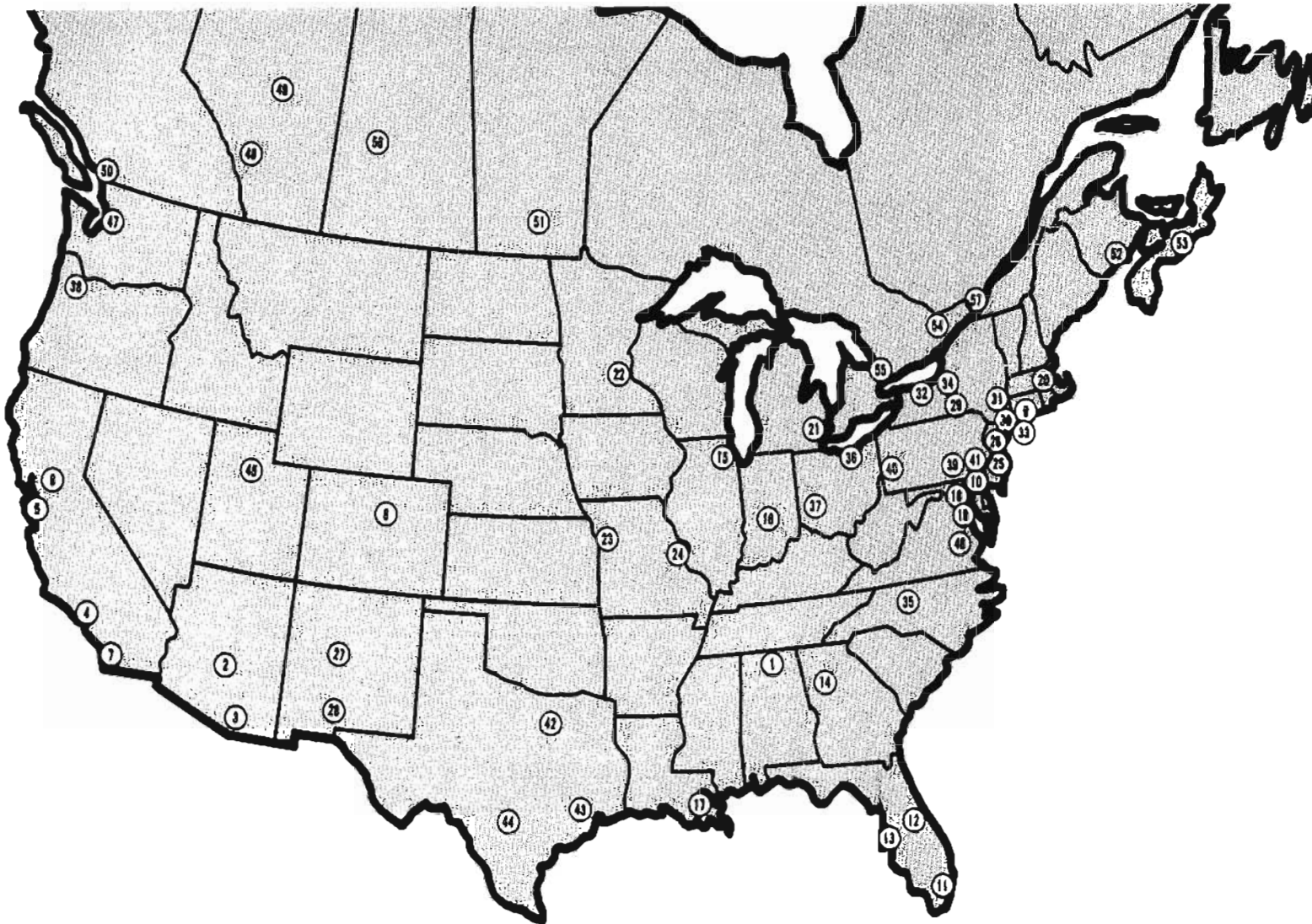
**ALBERTA**

48

X-Ray and Radium Ltd.  
239-10th Avenue, S.E.  
Calgary  
Tel: (403) 266-2718  
Cable: X-RAD Calgary

49

X-Ray and Radium Ltd.  
11011-107th Avenue  
Edmonton  
Tel: (403) 422-8615  
Cable: X-RAD Edmonton

**BRITISH COLUMBIA**

50

Hewlett-Packard (Canada) Ltd.  
2184 West Broadway  
Vancouver  
Tel: (604) 738-7520  
TWX: 610-922-5050

X-Ray and Radium Ltd.  
2283 West Broadway  
Vancouver  
Tel: (604) 731-1543  
Cable: X-RAD Vancouver

**MANITOBA**

51

X-Ray and Radium Ltd.  
58 Westbrook Avenue  
Winnipeg  
Tel: (204) 942-8211  
Cable: X-RAD Winnipeg

**NEW BRUNSWICK**

52

X-Ray and Radium Ltd.  
177 Prince William Street  
Saint John  
Tel: (506) 693-2057  
Cable: X-RAD Saint John

**NOVA SCOTIA**

53

X-Ray and Radium Ltd.  
6100 Young Street  
Halifax  
Tel: (902) 455-4291  
Cable: X-RAD Halifax

**ONTARIO**

54

Hewlett-Packard (Canada) Ltd.  
880 Lady Ellen Place  
Ottawa 3  
Tel: (613) 722-4223  
TWX: 810-562-1952

55

Hewlett-Packard (Canada) Ltd.  
1415 Lawrence Avenue West  
Toronto  
Tel: (416) 249-9198  
TWX: 610-492-2382

X-Ray and Radium Ltd.  
1400 Don Mills Road  
Don Mills  
Tel: (416) 447-5171  
Cable: X-RAD Toronto

**SASKATCHEWAN**

56

X-Ray and Radium Ltd.  
88-24th Street, East  
Saskatoon  
Tel: (306) 242-0529  
Cable: X-RAD Saskatoon

**QUEBEC**

57

Hewlett-Packard (Canada) Ltd.  
275 Hymus Boulevard  
Pointe Claire  
Tel: (514) 697-4232  
TWX: 810-422-3022  
Telex: 01-2819

X-Ray and Radium Ltd.  
2800 Bates Road  
Montreal  
Tel: (514) 739-2408  
Cable: X-RAD Montreal

**FOR AREAS NOT LISTED, CONTACT:**

Hewlett-Packard Inter-Americas  
1501 Page Mill Road  
Palo Alto, California 94304  
Tel: (415) 326-7000  
TWX: 910-373-1267  
Telex: 034-8461  
Cable: HEWPACK Palo Alto



Electronic instrumentation, pages 76-569 in this catalog



Medical instrumentation, pages 42-75 in this catalog



Chemical instrumentation, pages 15-41 in this catalog

## SALES &amp; SERVICE OFFICES



## EUROPE

## AUSTRIA

① Unilabor H.m.b.H.  
Wissenschaftliche Instrumente  
Rummelhardtgasse 6/3  
P.O. Box 33  
Vienna IX/71  
Tel: 426 181  
Cable: LABORINSTRUMENT Vienna

## BELGIUM

② Hewlett-Packard Benelux S.A.  
20-24 rue de l'Hôpital  
Brussels  
Tel: 11 22 20  
Cable: PALOBEN Brussels

## DENMARK

③ Tage Olsen A/S  
Rønnegade 1  
Copenhagen Ø  
Tel: 29 48 00  
Cable: TOCOPEN Copenhagen

A/S N. C. Nielsen  
10 Vestergade  
Copenhagen K  
Tel: Byen 9119  
Cable: NICANI Copenhagen

Bie & Berntsen  
35 Pilestræde  
Copenhagen K  
Tel: MI 6011  
Cable: BIKEMI Copenhagen

## FINLAND

④ INTO O/Y  
Meritulinkatu 11  
P.O. Box 10153  
Helsinki 10  
Tel: 61 133  
Cable: INTO Helsinki

Instrumentarium  
Aleksanterinkatu 15  
P.O. Box 357  
Helsinki 10  
Tel: 1 50 11

## FRANCE

⑤ Hewlett-Packard Franco  
2 rue Tête d'Or  
Lyon, 6 - Rhône  
Tel: 52 35 66

⑥ Hewlett-Packard Franco  
150 Boulevard Massena  
Paris 13e  
Tel: 707 97 19  
Cable: HEWPACK Paris

## GERMANY

⑦ Hewlett-Packard Vertriebs-GmbH  
Lietzenburger Strasse 30  
1 Berlin W 30  
Tel: 24 86 36

⑧ Hewlett-Packard Vertriebs-GmbH  
Herrenberger Strasse 110  
703 Böblingen, Württemberg  
Tel: 6971  
Cable: HEPAG Böblingen

⑧ Hewlett-Packard Vertriebs-GmbH  
Achenbachstrasse 15  
4 Düsseldorf 1  
Tel: 68 52 58

⑩ Hewlett-Packard Vertriebs-GmbH  
Kurfürstenstrasse 95  
6 Frankfurt 50  
Tel: 52 00 36  
Cable: HEWPACKSA Frankfurt

⑪ Hewlett-Packard Vertriebs-GmbH  
Beim Strohhaus 26  
2 Hamburg 1  
Tel: 24 05 52  
Cable: HEWPACKSA Hamburg

⑫ Hewlett-Packard Vertriebs-GmbH  
Reginfriedstrasse 13  
8 Munich 9  
Tel: 49 51 21  
Cable: HEWPACKSA Munich

## GREECE

⑬ Kostos Karayannis  
18, Ermou Street  
Athens 126  
Tel: 230 301  
Cable: RAKAR Athens

Etanem Company  
Amerikis Street 12  
Athens 134  
Tel: 626 972  
Cable: ETANEM Athens

"INTECO" Technical Agencies  
Skoufa 15  
Athens 136  
Tel: 631 072

## ICELAND

⑭ Elding Trading Company Inc.  
Hafnarhvoli - Tryggvogotu  
Reykjavik  
Tel: 1 58 20  
Cable: ELDING Reykjavik

## IRELAND

⑮ Smith & Sheppard (1940) Ltd.  
124 St. Stephen's Green  
Dublin  
Tel: 5 25 00  
Cable: SURGICAL Dublin

Hewlett-Packard Ltd.  
224 Bath Road  
Slough, Bucks, England  
Tel: Slough 28406-9, 29486-9  
Cable: HEWPIE Slough

## ITALY

⑯ Hewlett-Packard Italiana S.p.A.  
Viale Lunigiana 46  
Milan  
Tel: 69 15 84  
Cable: HEWPACKIT Milan

⑰ Hewlett-Packard Italiana S.p.A.  
Palazzo Italia  
Piazza Marconi 25  
Rome - Eur  
Tel: 591 2544  
Cable: HEWPACKIT Rome

## NETHERLANDS

⑱ Hewlett-Packard Benelux, N.V.  
de Boelelaan 1043  
Amsterdam, Z.2  
Tel: 42 77 77  
Cable: PALOBEN Amsterdam

## NORWAY

⑲ Morgenstjerne & Co. A/S  
Ingeniofirma  
6 Wessels Gate  
Oslo  
Tel: 20 16 35  
Cable: MOROF Oslo

Labor-Teknikk  
P.O. Box 1451-Vika  
Wm. Thranesgata 1  
Oslo  
Tel: 60 32 23

## PORTUGAL

⑳ Telecra  
Rua Rodrigo da Fonseca 103  
P.O. Box 2531  
Lisbon 1  
Tel: 68 60 72  
Cable: TELECRA Lisbon

Munditer  
Intercambio Mundial de  
Comercio S.a.r.l.  
Avenida Antonio Augusto  
de Agular 138  
Lisbon  
Tel: 73 21 31  
Cable: INTERCAMBIO Lisbon

Equipamentos de Laboratorio, Lda.  
Rua Pedro Nunes, 47  
Apartado 1.100  
Lisbon 1

Electronic instrumentation,  
pages 76-569 in this catalog

Medical instrumentation,  
pages 42-75 in this catalog

Chemical instrumentation,  
pages 15-41 in this catalog

## SPAIN

㉑ Atajo Ingenieros  
Enrique Larreta 12  
Madrid, 16  
Tel: 235 43 44  
Cable: TELEATAJO Madrid

Atajo Ingenieros  
Urgel, 259  
Barcelona, 11  
Tel: 230 69 88

## SWEDEN

㉒ HP Instrument AB  
Hagakarsgatan 7  
Mölnådal  
Tel: 031 - 27 66 00

㉓ HP Instrument AB  
Centralvägen 28  
Solna  
Tel: 08 - 83 08 30  
Cable: MEASUREMENTS Stockholm

## SWITZERLAND

㉔ HEWPAK AG  
Zürcherstrasse 20  
8952 Schlieren  
Zurich  
Tel: (051) 98 18 21  
Cable: HEWPACKAG Zurich

Instrumenten Gesellschaft AG  
Muhlezaigstrasse 15  
Zurich  
Tel: (051) 54 04 84

## TURKEY

㉕ Telekom Engineering Bureau  
P.O. Box 376 - Galata  
Istanbul  
Tel: 49 40 40  
Cable: TELEMATION Istanbul

Dr. Faruk Komili  
Vall Konagi Caddesi No. 35  
Harbiye, Istanbul  
Tel: 48 18 07  
Cable: PIXTRON Istanbul

## UNITED KINGDOM

㉖ Hewlett-Packard Ltd.  
224 Bath Road  
Slough, Bucks  
Tel: Slough 28406-9, 29486-9  
Cable: HEWPIE Slough

## YUGOSLAVIA

㉗ Belram S.A.  
83 avenue des Mimosas  
Brussels 15, Belgium  
Tel: 35 29 58  
Cable: BELRAMEL Brussels

## FOR AREAS NOT LISTED, CONTACT:

Hewlett-Packard S.A.  
54 Route des Acacias  
Geneva, Switzerland  
Tel: (022) 42 81 50  
Telex: 2.24.88  
Cable: HEWPACKSA Geneva

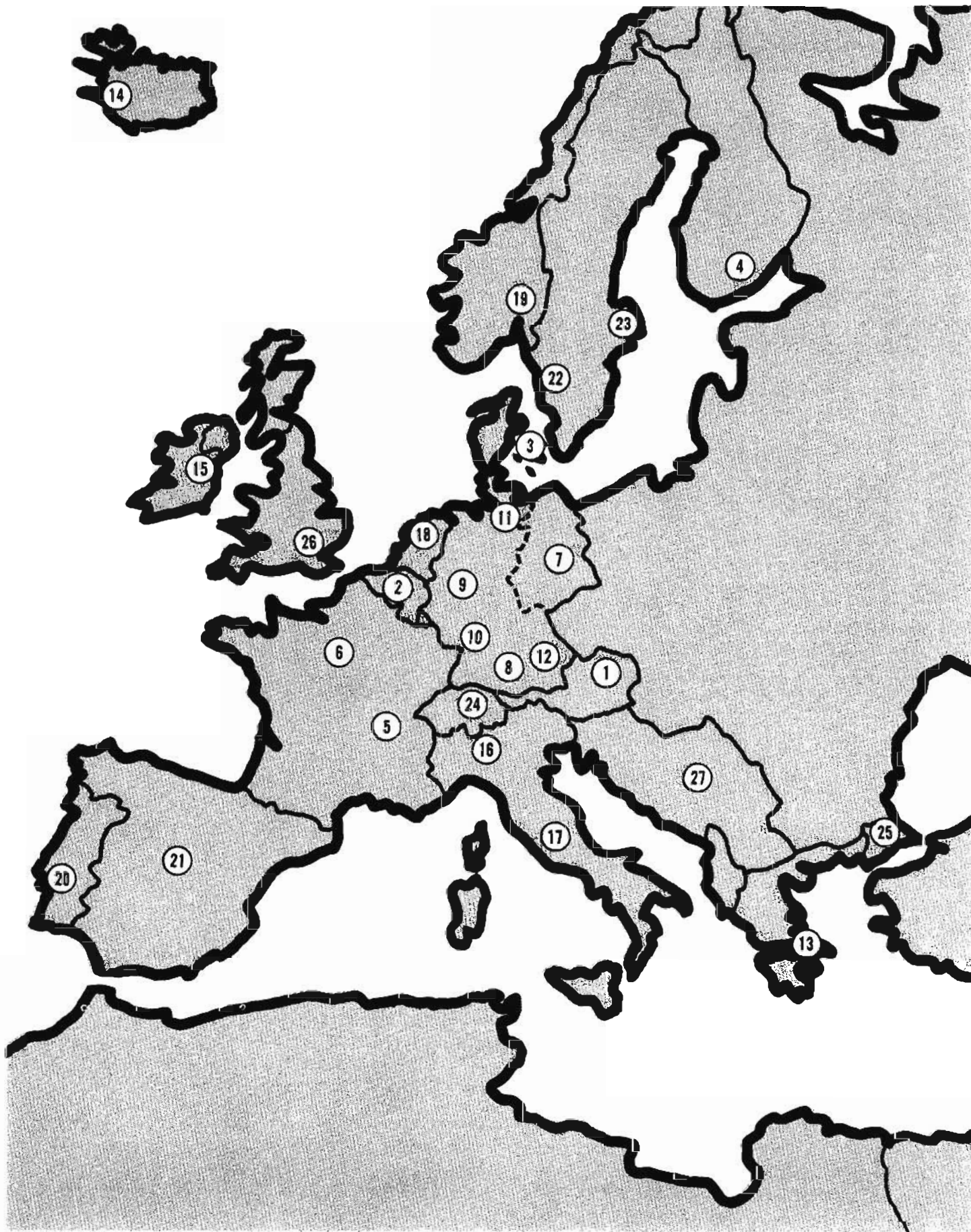



# SALES & SERVICE OFFICES



# AFRICA, ASIA AUSTRALIA

## AUSTRALIA

- ① Watson Victor Ltd.  
228 North Terrace  
Adelaide, South Australia  
Tel: 23-2155
- ② Watson Victor Ltd.  
201 Victoria Parade  
Collingwood, Victoria  
Tel: 419-1588
- ③ Sample Electronics (Vic) Pty., Ltd.  
22-26 Weir Street  
Glen Iris S.E. 6  
Melbourne, Victoria  
Tel: 20-1371 (4 lines)  
Cable: SAMPLE Melbourne
- ④ Watson Victor Ltd.  
Box 117 P. O. Woolongabba  
893 Stanley Street  
East Brisbane, Queensland  
Tel: 91-4441
- ⑤ Sample Electronics  
(N.S.W.) Pty. Ltd.  
4 Grose Street  
Glebe, New South Wales  
Tel: 69-6338  
Cable: SAMPLE Sydney
- ⑥ Watson Victor Ltd.  
Central Service Division  
17 Vincent Street  
Marrickville, N.S.W.  
Tel: 51-3261
- ⑦ Watson Victor Ltd.  
P. O. Box 144, Ryde  
95-99 Epping Road  
North Ryde, New South Wales  
Tel: 88-8188  
Cable: WATSONVICTOR Sydney
- ⑧ Watson Victor Ltd.  
1122 Hay Street  
Perth, Western Australia  
Tel: 21-8021

## ETHIOPIA

- ① African Salespower & Agency  
Private Ltd., Co.  
P. O. Box 718  
Addis Ababa  
Tel: 44090  
Cable: ASACO Addisababa

## INDIA

- ① The Scientific Instrument Co., Ltd.  
6, Tej Bahadur Sapru Road  
Allahabad 1  
Tel: 2451  
Cable: SICO Allahabad
- ② The Scientific Instrument Co., Ltd.  
240, Dr. Dadabhai Naoroji Road  
Bombay 1  
Tel: 26-2642  
Cable: SICO Bombay
- ③ Pioneer Equipment Co., Pvt. Ltd.  
Seksaria Chambers  
139, Nagindas Master Road  
P. O. Box 1909  
Fort, Bombay 1  
Tel: 25-1882  
Cable: PIOMETAL Bombay
- ④ The Scientific Instrument Co., Ltd.  
11, Esplanade East  
Calcutta 1  
Tel: 23-4129  
Cable: SICO Calcutta
- ⑤ Pioneer Equipment Co., Pvt. Ltd.  
3, Esplanade East  
Calcutta 1
- ⑥ The Scientific Instrument Co., Ltd.  
30, Mount Road  
Madras 2  
Tel: 88339  
Cable: SICO Madras
- ⑦ Pioneer Equipment Co., Pvt. Ltd.  
22, Royapettah High Road  
First Floor, North Wing  
Madras 14

⑪

- ⑪ The Scientific Instrument Co., Ltd.  
B-7, Ajmeri Gate Extn.  
New Delhi 1  
Tel: 27-1053  
Cable: SICO New Delhi

## IRAN

⑫

- ⑫ Pioneer Equipment Co., Pvt. Ltd.  
36-B, Nizamuddin West  
New Delhi 13

## ISRAEL

⑬

- ⑬ Telecom. Ltd.  
P. O. Box 1812  
Teheran  
Tel: 43850, 48111  
Cable: BASCOM Teheran
- ⑭ Electronics & Engineering  
Division of Motorola Israel Ltd.  
16, Kremenetski Street  
Tel-Aviv  
Tel: 35021/2/3  
Cable: BASTEL Tel-Aviv

## JAPAN

⑮

- ⑮ Messrs. Manfred Gottesmann  
P. O. Box 1252  
22, Littenblum Street  
Tel-Aviv  
Tel: 56965  
Cable: MAGO Tel-Aviv

⑯

- ⑯ Yokogawa-Hewlett-Packard Ltd.  
Shinhankyu Building  
No. 8, Umeda  
Kita-ku, Osaka City  
Tel: 313-0091

⑰

- ⑰ Yokogawa-Hewlett-Packard Ltd.  
Ito Building  
No. 59, Kotori-cho  
Nakamura-ku, Nagoya City  
Tel: 551-0215

⑱

- ⑱ Yokogawa-Hewlett-Packard Ltd.  
Ohashi Building  
No. 59, 1-chome, Yoyogi  
Shibuya-ku, Tokyo  
Tel: 370-2281  
Cable: YOKOHEWPACK Tokyo

## KENYA

⑲

- ⑲ The Nissho Company Ltd.  
Nissho Building  
10, Nihonbashi-Edobashi, 1-chome  
Chuo-ku, Tokyo  
Tel: 273-5111  
Cable: NISSHOCONY Tokyo

## KOREA

⑳

- ⑲ Heiwa Bussan Co., Ltd.  
18, 2-chome, Marunouchi  
Chiyoda-ku, Tokyo  
Tel: 211-8456  
Cable: KISHMAKER Tokyo

- ⑲ International Aeradio (E.A.), Ltd.  
Nairobi Airport  
P. O. Box 19012  
Nairobi  
Tel: 82222  
Cable: INTAERIO Nairobi

- ⑲ R. J. Tilbury Ltd.  
P. O. Box 2754  
Suite 517/518  
Hotel Ambassadeur  
Nairobi  
Tel: 25670, 26803, 68206  
Cable: ARJAYTEE Nairobi

- ⑲ American Trading Co., Korea, Ltd.  
Seoul P. O. Box 1103  
112-35 Sokong-Dong  
Jung-ku, Seoul  
Tel: 3.7049, 3.7613  
Cable: AMTRACO Seoul

- ⑲ Asla Science & Company  
International P. O. Box 1250  
23-15, 1-KA, Choongmoo-ro  
Choong-ku, Seoul  
Tel: 28-1431  
Cable: ASIASCIENT Seoul

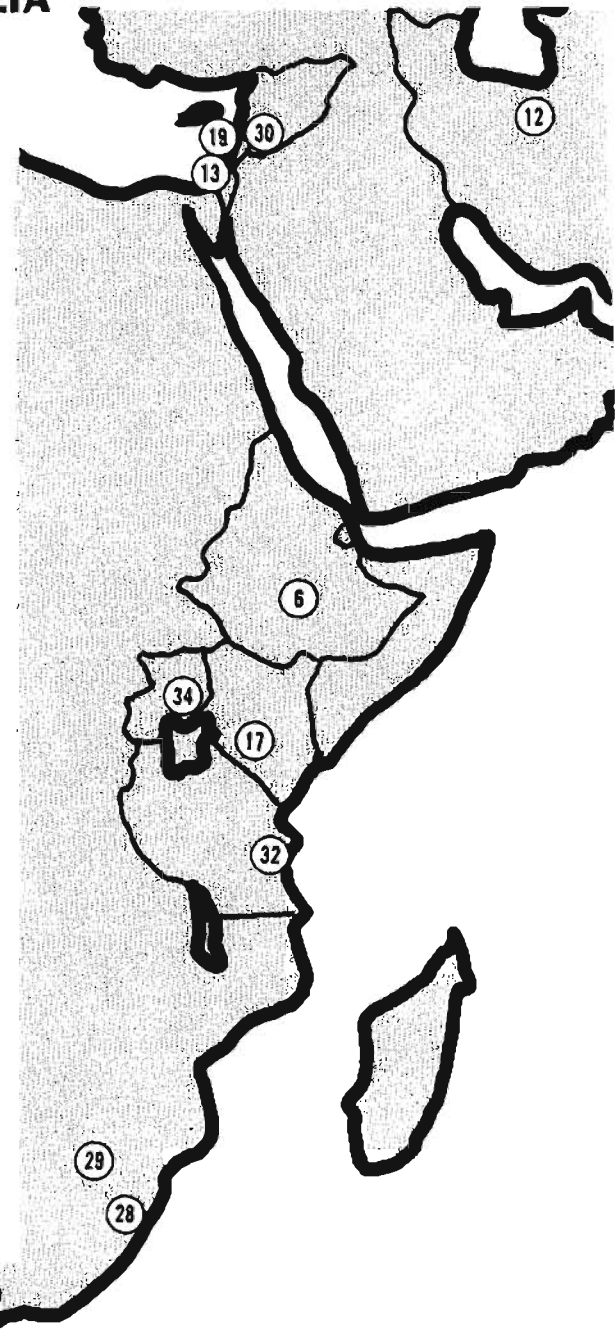

## LEBANON

⑲

- ⑲ Constantin E. Macridis  
Clemenceau Street  
Clemenceau Center  
Beirut  
Tel: 220846  
Cable: ELECTRONUCLEAR Beirut

## MALAYSIA

⑳

- ⑲ F. Makhlouf & Co.  
144, Damascus Avenue  
Beirut  
Tel: 26221, 42662  
Cable: MAKHLOUFCO Beirut
- ⑲ Mechanical & Combustion  
Engineering Co., Ltd.  
P. O. Box No. 24  
No. 6, Road 69D  
Petaling Jaya, Selangor  
Kuala Lumpur  
Cable: MECOMB Kuala Lumpur

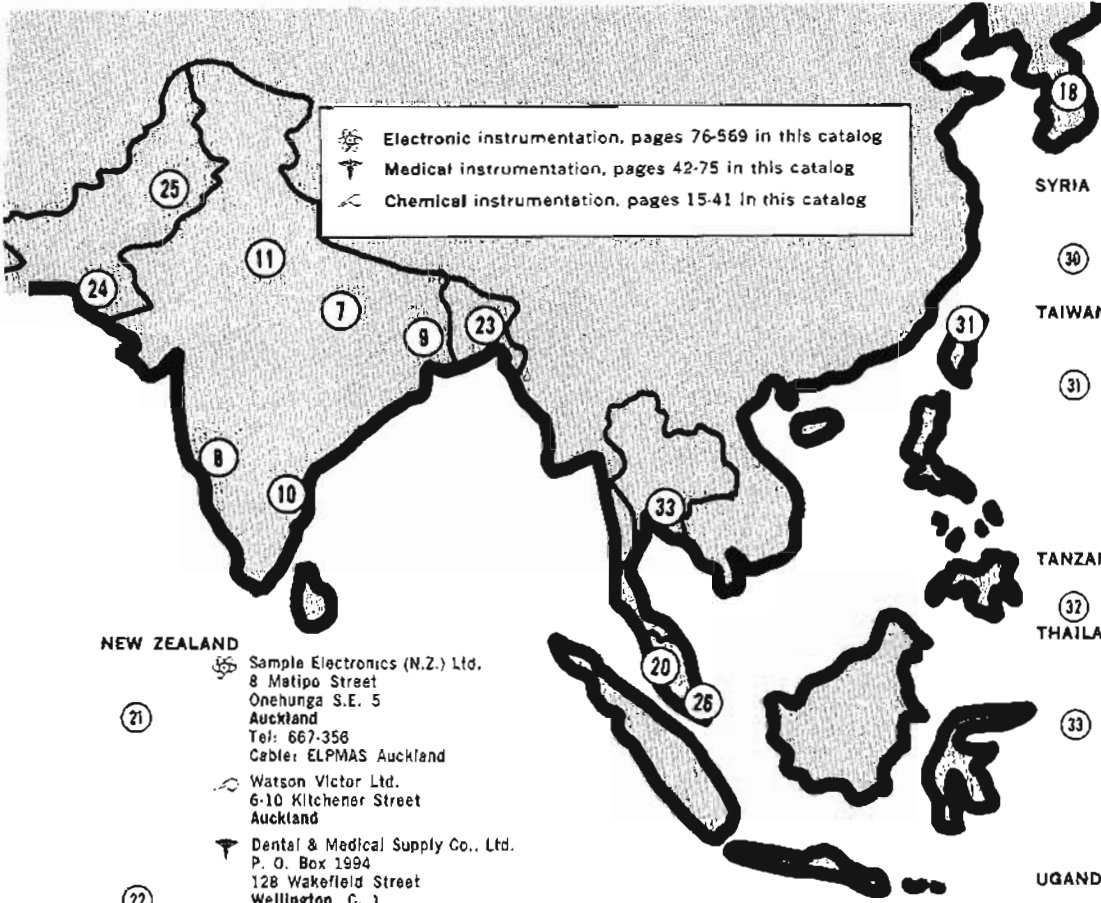

**NEW ZEALAND**

- 21 Sampla Electronics (N.Z.) Ltd.  
8 Matipo Street  
Onehunga S.E. 5  
Auckland  
Tel: 667-358  
Cable: ELPMAS Auckland
- 22 Watson Victor Ltd.  
6-10 Kilchener Street  
Auckland
- 22 Dental & Medical Supply Co., Ltd.  
P. O. Box 1994  
128 Wakefield Street  
Wellington, C. 1  
Tel: 70-789  
Cable: DENTAL Wellington
- 22 Watson Victor Ltd.  
P. O. Box 1180  
16 The Terrace  
Wellington  
Cable: WATVIC Wellington

**PAKISTAN (EAST)**

- 23 Mushko & Company, Ltd.  
Zinat Chambers  
31, Jinnah Avenue  
Dacca  
Tel: 80058  
Cable: COOPERATOR Dacca
- 23 Dodhys Agencies  
9-H, Motijheel  
Dacca 2,  
Cable: DODHYS Dacca

**PAKISTAN (WEST)**

- 24 Mushko & Company, Ltd.  
Oosman Chambers  
Victoria Road  
Karachi 3  
Tel: 51027, 52927  
Cable: COOPERATOR Karachi
- 28 Dodhys Agencies  
2, McLeod Road  
Lahore 8  
Tel: 66180  
Cable: DODHYS Lahore

**SINGAPORE**

- 28 Mechanical & Combustion  
Engineering Company, Ltd.  
Alexandra P. O. Box No. 46  
9, Jalan Kilang  
Redhill Industrial Estate  
Singapore 3  
Tel: 642361-3  
Cable: MECOMB Singapore

**SOUTH AFRICA**

- 27 F. H. Flanter & Co. (Pty.), Ltd.  
Rosella House  
Buitencingle Street  
Cape Town  
Tel: 3-3817  
Cable: AUTOPHONE Cape Town

**SYRIA**

- 18 F. H. Flanter & Co. (Pty.), Ltd.  
104 Pharmacy House  
80 Jorissen Street  
Braamfontein, Johannesburg  
Tel: 724-4172

**TAIWAN**

- 30 Sawah & Co.  
Place Azmé  
B. P. 2308  
Damascus  
Tel: 16387, 19697, 14268  
Cable: SAWAH Damascus
- 31 Hwa Sheng Electronic Co., Ltd.  
P. O. Box 1558  
21 Nanking West Road  
Taipei  
Tel: 46076, 45936  
Cable: VICTRONIX Taipei
- 31 Hammer Trading Company Ltd.  
P. O. Box 914  
74, Kai Feng Street, First Section  
Taipei  
Tel: 24842  
Cable: HAMMERC0 Taipei

**TANZANIA**

- 32 International Aeradio (E.A.), Ltd.  
P. O. Box 861  
Dar-es-salaam

**THAILAND**

- 33 The International  
Engineering Co., Ltd.  
P. O. Box 39  
614 Sukhumvit Road  
Bangkok  
Tel: 913460-1-2  
Cable: GYSOM Bangkok
- 33 Chalermmas  
39 Prapithuk Road  
Bangkok  
Tel: 27508  
Cable: CHALERMMS Bangkok

**UGANDA**

- 34 International Aeradio (E.A.), Ltd.  
P. O. Box 2577  
Kampala  
Cable: INTAERIO Kampala

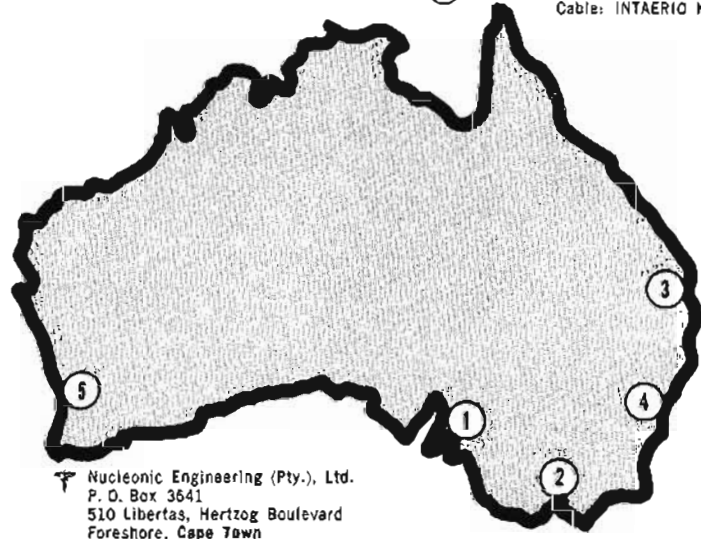

- 1 Nucleonic Engineering (Pty.), Ltd.  
P. O. Box 3641  
510 Libertas, Hertzog Boulevard  
Foreshore, Cape Town  
Tel: 37769  
Cable: NUCLEAR Cape Town
- 2 Nucleonic Engineering (Pty.), Ltd.  
P. O. Box 2143  
82, Syfret House  
36, Gardiner Street  
Durban, Natal  
Tel: 20272
- 3 Nucleonic Engineering (Pty.), Ltd.  
P. O. Box 1257, Braamfontein  
Total Centre, 9th Floor  
Corner Jorissen and Bertha Streets  
Johannesburg  
Tel: 724-9341/2/3  
Cable: NUCLEAR Johannesburg

**FOR AREAS NOT LISTED, CONTACT:**

Hewlett-Packard Export Marketing  
1501 Page Mill Road  
Palo Alto, California 94304  
Tel: (415) 326-7000  
Telex: 034-8461  
Cable: HEWPACK Palo Alto

